

DC VOLUME, TONE CONTROL CIRCUIT

The KA2107 is a monolithic integrated circuit designed for 2 channel volume and tone control.

FUNCTIONS

- DC Volume Control
- DC Tone Control (Bass & Treble)
- Balance Control (R, L-Ch)

FEATURES

- Easier compact set design
- All function enable DC controllable

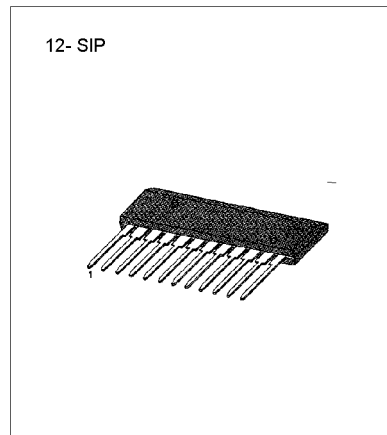

BLOCK DIAGRAM

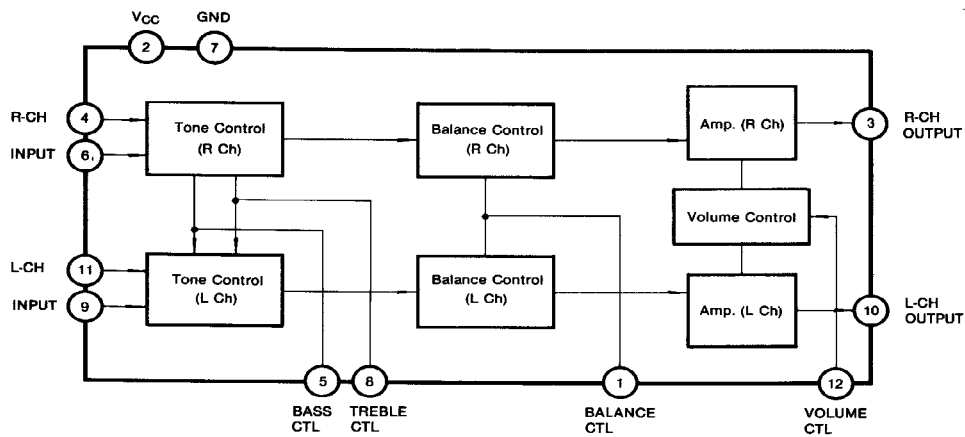

Fig. 1

ORDERING INFORMATION

Device	Package	Operating Temperature
KA2107	12-SIP	-20°C ~ +70°C

ABSOLUTE MAXIMUM RATINGS (T_A =25 °C)

Characteristic		Symbol	Value		Unit
Voltage	Supply Voltage	V _{CC}	14.4		V
	Circuit Voltage	V _{1,4,5,6,7} V _{8,9,11,12,7}	0	V _{2,7}	V
Current	Supply Current	I ₂	64		mA
	Circuit Current	I _{3,10}	-40	—	mA
Power Dissipation		P _D	920		mW
Temperature	Operating Temperature	T _{OPR}	-20~+70		°C
	Storage Temperature	T _{STG}	-55~+150		°C

ELECTRICAL CHARACTERISTICS (V_{CC} =12V, T_A =25 °C)

Characteristic	Symbol	Condition	Min	Typ	Max	Unit	Test Circuit
Supply Current	I _{TOT}	V _{CC} =12V	24	38	50	mA	1
Supply Voltage	V _{3, 10-7}	No input, V ₁₂ =V _{CC} , V ₁ =V ₅ =V ₈ =V _{CC} /2	8.0	8.4	8.8	V	2
Volume	Max Output Voltage	V _{OMAX} f=1KHz, V _i =400mV _{rms}	190	230	270	μV _{rms}	2
	Channel Balance	CB V ₁₂ =V _{CC} , V ₁ =V ₅ =V ₈ =V _{CC} /2	—	+0.2	±1.0	dB	2
	Output Starting Voltage	V _(ST) f=1KHz, V _i =400mV _{rms} V ₁₂ =VR, V ₁ =V ₅ =V ₈ =V _{CC} /2	0.40	0.65	0.90	V	2
	Residual Noise Level	V _{MIN} f=1KHz, V _i =400mV _{rms} V ₁₂ =0V, V ₁ =V ₅ =V ₈ =V _{CC} /2	—	25	50	μV _{rms}	2
Balance	Attenuation (R-Ch)	ATT _R f=1KHz, V _i =400mV _{rms} , V ₁₂ =V _{CC} , V ₅ =V ₈ =V _{CC} /2, V _{OR} :V ₁ =(5.5/12) · V _{CC} (at VR · 1), V _{OR2} :V ₁ =0V	-32	-45	—	dB	2
	Attenuation (L-Ch)	ATT _L f=1KHz, V _i =400mV _{rms} , V ₁₂ =V _{CC} , V ₅ =V ₈ =V _{CC} /2, V _{OL1} :V ₁ :(6.5/12) · V _{CC} (at VR · 1), V _{OL2} :V ₁ =V _{CC}	-32	-45	—	dB	2
Tone	Low Frequency Boost Control	V ₄₀ /V _{1K} V _{1K} : Output Voltage at f=1KHz, V _i =400mV _{rms} V ₁₂ =V _{CC} , V ₁ =V ₅ =V ₈ =V _{CC} /2 V ₄₀ : Output Voltage at f=40Hz, V _i =40mV _{rms} V ₁₂ =V _{CC} , V ₅ =V ₈ =V _{CC}	8	10	12	dB	2
	Low Frequency Cut Control	V ₄₀ /V _{1K} V _{1K} : Output Voltage at f=1KHz, V _i =400mV _{rms} V ₁₂ =V _{CC} , V ₁ =V ₅ =V ₈ =V _{CC} /2 V ₄₀ : Output Voltage at f=40Hz, V _i =40mV _{rms} V ₁₂ =V _{CC} , V ₅ =V ₈ =0V	-7.5	-12	-16	dB	2
	High Frequency Boost Control	V _{15K} /V _{1K} V _{1K} : Output Voltage at f=1KHz, V _i =400mV _{rms} V ₁₂ =V _{CC} , V ₁ =V ₅ =V ₈ =V _{CC} /2 V _{15K} : Output Voltage at f=15KHz, V _i =40mV _{rms} V ₁₂ =V _{CC} , V ₅ =V ₈ =V _{CC}	7.5	10	13	dB	2
	High Frequency Cut Control	V _{15K} /V _{1K} V _{1K} : Output Voltage at f=1KHz, V _i =400mV _{rms} V ₁₂ =V _{CC} , V ₁ =V ₅ =V ₈ =V _{CC} /2 V _{15K} : Output Voltage at f=40Hz, V _i =40mV _{rms} V ₁₂ =V _{CC} , V ₅ =V ₈ =0V	-7.5	-12	-18	dB	2

ELECTRICAL CHARACTERISTICS (Continued)

Characteristic	Symbol	Condition	Min	Typ	Max	Unit	Test Circuit
Cross Talk	CT	$f = 1\text{KHz}$, $V_1 = 400\text{mV}_{\text{RMS}}$ $V_{12} = V_{\text{CC}}$, $V_1 = V_5 = V_8 = V_{\text{CC}}/2$	-65	-80	—	dB	2
Output Noise Voltage	V_{NO}	No input, $V_{12} = V_{\text{CC}}$, $V_1 = V_5 = V_8 = V_{\text{CC}}/2$	—	80	120	μV_{RMS}	2
Total Harmonic Distortion	THD	$f = 1\text{KHz}$, $V_1 = 400\text{mV}_{\text{RMS}}$ $V_{12} = V_{\text{CC}}$, $V_1 = V_5 = V_8 = V_{\text{CC}}/2$	—	0.2	0.5	%	2
Input Resistance	$R_{\text{I}(6),(9)}$	$f = 1\text{KHz}$	8.2	11.0	13.5	k Ω	
	$R_{\text{I}(4),(11)}$		11.0	16.0	22.0	k Ω	
Output Resistance	$R_{\text{O}(3),(10)}$	$f = 1\text{KHz}$	60	110	160	Ω	

TEST CIRCUIT

Test Circuit 1 (I_{in})

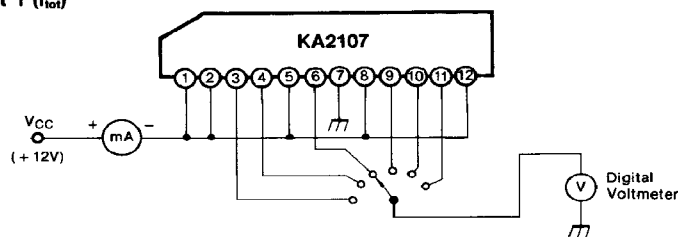

Test Circuit 2 (V_3 , 10-7, V_{OMAX} , CB, V_{ST} , V_{MIN} , ATTR , ATT_L , V_{40}/V_{1K} , V_{15K}/V_{1K} , CT, V_{NO} , THD)

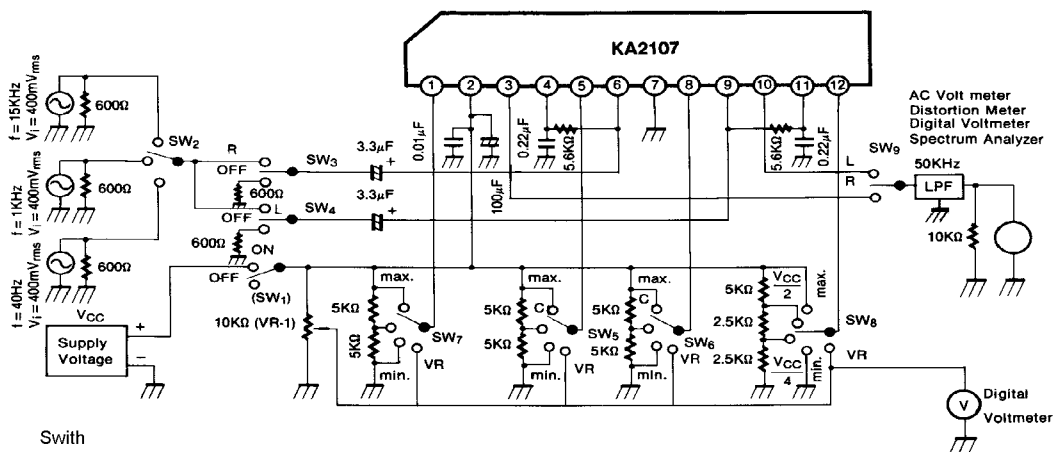

- Switth
- (SW₁) ... Supply Voltage
 - (SW₂) ... Input Signal
 - (SW₃) ... R Side Input
 - (SW₄) ... L Side Input
 - (SW₅) ... Bass Control
 - (SW₆) ... Treble Control
 - (SW₇) ... Treble Control
 - (SW₈) ... Treble Control
 - (SW₉) ... Treble Control

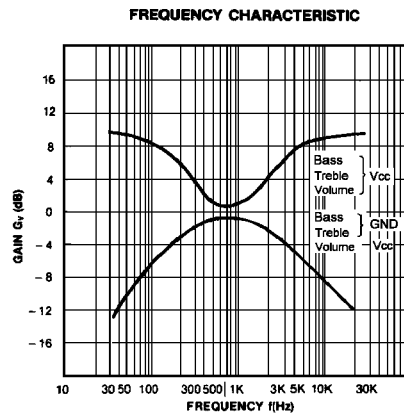
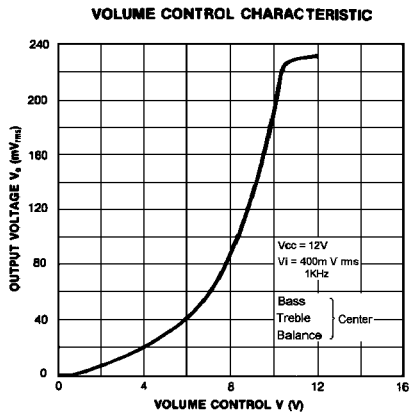

Note: 0dB is Output Voltage at $f_{in} = 1KHz, 400mV_{rms}$
Bass, Treble Control: $V_{cc}/2$
Volume: V_{cc}

TYPICAL APPLICATION CIRCUIT

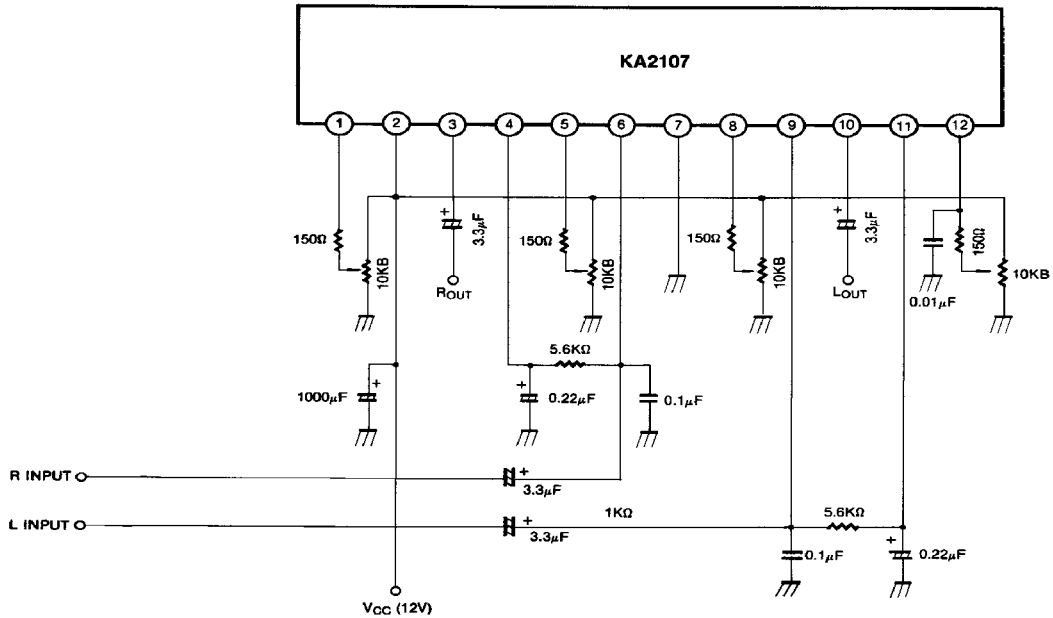

Fig.3