

The KA2206B is a monolithic integrated circuit consisting of a 2-channel power amplifier. It is suitable for stereo and bridge amplifier application of radio cassette tape recorders.

**FEATURES**

- High output power  
Stereo :  $P_O = 2.3W$  (Typ) at  $V_{CC} = 9V, R_L = 4\Omega$ .  
Bridge :  $P_O = 4.7W$  (Typ) at  $V_{CC} = 9V, R_L = 8\Omega$ .
- Low switching distortion at high frequency.
- Small shock noise at the time of power on/off due to a built-in muting circuit
- Good ripple rejection due to a built-in ripple filter.
- Good channel separation.
- Soft tone at the time of output saturation.
- Closed loop voltage gain fixed 45dB (Bridge : 51dB) but availability with external resistor added.
- Minimum number of external parts required.
- Easy to design radiator fin.

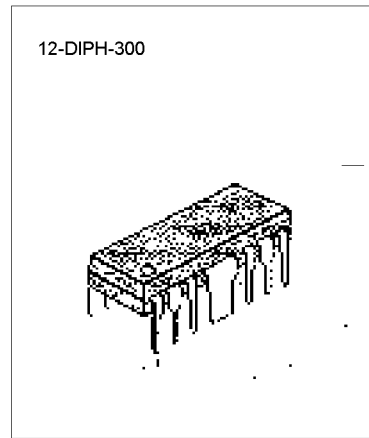

**ORDERING INFORMATION**

Device	Package	Operating Temperature
KS2206B	12-DIPH-300	-20°C ~ +70°C
KS22069BN	16-DIP-300A	

**BLOCK DIAGRAM**

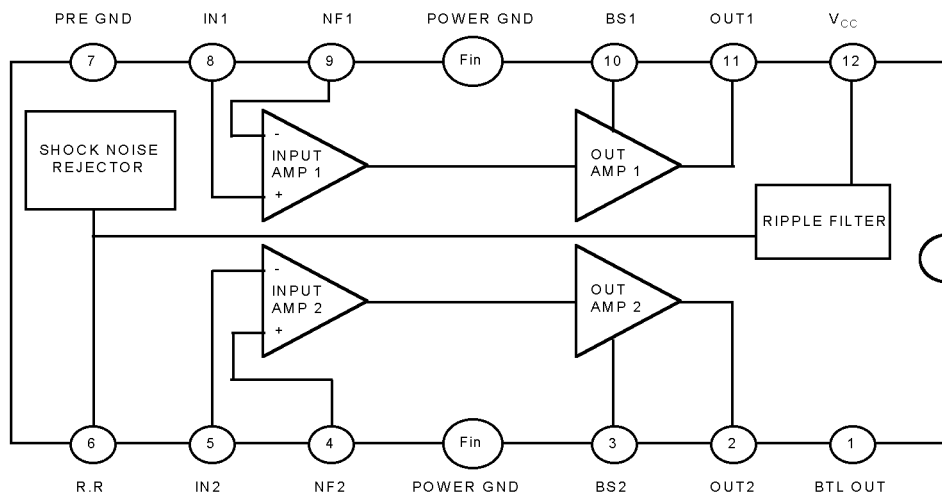

Fig. 1

**ABSOLUTE MAXIMUM RATINGS (Ta = 25°C)**

Characteristics	Symbol	Value	Unit
Supply Voltage	V <sub>CC</sub>	15	V
Power Dissipation	P <sub>D</sub>	4*	W
Operating Temperature	T <sub>OPR</sub>	-20 ~ +70	°C
Storage Temperature	T <sub>STG</sub>	-40 ~ +150	°C

\* Fin is soldering on the PCB

**ELECTRICAL CHARACTERISTICS**

(Ta = 25°C, V<sub>CC</sub> = 9V, f = 1KHz R<sub>G</sub> = 600Ω, unless otherwise specified)

Characteristics	Symbol	Test Condition	Min	Typ	Max	Unit	
Operating Supply Voltage	V <sub>CC</sub>			9	11	V	
Quiescent Circuit Current	I <sub>CCQ</sub>	V <sub>i</sub> = 0, Stereo		40	55	mA	
Closed Loop Voltage Gain	GVC	Stereo	V <sub>i</sub> = -45dBm	43	45	47	dB
		Bridge		49	51	53	
Channel Balance	CB	Stereo	-1	0	+1	dB	
Output Power	P <sub>O</sub>	Stereo	R <sub>L</sub> = 4Ω, THD = 10%,	1.7	2.3		W
			R <sub>L</sub> = 8Ω, THD = 10%,		1.3		W
		Bridge	R <sub>L</sub> = 8Ω, THD = 10%,		4.7		W
Total Harmonic Distortion	THD	Stereo	R <sub>O</sub> = 250mW, R <sub>L</sub> = 4Ω		0.3	1.5	%
		Bridge			0.5		%
Input Resistance	R <sub>I</sub>		21	30		KΩ	
Ripple Rejection Ratio	RR	Stereo, R <sub>G</sub> = 0Ω, V <sub>i</sub> = 150mW f = 100Hz	40	46		dB	
Output Noise Voltage	V <sub>NO</sub>	Stereo, R <sub>G</sub> = 0Ω		0.3	1.0	mW	
		Stereo, R <sub>G</sub> = 10KΩ		0.5	2.0	mV	
Cross Talk	CT	Stereo, R <sub>G</sub> = 10KΩ, V <sub>O</sub> = 0dBm	40	55		dB	

**APPLICATION INFORMATION**

**1. Stereo application**

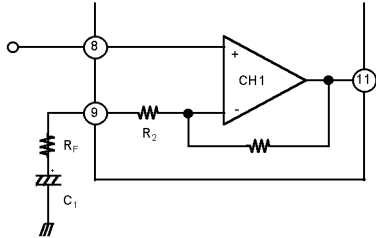

i) Fixed voltage gain  
(Pin 9 connected to GND directly)

$$G_V = 20 \log \frac{R_1}{R_2} \text{ (dB)}$$

ii) Variable voltage gain  
(Rf and C1 connected with pin 9)

$$G_V = 20 \log \frac{R_1}{R_2 + R_F} \text{ (dB)}$$

**2. Bridge application**

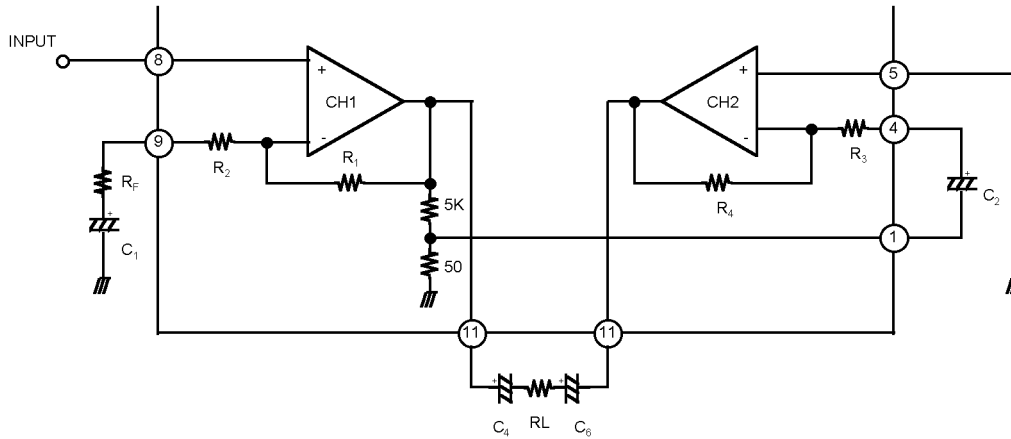

i) Fixed voltage gain (Pin 9 connected to GND directly)

$$G_V = 20 \log \frac{R_1}{R_2} + 6 \text{ (dB)}$$

ii) Variable voltage gain Rf and C1 connected with pin 9)

$$G_V = 20 \log \frac{R_1}{R_2 + R_F} + 6 \text{ (dB)}$$

APPLICATION CIRCUIT

1. Stereo Amplifier

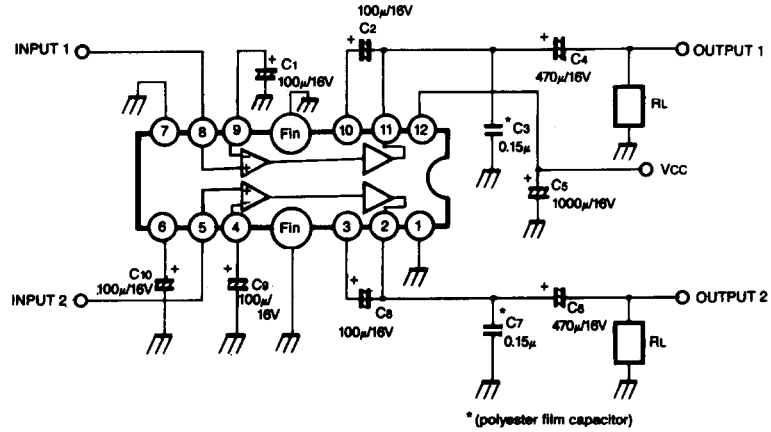

Fig. 2

2. Bridge Amplifier

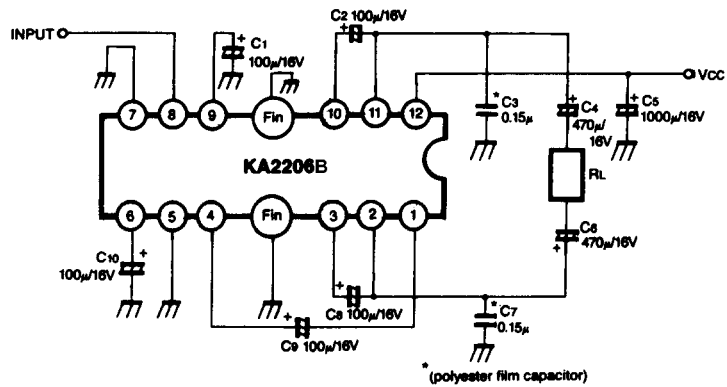

Fig. 3