

## INTRODUCTION

The S1A2245X01 is a monolithic integrated circuit consisting of an FM IF amplifier and detector. It is suitable for car radios.

## FUNCTIONS

- 3-stage IF amplifier
- Peak detector

## FEATURES

- Suitable for FM car radios
- Wide operating supply voltage range:  $V_{CC} = 8V - 14V$
- High detector output voltage ( $V_O = 500mV$ , Typ)
- Excellent AM rejection:  $AMR = 50dB$  (Typ)
- High sensitivity:  $V_{I(LIM)} = 50dB\mu V$  (Typ)
- Simplified single coil tuning
- Low distortion (THD = 0.1 %: Typ)
- Minimum number of external parts required

## ORDERING INFORMATION

Device	Package	Operating Temperature
S1A2245X01-I0U0	7-SIP	-20°C - +70°C

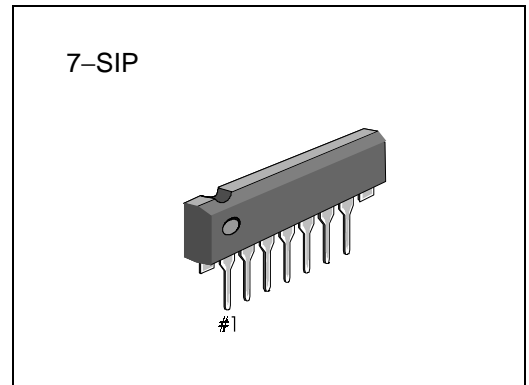

## BLOCK DIAGRAM

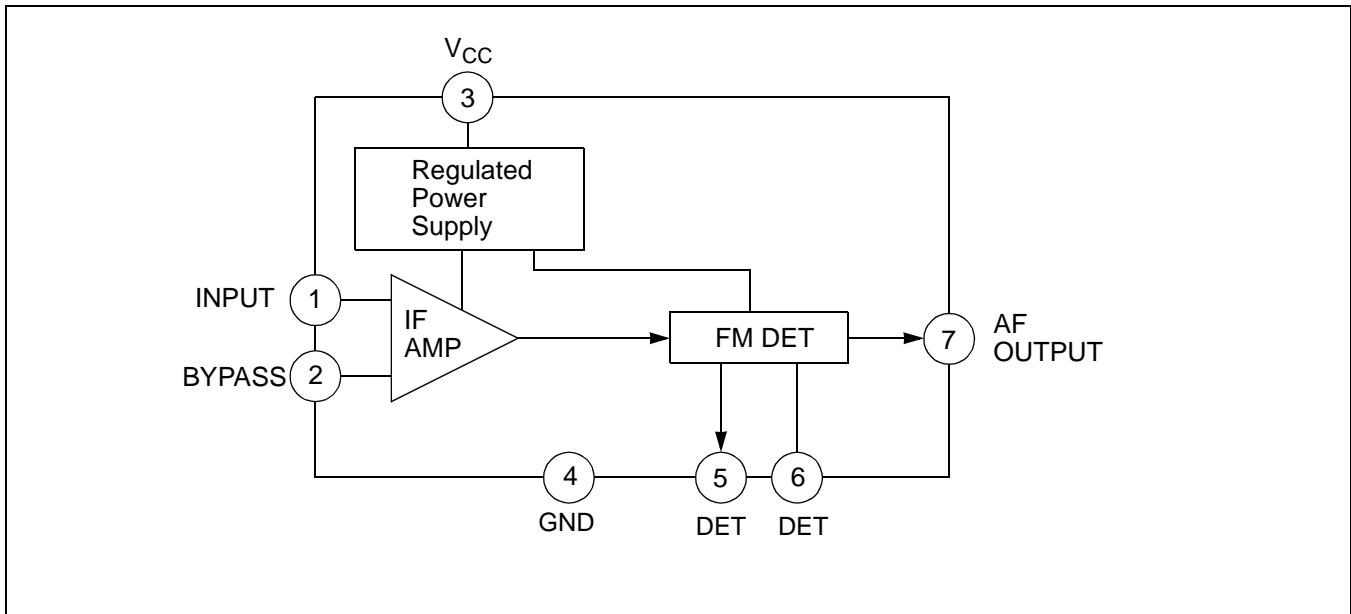

## ABSOLUTE MAXIMUM RATINGS (Ta = 25°C)

Characteristic	Symbol	Value	Unit
Supply Voltage	$V_{CC}$	15	V
Input Voltage	$V_I$	0.7	V
Power Dissipation	$P_D$	400	mW
Operating Temperature	$T_{OPR}$	-20 – +70	°C
Storage Temperature	$T_{STG}$	-40 – +125	°C

**NOTE:** Derated above Ta = 25°C in the proportion of 4 mW/°C

**ELECTRICAL CHARACTERISTICS**

(Ta = 25°C, V<sub>CC</sub> = 12V, f = 10.7MHz, fm = 400Hz)

Characteristic	Symbol	Test Conditions	Min.	Typ.	Max.	Unit
Quiescent Circuit Current	I <sub>CCQ</sub>	V <sub>I</sub> = 0	8	12	15	mA
- 3dB Limiting Sensitivity	V <sub>I(LIM)</sub>	-3dB point from V <sub>O</sub> , V <sub>I</sub> = 80dBμ, Δf = 75kHz	-	50	55	dB
AM Rejection Ratio	AMR	FM: Δf = ± 75kHz dev AM: 30 % Mod V <sub>I</sub> = 80dBμ	-	50	-	dB
Detector Output Voltage	V <sub>O</sub>	Δf = ± 75kHz dev V <sub>I</sub> = 80dBμV	300	500	700	mV
Total Harmonic Distortion	THD	Δf = ± 225kHz dev V <sub>I</sub> = 80dBμV	-	0.2	-	%
Signal to Noise Ratio	S/N	Δf = ± 75kHz dev V <sub>I</sub> = 80dBμV	-	60	-	dB

**TEST CIRCUIT**

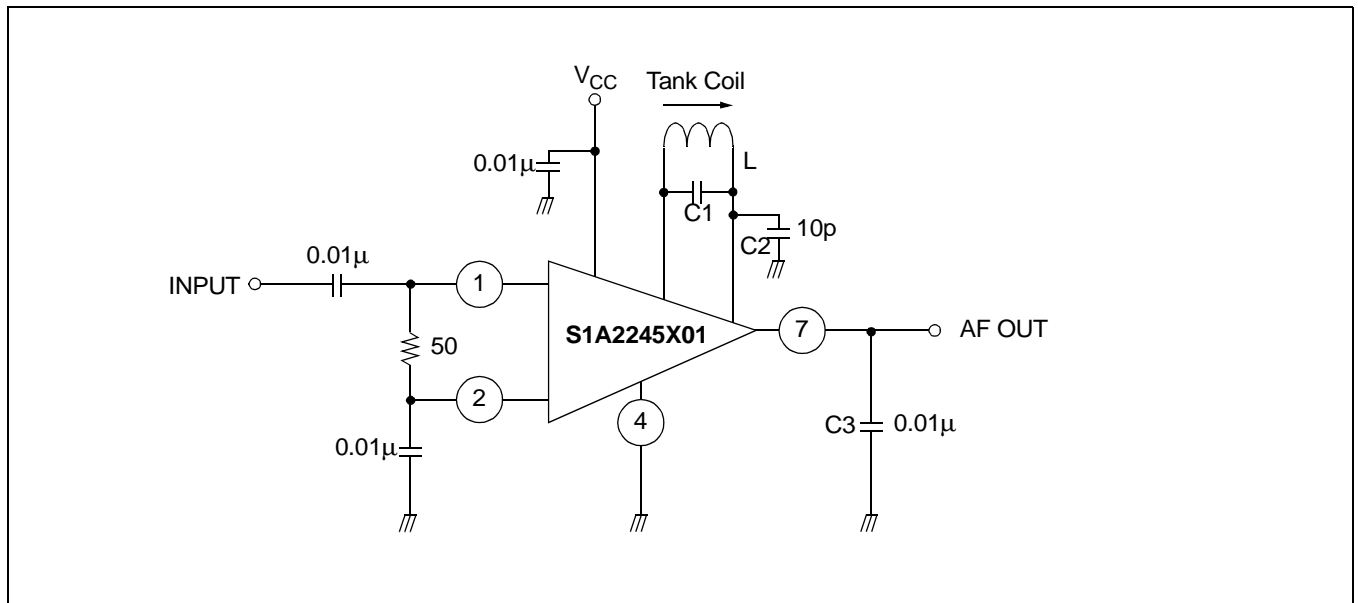

APPLICATION CIRCUIT

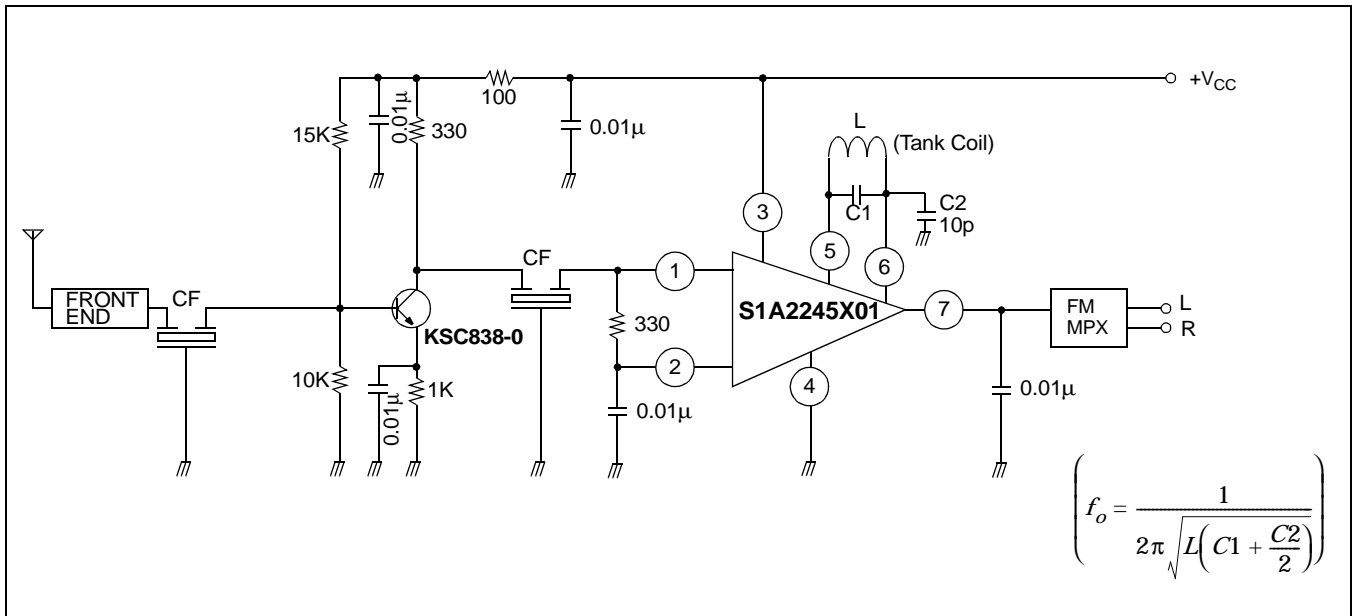

COIL SPECIFICATIONS

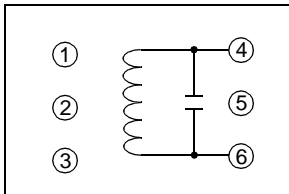

Co(pF)	f(MHz)	Qo(%)	Turns		
			4-6	-	-
27	10.7	150	18	-	-