

EM2420**2.4 GHz IEEE 802.15.4 / ZigBee RF Transceiver****Applications**

- 2.4 GHz IEEE 802.15.4 systems
- ZigBee systems
- Consumer Electronics
- Industrial Control
- Home/building automation
- PC peripherals

Product Description

The **EM2420** is a true single-chip 2.4 GHz IEEE 802.15.4 compliant RF transceiver designed for low-power and low-voltage wireless applications. The **EM2420** includes a digital direct sequence spread spectrum baseband modem and an effective data rate of 250 kbps. The **EM2420** chip is only available from Ember with a licensed Ember networking stack and is targeted to approved 8-bit processors.

The **EM2420** is a low-cost, highly integrated solution for robust wireless communication in the 2.4 GHz unlicensed ISM band. It complies with world-wide regulations covered by EN 300 440 (Europe), CFR47 Part 15 (US) and ARIB STD-T-66 (Japan).

The **EM2420** provides extensive hardware support for packet handling, data buffering, burst transmissions, data encryption, data authentication, clear channel assessment, link quality indication and packet timing information. These

features reduce the load on the host controller and allow the **EM2420** to interface low-cost microcontrollers.

The configuration interface and transmit / receive FIFOs of the **EM2420** are accessed via a SPI interface. In a typical application, the **EM2420** will be used together with a microcontroller and a few external passive components.

The **EM2420** is manufactured to a 0.18 μm CMOS process.

**Key Features**

- True single-chip 2.4 GHz IEEE 802.15.4 compliant RF transceiver with baseband modem, MAC support, and networking stack.
- DSSS baseband modem with 2 MChips/s and 250 kbps effective data rate.
- Suitable for both RFD and FFD operation
- Low current consumption (RX: 19.7 mA, TX: 17.4 mA)
- Low supply voltage (2.1 – 3.6 V) with integrated voltage regulator
- Low supply voltage (1.6 – 2.0 V) with external voltage regulator
- Programmable output power
- No external RF switch / filter needed
- I/Q low-IF receiver
- I/Q direct upconversion transmitter
- Very few external components
- 128 (RX) + 128 (TX) byte data buffering
- Digital RSSI / LQI support
- Hardware MAC encryption (AES-128)
- Battery monitor
- QLP-48 package, 7x7 mm
- Complies with EN 300 440 and FCC CFR-47 part 15, ARIB STD-T-66
- Powerful and flexible development tools available

This document contains information on a preproduction product. Specifications and information herein are subject to change without notice.

Table of contents

Abbreviations	5
References	6
Features	7
Absolute Maximum Ratings	8
Electrical Specifications	9
Pin Assignment	14
Circuit Description	16
Application Circuit	18
Input / output matching	18
Bias resistor	18
Crystal	18
Voltage regulator	18
Power supply decoupling and filtering	18
IEEE 802.15.4 Modulation Format	22
Configuration Overview	23
Evaluation Software	24
4-wire Serial Configuration and Data Interface	25
Register access	25
Status byte	26
Command strobos	27
RAM access	27
FIFO access	29
Multiple SPI access	29
Microcontroller Interface and Pin Description	30
Configuration interface	30
Receive mode	31
RXFIFO overflow	31
Transmit mode	32
General control and status pins	32
Demodulator, Symbol Synchronizer and Data Decision	33
Frame Format	33
Synchronization header	34
Length field	35
MAC protocol data unit	35
Frame check sequence	35
RF Data Buffering	37
Buffered transmit mode	37
Buffered receive mode	38
Unbuffered, serial mode	38
Address Recognition	39
Acknowledge Frames	40
Radio control state machine	42
MAC Security Operations (Encryption and Authentication)	44
Keys	44

Nonce / counter _____	44
Stand-alone encryption _____	45
In-line security operations _____	45
CTR mode encryption / decryption _____	46
CBC-MAC _____	46
CCM _____	46
Timing _____	47
Linear IF and AGC Settings _____	48
RSSI / Energy Detection _____	48
Link Quality Indication _____	49
Clear Channel Assessment _____	50
Frequency and Channel Programming _____	51
VCO and PLL Self-Calibration _____	51
VCO _____	51
PLL self-calibration _____	51
Output Power Programming _____	52
Voltage Regulator _____	53
Battery Monitor _____	53
Crystal Oscillator _____	55
Input / Output Matching _____	56
Transmitter Test Modes _____	56
Unmodulated carrier _____	56
Modulated spectrum _____	57
System Considerations and Guidelines _____	59
Frequency hopping and multi-channel systems _____	59
Data burst transmissions _____	59
Crystal accuracy and drift _____	59
Communication robustness _____	59
Communication security _____	59
Low cost systems _____	60
Battery operated systems _____	60
BER / PER measurements _____	60
PCB Layout Recommendations _____	61
Antenna Considerations _____	61
Configuration Registers _____	63
Test Output Signals _____	84
Package Description (QLP 48) _____	86
Package thermal properties _____	86
Soldering information _____	87
Plastic tube specification _____	87
Carrier tape and reel specification _____	87
Ordering Information _____	88
General Information _____	89

Abbreviations

ADC	-	Analog to Digital Converter
AES	-	Advanced Encryption Standard
AGC	-	Automatic Gain Control
ARIB	-	Association of Radio Industries and Businesses
BER	-	Bit Error Rate
CBC-MAC	-	Cipher Block Chaining Message Authentication Code
CCA	-	Clear Channel Assessment
CCM	-	Counter mode + CBC-MAC
CFR	-	Code of Federal Regulations
CTR	-	Counter mode (encryption)
CW	-	Continuous Wave
DAC	-	Digital to Analog Converter
DSSS	-	Direct Sequence Spread Spectrum
ESD	-	Electro Static Discharge
ESR	-	Equivalent Series Resistance
EVM	-	Error Vector Magnitude
FCC	-	Federal Communications Commission
FCF	-	Frame Control Field
FIFO	-	First In First Out
FFCTRL	-	FIFO and Frame Control
HSSD	-	High Speed Serial Debug
IEEE	-	Institute of Electrical and Electronics Engineers
IF	-	Intermediate Frequency
ISM	-	Industrial, Scientific and Medical
ITU-T	-	International Telecommunication Union – Telecommunication Standardization Sector
I/O	-	Input / Output
I/Q	-	In-phase / Quadrature-phase
kbps	-	kilo bits per second
LNA	-	Low-Noise Amplifier
LO	-	Local Oscillator
LQI	-	Link Quality Indication
LSB	-	Least Significant Bit / Byte
MAC	-	Medium Access Control
MFR	-	MAC Footer
MHR	-	MAC Header
MIC	-	Message Integrity Code
MPDU	-	MAC Protocol Data Unit
MSDU	-	MAC Service Data Unit
NA	-	Not Available
NC	-	No Connect
O-QPSK	-	Offset - Quadrature Phase Shift Keying
PA	-	Power Amplifier
PCB	-	Printed Circuit Board
PER	-	Packet Error Rate
PHY	-	Physical Layer
PHR	-	PHY Header
PLL	-	Phase Locked Loop
PSDU	-	PHY Service Data Unit
QLP	-	Quad Leadless Package
RAM	-	Random Access Memory
RBW	-	Resolution Bandwidth
RF	-	Radio Frequency
RSSI	-	Receive Signal Strength Indicator
RX	-	Receive

SHR	-	Synchronisation Header
SPI	-	Serial Peripheral Interface
TBD	-	To Be Decided / To Be Defined
T/R	-	Transmit / Receive
TX	-	Transmit
VCO	-	Voltage Controlled Oscillator
VGA	-	Variable Gain Amplifier

References

- [1] IEEE std. 802.15.4/D18 - 2003: Wireless Medium Access Control (MAC) and Physical Layer (PHY) specifications for Low Rate Wireless Personal Area Networks (LR-WPANs)
- <http://www.ieee802.org/15/pub/TG4.html>
- [2] NIST FIPS Pub 197: Advanced Encryption Standard (AES), Federal Information Processing Standards Publication 197, US Department of Commerce/N.I.S.T., November 2001. Available from the NIST website.
- <http://csrc.nist.gov/publications/fips/fips197/fips-197.pdf>
- [3] R. Housley, D. Whiting, N. Ferguson, Counter with CBC-MAC (CCM), submitted to NIST, June 3, 2002. Available from the NIST website.
- <http://csrc.nist.gov/publications/fips/fips197/fips-197.pdf>

Features

- 2400 – 2483.5 MHz RF Transceiver
 - Direct Sequence Spread Spectrum (DSSS) transceiver
 - 250 kbps data rate, 2 MChip/s chip rate
 - O-QPSK with half sine pulse shaping modulation
 - Very low current consumption (RX: 19.7 mA, TX: 17.4 mA)
 - High sensitivity (-94 dBm)
 - High adjacent channel rejection (39 dB)
 - High alternate channel rejection (46 dB)
 - On-chip VCO, LNA and PA
 - Low supply voltage (2.1 – 3.6 V) with on-chip voltage regulator
 - Programmable output power
 - I/Q low-IF soft decision receiver
 - I/Q direct up-conversion transmitter

 - Separate transmit and receive FIFOs
 - 128 byte transmit data FIFO
 - 128 byte receive data FIFO

 - Very few external components
 - Only reference crystal and a minimized number of passives
 - No external filters needed

 - Easy configuration interface
 - 4-wire SPI interface
 - Serial clock up to 10 MHz

 - 802.15.4 MAC hardware support:
 - Automatic preamble generator
 - Synchronization word
insertion/detection
 - CRC-16 computation and checking over the MAC payload
-
- Clear Channel Assessment
 - Energy detection / digital RSSI
 - Link Quality Indication
 - Full automatic MAC security (CTR, CBC-MAC, CCM)
-
- 802.15.4 MAC hardware security:
 - Automated security operations within the receive and transmit FIFOs.
 - CTR mode encryption / decryption
 - CBC-MAC authentication
 - CCM encryption / decryption and authentication
 - Stand-alone AES encryption

 - Development tools available
 - Ember Evaluation Kit: A twelve-node evaluation kit designed to allow users to characterize their application environment and familiarize themselves with Ember's Embedded RF solutions and Network Management software.
 - Ember Developer Kit: Everything developers need to create Ember Enabled applications. The Ember Developer Kit includes breakout hardware, Ember RF modules and the EmberNet Stack, a self-organizing, self-healing, flexible networking stack that accommodates mesh, star and hybrid network topologies. The EmberNet Stack is accessible through a straightforward and powerful API.
-
- Small size QLP-48 package, 7 x 7 mm
 - Complies with EN 300 440 and FCC CFR47 part 15, ARIB STD-T-66

Absolute Maximum Ratings

Parameter	Min.	Max.	Units	Condition
Supply voltage, chip core, AVDD/DVDD1.8	-0.3	2.0	V	
Voltage on any pin, core	-0.3	VDD+0.3, max 2.0	V	
Voltage on any pin, digital I/O (pin no. 21, 27-34 and 41)	-0.3	VDDIO+0.3, max 3.6	V	
Input RF level		10	dBm	
Storage temperature range	-50	150	°C	
Lead temperature		260	°C	T = 10 s

The absolute maximum ratings given above should under no circumstances be violated. Stress exceeding one or more of

the limiting values may cause permanent damage to the device.

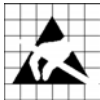

Caution! ESD sensitive device. Precaution should be used when handling the device in order to prevent permanent damage.

Electrical Specifications

T_c = 27°C, DVDD3.3 and VREG_IN = 3.0V, internal voltage regulator used if nothing else stated

Parameter	Min.	Typ.	Max.	Unit	Condition / Note
Overall					
Operating ambient temperature range	-40		85	°C	
RF Frequency Range	2400		2483.5	MHz	Programmable in 1 MHz steps, 5 MHz steps for compliance with [1]
Transmit Section					
Transmit bit rate	250		250	kbps	As defined by [1]
Transmit chip rate	2000		2000	kChips/s	As defined by [1]
Nominal output power	-3	0		dBm	Delivered to a single ended 50 Ω load through a balun. [1] requires minimum -3 dBm
Programmable output power range		40		dB	The output power is programmable in 8 steps from approximately -24 to 0 dBm.
Harmonics 2 nd harmonic 3 rd harmonic		-34 -60		dBc dBc	At max output power delivered to a single ended 50 Ω load through a balun. See page 56.
Spurious emission 30 - 1000 MHz 1 - 12.75 GHz 1.8 - 1.9 GHz 5.15 - 5.3 GHz			-36 -30 -47 -47	dBm dBm dBm dBm	Maximum output power. Complies with EN 300 440, CFR47, Part 15 and ARIB STD-T-66
Error Vector Magnitude (EVM)			20	%	Measured as defined by [1] [1] requires max. 35 %
Optimum load impedance		115 + j180		Ω	Differential impedance as seen from the RF-port (RF_P and RF_N) towards the antenna. For matching details see the Input / Output Matching section on page 56.

Parameter	Min.	Typ.	Max.	Unit	Condition / Note
Receive Section					
Receiver Sensitivity	-90	-94		dBm	PER = 1%, as specified by [1] Measured in 50 Ω single ended through a balun. [1] requires -85 dBm
Saturation (maximum input level)	0	10		dBm	PER = 1%, as specified by [1] Measured in 50 Ω single ended through a balun. [1] requires -20 dBm
Adjacent channel rejection + 5 MHz channel spacing		39		dB	Wanted signal @ -82 dBm, adjacent modulated channel at ± 5 MHz, PER = 1 %, as specified by [1]. [1] requires 0 dB
Adjacent channel rejection - 5 MHz channel spacing		46		dB	Wanted signal @ -82 dBm, adjacent modulated channel at ± 5 MHz, PER = 1 %, as specified by [1]. [1] requires 0 dB
Alternate channel rejection + 10 MHz channel spacing		53		dB	Wanted signal @ -82 dBm, adjacent modulated channel at ± 10 MHz, PER = 1 %, as specified by [1] [1] requires 30 dB
Alternate channel rejection - 10 MHz channel spacing		57		dB	Wanted signal @ -82 dBm, adjacent modulated channel at ± 10 MHz, PER = 1 %, as specified by [1] [1] requires 30 dB
Blocking / Desensitisation* 30 - 2000 MHz 2000 - 2399 MHz 2498 - 3000 MHz 3 – 12.75 GHz (*Out-of-band spurious response rejection)		TBD TBD TBD TBD		dBm dBm dBm dBm	Wanted signal 3 dB above the sensitivity level, CW jammer, PER = 1%.
In-band spurious reception		TBD		dB	Ratio between sensitivity for an unwanted frequency to the sensitivity in the wanted channel. The signal source is a 802.15.4 modulated channel, swept over all channels from 2405 to 2480 MHz. Signal level for PER = 1% Adjacent channels and image channel are excluded.
LO leakage			-47	dBm	

Parameter	Min.	Typ.	Max.	Unit	Condition / Note
Spurious emission 30 – 1 GHz 1 – 12.75 GHz			-57 -47	dBm dBm	Complies with EN 300 440, CFR47, Part 15 and ARIB STD-T-66
Frequency error tolerance	-300		300	kHz	Difference between center frequency of the received RF signal and local oscillator frequency [1] requires 200 kHz
Symbol rate error tolerance			120	ppm	Difference between incoming symbol rate and the internally generated symbol rate [1] requires 80 ppm
RSSI / Carrier Sense					
Carrier sense level		-77		dBm	Programmable in <code>RSSI.CCA_THR</code>
RSSI dynamic range		100		dB	The range is approximately from -100 dBm to 0 dBm
RSSI accuracy		± 6		dB	See page 48 for details
RSSI linearity		± 3		dB	
RSSI average time		128		μs	8 symbol periods, as specified by [1]
IF Section					
Intermediate frequency (IF)		2		MHz	
Frequency Synthesizer Section					
Crystal oscillator frequency		16		MHz	See page 55 for details.
Crystal frequency accuracy requirement	-40		40	ppm	Including aging and temperature dependency, as specified by [1]
Crystal operation		Parallel			C4 and C5 are loading capacitors, see page 55
Crystal load capacitance	12	16	20	pF	16 pF recommended
Crystal ESR			60	Ω	
Crystal oscillator start-up time		0.86		ms	16 pF load

Parameter	Min.	Typ.	Max.	Unit	Condition / Note
Phase noise		-109 -117 -117 -117		dBc/Hz dBc/Hz dBc/Hz dBc/Hz	Unmodulated carrier At ±1 MHz offset from carrier At ±2 MHz offset from carrier At ±3 MHz offset from carrier At ±5 MHz offset from carrier
PLL loop bandwidth		50		kHz	
PLL lock time (RX / TX turnaround time)			192	μs	
Digital Inputs/Outputs					Signal levels are referred to the voltage level at the pin DVDD3.3
Logic "0" input voltage	0		0.3* DVDD	V	
Logic "1" input voltage	0.7* DVDD		DVDD	V	
Logic "0" output voltage	0		0.4	V	Output current -8 mA, 3.3 V supply voltage
Logic "1" output voltage	2.5		VDD	V	Output current 8 mA, 3.3 V supply voltage
Logic "0" input current	NA		-1	μA	Input signal equals GND
Logic "1" input current	NA		1	μA	Input signal equals VDD
FIFO setup time	20			ns	TX un-buffered mode, minimum time FIFO must be ready before the positive edge of FIFOP
FIFO hold time	10			ns	TX un-buffered mode, minimum time FIFO must be held after the positive edge of FIFOP
Serial interface pins (SCLK, SI, SO and CSn) timing specification					See Table 4 on page 26
Voltage Regulator					
Input Voltage	2.1	3.0	3.6	V	On the VREG_IN pin
Output Voltage	1.7	1.8	1.9	V	On the VREG_OUT pin
Quiescent current	13	20	29	μA	No current drawn from the VREG_OUT pin. Min and max numbers include 2.1 through 3.6 V input voltage
Start-up time		0.3	0.6	ms	

Parameter	Min.	Typ.	Max.	Unit	Condition / Note
Battery Monitor					
Current consumption	6	30	90	μA	When enabled
Start-up time			100	μs	Voltage regulator already enabled
Settling time			2	μs	New toggle voltage programmed
Step size			50	mV	
Hysteresis			10	mV	
Absolute accuracy			10	%	May be software calibrated for known reference voltage
Relative accuracy			TBD	%	
Power Supply					
Recommended operation voltage					
RF and analog		1.8		V	Regulated 1.8 V supply voltage generated by on-chip voltage regulator.
Digital core		1.8		V	
Digital I/O		3.0		V	
Supply voltage, operating limits					
RF and analog	1.6		2.0	V	Regulated 1.8 V supply voltage generated by on-chip voltage regulator. The digital I/O voltage (DVDD3, 3 pin) must match the external interfacing circuit (e.g. microcontroller).
Digital core	1.6		2.0	V	
Digital I/O	1.6		3.6	V	
Voltage regulator input	2.1		3.6		
Current consumption in different modes (see Figure 23, page 43)					Current drawn from VREG_IN, through voltage regulator
Power Down mode (OFF)			1	μA	Voltage regulator off
Idle mode (IDLE)		20		μA	Voltage regulator on
Crystal oscillator on (XOSC_ON)		365		μA	Including voltage regulator
Current Consumption, receive mode		19.7		mA	
Current Consumption, transmit mode:					
P = -25 dBm		8.5		mA	The output power is delivered differentially to a 50 Ω singled ended load through a balun, see also page 56.
P = -15 dBm		9.9		mA	
P = -10 dBm		11		mA	
P = -5 dBm		14		mA	
P = 0 dBm		17.4		mA	

Pin Assignment

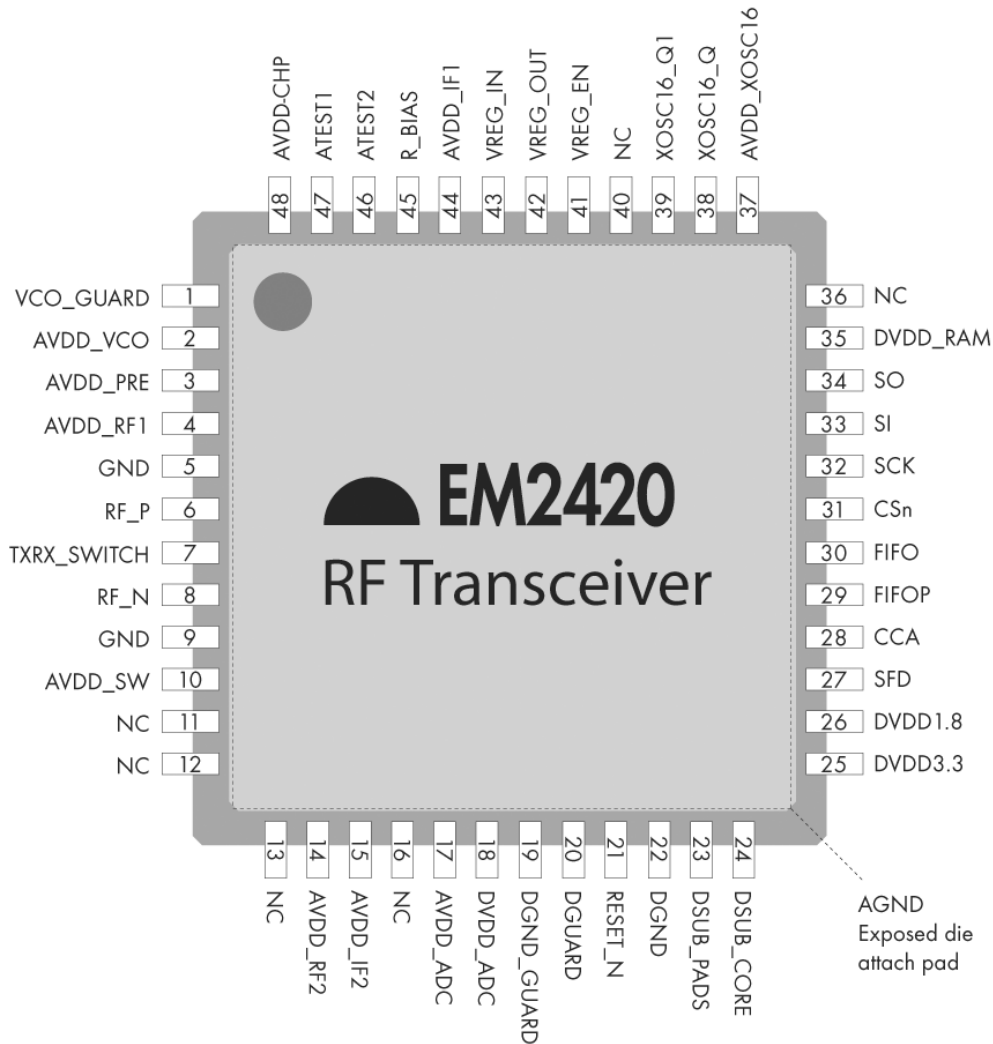

Figure 1. The EM2420 Pinout – Top View

Pin	Pin Name	Pin type	Pin Description
-	AGND	Ground (analog)	Exposed die attach pad. Must be connected to solid ground plane
1	VCO_GUARD	Power (analog)	Connection of guard ring for VCO (to AVDD) shielding
2	AVDD_VCO	Power (analog)	1.8 V Power supply for VCO
3	AVDD_PRE	Power (analog)	1.8 V Power supply for Prescaler
4	AVDD_RF1	Power (analog)	1.8 V Power supply for RF front-end
5	GND	Ground (analog)	Grounded pin for RF shielding
6	RF_P	RF I/O	Positive RF input/output signal to LNA/from PA in receive/transmit mode

Pin	Pin Name	Pin type	Pin Description
7	TXRX_SWITCH	Power (analog)	Common supply connection for integrated RF front-end. Must be connected to RF_P and RF_N externally through a DC path
8	RF_N	RF I/O	Negative RF input/output signal to LNA/from PA in receive/transmit mode
9	GND	Ground (analog)	Grounded pin for RF shielding
10	AVDD_SW	Power (analog)	1.8 V Power supply for LNA / PA switch
11	NC	-	No Connect
12	NC	-	No Connect
13	NC	-	No Connect
14	AVDD_RF2	Power (analog)	1.8 V Power supply for receive and transmit mixers
15	AVDD_IF2	Power (analog)	1.8 V Power supply for transmit / receive IF chain
16	NC	-	No Connect
17	AVDD_ADC	Power (analog)	1.8 V Power supply for analog parts of ADCs and DACs
18	DVDD_ADC	Power (digital)	1.8 V Power supply for digital parts of receive ADCs
19	DGND_GUARD	Ground (digital)	Ground connection for digital noise isolation
20	DGUARD	Power (digital)	1.8 V Power supply connection for digital noise isolation
21	RESETn	Digital Input	Asynchronous, active low digital reset
22	DGND	Ground (digital)	Ground connection for digital core and pads
23	DSUB_PADS	Ground (digital)	Substrate connection for digital pads
24	DSUB_CORE	Ground (digital)	Substrate connection for digital modules
25	DVDD3.3	Power (digital)	3.3 V Power supply for digital I/Os
26	DVDD1.8	Power (digital)	1.8 V Power supply for digital core
27	SFD	Digital output	SFD (Start of Frame Delimiter) / digital mux output
28	CCA	Digital output	CCA (Clear Channel Assessment) / digital mux output
29	FIFOP	Digital output	High when number of bytes in FIFO exceeds threshold / serial RF clock output in test mode
30	FIFO	Digital I/O	High when data in FIFO / serial RF data input / output in test mode
31	CSn	Digital input	SPI Chip select, active low
32	SCLK	Digital input	SPI Clock input, up to 10 MHz
33	SI	Digital input	SPI Slave Input. Sampled on the positive edge of SCLK
34	SO	Digital output (tristate / pullup)	SPI Slave Output. Updated on the negative edge of SCLK. Tristate when CSn high. Programmable internal pullup
35	DVDD_RAM	Power (digital)	1.8 V Power supply for digital RAM
36	NC	-	No Connect
37	AVDD_XOSC16	Power (analog)	1.8 V crystal oscillator power supply
38	XOSC16_Q2	Analog I/O	16 MHz Crystal oscillator pin 2
39	XOSC16_Q1	Analog I/O	16 MHz Crystal oscillator pin 1 or external clock input
40	NC	-	No Connect
41	VREG_EN	Digital input	Voltage regulator enable, active high, held at VREG_IN voltage level when active
42	VREG_OUT	Power output	Voltage regulator 1.8 V power supply output
43	VREG_IN	Power (analog)	Voltage regulator 2.1 to 3.6 V power supply input
44	AVDD_IF1	Power (analog)	1.8 V Power supply for transmit / receive IF chain
45	R_BIAS	Analog output	External precision resistor, 43 kΩ, ± 1 %
46	ATEST2	Analog I/O	Analog test I/O for prototype and production testing
47	ATEST1	Analog I/O	Analog test I/O for prototype and production testing
48	AVDD_CHP	Power (analog)	1.8 V Power supply for phase detector and charge pump

NOTES:

The exposed die attach pad **must** be connected to solid ground plane as this is the main ground connection for the chip.

Note that digital inputs SCLK, SI and CSn are high-impedance inputs (no internal pull-up) and should have external pull-ups if not driven. SO is high-impedance when CSn is high. External pull-up should be used at SO to prevent floating input at microcontroller or the internal SO-pin pull-up should be enabled.

Circuit Description

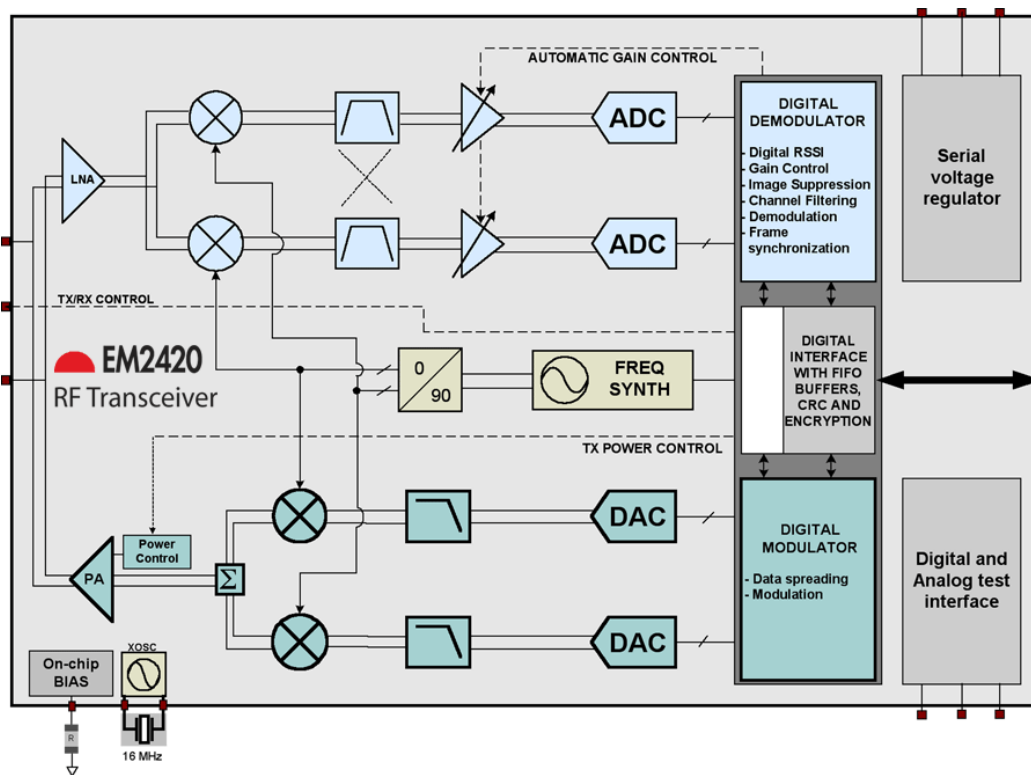

Figure 2. The EM2420 simplified block diagram

A simplified block diagram of the **EM2420** is shown in Figure 2.

The **EM2420** features a low-IF receiver. The received RF signal is amplified by the low-noise amplifier (LNA) and down-converted in quadrature (I and Q) to the intermediate frequency (IF). At IF (2 MHz), the complex I/Q signal is filtered and amplified, and then digitized by the ADCs. Automatic gain control, final channel filtering, de-spreading, symbol correlation and byte synchronization are performed digitally.

When the *SFD* pin goes high, this indicates that a start of frame delimiter has been detected. The **EM2420** buffers the received data in a 128 byte receive FIFO. The user may read the FIFO through a SPI interface. CRC is verified in hardware. RSSI and correlation values are appended to the frame. CCA is available on a pin in receive mode. Serial (unbuffered) data

modes are also available for test purposes.

The **EM2420** transmitter is based on direct up-conversion. The data is buffered in a 128 byte transmit FIFO (separate from the receive FIFO). The preamble and start of frame delimiter are generated by hardware. Each symbol (4 bits) is spread using the IEEE 802.15.4 spreading sequence to 32 chips and output to the digital-to-analog converters (DACs).

An analog lowpass filter passes the signal to the quadrature (I and Q) upconversion mixers. The RF signal is amplified in the power amplifier (PA) and fed to the antenna.

The internal T/R switch circuitry makes the antenna interface and matching very easy. The RF connection is differential. A balun may be used for single-ended antennas. The biasing of the PA and LNA is done by

connecting `RXTX_SWITCH` to `RF_P` and `RF_N` through an external DC path.

The frequency synthesizer includes a completely on-chip LC VCO and a 90 degrees phase splitter for generating the I and Q LO signals to the down-conversion mixers in receive mode and up-conversion mixers in transmit mode. The VCO operates in the frequency range 4800 – 4966 MHz, and the frequency is divided by two when split in I and Q.

A crystal must be connected to `XOSC16_Q1` and `XOSC16_Q2` and provides the reference frequency for the synthesizer. A digital lock signal is available from the PLL.

The digital baseband includes support for frame handling, address recognition, data buffering and MAC security.

The 4-wire SPI serial interface is used for configuration and data buffering.

An on-chip voltage regulator delivers the regulated 1.8 V supply voltage. The voltage regulator may be enabled / disabled through a separate pin.

A battery monitor may optionally be used to monitor the unregulated power supply voltage. The battery monitor is configurable through the SPI interface.

Application Circuit

Few external components are required for the operation of the **EM2420**. A typical application circuit is shown in Figure 3. The external components are described in Table 1 and typical values are given in Table 2.

Input / output matching

The RF input/output is high impedance and differential. The optimum differential load for the RF port is $115+j180\ \Omega$.

When using an unbalanced antenna such as a monopole, a balun should be used in order to optimize performance. The balun can be implemented using low-cost discrete inductors and capacitors. The balun consists of C61, C62, C71, C81, L61, L62 and L72, and will match the RF input/output to $50\ \Omega$, see Figure 3. L61 and L62 also provide DC biasing of the LNA/PA input/output. An internal T/R switch circuit is used to switch between the LNA and the PA. See Input/output matching section on page 55 for more details.

If a balanced antenna such as a folded dipole is used, the balun can be omitted. If the antenna also provides a DC path from `TXRX_SWITCH` pin to the RF pins, inductors are not needed for DC bias.

Figure 4 shows a typical application circuit with differential antenna. The dipole has a virtual ground point, hence bias is

provided without degradation in antenna performance.

A 27 nH series inductor may be connected to the `TXRX_SWITCH` pin to improve the transmitted EVM, but is not necessary to comply with the requirements in [1].

Bias resistor

The bias resistor R451 is used to set an accurate bias current.

Crystal

An external crystal with two loading capacitors (C381 and C391) is used for the crystal oscillator. See page 55 for details.

Voltage regulator

The on chip voltage regulator supplies all 1.8 V power supply inputs. C42 is required for stability of the regulator. A series resistor may be used to comply with the ESR requirement.

Power supply decoupling and filtering

Proper power supply decoupling must be used for optimum performance. The placement and size of the decoupling capacitors and the power supply filtering are very important to achieve the best performance in an application. Ember provides a compact reference design that should be followed very closely.

Ref	Description
C42	Voltage regulator load capacitance
C61	Discrete balun and match, see page 55
C62	DC block to antenna and match
C71	Front-end bias decoupling and match, see page 55
C81	Discrete balun and match, see page 55
C381	16MHz crystal load capacitor, see page 55
C391	16MHz crystal load capacitor, see page 55
L61	DC bias and match, see page 55
L62	DC bias and match, see page 55
L81	Discrete balun and match, see page 55
R451	Precision resistor for current reference generator
XTAL	16MHz crystal, see page 55

Table 1. Overview of external components

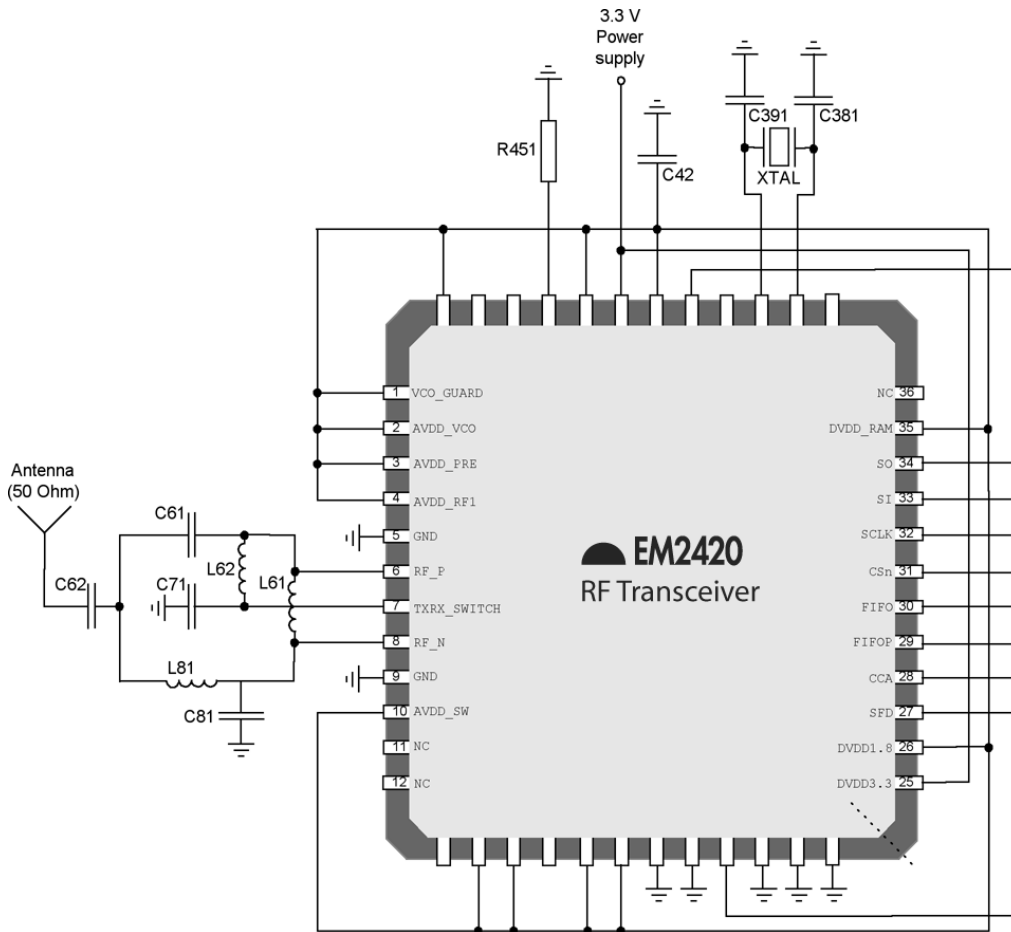

Figure 3. Typical application circuit with discrete balun for single-ended operation

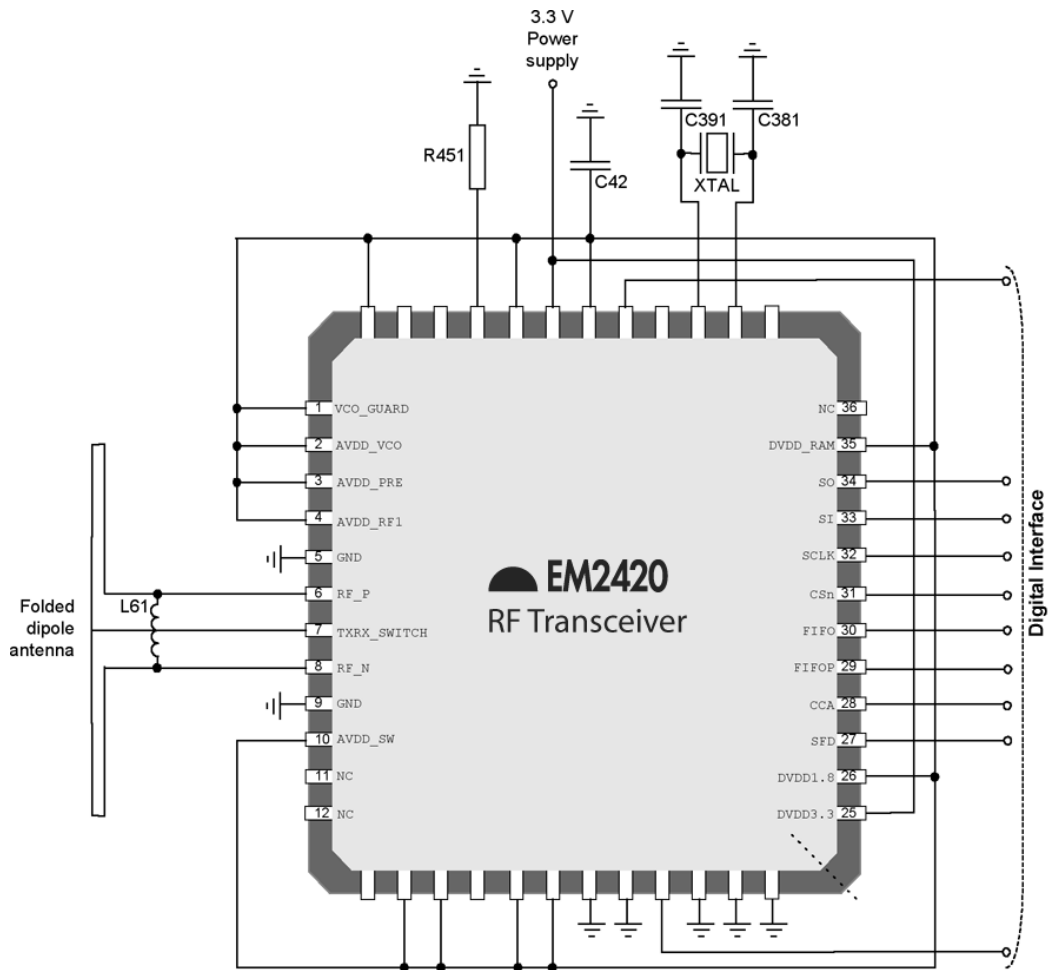

Figure 4. Typical application circuit with differential antenna (folded dipole)

Item	Single ended output, discrete balun	Differential antenna
C42	10 μ F, $0.5\Omega < \text{ESR} < 5\Omega$	10 μ F, $0.5\Omega < \text{ESR} < 5\Omega$
C61	0.5 pF, +/- 0.25pF, NP0, 0402	Not used
C62	5.6 pF, +/- 0.25pF, NP0, 0402	Not used
C71	5.6 pF, 10%, X5R, 0402	5.6 pF, 10%, X5R, 0402
C81	0.5 pF, +/- 0.25pF, NP0, 0402	Not used
C381	22 pF, 5%, NP0, 0402	22 pF, 5%, NP0, 0402
C391	22 pF, 5%, NP0, 0402	22 pF, 5%, NP0, 0402
L61	7.5 nH, 5%, Monolithic/multilayer, 0402	27 nH, 5%, Monolithic/multilayer, 0402
L62	5.6 nH, 5%, Monolithic/multilayer, 0402	Not used
L81	7.5 nH, 5%, Monolithic/multilayer, 0402	Not used
R451	43 k Ω , 1%, 0402	43 k Ω , 1%, 0402
XTAL	16 MHz crystal, 16 pF load (C_L), ESR < 60 Ω	16 MHz crystal, 16 pF load (C_L), ESR < 60 Ω

Table 2. Bill of materials for the application circuits

IEEE 802.15.4 Modulation Format

This section is meant as an introduction to the 2.4 GHz direct sequence spread spectrum (DSSS) RF modulation format defined in IEEE 802.15.4. For a complete description, please refer to [1].

The modulation and spreading functions are illustrated at block level in Figure 5 [1]. Each byte is divided into two symbols, 4 bits each. The least significant symbol is transmitted first. For multi-byte fields, the

least significant byte is transmitted first, except for security related fields where the most significant byte is transmitted first.

Each symbol is mapped to one out of 16 pseudo-random sequences, 32 chips each. The chip to symbol mapping is shown in Table 3. The chip sequence is then transmitted at 2 MChips/s, with the least significant chip (C_0) transmitted first for each symbol.

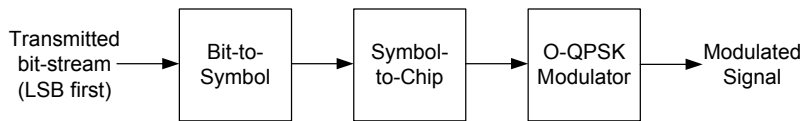

Figure 5. Modulation and spreading functions [1]

Symbol	Chip sequence ($C_0, C_1, C_2, \dots, C_{31}$)
0	1 1 0 1 1 0 0 1 1 1 1 0 0 0 0 1 1 0 1 0 1 0 0 1 0 0 0 1 0 1 1 1 0
1	1 1 1 0 1 1 0 1 1 0 0 1 1 1 1 0 0 0 0 1 1 0 1 0 1 0 0 1 0 0 0 1 0
2	0 0 1 0 1 1 1 0 1 1 0 1 1 0 0 1 1 1 1 0 0 0 0 1 1 0 1 0 1 0 0 1 0
3	0 0 1 0 0 0 1 0 1 1 1 0 1 1 0 1 1 0 0 1 1 1 1 0 0 0 0 1 1 0 1 0 1
4	0 1 0 1 0 0 1 0 0 0 1 0 1 1 1 0 1 1 0 1 1 0 0 1 1 1 1 0 0 0 0 1 1
5	0 0 1 1 0 1 0 1 0 0 1 0 0 0 1 0 1 1 1 0 1 1 0 1 1 0 0 1 1 1 0 0
6	1 1 0 0 0 0 1 1 0 1 0 1 0 0 1 0 0 0 1 0 1 1 1 0 1 1 0 1 1 0 0 1
7	1 0 0 1 1 1 0 0 0 0 1 1 0 1 0 1 0 0 1 0 0 0 1 0 1 1 1 0 1 1 0 1
8	1 0 0 0 1 1 0 0 1 0 0 1 0 1 1 0 0 0 0 0 0 1 1 1 0 1 1 1 1 0 1 1
9	1 0 1 1 1 0 0 0 1 1 0 0 1 0 0 1 0 1 1 0 0 0 0 0 0 1 1 1 0 1 1 1
10	0 1 1 1 1 0 1 1 1 0 0 0 1 1 0 0 1 0 0 1 0 1 1 1 0 0 0 0 0 0 1 1 1
11	0 1 1 1 0 1 1 1 1 0 1 1 1 0 0 0 1 1 0 0 1 0 0 1 0 1 1 0 0 0 0 0
12	0 0 0 0 0 1 1 1 0 1 1 1 1 0 1 1 1 0 0 0 1 1 0 0 1 0 0 1 0 1 1 0
13	0 1 1 0 0 0 0 0 0 1 1 1 0 1 1 1 1 0 1 1 1 0 0 0 1 1 0 0 1 0 0 1
14	1 0 0 1 0 1 1 0 0 0 0 0 0 1 1 1 0 1 1 1 1 0 1 1 1 0 0 0 1 1 0 0
15	1 1 0 0 1 0 0 1 0 1 1 0 0 0 0 0 0 1 1 1 0 1 1 1 1 0 1 1 1 0 0 0

Table 3. IEEE 802.15.4 symbol-to-chip mapping [1]

The modulation format is Offset – Quadrature Phase Shift Keying (O-QPSK) with half-sine chip shaping. This is equivalent to MSK modulation. Each chip

is shaped as a half-sine, transmitted alternately in the I and Q channels with one half chip period offset. This is illustrated for the zero-symbol in Figure 6.

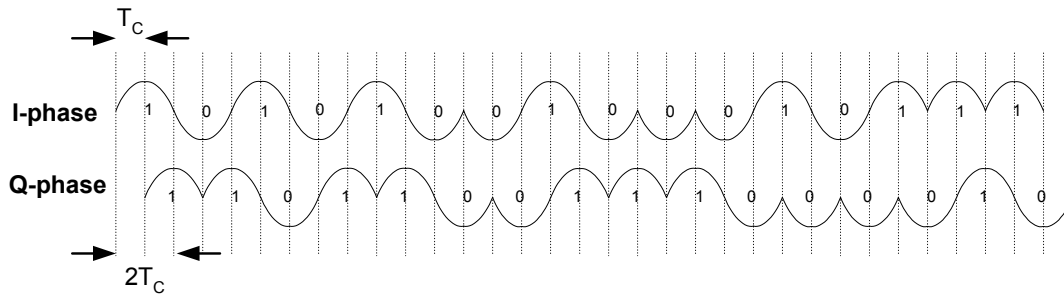

Figure 6. I / Q Phases when transmitting a zero-symbol chip sequence, $T_c = 0.5 \mu s$

Configuration Overview

The **EM2420** can be configured to achieve the best performance for different applications. Through the programmable configuration registers the following key parameters can be programmed:

- Receive / transmit mode
- RF channel selection
- RF output power
- Power-down / power-up mode
- Crystal oscillator power-up / power down
- Clear Channel Assessment mode
- Packet handling hardware support
- Encryption / Authentication modes

Evaluation Software

Ember provides users of the **EM2420** with EmberNet Studio, a Windows interface

program that may be used for performance evaluation. Figure 7 shows the user interface of EmberNet Studio.

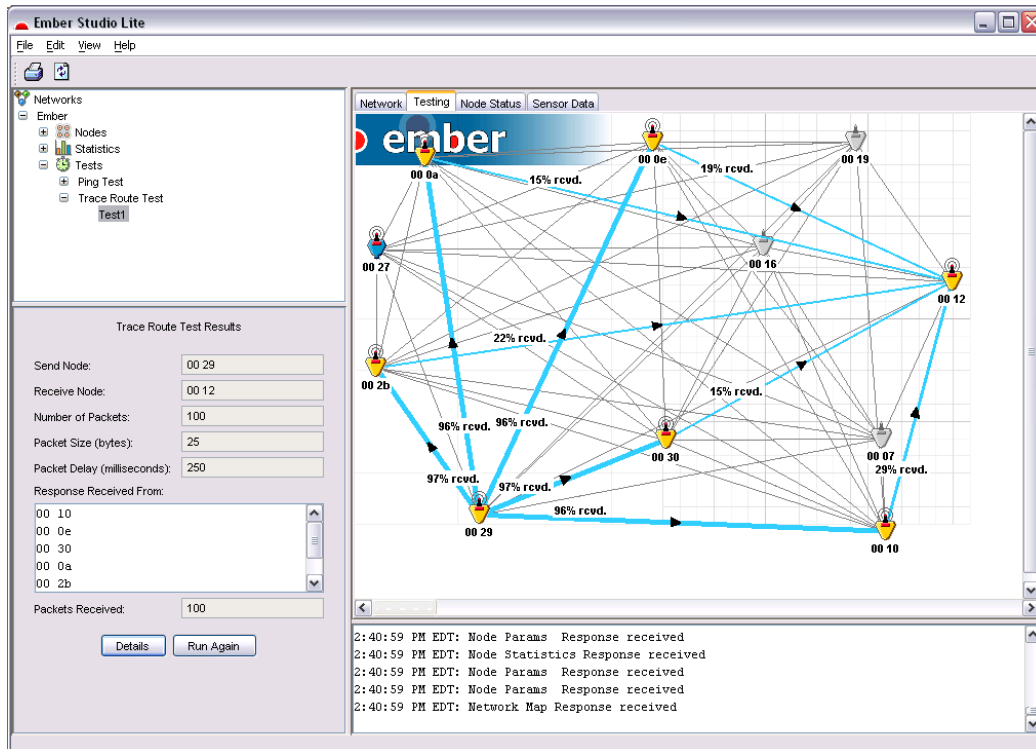

Figure 7. EmberNet Studio user interface

4-wire Serial Configuration and Data Interface

The **EM2420** is configured via a simple 4-wire SPI-compatible interface (pins **SI**, **SO**, **SCLK** and **CS_n**) where the **EM2420** is the slave. This interface is also used to read and write buffered data (see page 37). All address and data transfer on the SPI interface is done most significant bit first.

Register access

There are 33 16-bit configuration and status registers, 15 command strobe registers, and two 8-bit registers to access the separate transmit and receive FIFOs. Each of the 50 registers is addressed by a 6-bit address. The RAM/Register bit (bit 7) must be cleared for register access. The Read/Write bit (bit 6) selects a read or a write operation and makes up the 8-bit address field together with the 6-bit address.

In each register read or write cycle, 24 bits are sent on the SI-line. The **CS_n** pin (Chip Select, active low) must be kept low during this transfer. The bit to be sent first is the RAM/Register bit (set to 0 for register access), followed by the R/W bit (0 for write, 1 for read). The following 6 bits are the address-bits (A5:0). A5 is the most significant bit of the address and is sent first. The 16 data-bits are then transferred

(D15:0), also MSB first. See Figure 8 for an illustration.

The configuration registers can also be read by the microcontroller via the same configuration interface. The R/W bit must be set high to initiate the data read-back. The **EM2420** then returns the data from the addressed register on the 16 clock cycles following the register address. The **SO** pin is used as the data output and must be configured as an input by the microcontroller.

The timing for the programming is also shown in Figure 8 with reference to Table 4. The clocking of the data on **SI** into the **EM2420** is done on the positive edge of **SCLK**. When the last bit, D0, of the 16 data-bits has been written, the data word is loaded in the internal configuration register.

Multiple registers may be written without releasing **CS_n**, as described in the Multiple SPI access section on page 29.

The register data will be retained during a programmed power-down mode, but not when the power-supply is turned off (e.g. by disabling the voltage regulator using the **VREG_EN** pin). The registers can be programmed in any order.

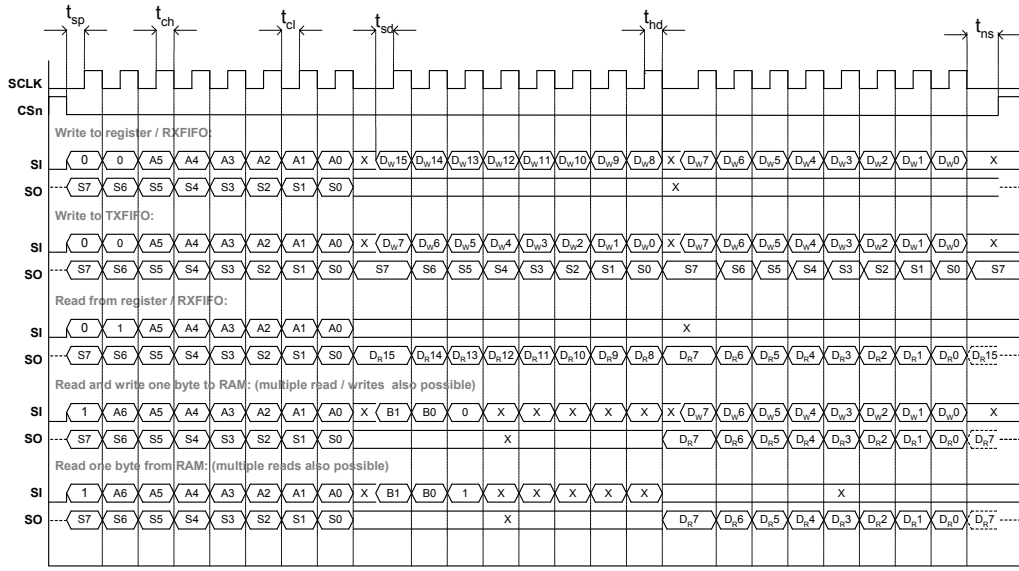

Figure 8. SPI timing diagram

Parameter	Symbol	Min	Max	Units	Conditions
SCLK, clock frequency	F_{SCLK}		10	MHz	
SCLK low pulse duration	t_{cl}	25		ns	The minimum time SCLK must be low.
SCLK high pulse duration	t_{ch}	25		ns	The minimum time SCLK must be high.
CSn setup time	t_{sp}	25		ns	The minimum time CSn must be low before the first positive edge of SCLK.
CSn hold time	t_{ns}	25		ns	The minimum time CSn must be held low after the last negative edge of SCLK.
SI setup time	t_{sd}	25		ns	The minimum time data on SI must be ready before the positive edge of SCLK.
SI hold time	t_{hd}	25		ns	The minimum time data must be held at SI, after the positive edge of SCLK.
Rise time	t_{rise}		100	ns	The maximum rise time for SCLK and CSn
Fall time	t_{fall}		100	ns	The maximum fall time for SCLK and CSn

Note: The set-up- and hold-times refer to 50% of VDD.

Table 4. SPI timing specification

Status byte

During transfer of the register access byte, command strobes, the first RAM address byte and data transfer to the TXFIFO, the **EM2420** status byte is returned on the SO

pin. The status byte contains 6 status bits which are described in Table 5.

Issuing a **SNOP** (no operation) command strobe may be used to read the status byte. It may also be read during access to

chip functions such as register or FIFO access.

Bit #	Name	Description
7	-	Reserved, ignore value
6	XOSC16M_STABLE	Indicates whether the 16 MHz oscillator is running or not 0 : The 16 MHz crystal oscillator is not running 1 : The 16 MHz crystal oscillator is running
5	TX_UNDERFLOW	Indicates whether an FIFO underflow has occurred during transmission. Must be cleared manually with a SFLUSHTX command strobe. 0 : No underflow has occurred 1 : An underflow has occurred
4	ENC_BUSY	Indicates whether the encryption module is busy 0 : Encryption module is idle 1 : Encryption module is busy
3	TX_ACTIVE	Indicates whether RF transmission is active 0 : RF Transmission is idle 1 : RF Transmission is active
2	LOCK	Indicates whether the frequency synthesizer PLL is in lock or not 0 : The PLL is out of lock 1 : The PLL is in lock
1	RSSI_VALID	Indicates whether the RSSI value is valid or not. 0 : The RSSI value is not valid 1 : The RSSI value is valid, always true when reception has been enabled at least 8 symbol periods (128 us)
0	-	Reserved, ignore value

Table 5. Status byte returned during address transfer and TXFIFO writing

Command strobes

Command strobes may be viewed as single byte instructions to the **EM2420**. By addressing a command strobe register internal sequences will be started. These commands must be used to enable the crystal oscillator, enable receive mode, start decryption etc. All 15 command strobes are listed in Table 11 on page 64.

When the crystal oscillator is disabled (IDLE state in Figure 23 on page 43), only the SXOSCON command strobe may be used. All other command strobes will be ignored and will have no effect. The crystal oscillator must stabilize (see the XOSC16M_STABLE status bit in Table 5) before other command strobes are accepted.

The command strobe register is accessed in the same way as for a register write operation, but no data is transferred. That is, only the RAM/Register bit (set to 0),

R/W bit (set to 0) and the 6 address bits (in the range 0x00 through 0x0E) are written. A command strobe may be followed by any other SPI access without pulling CS_n high, and is executed on the last falling edge on SCLK.

RAM access

The internal 368 byte RAM may be accessed through the SPI interface. Single or multiple bytes may be read or written sending the address part (2 bytes) only once. The address is then automatically incremented by the **EM2420** hardware for each new byte. Data is read and written one byte at a time, unlike register access where 2 bytes are always required after each address byte.

The crystal oscillator must be running when accessing the RAM.

The RAM/Register bit must be set high to enable RAM access. The 9 bit RAM

address consists of two parts, B1:0 (MSB) selecting one of the three memory banks and A7:0 (LSB) selecting the address within the selected bank. The RAM is divided into three memory banks: TXFIFO (bank 0), RXFIFO (bank 1) and security (bank 2). The FIFO banks are 128 bytes each, while the security bank is 112 bytes.

A6:0 is transmitted directly after the RAM/Register bit as shown in Figure 8. For RAM access, a second byte is also required before the data transfer. This byte contains B1:0 in bits 7 and 6, followed by the R/W bit (0 for read+write, 1 for read). Bits 4 through 0 are don't care as shown in Figure 8.

For RAM write, data to be written must be input on the SI pin directly after the second address byte. RAM data read is

output on the SO pin simultaneously, but may be ignored by the user if only writing is of interest.

For RAM read, the selected byte(s) are output on the SO pin directly after the second address byte.

See Figure 9 for an illustration on how multiple RAM bytes may be read or written in one operation.

The RAM memory space is shown in Table 6.

As with register data, data stored in RAM will be retained during a programmed power-down mode, but not when the power-supply is turned off (e.g. by disabling the voltage regulator using the VREG_EN pin).

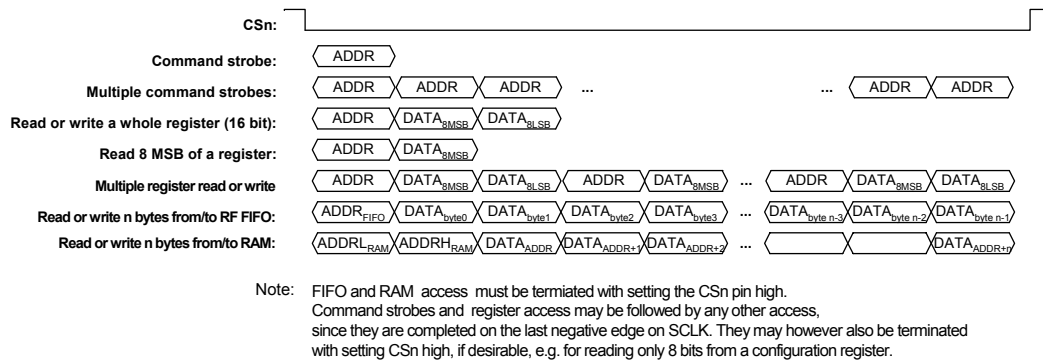

Figure 9. Configuration registers write and read operations via SPI

Address	Byte Ordering	Name	Description
0x16F – 0x16C	-	-	Not used
0x16B – 0x16A	MSB LSB	SHORTADR	16-bit Short address, used for address recognition.
0x169 – 0x168	MSB LSB	PANID	16-bit PAN identifier, used for address recognition.
0x167 – 0x160	MSB LSB	IEEEADR	64-bit IEEE address of current node, used for address recognition.
0x15F – 0x150	MSB LSB	CBCSTATE	Temporary storage for CBC-MAC calculations
0x14F – 0x140	MSB (Flags) LSB	TXNONCE / TXCTR	Transmitter nonce for in-line authentication and transmitter counter for in-line encryption.
0x13F – 0x130	MSB LSB	KEY1	Encryption key 1
0x12F – 0x120	MSB LSB	SABUF	Stand-alone encryption buffer, for plaintext input and ciphertext output
0x11F – 0x110	MSB (Flags) LSB	RXNONCE / RXCTR	Receiver nonce for in-line authentication or receiver counter for in-line decryption.
0x10F – 0x100	MSB LSB	KEY0	Encryption key 0
0x0FF – 0x080	MSB LSB	RXFIFO	128 bytes receive FIFO
0x07F – 0x000	MSB LSB	TXFIFO	128 bytes transmit FIFO

Table 6. The EM2420 RAM Memory Space

FIFO access

The TXFIFO and RXFIFO may be accessed through the TXFIFO (0x3E) and RXFIFO (0x3F) registers.

The TXFIFO is write only, but may be read back using RAM access as described in the previous section. Data is read and written one byte at a time, as with RAM access. The RXFIFO is both writable and readable. Writing to the RXFIFO should however only be done for debugging or for using the RXFIFO for security operations (decryption / authentication).

The crystal oscillator must be running when accessing the FIFOs.

When writing to the TXFIFO, the status byte (see Table 5) is output for each new data byte on SO, as shown in Figure 8. This could be used to detect TXFIFO underflow (see section RF Data Buffering section on page 37) while writing data to the TXFIFO.

Multiple FIFO bytes may be accessed in one operation, as with the RAM access. FIFO access can only be terminated by setting the CSn pin high once it has been started.

The FIFO and FIFOP pins also provide additional information on the data in the receive FIFO, as will be described in the Microcontroller Interface and Pin Description section on page 30. Note that the FIFO and FIFOP pins only apply to the RXFIFO. The TXFIFO has its underflow flag in the status byte.

The TXFIFO may be flushed by issuing a STXFLUSH command strobe. Similarly, a SRXFLUSH command strobe will flush the receive FIFO.

Multiple SPI access

Register access, command strobes, FIFO access and RAM access may be issued continuously without setting CSn high. E.g. the user may issue a command strobe, a register write and writing 3 bytes to the TXFIFO in one operation, as

illustrated in Figure 10. The only exception is that FIFO and RAM access must be

terminated by setting CS_n high.

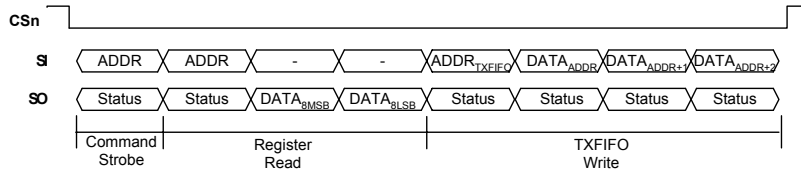

Figure 10. Multiple SPI Access Example

Microcontroller Interface and Pin Description

When used in a typical system, the **EM2420** will interface to a microcontroller. This microcontroller must be able to:

- Program the **EM2420** into different modes, read and write buffered data, and read back status information via the 4-wire SPI-bus configuration interface (SI , SO , $SCLK$ and CS_n).
- Interface to the receive and transmit FIFOs using the $FIFO$ and $FIFOP$ status pins.
- Interface to the CCA pin for clear channel assessment.
- Interface to the SFD pin for timing information (particularly for beaconing networks).

Configuration interface

An **EM2420**-to-microcontroller interface example is shown in Figure 11. The microcontroller uses 4 I/O pins for the SPI configuration interface (SI , SO , $SCLK$ and

CS_n). SO should be connected to an input at the microcontroller. SI , $SCLK$ and CS_n must be microcontroller outputs. Preferably the microcontroller should have a hardware SPI interface.

The microcontroller pins connected to SI , SO and $SCLK$ can be shared with other SPI-interface devices. SO is a high impedance output as long as CS_n is not activated (active low). An internal pull-up on the SO pin may be enabled in the $IOCFG0.SO_PULLUP$ configuration bit.

CS_n should have an external pull-up resistor or be set to a high level during power down mode in order to prevent the input from floating. SI and $SCLK$ should be set to a defined level to prevent the inputs from floating.

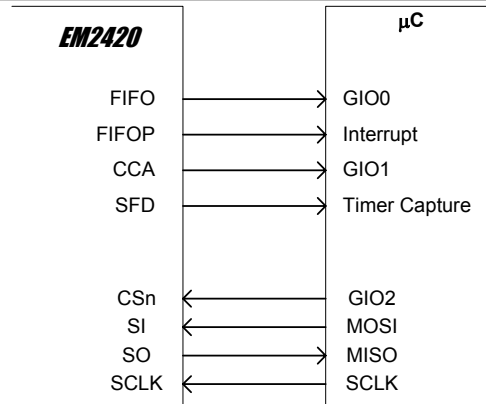

Figure 11. Microcontroller interface example

Receive mode

In receive mode, the *SFD* pin goes high after the start of frame delimiter (SFD) field has been completely received. If address recognition is disabled or is successful, the *SFD* pin goes low again only after the last byte of the MPDU has been received. If the received frame fails address recognition, the *SFD* pin goes low immediately. This is illustrated in Figure 12.

The *FIFO* pin is high when there are one or more data bytes in the RXFIFO. The first byte to be stored in the RXFIFO is the length field of the received frame, i.e. the *FIFO* pin is set high when the length field is written to the RXFIFO. The *FIFO* pin then remains high until the RXFIFO is empty.

If a previously received frame is completely or partially inside the RXFIFO, the *FIFO* pin will remain high until the RXFIFO is empty.

When address recognition is enabled, data should not be read out of the RXFIFO before the address is completely received, since the frame may be automatically flushed if it fails address recognition. This may be handled by using the *FIFOP* pin

RXFIFO overflow

The RXFIFO can only contain a maximum of 128 bytes at a given time. This may be divided between multiple frames, as long

as the total number of bytes is 128 or less. If an overflow occurs in the RXFIFO, this is signaled to the microcontroller by setting the *FIFO* pin low while the *FIFOP* pin is high. Data already in the RXFIFO will not be affected by the overflow, i.e. frames already received may be read out.

A *SFLUSHRX* command strobe is required after a RXFIFO overflow to enable reception of new data. Note that at least one byte should be read from the RXFIFO prior to issuing the *SFLUSHRX* command strobe. Otherwise the FIFO will be flushed, but the *FIFOP* pin will not go low before a byte is read.

For security enabled frames, the MAC layer must read the source address of the received frame before it can decide which key to use to decrypt or authenticate. This data must therefore not be overwritten even if it has been read out of the RXFIFO by the microcontroller. If the *SECCTRL0.RXFIFO_PROTECTION* control bit is set, the **EM2420** also protects the frame header of security enabled frames until decryption has been performed. If no MAC security is used or if it is implemented outside the **EM2420**, this bit may be cleared to achieve optimal use of the RXFIFO.

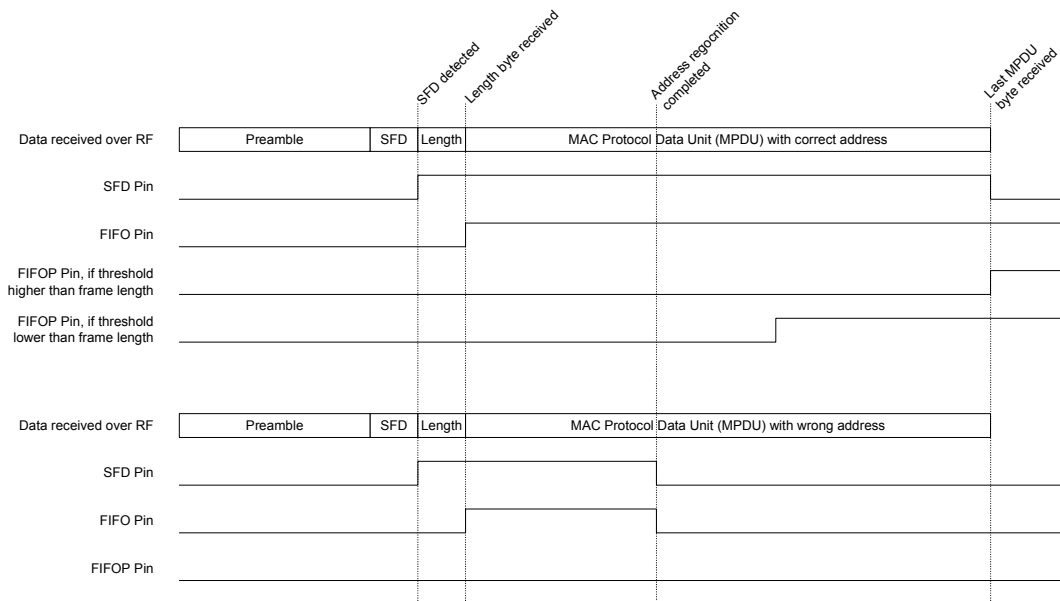

Figure 12. Pin activity examples during receive

Transmit mode

During transmit, the `FIFO` and `FIFOP` pins are still only related to the `RXFIFO`. The `SFD` pin is however active during transmission of a data frame, as shown in Figure 13.

The `SFD` pin goes high when the SFD field has been completely transmitted. It goes low again when the complete MPDU (as defined by the length field) has been transmitted or if an underflow is detected.

See the RF Data Buffering section on page 37 for more information on `TXFIFO` underflow.

As can be seen from comparing Figure 12 and Figure 13, the `SFD` pin behaves very similarly during reception and transmission of a data frame. If the `SFD` pins of the transmitter and the receiver are compared during the transmission of a data frame, a small delay of approximately 2 μ s can be seen because of bandwidth limitations in both the transmitter and the receiver.

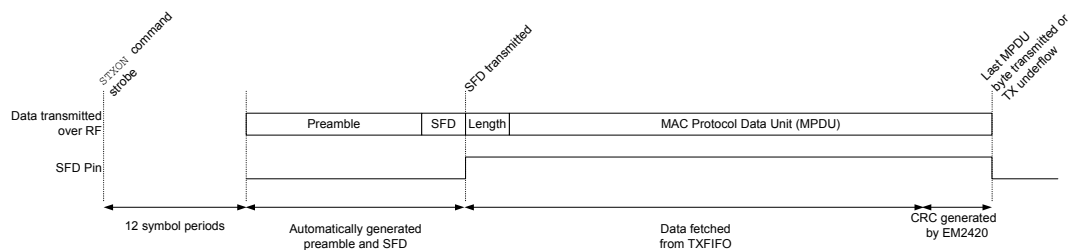

Figure 13. Pin activity example during transmit

General control and status pins

In receive mode, the `FIFOP` pin can be used to interrupt the microcontroller when a threshold has been exceeded or a

complete frame has been received. This pin should then be connected to a microcontroller interrupt pin.

In receive mode, the `FIFO` pin can be used to detect if there is data at all in the receive `FIFO`.

The `SFD` pin can be used to extract the timing information of transmitted and received data frames. The `SFD` pin will go high when a start of frame delimiter has been completely detected / transmitted. The `SFD` pin should preferably be connected to a timer capture pin on the microcontroller.

For debug purposes, the `SFD` and `CCA` pins can be used to monitor several status signals as selected by the `IOCFG1` register. See Table 12 for available signals.

The polarity of `FIFO`, `FIFOP`, `SFD` and `CCA` can be controlled by the `IOCFG0` register (address 0x1C).

Demodulator, Symbol Synchronizer and Data Decision

The block diagram for the **EM2420** demodulator is shown in Figure 14. Channel filtering and frequency offset compensation is performed digitally. The signal level in the channel is estimated to generate the RSSI level (see the RSSI / Energy Detection section on page 48 for more information). Data filtering is also included for enhanced performance.

With the ± 40 ppm frequency accuracy requirement from [1], a compliant receiver must be able to compensate for up to 80 ppm or 200 kHz. The **EM2420** demodulator tolerates up to 300 kHz offset without significant degradation of the receiver performance.

Soft decision is used at the chip level, i.e. the demodulator does not make a decision for each chip, only for each received symbol. De-spreading is performed using

over sampled symbol correlators. Symbol synchronization is achieved by a continuous start of frame delimiter (SFD) search.

When a SFD is detected, data is written to the `RXFIFO` and may be read out by the microcontroller at a lower bit rate than the 250 kbps generated by the receiver.

The **EM2420** demodulator also handles symbol rate errors in excess of 120 ppm without performance degradation. Resynchronization is performed continuously to adjust for error in the incoming symbol rate.

The `MDMCTRL1.CORR_THR` control bits should be written to 20 to set the threshold for detecting IEEE 802.15.4 start of frame delimiters.

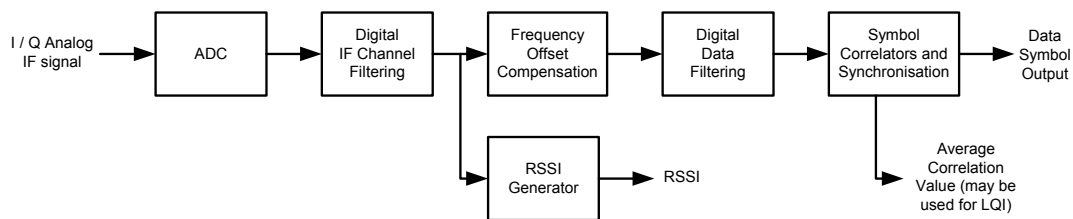

Figure 14. Demodulator Simplified Block Diagram

Frame Format

The **EM2420** has hardware support for parts of the IEEE 802.15.4 frame format. This section gives a brief summary to the IEEE 802.15.4 frame format, and describes how the **EM2420** is set up to comply with this.

Figure 15 [1] shows a schematic view of the IEEE 802.15.4 frame format. Similar figures describing specific frame formats (data frames, beacon frames, acknowledgment frames and MAC command frames) are included in [1].

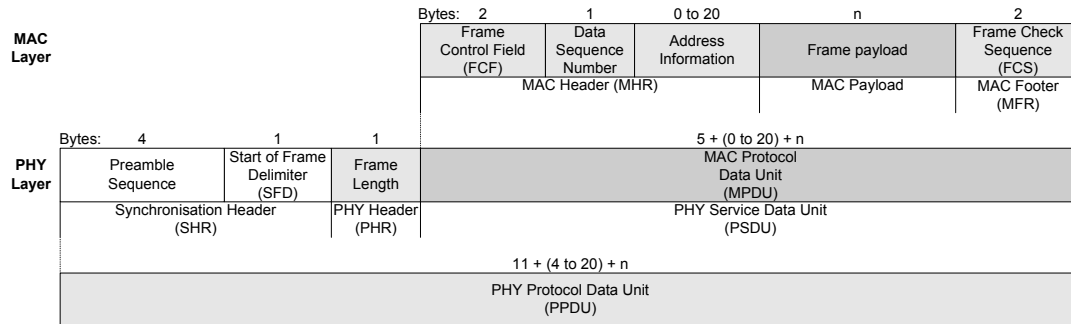

Figure 15. Schematic view of the IEEE 802.15.4 Frame Format [1]

Synchronization header

The synchronisation header (SHR) consists of the preamble sequence followed by the start of frame delimiter (SFD). In [1], the preamble sequence is defined to be 4 bytes of 0x00. The SFD is one byte, set to 0xA7.

In the **EM2420**, the preamble length and SFD is configurable. The default values are compliant with [1]. Changing these values will make the system non-802.15.4-compliant, which could be desirable in some cases.

A synchronisation header is always transmitted first in all transmit modes.

The preamble sequence length can be set by `MDMCTRL0.PREAMBLE_LENGTH`, while the SFD is programmed in the `SYNCWORD` register. `SYNCWORD` is 2 bytes long, which gives the user some extra flexibility as described below. Figure 16 shows how the **EM2420** synchronisation header relates to the IEEE 802.15.4 specification.

The programmable preamble length only applies to transmission, it does not affect

receive mode. The preamble length should not be set shorter than the default value. Note that 2 of the 8 zero-symbols in the preamble sequence required by [1] are included in the `SYNCWORD` register so that the **EM2420** preamble sequence is only 6 symbols long for compliance with [1]. Two additional zero symbols in `SYNCWORD` make the **EM2420** compliant with [1].

In reception, the **EM2420** synchronizes to received zero-symbols and searches for the SFD sequence defined by the `SYNCWORD` register. The least significant symbols in `SYNCWORD` set to 0xF will be ignored, while symbols different from 0xF will be required for synchronisation. The default setting of 0xA70F thereby requires one additional zero-symbol for synchronisation. This will reduce the number of false frames detected due to noise.

In receive mode, the **EM2420** uses the preamble sequence for symbol synchronisation and frequency offset adjustments. The SFD is used for byte synchronisation, and is not part of the data stored in the receive buffer (RXFIFO).

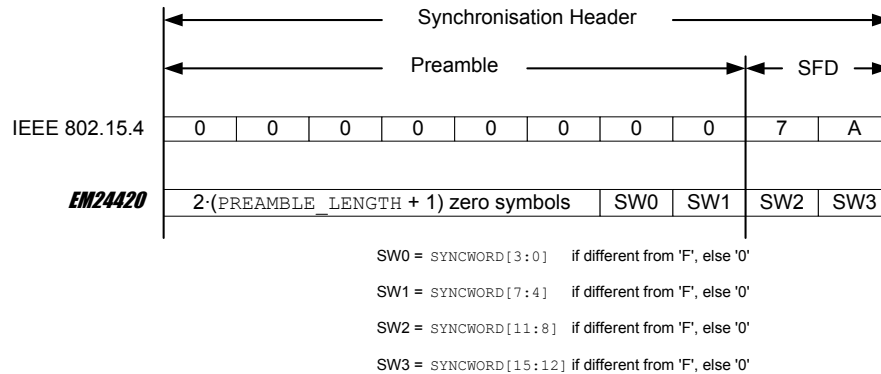

Figure 16. Transmitted Synchronization Header

Length field

The frame length field shown in Figure 15 defines the number of bytes in the MPDU. Note that the length field does not include the length field itself. It does however include the FCS (Frame Check Sequence), even if this is inserted automatically by the **EM2420** hardware. It also includes the MIC if authentication is used.

The length field is 7 bits and has a maximum value of 127. The most significant bit in the length field is reserved [1], and should be set to zero.

The **EM2420** hardware uses the length field both for transmission and reception, so this field must always be included even if implementing a proprietary (non 802.15-4) system.

In transmit mode, the length field is used for underflow detection, as described in the FIFO access section on page 29.

MAC protocol data unit

The FCF, data sequence number and address information follows the length field as shown in Figure 15. Together with the MAC data payload and Frame Check Sequence, they form the MAC Protocol Data Unit (MPDU).

The format of the FCF is shown in Figure 17. Please refer to [1] for details.

There is no hardware support for the data sequence number, this field must be inserted and verified by software.

The **EM2420** includes hardware address recognition, as described in the Address Recognition section on page 39.

Bits: 0-2	3	4	5	6	7-9	10-11	12-13	14-15
Frame Type	Security Enabled	Frame Pending	Acknowledge request	Intra PAN	Reserved	Destination addressing mode	Reserved	Source addressing mode

Figure 17. Format of the Frame Control Field (FCF) [1]

Frame check sequence

A 2-byte frame check sequence (FCS) follows the last MAC payload byte as shown in Figure 15. The FCS is calculated over the MPDU, i.e. the length field is not part of the FCS. This field is automatically

generated and verified by hardware when the `MODEMCTRL0.AUTOCRC` control bit is set. It is recommended to always have this enabled, except possibly for debug purposes. If cleared, CRC generation and verification must be performed by software.

The FCS polynomial is [1]:

$$x^{16} + x^{12} + x^5 + 1$$

The **EM2420** hardware implementation is shown in Figure 18. Please refer to [1] for further details.

In transmit mode the FCS is appended at the correct position defined by the length field. The FCS is not written to the TXFIFO, but stored in a separate 16-bit register.

In receive mode the FCS is verified by hardware. The user is normally only interested in the correctness of the FCS, not the FCS sequence itself. The FCS sequence itself is therefore not written to the RXFIFO during receive.

Instead, when `MODEMCTRL0.AUTOCRC` is set the two FCS bytes are replaced by the RSSI value, average correlation value (used for LQI) and CRC OK/not OK. This is illustrated in Figure 19.

The first FCS byte is replaced by the 8-bit RSSI value. See the RSSI section on page 48 for details.

The 7 least significant bits in the last FCS byte are replaced by the average correlation value of the 8 first symbols of the received PHY header (length field) and PHY Service Data Unit (PSDU). This correlation value may be used as a basis for calculating the LQI. See the

Link Quality Indication section on page 49 for details.

The most significant bit in the last byte of each frame is set high if the CRC of the received frame is correct and low otherwise.

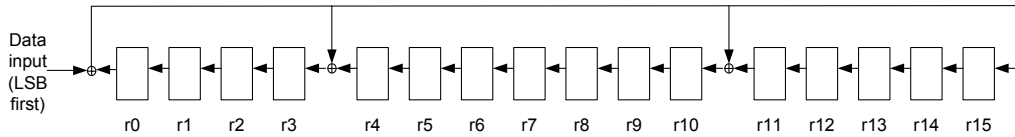

Figure 18. The EM2420 Frame Check Sequence (FCS) hardware implementation [1]

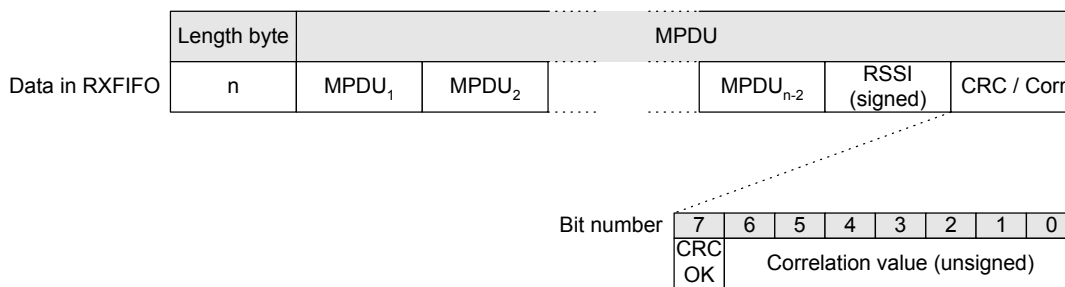

Figure 19. Data in RXFIFO when MDMCTRL0.AUTOCRC is set

RF Data Buffering

The **EM2420** can be configured for different transmit and receive modes, as set in the `MDMCTRL1.TX_MODE` and `MDMCTRL1.RX_MODE` control bits. Buffered mode (mode 0) will be used for normal operation of the **EM2420**, while other modes are available for test purposes.

Buffered transmit mode

In buffered transmit mode (`TX_MODE 0`), the 128 byte TXFIFO, located in the **EM2420** RAM, is used to buffer data before transmission. A preamble sequence (defined in the Frame Format section below) is automatically inserted before the length field during transmission. The length field must always be the first byte written to the transmit buffer for all frames.

Writing one or multiple bytes to the TXFIFO is described in the FIFO access section on page 29. Reading data from the TXFIFO is possible with RAM access, but

this does not remove the byte from the FIFO.

Transmission is enabled by issuing a `STXON` or `STXONCCA` command strobe. See the Radio control state machine section on page 42 for an illustration of how the transmit command strobes affect the state of the **EM2420**. The `STXONCCA` strobe is ignored if the channel is busy. See the

Clear Channel Assessment section on page 50 for details on CCA.

The preamble sequence is started 12 symbol periods after the command strobe. After the programmable start of frame delimiter has been transmitted, data is fetched from the TXFIFO.

A TXFIFO underflow is issued if too few bytes are written to the TXFIFO. Transmission is then automatically stopped. The underflow is indicated in the TX_UNDERFLOW status bit, which is returned during each address byte and each byte written to the TXFIFO. The underflow bit is only cleared by issuing a SFLUSHTX command strobe.

The TXFIFO can only contain one data frame at a given time.

After complete transmission of a data frame, the TXFIFO is automatically refilled with the last transmitted frame. Issuing a new STXON or STXONCCA command strobe will then cause the EM2420 to retransmit the last frame.

Writing to the TXFIFO after a frame has been transmitted will cause the TXFIFO to be automatically flushed before the new byte is written. The only exception is if a TXFIFO underflow has occurred, when a SFLUSHTX command strobe is required.

Buffered receive mode

In buffered receive mode (RX_MODE 0), the 128 byte RXFIFO, located in the EM2420 RAM, is used to buffer data received by the demodulator. Accessing data in the RXFIFO is described in the FIFO access section on page 29.

The FIFO and FIFOP pins are used to assist the microcontroller in supervising the RXFIFO. Please note that the FIFO and FIFOP pins are only related to the RXFIFO, even if the EM2420 is in transmit mode.

Multiple data frames may be in the RXFIFO simultaneously, as long as the total number of bytes does not exceed 128.

See the RXFIFO overflow section on page 31 for details on how a RXFIFO overflow is detected and signaled.

Unbuffered, serial mode

Unbuffered mode should be used for evaluation / debugging purposes only. Buffered mode is recommended for all applications.

In un-buffered mode, the FIFO and FIFOP pins are reconfigured as data and data clock pins. The TXFIFO and RXFIFO buffers are not used in this mode. A synchronous data clock is provided by the EM2420 at the FIFOP pin, and the FIFO pin is used as data input/output. The FIFOP clock frequency is 250 kHz when active. This is illustrated in Figure 20.

In serial transmit mode (MDMCTRL1.TX_MODE=1), a synchronization sequence is inserted at the start of each frame by hardware, as in buffered mode. Data is sampled by the EM2420 on the positive edge of FIFOP and should be updated by the microcontroller on the negative edge of FIFOP. See Figure 20 for an illustration of the timing in serial transmit mode. The SFD and CCA pins retain their normal operation also in serial mode. The EM2420 will remain in serial transmit mode until transmission is turned off manually.

In serial receive mode (MDMCTRL1.RX_MODE=1) byte synchronization is still performed by the EM2420. This means that the FIFOP clock pin will remain idle low until a start of frame delimiter has been detected.

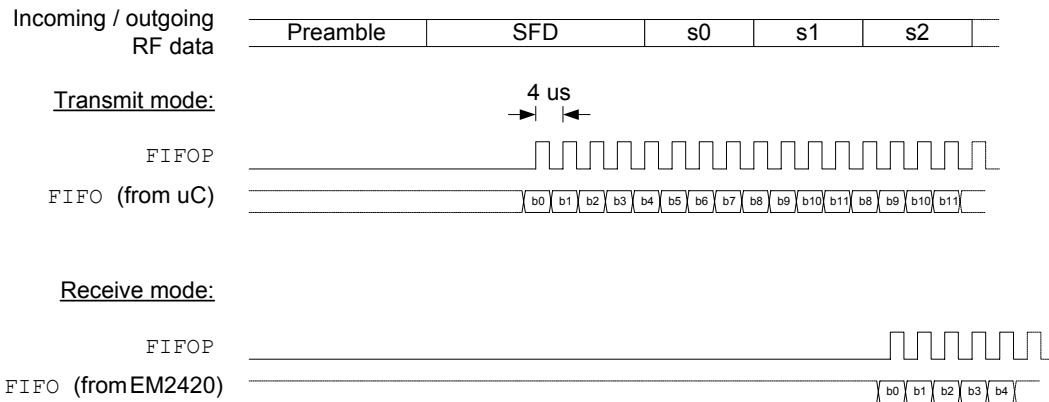

Figure 20. Unbuffered test mode, pin activity

Address Recognition

The **EM2420** includes hardware support for address recognition, as specified in [1]. Hardware address recognition may be enabled / disabled using the `MDMCTRL0.ADR_DECODE` control bit.

Address recognition is based on the following requirements, listed from section 7.5.6.2 in [1]:

- The frame type subfield shall not contain an illegal frame type
- If the frame type indicates that the frame is a beacon frame, the source PAN identifier shall match `macPANId` unless `macPANId` is equal to `0xFFFF`, in which case the beacon frame shall be accepted regardless of the source PAN identifier.
- If a destination PAN identifier is included in the frame, it shall match `macPANId` or shall be the broadcast PAN identifier (`0xFFFF`).
- If a short destination address is included in the frame, it shall match either `macShortAddress` or the broadcast address (`0xFFFF`). Otherwise if an extended destination address is included in the frame, it shall match `aExtendedAddress`.

- If only source addressing fields are included in a data or MAC command frame, the frame shall only be accepted if the device is a PAN coordinator and the source PAN identifier matches `macPANId`.

If any of the above requirements are not satisfied and address recognition is enabled, the **EM2420** will disregard the incoming frame and flush the data from the RXFIFO. Only data from the rejected frame is flushed, data from previously accepted frames may still be in the RXFIFO.

Incoming frames with reserved frame types (FCF frame type subfield is 4, 5, 6 or 7) is however accepted if the `RESERVED_FRAME_MODE` control bit in `MDMCTRL0` is set. In this case, no further address recognition is performed on these frames. This option is included for future expansions of the IEEE 802.15.4 standard.

If a frame is rejected, the **EM2420** will only start searching for a new frame after the rejected frame has been completely received (as defined by the length field) to avoid detecting false SFDs within the frame.

The `MDMCTRL0.PAN_COORDINATOR` control bit must be correctly set, since parts of the address recognition procedure

requires knowledge about whether the

current device is a PAN coordinator or not.

Acknowledge Frames

The **EM2420** includes hardware support for transmitting acknowledge frames, as specified in [1]. Figure 21 shows the format of the acknowledge frame.

If `MDMCTRL0.AUTOACK` is enabled, an acknowledge frame is transmitted for all incoming frames accepted by the address recognition with the acknowledge request flag set and a valid CRC. `AUTOACK` therefore does not make sense unless

also `ADR_DECODE` and `AUTOCRC` are enabled. The sequence number is copied from the incoming frame.

`AUTOACK` may be used for non-beacon systems as long as the frame pending field (see Figure 17) is cleared. The acknowledge frame is then transmitted 12 symbol periods after the last symbol of the incoming frame. This is as specified by [1] for non-beacon networks.

Bytes: 4	1	1	2	1	2
Preamble Sequence	Start of Frame Delimiter (SFD)	Frame Length	Frame Control Field (FCF)	Data Sequence Number	Frame Check Sequence (FCS)
Synchronisation Header (SHR)		PHY Header (PHR)	MAC Header (MHR)		MAC Footer (MFR)

Figure 21. Acknowledge frame format [1]

Two command strobes, `SACK` and `SACKPEND` are defined to transmit acknowledge frames with the frame pending field cleared or set, respectively. The acknowledge frame is only transmitted if the CRC is valid.

For systems using beacons, there is an additional timing requirement that the acknowledge frame transmission should be started on the first backoff-slot boundary (20 symbol periods) at least 12 symbol periods after the last symbol of the incoming frame. This timing must be controlled by the microcontroller by issuing the `SACK` and `SACKPEND` command strobe 12 symbol periods before the following backoff-slot boundary, as illustrated in Figure 22.

If a `SACK` or `SACKPEND` command strobe is issued while receiving an incoming frame, the acknowledge frame is transmitted 12 symbol periods after the last symbol of the incoming frame. This should be used to transmit acknowledge frames in non-beacon networks. This timing is also illustrated in Figure 22.

Using `SACKPEND` will set the pending data flag for automatically transmitted acknowledge frames using `AUTOACK`. The pending flag will then be set also for future acknowledge frames, until a `SACK` command strobe is issued.

Acknowledge frames may be manually transmitted using normal data transmission if desired.

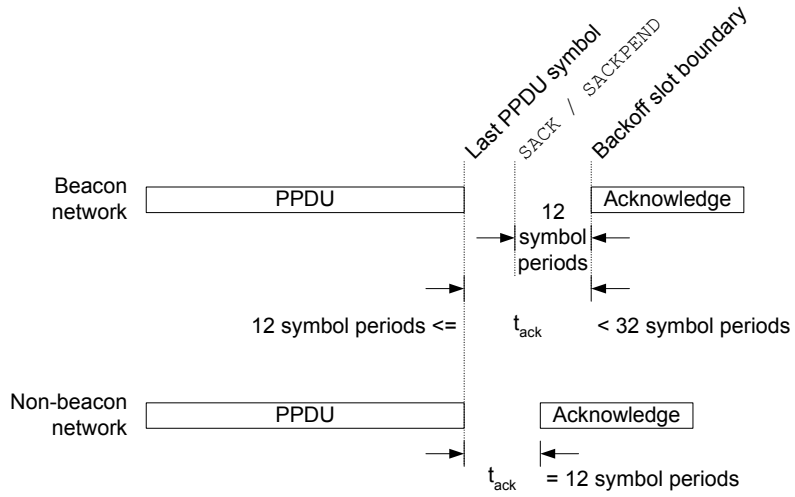

Figure 22. Acknowledge frame timing

Radio control state machine

The **EM2420** has a built-in state machine that is used to switch between different operation states (modes). The change of state is done either by using command strobes or by internal events such as SFD detected in receive mode.

The radio control state machine states are shown in Figure 23. The numbers in brackets refer to the state number readable in the `FSMSTATE` status register. This functionality is primarily for test / debug purposes.

Before using the radio in either RX or TX mode, the voltage regulator and crystal oscillator must be turned on and become stable. The voltage regulator and crystal oscillator startup times are given in the Electrical Specifications section on page 9.

The crystal oscillator is controlled by accessing the `SXOSCON` / `SXOSCOFF` command strobes. The `XOSC16M_STABLE` bit in the status register returned during address transfer indicates whether the oscillator is running and stable or not (see Table 5). This status register can be polled when waiting for the oscillator to start.

For test purposes, the frequency synthesizer (FS) can also be manually calibrated and started by using the `STXCAL` command strobe register. This will not start a transmission before a `STXON` command strobe is issued. This is not shown in Figure 23.

Enabling transmission is done by issuing a `STXON` or `STXONCCA` command strobe.

Turning off RF can be accomplished by using one of the `SRFOFF` or `SXOSCOFF` command strobe registers.

After reset, the **EM2420** is in Power Down mode. All configuration registers can then be programmed in order to make the chip ready to operate at the correct frequency and mode. Due to the very fast start-up time, the **EM2420** can remain in Power Down until a transmission session is requested.

As also described in the 4-wire Serial Configuration and Data Interface section on page 25, the crystal oscillator must be running in order to have access to the RAM and FIFOs.

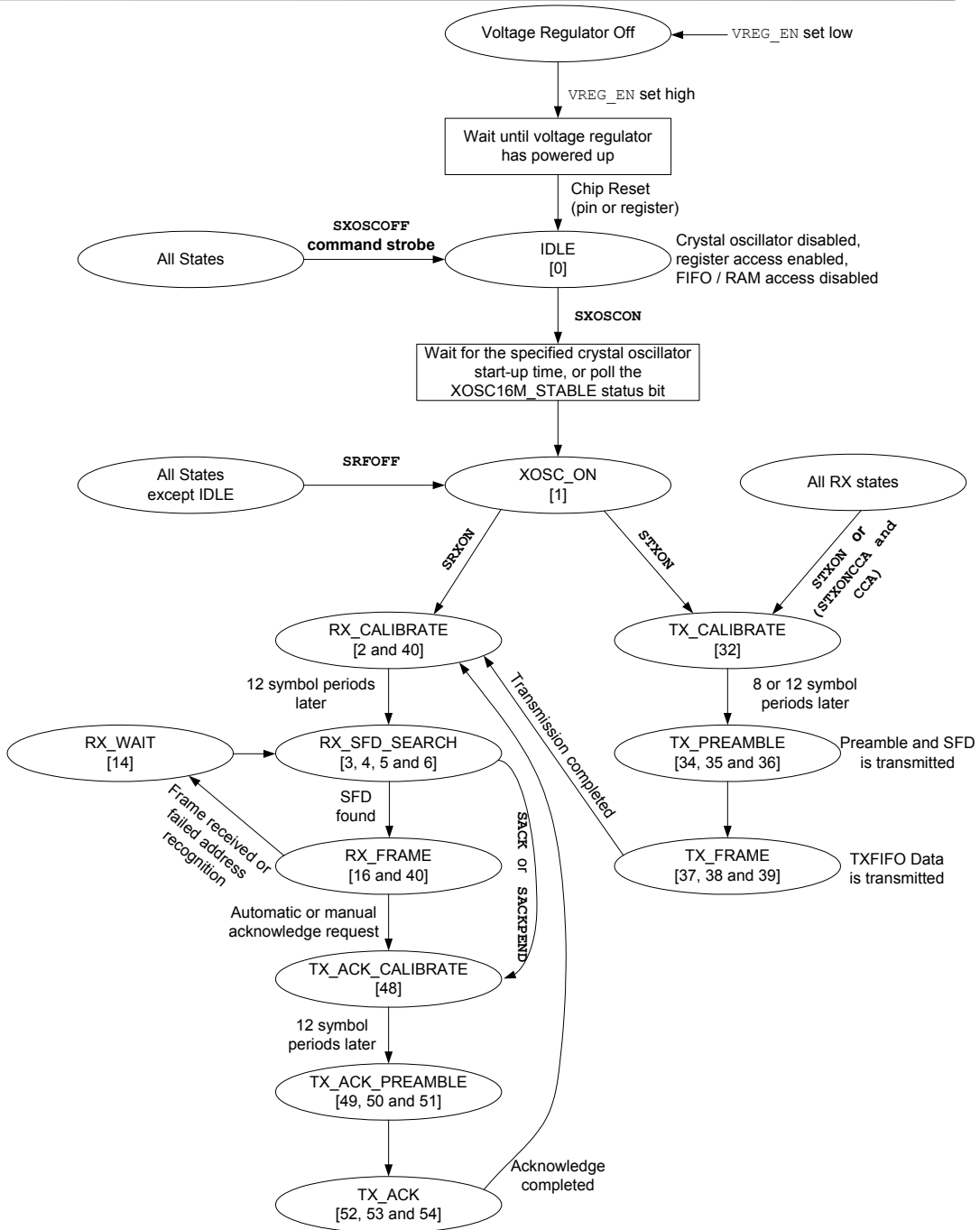

Figure 23. Radio control states

MAC Security Operations (Encryption and Authentication)

The EM2420 features hardware IEEE 802.15.4 MAC security operations, which are exposed in the EmberNet API. This includes counter mode (CTR) encryption / decryption, CBC-MAC authentication and CCM encryption + authentication. All security operations are based on AES encryption [2] using 128 bit keys. Security operations are performed within the transmit and receive FIFOs on a frame basis.

The **EM2420** also includes stand-alone AES encryption, in which one 128 bit plaintext is encrypted to a 128 bit ciphertext.

The SAES, STXENC and SRXDEC command strobes are used to start security operations in the **EM2420** as will be described in the following sections. The ENC_BUSY status bit (see Table 5) may be used to monitor when a security operation has been completed. Security command strobes issued while the security engine is busy will be ignored, and the ongoing operation will be completed.

Table 6 on page 29 shows the **EM2420** RAM memory map, including the security related data located from addresses 0x100 through 0x15F. RAM access (see the RAM access section on page 27) is used to write or read the keys, nonces, and stand-alone buffer. All security related data is stored little-endian, i.e. the least significant byte is transferred first over the SPI interface during RAM read or write operations.

For a complete description of IEEE 802.15.4 MAC security operations, please refer to [1].

Keys

All security operations are based on 128 bit keys. The **EM2420** RAM space has storage space for two individual keys (KEY0 and KEY1). Transmit, receive and stand-alone encryption may select one of these two keys individually in the SEC_TXKEYSEL, SEC_RXKEYSEL and SEC_SAKKEYSEL control bits (SECCTRL0).

As can be seen from Table 6 on page 29, KEY0 is located from address 0x100 and KEY1 from address 0x130.

A way of establishing the keys used for encryption and authentication must be decided for each particular application. IEEE 802.15.4 does not define how this is done; it is left to the higher layer of the protocol.

ZigBee uses an Elliptic Curve Cryptography (ECC) based approach to establish keys. For PC based solutions, more processor intensive solutions such as Diffie-Hellman may be chosen. Some applications may also use pre-programmed keys, e.g. for remote keyless entry where the key and lock are delivered in pairs. A push-button approach for loading keys may also be selected.

Nonce / counter

The receive and transmit nonces used for encryption / decryption are located in RAM from addresses 0x110 and 0x140 respectively. They are both 16 bytes.

The nonce must be correctly initialized before receive or transmit CTR or CCM operations are started. The format of the nonce is shown in Table 7. The block counter must be set to 1 for compliance with [1]. The key sequence counter is controlled by a layer above the MAC layer. The frame counter must be increased for each new frame by the MAC layer. The source address is the 64 bit IEEE address.

1 byte	8 bytes	4 bytes	1 byte	2 bytes
Flags	Source Address	Frame Counter	Key Sequence Counter	Block Counter

Table 7. IEEE 802.15.4 Nonce [1]

The block counter bytes are not updated in RAM, only in a local copy which is reloaded for each new in-line security operation. I.e. the block counter part of the nonce does not need to be rewritten. The **EM2420** block counter should be set to 0x0001 for compliance with [1].

The **EM2420** gives the user full flexibility in selecting the flags for both nonces. The flag setting is stored in the most significant byte of the nonce. The flag byte used for encryption and authentication is then generated as shown in Figure 24.

The frame counter part of the nonce must be incremented for each new packet by software.

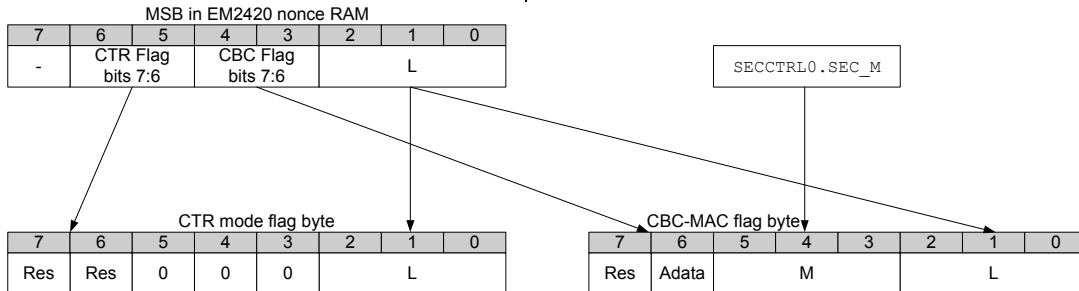

Figure 24. The EM2420 Security Flag Byte

Stand-alone encryption

Plain AES encryption, with 128 bit plaintext and 128 bit keys [2], is available using stand-alone encryption. The plaintext is stored in stand-alone buffer located at RAM location 0x120, as can be seen from Table 6 on page 29.

A stand-alone encryption operation is initiated by using the SAES command strobe. The selected key (SECCTRL0.SEC_SAKYSEL) is then used to encrypt the plaintext written to the stand-alone buffer. Upon completion of the encryption operation, the ciphertext is written back to the stand-alone buffer, thereby overwriting the plaintext.

Note that RAM write operations also output data currently in RAM, so that a new plaintext may be written at the same time as reading out the previous ciphertext.

In-line security operations

The **EM2420** can do MAC security operations (encryption, decryption and authentication) on frames within the TXFIFO and RXFIFO. These operations are called in-line security operations.

As with other MAC hardware support within the **EM2420**, in-line security operation relies on the length field in the PHY header. A correct length field must

therefore be used for all security operations.

The key, nonce (does not apply to CBC-MAC), and SECCTRL0 and SECCTRL1 control registers must be correctly set before starting any in-line security operation.

The in-line security mode is set in SECCTRL0.SEC_MODE to one of the following modes:

- Disabled
- CBC-MAC (authentication)
- CTR (encryption / decryption)
- CCM (authentication and encryption / decryption)

When enabled, TX in-line security is started in one of two ways:

- Issue a STXENC command strobe. In-line security will be performed within the TXFIFO, but a RF transmission will not be started. Ciphertext may be read back using RAM read operations.
- Issue a STXON or STXONCCA command strobe. In-line security will be performed within the TXFIFO and a RF transmission of the ciphertext is started.

When enabled, RX in-line security is started as follows:

- Issue a `SRXDEC` command strobe. The first frame in the RXFIFO is then decrypted / authenticated as set by the current security mode.

RX in-line security operations are always performed on the first frame currently inside the RXFIFO, even if part of this has already been read out over the SPI interface. This allows the receiver to first read the source address out to decide which key to use before doing authentication of the complete frame. In CTR or CCM mode it is of course important that bytes to be decrypted are not read out before the security operation is started.

When the `SRXDEC` command strobe is issued, the `FIFO` and `FIFOP` pins will go low. This is to indicate to the microcontroller that no further data may be read out before the next byte to be read has undergone the requested security operation.

The frame in the RXFIFO may be received over RF or it may be written into the RXFIFO over the SPI interface for debugging or higher layer security operations.

CTR mode encryption / decryption

CTR mode encryption / decryption is performed by the **EM2420** on MAC frames within the TXFIFO / RXFIFO respectively.

`SECCTRL1.SEC_TXL / SEC_RXL` sets the number of bytes between the length field and the first byte to be encrypted / decrypted respectively. This controls the number of plaintext bytes in the current frame. For IEEE 802.15.4 MAC encryption, only the MAC payload (see Figure 15 on page 34) should be encrypted, so `SEC_TXL / SEC_RXL` is set to 3 + (0 to 20) depending on the address information in the current frame.

When encryption is initiated, the plaintext in the TXFIFO is then encrypted as specified by [1]. The encryption module will encrypt all the plaintext currently available, and wait if not everything is prebuffered. The encryption operation may also be started without any data in the

TXFIFO at all, and data will be encrypted as it is written to the TXFIFO.

When decryption is initiated with a `SRXDEC` command strobe, the ciphertext of the RXFIFO is then decrypted as specified by [1].

CBC-MAC

CBC-MAC in-line authentication is provided by the **EM2420** hardware.

`SECCTRL0.SEC_M` sets the MIC length M, encoded as $(M-2)/2$.

When enabling CBC-MAC in-line TXFIFO authentication, the generated MIC is written to the TXFIFO for transmission. The frame length must include the MIC.

`SECCTRL1.SEC_TXL / SEC_RXL` sets the number of bytes between the length field and the first byte to be authenticated, normally set to 0 for MAC authentication.

`SECCTRL0.SEC_CBC_HEAD` defines if the authentication length is used as the first byte of data to be authenticated or not. This bit should be set for compliance with [1].

When enabling CBC-MAC in-line RXFIFO authentication, the generated MIC is compared to the MIC in the RXFIFO. The last byte of the MIC is replaced in the RXFIFO with:

- 0x00 if the MIC is correct
- 0xFF if the MIC is incorrect

The other bytes in the MIC are left unchanged in the RXFIFO.

CCM

CCM combines CTR mode encryption and CBC-MAC authentication in one operation. CCM is described in [3].

`SECCTRL1.SEC_TXL / SEC_RXL` sets the number of bytes after the length field to be authenticated but not encrypted.

The MIC is generated and verified very much like with CBC-MAC described

above. The only differences are from the requirements in [1] for CCM.

Timing

Table 8 shows some examples of the time used by the security module for different operations.

Mode	I(a)	I(m)	I(MIC)	Time [us]
CCM	50	69	8	222
CTR	-	15	-	99
CBC	17	98	12	99
Stand-alone	-	16	-	14

Table 8. Security timing examples

Linear IF and AGC Settings

The **EM2420** is based on a linear IF chain where the signal amplification is done in an analog VGA (variable gain amplifier). The gain of the VGA is digitally controlled.

The AGC (Automatic Gain Control) loop ensures that the ADC operates inside its

dynamic range by using an analog/digital feedback loop.

The AGC characteristics are set through the `AGCTRL`, `AGCTST0`, `AGCTST1` and `AGCTST2` registers. The reset values should be used for all AGC control and test registers.

RSSI / Energy Detection

The **EM2420** has a built-in RSSI (Received Signal Strength Indicator) giving a digital value that can be read from the 8 bit, signed 2's complement `RSSI.RSSI_VAL` register.

The RSSI value is always averaged over 8 symbol periods (128 μ s), in accordance with [1]. The `RSSI_VALID` status bit (Table 5) indicates when the RSSI value is valid, meaning that the receiver has been enabled for at least 8 symbol periods.

The RSSI register value `RSSI.RSSI_VAL` can be referred to the power P at the RF pins by using the following equations:

$$P = \text{RSSI_VAL} + \text{RSSI_OFFSET} \text{ [dBm]}$$

where the `RSSI_OFFSET` is found empirically during system development from the front end gain. `RSSI_OFFSET` is approximately -45. E.g. if reading a value of -20 from the `RSSI` register, the RF input power is approximately -65 dBm.

A typical plot of the `RSSI_VAL` reading as function of input power is shown in Figure 25. It can be seen from the figure that the RSSI reading from the **EM2420** is very linear and has a dynamic range of about 100 dB.

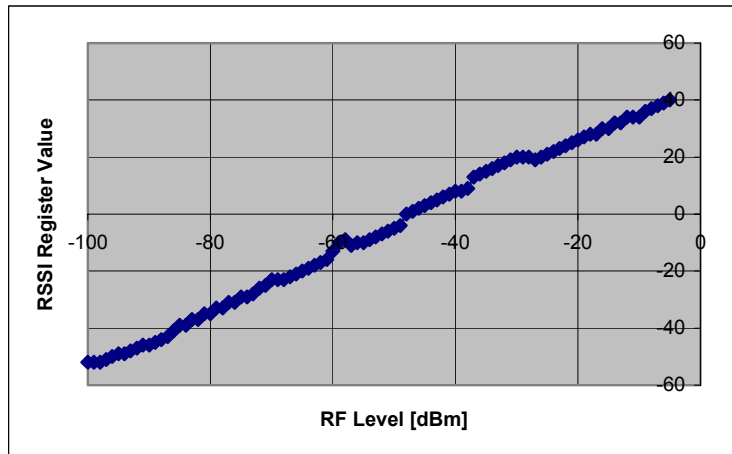

Figure 25. Typical RSSI value vs. input power

Link Quality Indication

The link quality indication (LQI) measurement is a characterization of the strength and/or quality of a received packet, as defined by [1].

The RSSI value described in the previous section may be used by the MAC software to produce the LQI value. The LQI value is required by [1] to be limited to the range 0 through 255, with at least 8 unique values. Software is responsible for generating the appropriate scaling of the LQI value for the given application.

Using the RSSI value directly to calculate the LQI value has the disadvantage that e.g. a narrowband interferer inside the channel bandwidth will increase the LQI value although it actually reduces the true link quality. The **EM2420** therefore also provides an average correlation value for each incoming packet, based on the 8 first symbols following the SFD. This unsigned 7-bit value can be looked upon as a measurement of the “chip error rate,” although the **EM2420** does not do chip decision.

As described in the Frame check sequence section on page 35, the average correlation value for the 8 first symbols is appended to each received frame together with the RSSI and CRC OK/not OK when `MDMCTRL0.AUTOCRC` is set. A correlation value of ~110 indicates a maximum quality frame while a value of ~50 is typically the lowest quality frames detectable by the **EM2420**.

Software must convert the correlation value to the range 0-255 defined by [1], e.g. by calculating:

$$LQI = (CORR - a) \cdot b$$

limited to the range 0-255, where *a* and *b* are found empirically based on PER measurements as a function of the correlation value.

A combination of RSSI and correlation values may also be used to generate the LQI value.

Clear Channel Assessment

The clear channel assessment signal is based on the measured RSSI value and a programmable threshold. The clear channel assessment function is used to implement the CSMA-CA functionality specified in [1]. CCA is valid when the receiver has been enabled for at least 8 symbol periods.

Carrier sense threshold level is programmed by `RSSI.CCA_THR`. The threshold value can be programmed in steps of 1 dB. A CCA hysteresis can also be programmed in the `MDMCTRL0.CCA_HYST` control bits.

All 3 CCA modes specified by [1] are implemented in the **EM2420**. They are set in `MDMCTRL0.CCA_MODE`, as can be seen in the register description. The different modes are:

- 0 Reserved
- 1 Clear channel when received energy is below threshold.
- 2 Clear channel when not receiving valid IEEE 802.15.4 data.
- 3 Clear channel when energy is below threshold and not receiving valid IEEE 802.15.4 data

Clear channel assessment is available on the `CCA` output pin. `CCA` is active high, but the polarity may be changed by setting the `IOCFG0.CCA_POLARITY` control bit.

Implementing CSMA-CA may easiest be done by using the `STXONCCA` command strobe, as described in the Radio control state machine section on page 42. Transmission will then only start if the channel is clear. The `TX_ACTIVE` status bit (see Table 5) may be used to detect the result of the CCA.

Frequency and Channel Programming

The operating frequency is set by programming the 10 bit frequency word located in `FSCTRL.FREQ[9:0]`. The operating frequency F_C in MHz is given by:

$$F_C = 2048 + \text{FSCTRL.FREQ}[9:0] \text{ MHz}$$

In receive mode the actual LO frequency is $F_C - 2$ MHz, since a 2 MHz IF is used. Direct conversion is used for transmission, so here the LO frequency equals F_C . The 2 MHz IF is automatically set by the **EM2420**, so the frequency programming is equal for RX and TX.

IEEE 802.15.4 specifies 16 channels within the 2.4 GHz band, numbered 11 through 26. The RF frequency of channel k is given by [1]:

$$F_C = 2405 + 5(k-11) \text{ MHz}, k=11, 12, \dots, 26$$

For operation in channel k , the `FSCTRL.FREQ` register should therefore be set to:

$$\text{FSCTRL.FREQ} = 357 + 5(k-11)$$

VCO and PLL Self-Calibration

VCO

The VCO is completely integrated and operates at 4800 – 4966 MHz. The VCO frequency is divided by 2 to generate frequencies in the desired band (2400-2483.5 MHz).

PLL self-calibration

The VCO's characteristics will vary with temperature, changes in supply voltages, and the desired operating frequency.

In order to ensure reliable operation the VCO's bias current and tuning range are automatically calibrated every time the RX mode or TX mode is enabled, i.e. in the `RX_CALIBRATE`, `TX_CALIBRATE` and `TX_ACK_CALIBRATE` control states in Figure 23 on page 43.

Output Power Programming

The RF output power of the device is programmable and is controlled by the TXCTRL.PA_LEVEL register. Table 9 shows the output power for different settings, including the complete programming of the TXCTRL control

register. The typical current consumption is also shown.

The power amplifier can be operated in differential mode.

PA_LEVEL	TXCTRL register	Output Power [dBm]	Current Consumption [mA]
31	0xA0FF	0	17.4
27	0xA0FB	-1	16.5
23	0xA0F7	-3	15.2
19	0xA0F3	-5	13.9
15	0xA0EF	-7	12.5
11	0xA0EB	-10	11.2
7	0xA0E7	-15	9.9
3	0xA0E3	-25	8.5

Table 9. Output power settings and typical current consumption @ 2.45 GHz

Voltage Regulator

The **EM2420** includes a low drop-out voltage regulator. This is used to provide a 1.8 V power supply to the **EM2420** power supplies. The voltage regulator should not be used to provide power to other circuits because of limited power sourcing capability and noise considerations.

The voltage regulator input pin `VREG_IN` is connected to the unregulated 2.1 to 3.6 V power supply. The voltage regulator is enabled / disabled using the active high voltage regulator enable pin `VREG_EN`. The regulated 1.8 V voltage output is

available on the `VREG_OUT` pin. A simplified schematic of the voltage regulator is shown in Figure 26.

The voltage regulator requires external components as described in the Application Circuit section on page 18.

When disabling the voltage regulator, note that register and RAM programming will be lost as leakage current reduces the output voltage on the `VREG_OUT` pin below 1.6 V. The **EM2420** should then be reset before the voltage regulator is disabled.

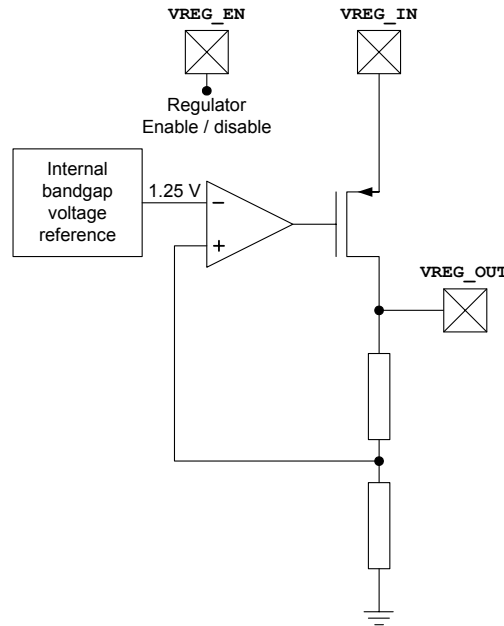

Figure 26. Voltage regulator, simplified schematic

Battery Monitor

The on-chip battery monitor enables monitoring the unregulated voltage on the `VREG_IN` pin. It gives status information on the voltage being above or below a

programmable threshold. A simplified schematic of the battery monitor is shown in Figure 27.

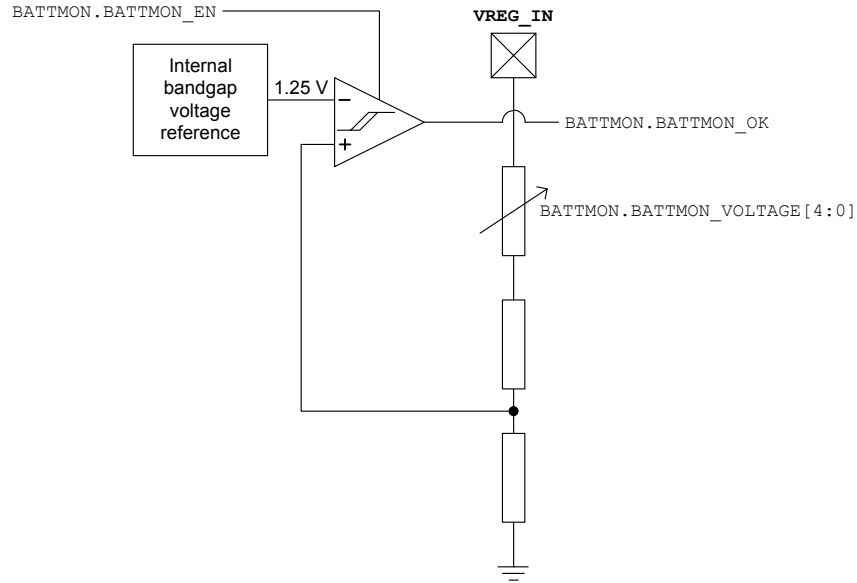

Figure 27. Battery monitor, simplified schematic

The battery monitor is controlled through the `BATTMON` control register. The battery monitor is enabled and disabled using the `BATTMON.BATTMON_EN` control bit. The voltage regulator must also be enabled when using the battery monitor.

The battery monitor status bit is available in the `BATTMON.BATTMON_OK` status bit. This bit is high when the `VREG_IN` input voltage is higher than the toggle voltage V_{toggle} .

The battery monitor toggle voltage is set in the 5-bit `BATTMON.BATTMON_VOLTAGE` control bits. `BATTMON_VOLTAGE` is an unsigned, positive number from 0 to 31. The toggle voltage is given by:

$$V_{toggle} = 1.25 \text{ V} \cdot \frac{72 - \text{BATTMON_VOLTAGE}}{27}$$

Alternatively, for a desired toggle voltage, `BATTMON_VOLTAGE` should be set according to:

$$\text{BATTMON_VOLTAGE} = 72 - 27 \cdot \frac{V_{toggle}}{1.25 \text{ V}}$$

The voltage regulator must be enabled for at least 100 μs before the first measurement. After being enabled, the `BATTMON_OK` status bit need 2 μs to settle for each new toggle voltage programmed.

The main performance characteristics of the battery monitor is shown in the Electrical Specifications section on page 9.

Crystal Oscillator

An external clock signal or the internal crystal oscillator can be used as main frequency reference. The reference frequency must be 16 MHz. Because the crystal frequency is used as reference for the data rate as well as other internal signal processing functions, other frequencies cannot be used.

If an external clock signal is used this should be connected to XOSC16_Q1, while XOSC16_Q2 should be left open. The MAIN.XOSC16M_BYPASS bit must be set when an external clock signal is used.

Using the internal crystal oscillator, the crystal must be connected between the XOSC16_Q1 and XOSC16_Q2 pins. The oscillator is designed for parallel mode operation of the crystal. In addition, loading capacitors (C₃₈₁ and C₃₉₁) for the crystal are required. The loading capacitor values depend on the total load capacitance, C_L, specified for the crystal. The total load capacitance seen between the crystal terminals should equal C_L for the crystal to oscillate at the specified frequency.

$$C_L = \frac{1}{\frac{1}{C_{381}} + \frac{1}{C_{391}}} + C_{parasitic}$$

The parasitic capacitance is constituted by pin input capacitance and PCB stray capacitance. The total parasitic capacitance is typically 5 pF. A trimming capacitor may be placed across C₃₈₁ for initial tuning if necessary.

The crystal oscillator circuit is shown in Figure 28. Typical component values for different values of C_L are given in Table 10.

The crystal oscillator is amplitude regulated. This means that a high current is used to start up the oscillations. When the amplitude builds up, the current is reduced to what is necessary to maintain a stable oscillation. This ensures a fast start-up and keeps the drive level to a minimum. The ESR of the crystal must be within the specification in order to ensure a reliable start-up (see the Electrical Specifications section).

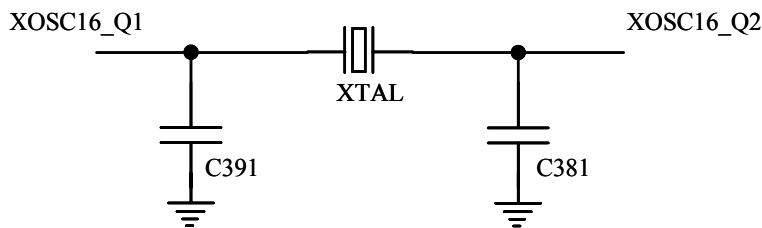

Figure 28. Crystal oscillator circuit

Item	C _L = 12 pF	C _L = 16 pF	C _L = 22 pF
C6	6.8 pF	18 pF	27 pF
C7	6.8 pF	18 pF	27 pF

Table 10. Crystal oscillator component values

Input / Output Matching

The RF input / output is differential (RF_N and RF_P). In addition there is supply switch output pin ($TXRX_SWITCH$) that must have an external DC path to RF_N and RF_P .

In RX mode the $TXRX_SWITCH$ pin is at ground and will bias the LNA. In TX mode the $TXRX_SWITCH$ pin is at supply rail voltage and will properly bias the internal PA.

The RF output and DC bias can be done using different topologies. Some are shown in Figure 3 and Figure 4.

Component values are given in Table 2. Using a differential antenna, no balun is required.

If a single ended output is required (for a single ended connector or a single ended antenna), a balun should be used for optimum performance. The balun can be realized using discrete inductors and capacitors, or a LTCC balun can be used.

Transmitter Test Modes

The **EM2420** can be set into different transmit test modes for performance evaluation. The test mode descriptions in the following sections require that the chip is first reset, the crystal oscillator is enabled using the $SXOSCON$ command strobe and that the crystal oscillator has stabilized.

Unmodulated carrier

An unmodulated carrier may be transmitted by setting $MDMCTRL1.TX_MODE$ to 2, writing 0x1800 to the $DACTST$ register and issue a $STXON$ command strobe. The transmitter is then enabled while the transmitter I/Q DACs are overridden to static values. An

unmodulated carrier will then be available on the RF output pins.

A plot of the single carrier output spectrum from the **EM2420** is shown in Figure 29 below.

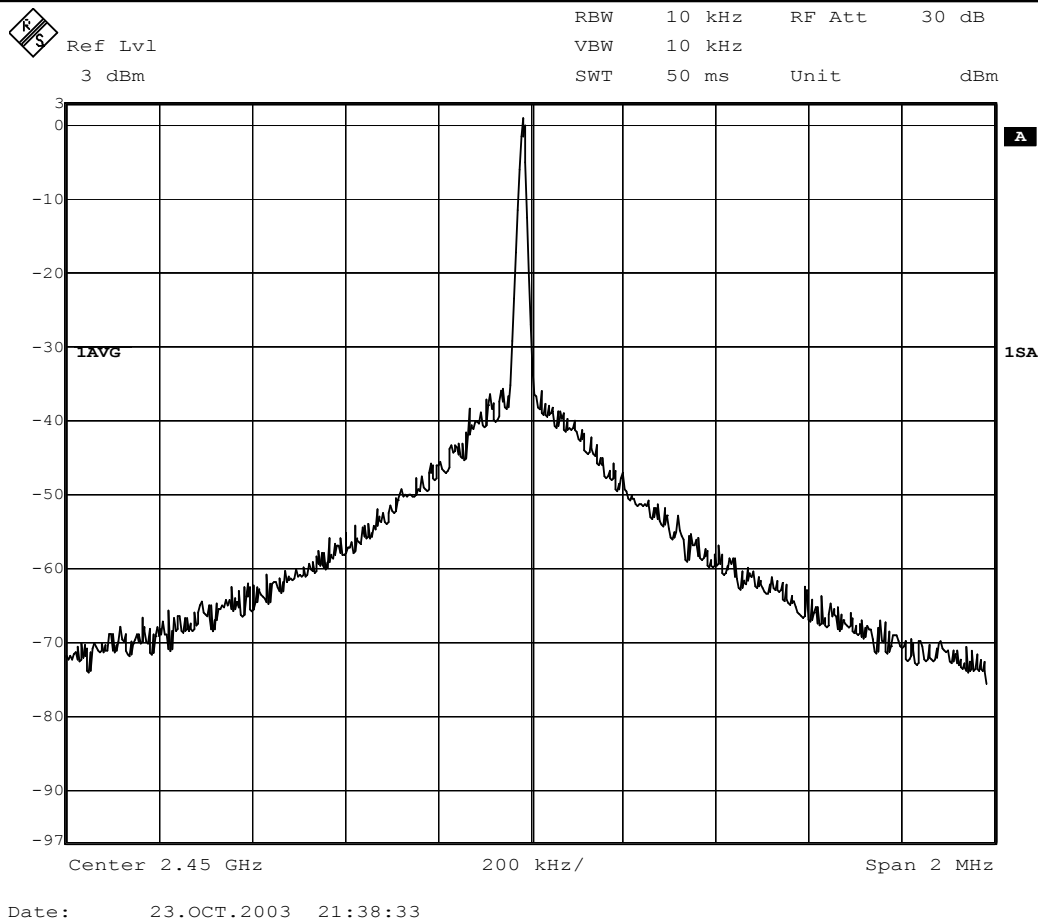

Figure 29. Single carrier output

Modulated spectrum

The **EM2420** has a built-in test pattern generator that can generate pseudo random sequence using the CRC generator. This is enabled by setting `MDMCTRL1.TX_MODE` to 3 and issuing a `STXON` command strobe. The modulated spectrum is then available on the RF pins. The low byte of the CRC word is transmitted and the CRC is updated with 0xFF for each new byte. The length of the transmitted data sequence is 65535 bits. The transmitted data-sequence is then:

[synchronization header] [0x00, 0x78, 0xb8, 0x4b, 0x99, 0xc3, 0xe9, ...]

Since a synchronization header (preamble and SFD) is transmitted in all TX modes, this test mode may also be used to transmit a known pseudorandom bit

sequence for bit error testing. Please note that the **EM2420** requires symbol synchronization, not only bit synchronization, for correct reception. Packet error rate is therefore a better measurement for the true RF performance.

Another option to generate a modulated spectrum is to fill the TXFIFO with pseudo-random data and set `MDMCTRL1.TX_MODE` to 3. The **EM2420** will then transmit data from the FIFO disregarding a TXFIFO underflow. The length of the transmitted data sequence is then 1024 bits (128 bytes).

A plot of the modulated spectrum from the **EM2420** is shown in Figure 30. Note that to find the output power from the modulated spectrum, the RBW must be set to 3 MHz or higher.

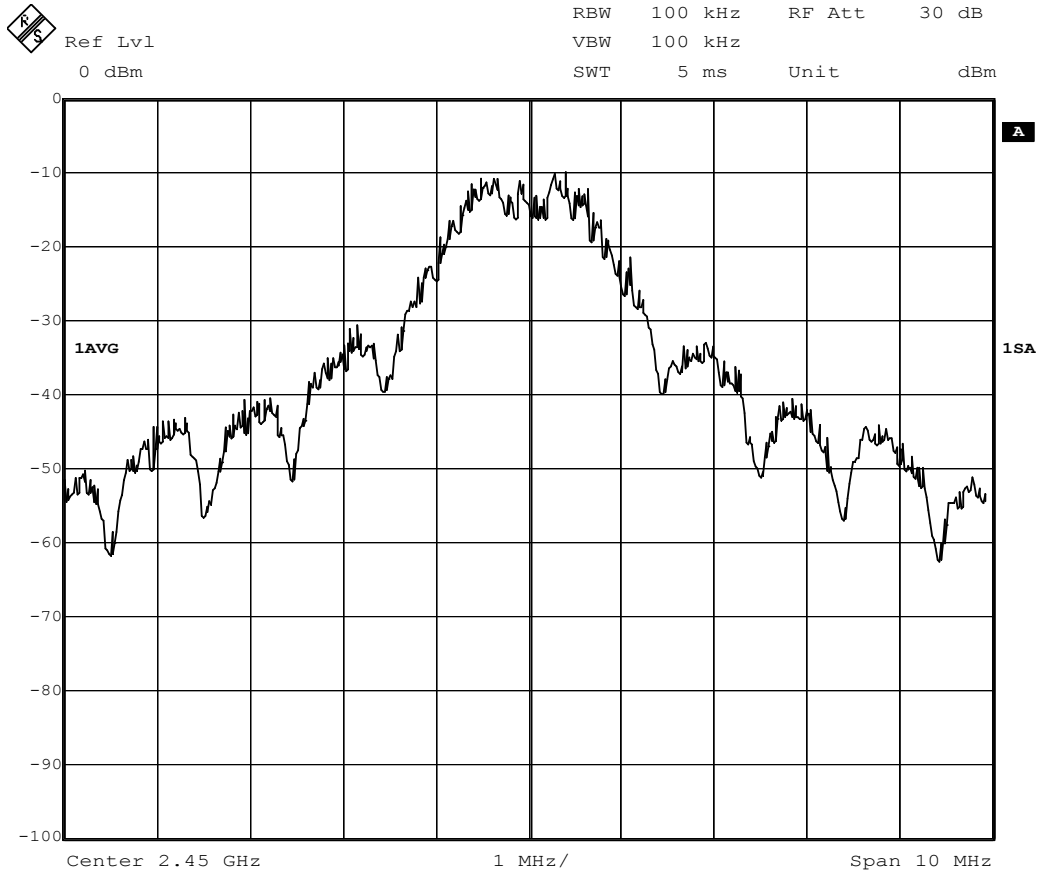

Date: 23.OCT.2003 21:34:19

Figure 30. Modulated spectrum plot

System Considerations and Guidelines

SRD regulations

International regulations and national laws regulate the use of radio receivers and transmitters. SRDs (Short Range Devices) for license free operation are allowed to operate in the 2.4 GHz band worldwide. The most important regulations are EN 300 440 (Europe), FCC CFR-47 part 15.247 and 15.249 (USA), and ARIB STD-T-66 (Japan).

Frequency hopping and multi-channel systems

The 2.4 GHz band is shared by many systems both in industrial, office and home environments. The **EM2420** uses direct sequence spread spectrum (DSSS) as defined by [1] to spread the output power, thereby making the communication link more robust even in a noisy environment.

With the **EM2420** it is also possible to combine both DSSS and FHSS (frequency hopping spread spectrum) in a proprietary non-IEEE 802.15.4 system. This is achieved by reprogramming the operating frequency (see the Frequency and Channel Programming section on page 51) before enabling RX or TX. A frequency synchronization scheme must then be implemented within the proprietary MAC layer to make the transmitter and receiver operate on the same RF channel.

Data burst transmissions

The data buffering in the **EM2420** lets the user have a lower data rate link between the microcontroller and the RF device than the RF bit rate of 250 kbps. This allows the microcontroller to buffer data at its own speed, reducing the workload and timing requirements.

The relatively high data rate of the **EM2420** also reduces the average power consumption compared to the 868 / 915 MHz bands defined by [1], where only 20 / 40 kbps are available. The **EM2420** may be powered up a smaller portion of the time, so that the average power consumption is

reduced for a given amount of data to be transferred.

Crystal accuracy and drift

A crystal accuracy of ± 40 ppm is required for compliance with IEEE 802.15.4 [1]. This accuracy must also take ageing and temperature drift into consideration.

A crystal with low temperature drift and low aging could be used without further compensation. A trimmer capacitor in the crystal oscillator circuit (in parallel with C7) could be used to set the initial frequency accurately.

For non-IEEE 802.15.4 systems, the robust demodulator in the **EM2420** allows up to 120 ppm total frequency offset between the transmitter and receiver. This could e.g. relax the accuracy requirement to 60 ppm for each of the devices.

Optionally in a star network topology, the FFD could be equipped with a more accurate crystal thereby relaxing the requirement on the RFD. This can make sense in systems where the RFDs ship in higher volumes than the FFDs.

Communication robustness

The **EM2420** provides very good adjacent, alternate and co channel rejection, image frequency suppression and blocking properties. The **EM2420** performance is significantly better than the requirements imposed by [1]. These are highly important parameters for reliable operation in the 2.4 GHz band, since an increasing number of devices/systems are using this license free frequency band.

Communication security

The hardware encryption and authentication operations in the **EM2420** enable secure communication, which is required for many applications. Security operations require a lot of data processing which is costly in an 8-bit microcontroller system. The hardware support within the

EM2420 enables a high level of security even with a low-cost 8 bit controller.

Low cost systems

As the **EM2420** provides 250 kbps multi-channel performance without any external filters, a very low cost system can be made.

A differential antenna will eliminate the need for a balun, and the DC biasing can be achieved in the antenna topology.

Battery operated systems

In low power applications, the **EM2420** should be powered down when not being active. Extremely low power consumption may be achieved when disabling also the voltage regulator. This will require reprogramming of the register and RAM configuration.

BER / PER measurements

The **EM2420** includes test modes where data is received infinitely and output to pins (`RX_MODE 2`, see page 38). This mode may be used for Bit Error Rate (BER) measurements. However, the following actions must be taken to do such a measurement:

- A preamble and SFD sequence must be used, even if pseudo random data is transmitted, since receiving the DSSS modulated signal requires *symbol* synchronization, not *bit* synchronization like e.g. in 2FSK systems. The `SYNCWORD` may be set to another value to fit to the measurement setup if necessary.
- The data transmitted over air must be spread according to [1] and the description on page 22. This means that the transmitter used during measurements must be able to do spreading of the bit data to chip data. Remember that the *chip* sequence transmitted by the test setup is not the same as the *bit* sequence which is output by the **EM2420**.

- When operating at or below the sensitivity limit, the **EM2420** may lose symbol synchronization in infinite receive mode. A new SFD and restart of the receiver may be required to re-gain synchronization.

In an IEEE 802.15.4 system, all communication is based on packets. The sensitivity limit specified by [1] is based on Packet Error Rate (PER) measurements instead of BER. This is a more accurate measurement of the true RF performance since it mirrors the way the actual system operates.

Ember recommends performing PER measurements instead of BER measurements to evaluate the performance of IEEE 802.15.4 systems. To do PER measurements, the following may be used as a guideline:

- A valid preamble, SFD and length field must be used for each packet.
- The PSDU (see Figure 15 on page 34) length should be 20 bytes for sensitivity measurements as specified by [1].
- The sensitivity limit specified by [1] is the RF level resulting in a 1% PER. The packet sample space for a given measurement must then be $\gg 100$ to have a sufficiently large sample space. E.g. at least 1000 packets should be used to measure the sensitivity.
- The data transmitted over air must be spread according to [1] and the description on page 22. Pre-generated packets may be used, although [1] requires that the PER is averaged over random PSDU data.
- The **EM2420** receive FIFO may be used to buffer data received during PER measurements, since it is able to buffer up to 128 bytes.
- The `MDMCTRL1.CORR_THR` control register should be set to

20, as described in the Demodulator, Symbol Synchronizer and Data Decision section.

The simplest way of making a PER measurement will be to use another **EM2420** as the reference transmitter. However, this makes it difficult to measure the exact receiver performance.

Using a signal generator, this may either be set up as O-QPSK with half-sine shaping or as MSK. If using O-QPSK, the phases must be selected according to [1]. If using MSK, the chip sequence must be

modified such that the modulated MSK signal has the same phase shifts as the O-QPSK sequence previously defined.

For a desired symbol sequence s_0, s_1, \dots, s_{n-1} of length n symbols, the desired chip sequence $c_0, c_1, c_2, \dots, c_{32n-1}$ of length $32n$ is found using table lookup from Table 3 on page 22. It can be seen from comparing the phase shifts of the O-QPSK signal with the frequency of a MSK signal that the MSK chip sequence is generated as:

$(c_0 \text{ xnor } c_1), (c_1 \text{ xor } c_2), (c_2 \text{ xnor } c_3), \dots, (c_{32n-1} \text{ xor } c_{32n})$ where c_{32n} may be arbitrarily selected.

PCB Layout Recommendations

A four layer PCB is highly recommended. The second layer of the PCB should be the used as a ground plane.

The top layer should be used for signal routing, and the open areas should be filled with metallization connected to ground using several vias.

The area under the chip is used for grounding and must be well connected to the ground plane with several vias.

The ground pins should be connected to ground as close as possible to the package pin using individual vias. The decoupling capacitors should also be placed as close as possible to the supply pins and connected to the ground plane by

separate vias. Supply power filtering is very important.

The external components should be as small as possible (0402 is recommended) and surface mount devices must be used.

Caution should be used when placing the microcontroller in order to avoid interference with the RF circuitry.

A Development Kit with a fully assembled Evaluation Module is available. It is strongly advised that this reference layout is followed very closely in order to get the best performance.

The schematic, BOM and layout Gerber files for the reference designs are all available from the Ember website.

Antenna Considerations

The **EM2420** can be used together with various types of antennas. A differential antenna like a dipole would be the easiest to interface not needing a balun (balanced to un-balanced transformation network).

The length of the $\lambda/2$ -dipole antenna is given by:

$$L = 14250 / f$$

where f is in MHz, giving the length in cm. An antenna for 2450 MHz should be 5.8 cm. Each arm is therefore 2.9 cm.

Other commonly used antennas for short-range communication are monopole, helical and loop antennas. The single-ended monopole and helical would require a balun network between the differential output and the antenna.

Monopole antennas are resonant antennas with a length corresponding to one quarter of the electrical wavelength ($\lambda/4$). They are very easy to design and can be implemented simply as a “piece of wire” or even integrated into the PCB.

The length of the $\lambda/4$ -monopole antenna is given by:

$$L = 7125 / f$$

where f is in MHz, giving the length in cm. An antenna for 2450 MHz should be 2.9 cm.

Non-resonant monopole antennas shorter than $\lambda/4$ can also be used, but at the expense of range. In size and cost critical applications such an antenna may very well be integrated into the PCB.

Enclosing the antenna in high dielectric constant material reduces the overall size

of the antenna. Many vendors offer such antennas intended for PCB mounting.

Helical antennas can be thought of as a combination of a monopole and a loop antenna. They are a good compromise in size critical applications. Helical antennas tend to be more difficult to optimize than the simple monopole.

Loop antennas are easy to integrate into the PCB, but are less effective due to difficult impedance matching because of their very low radiation resistance.

For low power applications the differential antenna is recommended giving the best range and because of its simplicity.

The antenna should be connected as close as possible to the IC. If the antenna is located away from the RF pins the antenna should be matched to the feeding transmission line (50Ω).

Configuration Registers

The configuration of the **EM2420** is done by programming the 16-bit configuration registers. Complete descriptions of the registers are given in the following tables. After chip reset (from the `RESETn` pin or programmable through the `MAIN.RESETn` configuration bit), all the registers have default values as shown in the tables.

Note that the `MAIN` register is only reset by using the pin reset `RESETn`. When writing to this register, all bits will get the value written, not the default value. This also means that the `MAIN.RESETn` bit must be written both low and then high to perform a chip reset through the serial interface.

15 registers are Strobe Command Registers, listed first in Table 11 below. Accessing these registers will initiate the change of an internal state or mode. There are 33 normal 16-bits registers, also listed

in Table 11. Many of these registers are for test purposes only, and need not be accessed for normal operation of the **EM2420**.

The FIFOs are accessed through two 8-bit registers, `TXFIFO` and `RXFIFO`. The `TXFIFO` register is write only. Data may still be read out of the `TXFIFO` through regular RAM access (see section RAM access section on page 27), but data is then not removed from the FIFO. Note that the crystal oscillator must be active for all FIFO and RAM access.

During the address transfer and while writing to the `TXFIFO`, a status byte is returned on the serial data output pin `SO`. This status byte is described in Table 5 on page 27.

All configuration and status registers are described in the tables following Table 11.

Address	Register	Register type	Description
0x00	SNOP	S	No Operation (has no other effect than reading out status-bits)
0x01	SXOSCON	S	Turn on the crystal oscillator (set <code>XOSC16M_PD = 0</code> and <code>BIAS_PD = 0</code>)
0x02	STXCAL	S	Enable and calibrate frequency synthesizer for TX; go from RX / TX to a wait state where only the synthesizer is running.
0x03	SRXON	S	Enable RX
0x04	STXON	S	Enable TX after calibration (if not already performed) Start TX in-line encryption if <code>SPI_SEC_MODE ≠ 0</code>
0x05	STXONCCA	S	If CCA indicates a clear channel: Enable calibration, then TX. Start in-line encryption if <code>SPI_SEC_MODE ≠ 0</code> else do nothing
0x06	SRFOFF	S	Disable RX/TX and frequency synthesizer
0x07	SXOSCOFF	S	Turn off the crystal oscillator and RF
0x08	SFLUSHRX	S	Flush the RX FIFO buffer and reset the demodulator. Always read at least one byte from the <code>RXFIFO</code> before issuing the <code>SFLUSHRX</code> command strobe
0x09	SFLUSHTX	S	Flush the TX FIFO buffer
0x0A	SACK	S	Send acknowledge frame, with pending field cleared.
0x0B	SACKPEND	S	Send acknowledge frame, with pending field set.
0x0C	SRXDEC	S	Start <code>RXFIFO</code> in-line decryption / authentication (as set by <code>SPI_SEC_MODE</code>)
0x0D	STXENC	S	Start <code>TXFIFO</code> in-line encryption / authentication (as set by <code>SPI_SEC_MODE</code>), without starting TX.

Address	Register	Register type	Description
0x0E	SAES	S	AES Stand alone encryption strobe. SPI_SEC_MODE is not required to be 0, but the encryption module must be idle. If not, the strobe is ignored.
0x0F	-	-	Not used
0x10	MAIN	R/W	Main Control Register
0x11	MDMCTRL0	R/W	Modem Control Register 0
0x12	MDMCTRL1	R/W	Modem Control Register 1
0x13	RSSI	R/W	RSSI and CCA Status and Control register
0x14	SYNCWORD	R/W	Synchronisation word control register
0x15	TXCTRL	R/W	Transmit Control Register
0x16	RXCTRL0	R/W	Receive Control Register 0
0x17	RXCTRL1	R/W	Receive Control Register 1
0x18	FSCTRL	R/W	Frequency Synthesizer Control and Status Register
0x19	SECCTRL0	R/W	Security Control Register 0
0x1A	SECCTRL1	R/W	Security Control Register 1
0x1B	BATTMON	R/W	Battery Monitor Control and Status Register
0x1C	IOCFG0	R/W	Input / Output Control Register 0
0x1D	IOCFG1	R/W	Input / Output Control Register 1
0x1E	MANFIDL	R/W	Manufacturer ID, Low 16 bits
0x1F	MANFIDH	R/W	Manufacturer ID, High 16 bits
0x20	FSMTC	R/W	Finite State Machine Time Constants
0x21	MANAND	R/W	Manual signal AND override register
0x22	MANOR	R/W	Manual signal OR override register
0x23	AGCCTRL	R/W	AGC Control Register
0x24	AGCTST0	R/W	AGC Test Register 0
0x25	AGCTST1	R/W	AGC Test Register 1
0x26	AGCTST2	R/W	AGC Test Register 2
0x27	FSTST0	R/W	Frequency Synthesizer Test Register 0
0x28	FSTST1	R/W	Frequency Synthesizer Test Register 1
0x29	FSTST2	R/W	Frequency Synthesizer Test Register 2
0x2A	FSTST3	R/W	Frequency Synthesizer Test Register 3
0x2B	RXPFTST	R/W	Receiver Bandpass Filter Test Register
0x2C	FSMSTATE	R	Finite State Machine State Status Register
0x2D	ADCTST	R/W	ADC Test Register
0x2E	DACTST	R/W	DAC Test Register
0x2F	TOPTST	R/W	Top Level Test Register
0x30	RESERVED	R/W	Reserved for future use control / status register
0x31-0x3D	-	-	Not used
0x3E	TXFIFO	W	Transmit FIFO Byte Register
0x3F	RXFIFO	R/W	Receiver FIFO Byte Register

R/W - Read/write (control/status), R - Read only, W – Write only, S – Command Strobe (perform action upon access)

Table 11. Configuration registers overview

MAIN (0x10) - Main Control Register

Bit	Field Name	Reset	R/W	Description
15	RESETn	1	R/W	Active low reset of entire circuit, should be applied before doing anything else. Equivalent to using the RESETn reset pin.
14	ENC_RESETn	1	R/W	Active low reset of the encryption module. (Test purposes only)
13	DEMODO_RESETn	1	R/W	Active low reset of the demodulator module. (Test purposes only)
12	MOD_RESETn	1	R/W	Active low reset of the modulator module. (Test purposes only)
11	FS_RESETn	1	R/W	Active low reset of the frequency synthesizer module. (Test purposes only)
10:1	-	0	W0	Reserved, write as 0
0	XOSC16M_BYPASS	0	R/W	Bypasses the crystal oscillator and uses a buffered version of the signal on Q1 directly. This can be used to apply an external rail-rail clock signal to the Q1 pin.

MDMCTRL0 (0x11) - Modem Control Register 0

Bit	Field Name	Reset	R/W	Description
15:14	-	0	W0	Reserved, write as 0
13	RESERVED_FRAME_MODE	0	R/W	<p>Mode for accepting reserved IEEE 802.15.4 frame types when address recognition is enabled (MDMCTRL0.ADR_DECODE = 1).</p> <p>0 : Reserved frame types (100, 101, 110, 111) are rejected by address recognition.</p> <p>1 : Reserved frame types (100, 101, 110, 111) are always accepted by address recognition. No further address decoding is done.</p> <p>When address recognition is disabled (MDMCTRL0.ADR_DECODE = 0), all frames are received and RESERVED_FRAME_MODE is don't care.</p>
12	PAN_COORDINATOR	0	R/W	Should be set high when the device is a PAN Coordinator. Used for filtering packets with no destination address, as specified in section 7.5.6.2 in 802.15.4, D18
11	ADR_DECODE	1	R/W	<p>Hardware Address decode enable.</p> <p>0 : Address decoding is disabled</p> <p>1 : Address decoding is enabled</p>
10:8	CCA_HYST[2:0]	2	R/W	CCA Hysteresis in dB, values 0 through 7 dB
7:6	CCA_MODE[1:0]	3	R/W	<p>0 : Reserved</p> <p>1 : CCA=1 when $RSSI_VAL < CCA_THR - CCA_HYST$ CCA=0 when $RSSI_VAL \geq CCA_THR$</p> <p>2 : CCA=1 when not receiving valid IEEE 802.15.4 data, CCA=0 otherwise</p> <p>3 : CCA=1 when $RSSI_VAL < CCA_THR - CCA_HYST$ and not receiving valid IEEE 802.15.4 data. CCA=0 when $RSSI_VAL \geq CCA_THR$ or receiving a packet</p>
5	AUTOCRC	1	R/W	In packet mode a CRC-16 (ITU-T) is calculated and is transmitted after the last data byte in TX. In RX CRC is calculated and checked for validity.
4	AUTOACK	0	R/W	If AUTOACK is set, all packets accepted by address recognition with the acknowledge request flag set and a valid CRC are ack'ed 12 symbol periods after being received.
3:0	PREAMBLE_LENGTH [3:0]	2	R/W	<p>The number of preamble bytes (2 zero-symbols) to be sent in TX mode prior to the SYNCWORD, encoded in steps of 2. The reset value of 2 is compliant with IEEE 802.15.4, since the 4th zero byte is included in the SYNCWORD.</p> <p>0 : 1 leading zero bytes (not recommended)</p> <p>1 : 2 leading zero bytes (not recommended)</p> <p>2 : 3 leading zero bytes (IEEE 802.15.4 compliant)</p> <p>3 : 4 leading zero bytes</p> <p>...</p> <p>15 : 16 leading zero bytes</p>

MDMCTRL1 (0x12) – Modem Control Register 1

Bit	Field Name	Reset	R/W	Description
15:11	–	0	W0	Reserved, write as 0.
10:6	CORR_THR[4:0]	0	R/W	Demodulator correlator threshold value, required before SFD search. Should always be set to 20.
5	DEMOD_AVG_MODE	0	R/W	Frequency offset average filter behaviour. 0 : Lock frequency offset filter after preamble match 1 : Continuously update frequency offset filter.
4	MODULATION_MODE	0	R/W	Set one of two RF modulation modes for RX / TX 0 : IEEE 802.15.4 compliant mode 1 : Reversed phase, non-IEEE compliant (could be used to set up a system which will not receive 802.15.4 packets)
3:2	TX_MODE[1:0]	0	R/W	Set test modes for TX 0 : Buffered mode, use TXFIFO (normal operation) 1 : Serial mode, use transmit data on serial interface, infinite transmission. For lab testing only. 2 : TXFIFO looping ignore underflow in TXFIFO and read cyclic, infinite transmission. For lab testing only. 3 : Send random data from CRC, infinite transmission. For lab testing only.
1:0	RX_MODE[1:0]	0	R/W	Set test mode of RX 0 : Buffered mode, use RXFIFO (normal operation) 1 : Receive serial mode, output received data on pins. Infinite RX. For lab testing only. 2 : RXFIFO looping ignore overflow in RXFIFO and write cyclic, infinite reception. For lab testing only. 3 : Reserved

RSSI (0x13) - RSSI and CCA Status and Control Register

Bit	Field Name	Reset	R/W	Description
15:8	CCA_THR[7:0]	-32	R/W	Clear Channel Assessment threshold value, signed number on 2's complement for comparison with the RSSI. The unit is 1 dB; offset is the same as for <code>RSSI_VAL</code> . The CCA signal goes high when the received signal is below this value. The CCA signal is available on the <code>CCA</code> pin. The reset value is approximately -77 dBm.
7:0	RSSI_VAL[7:0]	-128	R	RSSI estimate on a logarithmic scale, signed number on 2's complement. Unit is 1 dB; offset is described in the RSSI / Energy Detection section on page 48. The <code>RSSI_VAL</code> value is averaged over 8 symbol periods. The <code>RSSI_VALID</code> status bit may be checked to verify that the receiver has been enabled for at least 8 symbol periods. The reset value of -128 also indicates that the <code>RSSI_VAL</code> value is invalid.

SYNCWORD (0x14) - Sync Word

Bit	Field Name	Reset	R/W	Description
15:0	SYNCWORD[15:0]	0xA70F	R/W	<p>Synchronisation word. The SYNCWORD is processed from the least significant nibble (F at reset) to the most significant nibble (A at reset).</p> <p>SYNCWORD is used both during modulation (where 0xF's are replaced with 0x0's) and during demodulation (where 0xF's are not required for frame synchronisation). In reception an implicit zero is required before the first symbol required by SYNCWORD.</p> <p>The reset value is compliant with IEEE 802.15.4.</p>

TXCTRL (0x15) - Transmit Control Register

Bit	Field Name	Reset	R/W	Description
15:14	TXMIXBUF_CUR[1:0]	1	R/W	<p>TX mixer buffer bias current.</p> <p>0: 690uA 1: 980uA (nominal) 2: 1.16mA 3: 1.44mA</p>
13	TX_TURNAROUND	1	R/W	<p>Sets the wait time after STXON before transmission is started.</p> <p>0: 8 symbol periods (128 us) 1: 12 symbol periods (192 us)</p>
12:11	TXMIX_CAP_ARRAY[1:0]	0	R/W	Selects varactor array settings in the transmit mixers.
10:9	TXMIX_CURRENT[1:0]	0	R/W	<p>Transmit mixers current:</p> <p>0: 1.72 mA 1: 1.88 mA 2: 2.05 mA 3: 2.21 mA</p>
8:6	PA_CURRENT[2:0]	3	R/W	<p>Current programming of the PA</p> <p>0: -3 current adjustment 1: -2 current adjustment 2: -1 current adjustment 3: Nominal setting 4: +1 current adjustment 5: +2 current adjustment 6: +3 current adjustment 7: +4 current adjustment</p>
5	PA_DIFF	1	R/W	Indicates whether PA output is differential (1) or single-ended (0).
4:0	PA_LEVEL[4:0]	31	R/W	Output PA level. (~0 dBm)

RXCTRL0 (0x16) – Receive control register 0

Bit	Field Name	Reset	R/W	Description
15:14	–	0	W0	Reserved, write as 0.
13:12	RXMIXBUF_CUR[1:0]	1	R/W	RX mixer buffer bias current. 0: 690uA 1: 980uA (nominal) 2: 1.16mA 3: 1.44mA
11:10	HIGH_LNA_GAIN[1:0]	0	R/W	Controls current in the LNA gain compensation branch in AGC High gain mode. 0: Compensation disabled 1: 100 µA compensation current 2: 300 µA compensation current (Nominal) 3: 1000 µA compensation current
9:8	MED_LNA_GAIN[1:0]	2	R/W	Controls current in the LNA gain compensation branch in AGC Med gain mode.
7:6	LOW_LNA_GAIN[1:0]	3	R/W	Controls current in the LNA gain compensation branch in AGC Low gain mode
5:4	HIGH_LNA_CURRENT[1:0]	2	R/W	Controls main current in the LNA in AGC High gain mode 0: 240 µA LNA current (x2) 1: 480 µA LNA current (x2) 2: 640 µA LNA current (x2) 3: 1280 µA LNA current (x2)
3:2	MED_LNA_CURRENT[1:0]	1	R/W	Controls main current in the LNA in AGC Med gain mode
1:0	LOW_LNA_CURRENT[1:0]	1	R/W	Controls main current in the LNA in AGC Low gain mode

RXCTRL1 (0x17) - Receive control register 1

Bit	Field Name	Reset	R/W	Description
15:14	-	0	W0	Reserved, write as 0.
13	RXBPF_LOCUR	0	R/W	Controls reference bias current to RX bandpass filters: 0: 4 μ A (Default) 1: 3 μ A
12	RXBPF_MIDCUR	0	R/W	Controls reference bias current to RX bandpass filters: 0: 4 μ A (Default) 1: 3.5 μ A
11	LOW_LOWGAIN	1	R/W	LNA low gain mode setting in AGC low gain mode.
10	MED_LOWGAIN	0	R/W	LNA low gain mode setting in AGC medium gain mode.
9	HIGH_HGM	1	R/W	RX Mixers high gain mode setting in AGC high gain mode.
8	MED_HGM	0	R/W	RX Mixers high gain mode setting in AGC medium gain mode.
7:6	LNA_CAP_ARRAY[1:0]	1	R/W	Selects varactor array setting in the LNA 0: OFF 1: 0.1pF (x2) (Nominal) 2: 0.2pF (x2) 3: 0.3pF (x2)
5:4	RXMIX_TAIL[1:0]	1	R/W	Control of the receiver mixers output current. 0: 12 μ A 1: 16 μ A (Nominal) 2: 20 μ A 3: 24 μ A
3:2	RXMIX_VCM[1:0]	1	R/W	Controls VCM level in the mixer feedback loop 0: 8 μ A mixer current 1: 12 μ A mixer current (Nominal) 2: 16 μ A mixer current 3: 20 μ A mixer current
1:0	RXMIX_CURRENT[1:0]	2	R/W	Controls current in the mixer 0: 360 μ A mixer current (x2) 1: 720 μ A mixer current (x2) 2: 900 μ A mixer current (x2) (Nominal) 3: 1260 μ A mixer current (x2)

FSCTRL (0x18) - Frequency Synthesizer Control and Status

Bit	Field Name	Reset	R/W	Description
15:14	LOCK_THR[1:0]	1	R/W	Number of consecutive reference clock periods with successful synchronisation windows required to indicate lock: 0: 64 1: 128 (recommended) 2: 256 3: 512
13	CAL_DONE	0	R	Calibration has been performed since the last time the frequency synthesizer was turned on.
12	CAL_RUNNING	0	R	Calibration status, '1' when calibration in progress and '0' otherwise.
11	LOCK_LENGTH	0	R/W	Synchronisation window pulse width: 0: 2 prescaler clock periods (recommended) 1: 4 prescaler clock periods
10	LOCK_STATUS	0	R	Frequency synthesizer lock status: 0 : Frequency synthesizer is out of lock 1 : Frequency synthesizer is in lock
9:0	FREQ[9:0]	357 (2405 MHz)	R/W	Frequency control word, controlling the RF operating frequency F_C . In transmit mode, the local oscillator (LO) frequency equals F_C . In receive mode, the LO frequency is 2 MHz below F_C . $F_C = 2048 + \text{FREQ}[9:0] \text{ MHz}$ See the Frequency and Channel Programming section on page 51 for further information.

SECCTRL0 (0x19) - Security Control Register

Bit	Field Name	Reset	R/W	Description
15:10	-	0	W0	Reserved, write as 0
9	RXFIFO_PROTECTION	1	R/W	Protection enable of the RXFIFO, see description in the RXFIFO overflow section on page 31. Should be cleared if MAC level security is not used or is implemented outside the EM2420 .
8	SEC_CBC_HEAD	1	R/W	Defines what to use for the first byte in CBC-MAC (does <i>not</i> apply to CBC-MAC part of CCM): 0 : Use the first data byte as the first byte into CBC-MAC 1 : Use the length of the data to be authenticated (calculated as (the packet length field – SEC_TXL – 2) for tx or using SEC_RXL for rx) as the first byte into CBC-MAC (before the first data byte). This bit should be set high for CBC-MAC 802.15.4 inline security.
7	SEC_SAKYSEL	1	R/W	Stand Alone Key select 0 : Key 0 is used 1 : Key 1 is used
6	SEC_TXKEYSEL	1	R/W	TX Key select 0 : Key 0 is used 1 : Key 1 is used
5	SEC_RXKEYSEL	0	R/W	RX Key select 0 : Key 0 is used 1 : Key 1 is used
4:2	SEC_M[2:0]	1	R/W	Number of bytes in authentication field for CBC-MAC, encoded as (M-2)/2 0 : Reserved 1 : 4 2 : 6 3 : 8 4 : 10 5 : 12 6 : 14 7 : 16
1:0	SEC_MODE[1:0]	0	R/W	Security mode 0 : In-line security is disabled 1 : CBC-MAC 2 : CTR 3 : CCM

SECCTRL1 (0x1A) - Security Control Register

Bit	Field Name	Reset	R/W	Description
15	-	0	W0	Reserved, write as 0
14:8	SEC_TXL	0	R/W	Multi-purpose length byte for TX in-line security operations: CTR : Number of cleartext bytes between length byte and the first byte to be encrypted CBC/MAC : Number of cleartext bytes between length byte and the first byte to be authenticated CCM : l(a), defining the number of bytes to be authenticated but not encrypted Stand-alone : SEC_TXL has no effect
7	-	0	W0	Reserved, write as 0
6:0	SEC_RXL	0	R/W	Multi-purpose length byte for RX in-line security operations: CTR : Number of cleartext bytes between length byte and the first byte to be decrypted CBC/MAC : Number of cleartext bytes between length byte and the first byte to be authenticated CCM : l(a), defining the number of bytes to be authenticated but not decrypted Stand-alone : SEC_RXL has no effect

BATTMON (0x1B) – Battery Monitor Control register

Bit	Field Name	Reset	R/W	Description
15:7	-	0	W0	Reserved, write as 0
6	BATT_OK	0	R	Battery monitor comparator output, read only. BATT_OK is valid 5 us after BATTMON_EN has been asserted and BATTMON_VOLTAGE has been programmed. 0 : Power supply < Toggle Voltage 1 : Power supply > Toggle Voltage
5	BATTMON_EN	0	R/W	Battery monitor enable 0 : Battery monitor is disabled 1 : Battery monitor is enabled
4:0	BATTMON_VOLTAGE [4:0]	0	R/W	Battery monitor toggle voltage. The toggle voltage is given by: $V_{toggle} = 1.25V \cdot \frac{72 - BATTMON_VOLTAGE}{27}$

IOCFG0 (0x1C) – I/O Configuration Register 0

Bit	Field Name	Reset	R/W	Description
15:12	–	0	W0	Reserved, write as 0
11	–	0	R/W	Reserved, write as 0
10	FIFOP_POLARITY	0	R/W	Polarity of the output signal FIFO. 0 : Polarity is as described in the specification 1 : Polarity is inverted as compared to the specification
9	FIFOP_POLARITY	0	R/W	Polarity of the output signal FIFOP. 0 : Polarity is as described in the specification 1 : Polarity is inverted as compared to the specification
8	SFD_POLARITY	0	R/W	Polarity of the SFD pin. 0 : Polarity is as described in the specification 1 : Polarity is inverted as compared to the specification
7	CCA_POLARITY	0	R/W	Polarity of the CCA pin.
6:0	FIFOP_THR[6:0]	64	R/W	FIFOP_THR sets the threshold in number of bytes in the RXFIFO for FIFOP to go high.

IOCFG1 (0x1D) – I/O Configuration Register 1

Bit	Field Name	Reset	R/W	Description
15:13	–	0	W0	Reserved, write as 0
12:10	HSSD_SRC[2:0]	0	R/W	The HSSD module is used as follows: 0: Off. 1: Output AGC status (gain setting / peak detector status / accumulator value) 2: Output ADC I and Q values. 3: Output I/Q after digital downmix and channel filtering. 4: Reserved 5: Reserved 6: Input ADC I and Q values 7: Input DAC I and Q values. The HSSD module requires that the FS is up and running as it uses CLK_PRE (~150 MHz) to produce its ~37.5 MHz data clock and serialize its output words.
9:5	SFDMUX[4:0]	0	R/W	Multiplexer setting for the SFD pin.
4:0	CCAMUX[4:0]	0	R/W	Multiplexer setting for the CCA pin.

MANFIDL (0x1E) - Manufacturer ID, Lower 16 Bi

Bit	Field Name	Reset	R/W	Description
15:12	PARTNUM[3:0]	2	R	The device part number. The EM2420 has part number 0x002.
11:0	MANFID[11:0]	0x33D	R	Gives the JEDEC manufacturer ID. The actual manufacturer ID can be found in MANFID[7:1], the number of continuation bytes in MANFID[11:8] and MANFID[0]=1. The JEDEC manufacturer ID is 0x7F 0x7F 0x7F 0x9E (0x1E preceded by three continuation bytes.)

MANFIDH (0x1F) - Manufacturer ID, Upper 16 Bit

Bit	Field Name	Reset	R/W	Description
15:12	VERSION[3:0]	0	R	Version number. Current number is 0.
11:0	PARTNUM[15:4]	0	R	The device part number. EM2420 has part number 0x002.

FSMTC (0x20) - Finite state machine time constants

Bit	Field Name	Reset	R/W	Description
15:13	TC_RXCHAIN2RX[2:0]	3	R/W	The time in 5 us steps between the time the RX chain is enabled and the demodulator and AGC is enabled. The RX chain is started when the bandpass filter has been calibrated (after 6.5 symbol periods).
12:10	TC_SWITCH2TX[2:0]	6	R/W	The time in advance the PA is powered up before enabling TX. In μ s.
9:6	TC_PAON2TX[3:0]	10	R/W	The time in advance the RXTX switch is set high, before enabling TX. In μ s.
5:3	TC_TXEND2SWITCH[2:0]	2	R/W	The time after the last chip in the packet is sent, and the rxtx switch is disabled. in μ s.
2:0	TC_TXEND2PAOFF[2:0]	4	R/W	The time after the last chip in the packet is sent, and the PA is set in power-down. Also the time at which the modulator is disabled. In μ s.

MANAND (0x21) - Manual signal AND override register¹

Bit	Field Name	Reset	R/W	Description
15	VGA_RESET_N	1	R/W	The VGA_RESET_N signal is used to reset the peak detectors in the VGA in the RX chain.
14	BIAS_PD	1	R/W	Reserved, write as 0
13	BALUN_CTRL	1	R/W	The BALUN_CTRL signal controls whether the PA should receive its required external biasing (1) or not (0) by controlling the RX/TX output switch.
12	RXTX	1	R/W	RXTX signal: controls whether the LO buffers (0) or PA buffers (1) should be used.
11	PRE_PD	1	R/W	Powerdown of prescaler.
10	PA_N_PD	1	R/W	Powerdown of PA (negative path).
9	PA_P_PD	1	R/W	Powerdown of PA (positive path). When PA_N_PD=1 and PA_P_PD=1 the up-conversion mixers are in powerdown.
8	DAC_LPF_PD	1	R/W	Powerdown of TX DACs.
7	XOSC16M_PD	1	R/W	
6	RXBPF_CAL_PD	1	R/W	Powerdown control of complex bandpass receive filter calibration oscillator.
5	CHP_PD	1	R/W	Powerdown control of charge pump.
4	FS_PD	1	R/W	Powerdown control of VCO, I/Q generator, LO buffers.
3	ADC_PD	1	R/W	Powerdown control of the ADCs.
2	VGA_PD	1	R/W	Powerdown control of the VGA.
1	RXBPF_PD	1	R/W	Powerdown control of complex bandpass receive filter.
0	LNAMIX_PD	1	R/W	Powerdown control of LNA, down-conversion mixers and front-end bias.

¹ For some important signals the value used by analog and digital modules can be overridden manually. This is done as follows for the hypothetical important signal *IS*:

$$IS_USED = (IS * IS_AND_MASK) + IS_OR_MASK,$$

using Boolean notation.

The AND-mask and OR-mask for the important signals listed resides in the MANAND and MANOR registers, respectively.

Examples:

- Writing 0xFFFFE to MANAND and 0x0000 to MANOR will force LNAMIX_PD=0 whereas all other signals will be unaffected.
- Writing 0xFFFF to MANAND and 0x0001 to MANOR will force LNAMIX_PD=1 whereas all other signals will be unaffected.

MANOR (0x22) - Manual signal OR override register

Bit	Field Name	Reset	R/W	Description
15	VGA_RESET_N	0	R/W	The VGA_RESET_N signal is used to reset the peak detectors in the VGA in the RX chain.
14	BIAS_PD	0	R/W	Global Bias power down (1)
13	BALUN_CTRL	0	R/W	The BALUN_CTRL signal controls whether the PA should receive its required external biasing (1) or not (0) by controlling the RX/TX output switch.
12	RXTX	0	R/W	RXTX signal: controls whether the LO buffers (0) or PA buffers (1) should be used.
11	PRE_PD	0	R/W	Powerdown of prescaler.
10	PA_N_PD	0	R/W	Powerdown of PA (negative path).
9	PA_P_PD	0	R/W	Powerdown of PA (positive path). When PA_N_PD=1 and PA_P_PD=1 the up-conversion mixers are in powerdown.
8	DAC_LPF_PD	0	R/W	Powerdown of TX DACs.
7	XOSC16M_PD	0		
6	RXBPF_CAL_PD	0	R/W	Powerdown control of complex bandpass receive filter calibration oscillator.
5	CHP_PD	0	R/W	Powerdown control of charge pump.
4	FS_PD	0	R/W	Powerdown control of VCO, I/Q generator, LO buffers.
3	ADC_PD	0	R/W	Powerdown control of the ADCs.
2	VGA_PD	0	R/W	Powerdown control of the VGA.
1	RXBPF_PD	0	R/W	Powerdown control of complex bandpass receive filter.
0	LNAMIX_PD	0	R/W	Powerdown control of LNA, down-conversion mixers and front-end bias.

AGCCTRL (0x23) - AGC Control

Bit	Field Name	Reset	R/W	Description
15:12	-	0	W0	Reserved, write as 0
11	VGA_GAIN_OE	0	R/W	Use the VGA_GAIN value during RX instead of the AGC value.
10:4	VGA_GAIN [6:0]	0x7F	R/W	When written, VGA manual gain override value; when read, the currently used VGA gain setting.
3:2	LNAMIX_GAINMODE_O [1:0]	0	R/W	LNA / Mixer Gain mode override setting 0 : Gain mode is set by AGC algorithm 1 : Gain mode is always low-gain 2 : Gain mode is always med-gain 3 : Gain mode is always high-gain
1:0	LNAMIX_GAINMODE [1:0]	0	R	Status bit, defining the currently selected gainmode selected by the AGC or overridden by the LNAMIX_GAINMODE_O setting.

AGCTST0 (0x24) - AGC Test Register 0

Bit	Field Name	Reset	R/W	Description
15:12	LNAMIX_HYST[3:0]	3	R/W	Hysteresis on the switching between different RF front-end gain modes, defined in 2 dB steps
11:6	LNAMIX_THR_H[5:0]	25	R/W	Threshold for switching between medium and high RF front-end gain mode, defined in 2 dB steps
5:0	LNAMIX_THR_L[5:0]	9	R/W	Threshold for switching between low and medium RF front-end

Bit	Field Name	Reset	R/W	Description
				gain mode, defined in 2 dB steps

AGCTST1 (0x25) - AGC Test Register 1

Bit	Field Name	Reset	R/W	Description
15	-	0	W0	Reserved, write as 0
14	AGC_BLANK_MODE	0	R/W	Set the VGA blanking mode when switching out a gainstage When VGA_GAIN_OE = 0: 0 : Blanking is performed when the AGC algorithm switches out one or more 14dB gain stages. 1 : Blanking is never performed. When VGA_GAIN_OE = 1: Blanking is performed when AGC_BLANK_MODE=1
13	PEAKDET_CUR_BOOST	0	R/W	Doubles the bias current in the peak detectors in between the VGA stages when set.
12:11	AGC_SETTLE_WAIT[1:0]	1	R/W	Timing for AGC to wait for analog gain to settle.
10:8	AGC_PEAK_DET_MODE [2:0]	0	R/W	Sets the AGC mode for use of the VGA peak detectors: Bit 2 : Digital ADC peak detector enable / disable Bit 1 : Analog fixed stages peak detector enable / disable Bit 0 : Analog variable gain stage peak detector enable / disable
7:6	AGC_WIN_SIZE[1:0]	1	R/W	Window size for the accumulate and dump function in the AGC. 0 : 8 samples 1 : 16 samples 2 : 32 samples 3 : 64 samples
5:0	AGC_REF[5:0]	20	R/W	Target value for the AGC control loop, given in 2 dB steps. Reset value corresponds to approximately 25% of the ADC dynamic range in reception.

AGCTST2 (0x26) - AGC Test Register 2

Bit	Field Name	Reset	R/W	Description
15:10	-	0	W0	Reserved, write as 0
9:5	MED2HIGHGAIN[4:0]	9	R/W	MED2HIGHGAIN sets the difference in the receiver LNA/MIXER gain from medium gain mode to high gain mode, used by the AGC for setting the correct front-end gain mode.
4:0	LOW2MEDGAIN[4:0]	10	R/W	LOW2MEDGAIN sets the difference in the receiver LNA/MIXER gain from low gain mode to medium gain mode, used by the AGC for setting the correct front-end gain mode.

FSTST0 (0x27) - Frequency Synthesizer Test Register 0

Bit	Field Name	Reset	R/W	Description
15:12	-	0	W0	Reserved, write as 0
11	VCO_ARRAY_SETTLE_LONG	0	R/W	When '1' this control bit doubles the time allowed for VCO settling during VCO calibration.
10	VCO_ARRAY_OE	0	R/W	VCO array manual override enable.
9:5	VCO_ARRAY_O[4:0]	16	R/W	VCO array override value.
4:0	VCO_ARRAY_RES[4:0]	-	R	The resulting VCO array setting from the last calibration.

FSTST1 (0x28) - Frequency Synthesizer Test Register 1

Bit	Field Name	Reset	R/W	Description
15	VCO_TX_NOCAL	0	R/W	0 : VCO calibration is always performed when going to RX or when going to TX. 1 : VCO calibration is only performed when going to RX or when using the STXCAL command strobe
14	VCO_ARRAY_CAL_LONG	1	R/W	When '1' this control bit doubles the time allowed for VCO frequency measurements during VCO calibration. 0 : PLL Calibration time is 37 us 1 : PLL Calibration time is 57 us
13:10	VCO_CURRENT_REF[3:0]	4	R/W	The value of the reference current calibrated against during VCO calibration.
9:4	VCO_CURRENT_K[5:0]	0	R/W	VCO current calibration constant. (current B override value when FSTST2.VCO_CURRENT_OE=1.)
3	VC_DAC_EN	0	R/W	Controls the source of the VCO VC node in normal operation (PAMTST.VC_IN_TEST_EN=0): 0: Loop filter (closed loop PLL) 1: VC DAC (open loop PLL)
2:0	VC_DAC_VAL[2:0]	2	R/W	VC DAC output value

FSTST2 (0x29) - Frequency Synthesizer Test Register 2

Bit	Field Name	Reset	R/W	Description
15	-	0	W0	Reserved, write as 0.
14:13	VCO_CURCAL_SPEED[1:0]	0	R/W	VCO current calibration speed: 0: Normal 1: Double speed 2: Half speed 3: Undefined.
12	VCO_CURRENT_OE	0	R/W	VCO current manual override enable.
11:6	VCO_CURRENT_O[5:0]	24	R/W	VCO current override value (current A).
5:0	VCO_CURRENT_RES[5:0]	-	R	The resulting VCO current setting from last calibration.

FSTST3 (0x2A) - Frequency Synthesizer Test Register 3

Bit	Field Name	Reset	R/W	Description
15	CHP_CAL_DISABLE	1	R/W	Disable charge pump during VCO calibration when set.
14	CHP_CURRENT_OE	0	R/W	Charge pump current override enable 0 : Charge pump current set by calibration 1 : Charge pump current set by START_CHP_CURRENT
13	CHP_TEST_UP	0	R/W	Forces the CHP to output "up" current when set
12	CHP_TEST_DN	0	R/W	Forces the CHP to output "down" current when set
11	CHP_DISABLE	0	R/W	Set to manually disable charge pump by masking the up and down pulses from the phase-detector.
10	PD_DELAY	0	R/W	Selects short or long reset delay in phase detector: 0: Short reset delay 1: Long reset delay
9:8	CHP_STEP_PERIOD[1:0]	2	R/W	The charge pump current value step period: 0: 0.25 us 1: 0.5 us 2: 1 us 3: 4 us
7:4	STOP_CHP_CURRENT[3:0]	13	R/W	The charge pump current to stop at after the current is stepped down from START_CHP_CURRENT after VCO calibration is complete. The current is stepped down periodically with intervals as defined in CHP_STEP_PERIOD.
3:0	START_CHP_CURRENT[3:0]	13	R/W	The charge pump current to start with after VCO calibration is complete. The current is then stepped down periodically to the value STOP_CHP_CURRENT with intervals as defined in CHP_STEP_PERIOD. Also used for overriding the charge pump current when CHP_CURRENT_OE='1'

RXBPFST (0x2B) - Receiver Bandpass Filters Test Register

Bit	Field Name	Reset	R/W	Description
15	-	0	W0	Reserved, write as 0.
14	RXBPF_CAP_OE	0	R/W	RX bandpass filter capacitance calibration override enable.
13:7	RXBPF_CAP_O[6:0]	0	R/W	RX bandpass filter capacitance calibration override value.
6:0	RXBPF_CAP_RES[6:0]	-	R	RX bandpass filter capacitance calibration result. 0 Minimum capacitance in the feedback. 1: Second smallest capacitance setting. ... 127: Maximum capacitance in the feedback.

FSMSTATE (0x2C) - Finite state machine information

Bit	Field Name	Reset	R/W	Description
15:6	-	0	W0	Reserved, write as 0.
5:0	FSM_CUR_STATE[5:0]	-	R	Gives the current state of the FIFO and Frame Control (FFCTRL) finite state machine. See the Radio control state machine section on page 42 for details.

ADCTST (0x2D) - ADC Test Register

Bit	Field Name	Reset	R/W	Description
15	ADC_CLOCK_DISABLE	0	R/W	ADC Clock Disable 0 : Clock enabled when ADC enabled 1 : Clock disabled, even if ADC is enabled
14:8	ADC_I[6:0]	-	R	Read the current ADC I-branch value.
7	-	0	W0	Reserved, write as 0.
6:0	ADC_Q[6:0]	-	R	Read the current ADC Q-branch value.

DACTST (0x2E) - DAC Test Register

Bit	Field Name	Reset	R/W	Description
15	-	0	W0	Reserved, write as 0.
14:12	DAC_SRC[2:0]	0	R/W	The TX DACs data source is selected by DAC_SRC according to: 0: Normal operation (from modulator). 1: The DAC_I_O and DAC_Q_O override values below.- 2: From ADC, most significant bits 3: I/Q after digital downmixing and channel filtering. 4: Full-spectrum White Noise (from CRC) 5: From ADC, least significant bits 6: RSSI / Cordic Magnitude Output 7: HSSD module. This feature will often require the DACs to be manually turned on in MANOVR and PAMTST.ATESTMOD_MODE=4.
11:6	DAC_I_O[5:0]	0	R/W	I-branch DAC override value.
5:0	DAC_Q_O[5:0]	0	R/W	Q-branch DAC override value.

Bit	Field Name	Reset	R/W	Description
TOPTS T (0x2F) - Top Level Test Register Bit	Field Name	Reset	R/W	Description
15:8	-	0	W0	Reserved, write as 0.
7	RAM_BIST_RUN	0	R/W	Enable BIST of the RAM 0 : RAM BIST disabled, normal operation 1 : RAM BIST Enabled. Result output to pin, as set in IOCFG1.
6	TEST_BATTMON_EN	0	R/W	Enable test output of the battery monitor.
5	VC_IN_TEST_EN	0	R/W	When ATESTMOD_MODE=7 this controls whether the ATEST2 in is used to output the VC node voltage (0) or to control the VC node voltage (1).
4	ATESTIMOD_PD	1	R/W	Powerdown of analog test module. 0 : Power up 1 : Power down
3:0	ATESTIMOD_MODE[3:0]			When ATESTMOD_PD=0, the function of the analog test module is as follows: 0: Outputs "I" (ATEST1) and "Q" (ATEST2) from RxMIX. 1: Inputs "I" (ATEST2) and "Q" (ATEST1) to BPF. 2: Outputs "I" (ATEST1) and "Q" (ATEST2) from VGA. 3: Inputs "I" (ATEST2) and "Q" (ATEST1) to ADC. 4: Outputs "I" (ATEST1) and "Q" (ATEST2) from LPF. 5: Inputs "I" (ATEST2) and "Q" (ATEST1) to TxMIX. 6: Outputs "P" (ATEST1) and "N" (ATEST2) from Prescaler. Must be terminated externally. 7: Connects TX IF to RX IF and simultaneously the ATEST1 pin to the internal VC node (see VC_IN_TEST_EN). 8. Connect ATEST1 (input) to ATEST2 (output) through single2diff and diff2single buffers, used for measurements on the test-interface

RESERVED (0x30) - Reserved register containing spare control and status bits

Bit	Field Name	Reset	R/W	Description
15:0	RES[15:0]	0	R/W	Reserved for future use

TXFIFO (0x3E) – Transmit FIFO Byte register

Bit	Field Name	Reset	R/W	Description
7:0	TXFIFO[7:0]	-	W	Transmit FIFO byte register, write only. Reading the TXFIFO is only possible using RAM read. Note that the crystal oscillator must be running for writing to the TXFIFO.

RXFIFO (0x3F) – Receive FIFO Byte register

Bit	Field Name	Reset	R/W	Description
7:0	RXFIFO[7:0]	-	R/W	Receive FIFO byte register, read / write. Note that the crystal

Bit	Field Name	Reset	R/W	Description
				oscillator must be running for accessing the RXFIFO.

Test Output Signals

The two digital output pins SFD and CCA, can be set up to output test signals defined by `IOCFG1.SFDMUX` and

`IOCFG1.CCAMUX`. This is summarized in Table 12 and Table 13 below.

SFDMUX	Signal output on SFD pin	Description
0	SFD	Normal operation
1	ADC_Q[0]	ADC, Q-branch, LSB used for random number generation
2	DEMOD_RESYNC_LATE	High one 16 MHz clock cycle each time the demodulator resynchronises late
3	LOCK_STATUS	Lock status, same as <code>FSCTRL.LOCK_STATUS</code>
4	MOD_CHIPCLK	Chip rate clock signal during transmission
5	MOD_SERIAL_CLK	Bit rate clock signal during transmission
6	FFCTRL_FS_PD	Frequency synthesizer power down, active high
7	FFCTRL_ADC_PD	ADC power down, active high
8	FFCTRL_VGA_PD	VGA power down, active high
9	FFCTRL_RXBPF_PD	Receiver bandpass filter power down, active high
10	FFCTRL_LNAMIX_PD	Receiver LNA / Mixer power down, active high
11	FFCTRL_PA_P_PD	Power amplifier power down, active high
12	AGC_UPDATE	High one 16 MHz clock cycle each time the AGC updates its gain setting
13	VGA_PEAK_DET[1]	VGA Peak detector, gain stage 1
14	VGA_PEAK_DET[3]	VGA Peak detector, gain stage 3
15	AGC_LNAMIX_GAINMODE[1]	RF receiver front-end gain mode, bit 1
16	AGC_VGA_GAIN[1]	VGA gain setting, bit 1
17	VGA_RESET_N	VGA peak detector reset signa, active low.
18	-	Reserved
19	-	Reserved
20	-	Reserved
21	-	Reserved
22	-	Reserved
23	CLK_8M	8 MHz clock signal output
24	XOSC16M_STABLE	16 MHz crystal oscillator stabilised, same as the status bit in Table 5
25	FSDIG_FREF	Frequency synthesizer, 4 MHz reference signal
26	FSDIG_FPLL	Frequency synthesizer, 4 MHz divided signal
27	FSDIG_LOCK_WINDOW	Frequency synthesizer, lock window
28	WINDOW_SYNC	Frequency synthesizer, synchronized lock window
29	CLK_ADC	ADC clock signal 1
30	ZERO	Low
31	ONE	High

Table 12. SFD test signal select table

CCAMUX	Signal output on CCA pin	Description
0	CCA	Normal operation
1	ADC_I[0]	ADC, I-branch, LSB used for random number generation
2	DEMOD_RESYNCH_EARLY	High one 16 MHz clock cycle each time the demodulator resynchronises early
3	LOCK_STATUS	Lock status, same as <code>FSCTRL.LOCK_STATUS</code>
4	MOD_CHIP	Chip rate data signal during transmission
5	MOD_SERIAL_DATA_OUT	Bit rate data signal during transmission
6	FFCTRL_FS_PD	Frequency synthesizer power down, active high
7	FFCTRL_ADC_PD	ADC power down, active high
8	FFCTRL_VGA_PD	VGA power down, active high
9	FFCTRL_RXBPF_PD	Receiver bandpass filter power down, active high
10	FFCTRL_LNAMIX_PD	Receiver LNA / Mixer power down, active high
11	FFCTRL_PA_P_PD	Power amplifier power down, active high
12	VGA_PEAK_DET[0]	VGA Peak detector, gain stage 0
13	VGA_PEAK_DET[2]	VGA Peak detector, gain stage 2
14	VGA_PEAK_DET[4]	VGA Peak detector, gain stage 4
15	AGC_LNAMIX_GAINMODE[0]	RF receiver front-end gain mode, bit 0
16	AGC_VGA_GAIN[0]	VGA gain setting, bit 0
17	RXBPF_CAL_CLK	Receiver bandpass filter calibration clock
18	-	Reserved
19	-	Reserved
20	-	Reserved
21	-	Reserved
22	-	Reserved
23	-	Reserved
24	PD_F_COMP	Frequency synthesizer frequency comparator value
25	FSDIG_FREF	Frequency synthesizer, 4 MHz reference signal
26	FSDIG_FPLL	Frequency synthesizer, 4 MHz divided signal
27	FSDIG_LOCK_WINDOW	Frequency synthesizer, lock window
28	WINDOW_SYNC	Frequency synthesizer, synchronized lock window
29	CLK_ADC_DIG	ADC clock signal 2
30	ZERO	Low
31	ONE	High

Table 13. CCA test signal select table

Package Description (QLP 48)

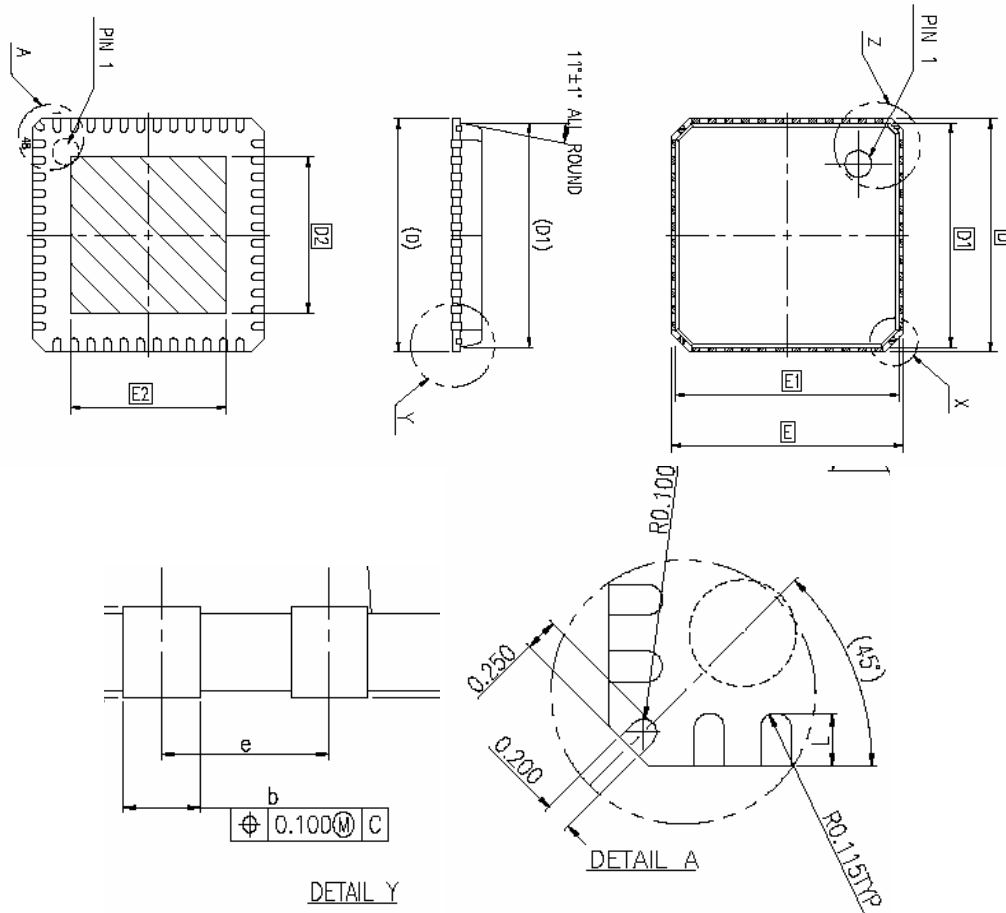

Note: The figure is an illustration only and not to scale.

Quad Leadless Package (QLP)										
		D	D1	E	E1	e	b	L	D2	E2
QLP 48	Min	6.9	6.65	6.9	6.65		0.18	0.3	5.05	5.05
		7.0	6.75	7.0	6.75	0.5		0.4	5.10	5.10
	Max	7.1	6.85	7.1	6.85		0.30	0.5	5.15	5.15
All dimensions in mm										

The package is compliant to JEDEC standard MO-220.

Package thermal properties

Thermal resistance	
Air velocity [m/s]	0
Rth,j-a [K/W]	25.6

Soldering information

Recommended soldering profile is according to IPC/JEDEC J-STD-020B, July 2002.

Plastic tube specification

QLP 7x 7 mm antistatic tube.

Tube Specification				
Package	Tube Width	Tube Height	Tube Length	Units per Tube
QLP 48	8.5 ± 0.2 mm	2.2 +0.2/-0.1 mm	315 ± 1.25 mm	43

Carrier tape and reel specification

Carrier tape and reel is in accordance with EIA Specification 481.

Tape and Reel Specification					
Package	Tape Width	Component Pitch	Hole Pitch	Reel Diameter	Units per Reel
QLP 48	16 mm	12 mm	4 mm	13 inch	4000

Ordering Information

Ordering part number	Description	MOQ
EM2420	Single Chip RF Transceiver and EmberNet Networking Stack	43
EM2420TR	Single Chip RF Transceiver and EmberNet Networking Stack	4000
EM2420EK	EM2420 Ember Evaluation Kit	1
EM2420DK	EM2420 Ember Developer Kit	1

MOQ = Minimum Order Quantity

General Information

Product Status Definitions

Data Sheet Identification	Product Status	Definition
Advance Information	Planned or Under Development	This data sheet contains the design specifications for product development. Specifications may change in any manner without notice.
Preliminary	Engineering Samples and First Production	This data sheet contains preliminary data, and supplementary data will be published at a later date. Ember reserves the right to make changes at any time without notice in order to improve design and supply the best possible product.
No Identification Noted	Full Production	This data sheet contains the final specifications. Ember reserves the right to make changes at any time without notice in order to improve design and supply the best possible product.
Obsolete	Not In Production	This data sheet contains specifications on a product that has been discontinued by Ember. The data sheet is printed for reference information only.

Copyright © 2003, 2004 by Ember Corporation

All rights reserved.

The information in this document is subject to change without notice. The statements, configurations, technical data, and recommendations in this document are believed to be accurate and reliable but are presented without express or implied warranty. Users must take full responsibility for their applications of any products specified in this document. The information in this document is the property of Ember Corporation.

Title, ownership, and all rights in copyrights, patents, trademarks, trade secrets and other intellectual property rights in the Ember Proprietary Products and any copy, portion, or modification thereof, shall not transfer to Purchaser or its customers and shall remain in Ember and its licensors.

No source code rights are granted to Purchaser or its customers with respect to all Ember Application Software. Purchaser agrees not to copy, modify, alter, translate, decompile, disassemble, or reverse engineer the Ember Hardware (including without limitation any embedded software) or attempt to disable any security devices or codes incorporated in the Ember Hardware. Purchaser shall not alter, remove, or obscure any printed or displayed legal notices contained on or in the Ember Hardware.

EmberNet, Ember Enabled, Ember, and the Ember logo are trademarks of Ember Corporation.

All other trademarks are the property of their respective holders.