

## Features

- Serial Peripheral Interface (SPI) Compatible
- Supports SPI Modes 0 (0,0) and 3 (1,1)
  - Datasheet describes Mode 0 Operation
- 20 MHz Clock Rate
- Byte Mode and 256-byte Page Mode for Program Operations
- Sector Architecture:
  - Eight Sectors with 64K Bytes Each (4M)
  - 256 Pages per Sector
- Product Identification Mode
- Low-voltage Operation
  - 2.7 ( $V_{CC} = 2.7V$  to 3.6V)
- Sector Write Protection
  - Protect 1/8, 1/4, 1/2 or Entire Array
- Write Protect ( $\overline{WP}$ ) Pin and Write Disable Instructions for both Hardware and Software Data Protection
- Self-timed Program Cycle (30  $\mu s$ /Byte Typical)
- Self-timed Sector Erase Cycle (1 second/Sector Typical)
- Single Cycle Reprogramming (Erase and Program) for Status Register
- High Reliability
  - Endurance: 10,000 Write Cycles Typical
- 8-lead EIAJ SOIC

## Description

The AT25F4096 provides 4,194,304 bits of serial reprogrammable Flash memory organized as 524,288 words of 8 bits each. The device is optimized for use in many industrial and commercial applications where low-power and low-voltage operation are essential. The AT25F4096 is available in a space-saving 8-lead EIAJ SOIC package.

## Pin Configurations

Pin Name	Function
$\overline{CS}$	Chip Select
SCK	Serial Data Clock
SI	Serial Data Input
SO	Serial Data Output
GND	Ground
VCC	Power Supply
$\overline{WP}$	Write Protect
$\overline{HOLD}$	Suspends Serial Input

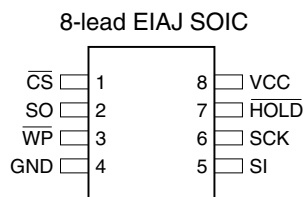

## SPI Serial Memory

4M (524,288 x 8)

## AT25F4096

## Advance Information



The AT25F4096 is enabled through the Chip Select pin ( $\overline{CS}$ ) and accessed via a 3-wire interface consisting of Serial Data Input (SI), Serial Data Output (SO), and Serial Clock (SCK). All write cycles are completely self-timed.

BLOCK WRITE protection for top 1/8, top 1/4, top 1/2 or the entire memory array is enabled by programming the status register. Separate write enable and write disable instructions are provided for additional data protection. Hardware data protection is provided via the  $\overline{WP}$  pin to protect against inadvertent write attempts to the status register. The  $\overline{HOLD}$  pin may be used to suspend any serial communication without resetting the serial sequence.

### Absolute Maximum Ratings\*

Operating Temperature.....	-40°C to +85°C
Storage Temperature.....	-65°C to +150°C
Voltage on Any Pin with Respect to Ground.....	-1.0V to +3.6V
Maximum Operating Voltage.....	3.6V
DC Output Current.....	5.0 mA

\*NOTICE: Stresses beyond those listed under “Absolute Maximum Ratings” may cause permanent damage to the device. This is a stress rating only and functional operation of the device at these or any other conditions beyond those indicated in the operational sections of this specification is not implied. Exposure to absolute maximum rating conditions for extended periods may affect device reliability.

### Block Diagram

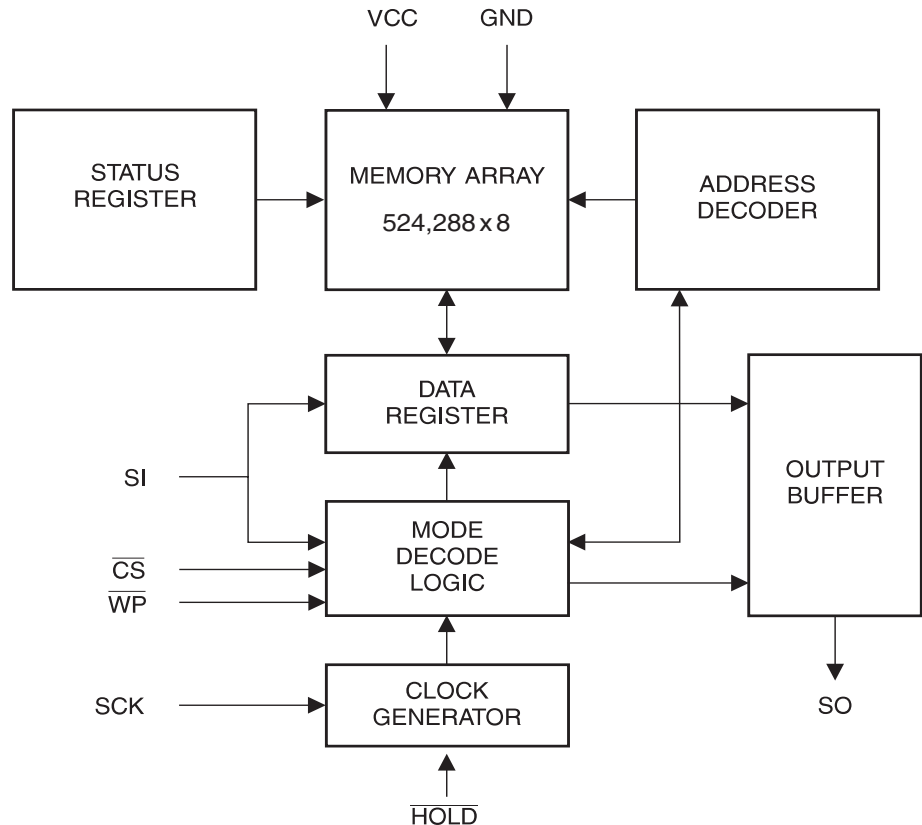

## Pin Capacitance<sup>(1)</sup>

Applicable over recommended operating range from  $T_A = 25^\circ\text{C}$ ,  $f = 1.0\text{ MHz}$ ,  $V_{CC} = +3.6\text{V}$  (unless otherwise noted).

Symbol	Test Conditions	Max	Units	Conditions
$C_{OUT}$	Output Capacitance (SO)	8	pF	$V_{OUT} = 0\text{V}$
$C_{IN}$	Input Capacitance ( $\overline{CS}$ , SCK, SI, $\overline{WP}$ , $\overline{HOLD}$ )	6	pF	$V_{IN} = 0\text{V}$

Note: 1. This parameter is characterized and is not 100% tested.

## DC Characteristics (Preliminary – Subject to Change)

Applicable over recommended operating range from:  $T_{AI} = -40^\circ\text{C}$  to  $+85^\circ\text{C}$ ,  $V_{CC} = +2.7\text{V}$  to  $+3.6\text{V}$ ,  $T_{AC} = 0^\circ\text{C}$  to  $+70^\circ\text{C}$ ,  $V_{CC} = +2.7\text{V}$  to  $+3.6\text{V}$  (unless otherwise noted).

Symbol	Parameter	Test Condition	Min	Typ	Max	Units
$V_{CC}$	Supply Voltage		2.7		3.6	V
$I_{CC1}$	Supply Current	$V_{CC} = 3.6\text{V}$ at 20 MHz, SO = Open Read		10.0	15.0	mA
$I_{CC2}$	Supply Current	$V_{CC} = 3.6\text{V}$ at 20 MHz, SO = Open Write		15.0	30.0	mA
$I_{SB}$	Standby Current	$V_{CC} = 2.7\text{V}$ , $\overline{CS} = V_{CC}$		2.0	10.0	$\mu\text{A}$
$I_{IL}$	Input Leakage	$V_{IN} = 0\text{V}$ to $V_{CC}$	-3.0		3.0	$\mu\text{A}$
$I_{OL}$	Output Leakage	$V_{IN} = 0\text{V}$ to $V_{CC}$ , $T_{AC} = 0^\circ\text{C}$ to $70^\circ\text{C}$	-3.0		3.0	$\mu\text{A}$
$V_{IL}^{(1)}$	Input Low Voltage		-0.6		$V_{CC} \times 0.3$	V
$V_{IH}^{(1)}$	Input High Voltage		$V_{CC} \times 0.7$		$V_{CC} + 0.5$	V
$V_{OL}$	Output Low Voltage	$2.7\text{V} \leq V_{CC} \leq 3.6\text{V}$			0.2	V
$V_{OH}$	Output High Voltage		$I_{OL} = 0.15\text{ mA}$			V
						V
			$V_{CC} - 0.2$			V

Note: 1.  $V_{IL}$  and  $V_{IH}$  max are reference only and are not tested.

## AC Characteristics (Preliminary – Subject to Change)

Applicable over recommended operating range from  $T_A = -40^{\circ}\text{C}$  to  $+85^{\circ}\text{C}$ ,  $V_{CC} = +2.7\text{V}$  to  $+3.6\text{V}$   
 $C_L = 1$  TTL Gate and  $30$  pF (unless otherwise noted).

Symbol	Parameter	Min	Typ	Max	Units
$f_{\text{SCK}}$	SCK Clock Frequency	0		20	MHz
$t_{\text{RI}}$	Input Rise Time			20	ns
$t_{\text{FI}}$	Input Fall Time			20	ns
$t_{\text{WH}}$	SCK High Time	20			ns
$t_{\text{WL}}$	SCK Low Time	20			ns
$t_{\text{CS}}$	$\overline{\text{CS}}$ High Time	25			ns
$t_{\text{CSS}}$	$\overline{\text{CS}}$ Setup Time	25			ns
$t_{\text{CSH}}$	$\overline{\text{CS}}$ Hold Time	25			ns
$t_{\text{SU}}$	Data In Setup Time	5			ns
$t_{\text{H}}$	Data In Hold Time	5			ns
$t_{\text{HD}}$	$\overline{\text{Hold}}$ Setup Time	15			ns
$t_{\text{CD}}$	$\overline{\text{Hold}}$ Hold Time	15			ns
$t_{\text{V}}$	Output Valid			20	ns
$t_{\text{HO}}$	Output Hold Time	0			ns
$t_{\text{LZ}}$	$\overline{\text{Hold}}$ to Output Low Z			200	ns
$t_{\text{HZ}}$	$\overline{\text{Hold}}$ to Output High Z			200	ns
$t_{\text{DIS}}$	Output Disable Time			100	ns
$t_{\text{EC}}$	Erase Cycle Time per Sector			1.0	s
$t_{\text{SR}}$	Status Register Write Cycle Time			60	ms
$t_{\text{BPC}}$	Byte Program Cycle Time <sup>(1)</sup>		30	50	$\mu\text{s}$
Endurance <sup>(2)</sup>			10K		Write Cycles <sup>(3)</sup>

- Notes:
1. The programming time for  $n$  bytes will be equal to  $n \times t_{\text{BPC}}$ .
  2. This parameter is characterized at  $3.0\text{V}$ ,  $25^{\circ}\text{C}$  and is not 100% tested.
  3. One write cycle consists of erasing a sector, followed by programming the same sector.

## Serial Interface Description

**MASTER:** The device that generates the serial clock.

**SLAVE:** Because the Serial Clock pin (SCK) is always an input, the AT25F4096 always operates as a slave.

**TRANSMITTER/RECEIVER:** The AT25F4096 has separate pins designated for data transmission (SO) and reception (SI).

**MSB:** The Most Significant Bit (MSB) is the first bit transmitted and received.

**SERIAL OP-CODE:** After the device is selected with  $\overline{CS}$  going low, the first byte will be received. This byte contains the op-code that defines the operations to be performed.

**INVALID OP-CODE:** If an invalid op-code is received, no data will be shifted into the AT25F4096, and the serial output pin (SO) will remain in a high impedance state until the falling edge of  $\overline{CS}$  is detected again. This will reinitialize the serial communication.

**CHIP SELECT:** The AT25F4096 is selected when the  $\overline{CS}$  pin is low. When the device is not selected, data will not be accepted via the SI pin, and the serial output pin (SO) will remain in a high impedance state.

**HOLD:** The  $\overline{HOLD}$  pin is used in conjunction with the  $\overline{CS}$  pin to select the AT25F4096. When the device is selected and a serial sequence is underway,  $\overline{HOLD}$  can be used to pause the serial communication with the master device without resetting the serial sequence. To pause, the  $\overline{HOLD}$  pin must be brought low while the SCK pin is low. To resume serial communication, the  $\overline{HOLD}$  pin is brought high while the SCK pin is low (SCK may still toggle during  $\overline{HOLD}$ ). Inputs to the SI pin will be ignored while the SO pin is in the high impedance state.

**WRITE PROTECT:** The 25F4096 has a write lockout feature that can be activated by asserting the write protect pin ( $\overline{WP}$ ). When the lockout feature is activated, locked-out sectors will be READ only. The write protect pin will allow normal read/write operations when held high. When the  $\overline{WP}$  is brought low and WPEN bit is "1", all write operations to the status register are inhibited.  $\overline{WP}$  going low while  $\overline{CS}$  is still low will interrupt a write to the status register. If the internal status register write cycle has already been initiated,  $\overline{WP}$  going low will have no effect on any write operation to the status register. The  $\overline{WP}$  pin function is blocked when the WPEN bit in the status register is "0". This will allow the user to install the AT25F4096 in a system with the  $\overline{WP}$  pin tied to ground and still be able to write to the status register. All  $\overline{WP}$  pin functions are enabled when the WPEN bit is set to "1".

# SPI Serial Interface

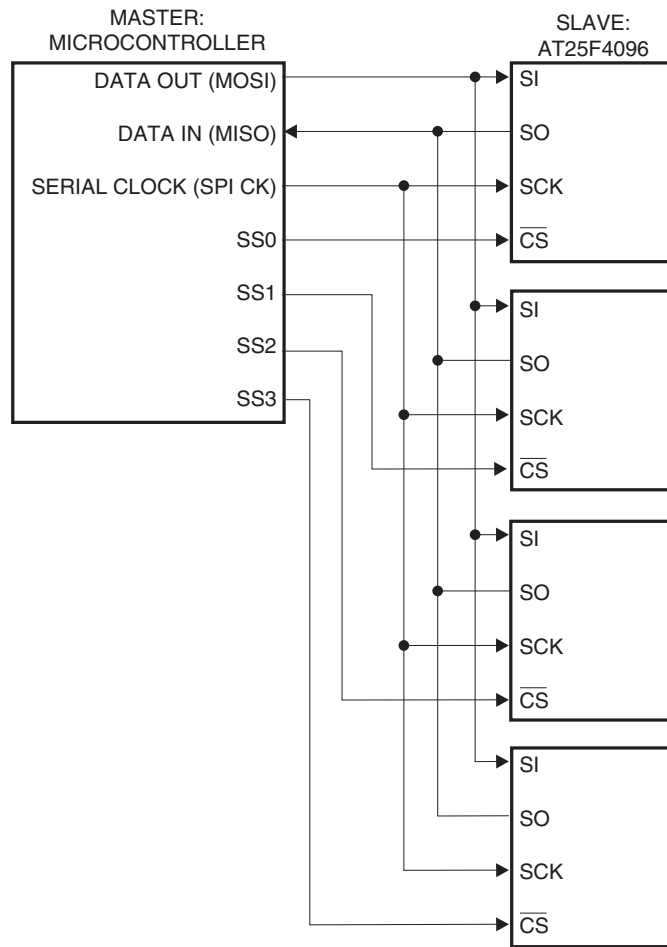

## Functional Description

The AT25F4096 is designed to interface directly with the synchronous serial peripheral interface (SPI) of the 6800 type series of microcontrollers.

The AT25F4096 utilizes an 8-bit instruction register. The list of instructions and their operation codes are contained in Table 1. All instructions, addresses, and data are transferred with the MSB first and start with a high-to-low transition.

Write is defined as program and/or erase in this specification. The following commands, PROGRAM, SECTOR ERASE, CHIP ERASE, and WRSR are write instructions for AT25F4096.

**Table 1.** Instruction Set for the AT25F4096

Instruction Name	Instruction Format	Operation
WREN	0000 X110	Set Write Enable Latch
WRDI	0000 X100	Reset Write Enable Latch
RDSR	0000 X101	Read Status Register
WRSR	0000 X001	Write Status Register
READ	0000 X011	Read Data from Memory Array
PROGRAM	0000 X010	Program Data Into Memory Array
SECTOR ERASE	0101 X010	Erase One Sector in Memory Array
CHIP ERASE	0110 X010	Erase All Sectors in Memory Array
RDID	0001 X101	Read Manufacturer and Product ID

**WRITE ENABLE (WREN):** The device will power up in the write disable state when  $V_{CC}$  is applied. All write instructions must therefore be preceded by the WREN instruction.

**WRITE DISABLE (WRDI):** To protect the device against inadvertent writes, the WRDI instruction disables all write commands. The WRDI instruction is independent of the status of the  $\overline{WP}$  pin.

**READ STATUS REGISTER (RDSR):** The RDSR instruction provides access to the status register. The READY/BUSY and write enable status of the device can be determined by the RDSR instruction. Similarly, the Block Write Protection bits indicate the extent of protection employed. These bits are set by using the WRSR instruction. During internal write cycles, all other commands will be ignored except the RDSR instruction.

**Table 2.** Status Register Format

Bit 7	Bit 6	Bit 5	Bit 4	Bit 3	Bit 2	Bit 1	Bit 0
WPEN	X	X	BP2	BP1	BP0	WEN	$\overline{RDY}$



**Table 3.** Read Status Register Bit Definition

Bit	Definition
Bit 0 ( $\overline{\text{RDY}}$ )	Bit 0 = 0 ( $\overline{\text{RDY}}$ ) indicates the device is READY. Bit 0 = 1 indicates the write cycle is in progress.
Bit 1 (WEN)	Bit 1 = 0 indicates the device <i>is not</i> WRITE ENABLED. Bit 1 = 1 indicates the device is WRITE ENABLED.
Bit 2 (BP0)	See Table 4.
Bit 3 (BP1)	See Table 4.
Bit 4 (BP2)	See Table 4.
Bits 5-6 are 0s when device is not in an internal write cycle.	
Bit 7 (WPEN)	See Table 5.
Bits 0-7 are 1s during an internal write cycle.	

**READ PRODUCT ID (RDID):** The RDID instruction allows the user to read the manufacturer and product ID of the device. The first byte after the instruction will be the manufacturer code (1FH = ATMEL), followed by the device code 64H.

**WRITE STATUS REGISTER (WRSR):** The WRSR instruction allows the user to select one of five levels of protection for the AT25F4096. The AT25F4096 is divided into eight sectors where the top 1/8, top quarter (1/4), top half (1/2), or all of the memory sectors can be protected (locked out) from write. Any of the locked-out sectors will therefore be READ only. The locked-out sector and the corresponding status register control bits are shown in Table 4.

The four bits, BP0, BP1, BP2 and WPEN, are nonvolatile cells that have the same properties and functions as the regular memory cells (e.g., WREN,  $t_{WC}$ , RDSR).

**Table 4.** Block Write Protect Bits

Level	Status Register Bits			AT25F4096	
	BP2	BP1	BP0	Array Addresses Locked Out	Locked-out Sector(s)
0(none)	0	0	0	None	None
1(1/8)	0	0	1	070000 - 07FFFF	Sector 8
2(1/4)	0	1	0	060000 - 07FFFF	Sector 7, 8
3(1/2)	0	1	1	040000 - 07FFFF	Sector 5, 6, 7, 8
4(all)	1	x	x	000000 - 07FFFF	All sectors (1 - 8)

Note: 1. x = don't care

The WRSR instruction also allows the user to enable or disable the Write Protect ( $\overline{\text{WP}}$ ) pin through the use of the Write Protect Enable (WPEN) bit. Hardware write protection is enabled when the  $\overline{\text{WP}}$  pin is low and the WPEN bit is "1". Hardware write protection is disabled when either the  $\overline{\text{WP}}$  pin is high or the WPEN bit is "0." When the device is hardware write protected, writes to the Status Register, including the Block Protect bits and the WPEN bit, and the locked-out sectors in the memory array are disabled. Write is only allowed to sectors of the memory which are not locked out. The WRSR instruction is self-timed to automatically erase and program BP0, BP1, BP2 and WPEN bits. In

order to write the status register, the device must first be write enabled via the WREN instruction. Then, the instruction and data for the four bits are entered. During the internal write cycle, all instructions will be ignored except RDSR instructions. The AT25F4096 will automatically return to write disable state at the completion of the WRSR cycle.

Note: When the WPEN bit is hardware write protected, it cannot be changed back to “0”, as long as the  $\overline{WP}$  pin is held low.

**Table 5.** WPEN Operation

WPEN	WP	WEN	ProtectedBlocks	UnprotectedBlocks	Status Register
0	X	0	Protected	Protected	Protected
0	X	1	Protected	Writable	Writable
1	Low	0	Protected	Protected	Protected
1	Low	1	Protected	Writable	Protected
X	High	0	Protected	Protected	Protected
X	High	1	Protected	Writable	Writable

**READ (READ):** Reading the AT25F4096 via the SO (Serial Output) pin requires the following sequence. After the  $\overline{CS}$  line is pulled low to select a device, the READ instruction is transmitted via the SI line followed by the byte address to be read (Refer to Table 6). Upon completion, any data on the SI line will be ignored. The data (D7-D0) at the specified address is then shifted out onto the SO line. If only one byte is to be read, the  $\overline{CS}$  line should be driven high after the data comes out. The READ instruction can be continued since the byte address is automatically incremented and data will continue to be shifted out of the AT25F4096 until the highest address is reached, the address counter will roll over to the lowest address allowing the entire memory to be read in one continuous READ instruction.

**PROGRAM (PROGRAM):** In order to program the AT25F4096, two separate instructions must be executed. First, the device must be write enabled via the WREN instruction. Then the PROGRAM instruction can be executed. Also, the address of the memory location(s) to be programmed must be outside the protected address field location selected by the Block Write Protection Level. During an internal self-timed programming cycle, all commands will be ignored except the RDSR instruction.

The PROGRAM instruction requires the following sequence. After the  $\overline{CS}$  line is pulled low to select the device, the PROGRAM instruction is transmitted via the SI line followed by the byte address and the data (D7-D0) to be programmed (Refer to Table 6). Programming will start after the  $\overline{CS}$  pin is brought high. The low-to-high transition of the  $\overline{CS}$  pin must occur during the SCK low time immediately after clocking in the D0 (LSB) data bit.

The READY/BUSY status of the device can be determined by initiating a RDSR instruction. If Bit 0 = 1, the program cycle is still in progress. If Bit 0 = 0, the program cycle has ended. Only the RDSR instruction is enabled during the program cycle.

A single PROGRAM instruction programs 1 to 256 consecutive bytes within a page if it is not write protected. The starting byte could be anywhere within the page. When the end of the page is reached, the address will wrap around to the beginning of the same page. If the data to be programmed are less than a full page, the data of all other bytes on the same page will remain unchanged. If more than 256 bytes of data are provided, the address counter will roll over on the same page and the previous data provided will be replaced. The same byte cannot be reprogrammed without erasing the whole sector

first. The AT25F4096 will automatically return to the write disable state at the completion of the PROGRAM cycle.

Note: If the device is not write enabled (WREN), the device will ignore the Write instruction and will return to the standby state, when  $\overline{CS}$  is brought high. A new  $\overline{CS}$  falling edge is required to re-initiate the serial communication.

**Table 6.** Address Key

Address	AT25F4096
$A_N$	$A_{18} - A_0$
Dont' Care Bits	$A_{23} - A_{19}$

**SECTOR ERASE (SECTOR ERASE):** Before a byte can be reprogrammed, the sector which contains the byte must be erased. In order to erase the AT25F4096, two separate instructions must be executed. First, the device must be write enabled via the WREN instruction. Then the SECTOR ERASE instruction can be executed.

**Table 7.** Sector Addresses

Sector Address	AT25F4096 Sector
000000 to 00FFFF	Sector 1
010000 to 01FFFF	Sector 2
020000 to 02FFFF	Sector 3
030000 to 03FFFF	Sector 4
040000 to 04FFFF	Sector 5
050000 to 05FFFF	Sector 6
060000 to 06FFFF	Sector 7
070000 to 07FFFF	Sector 8

The SECTOR ERASE instruction erases every byte in the selected sector if the sector is not locked out. Sector address is automatically determined if any address within the sector is selected. The SECTOR ERASE instruction is internally controlled; it will automatically be timed to completion. During this time, all commands will be ignored, except RDSR instruction. The AT25F4096 will automatically return to the write disable state at the completion of the SECTOR ERASE cycle.

**CHIP ERASE (CHIP ERASE):** As an alternative to the SECTOR ERASE, the CHIP ERASE instruction will erase every byte in all sectors that are not locked out. First, the device must be write enabled via the WREN instruction. Then the CHIP ERASE instruction can be executed. The CHIP ERASE instruction is internally controlled; it will automatically be timed to completion. The CHIP ERASE cycle time typically is 8 seconds. During the internal erase cycle, all instructions will be ignored except RDSR. The AT25F4096 will automatically return to the write disable state at the completion of the CHIP ERASE cycle.

## Timing Diagrams (for SPI Mode 0 (0, 0))

### Synchronous Data Timing

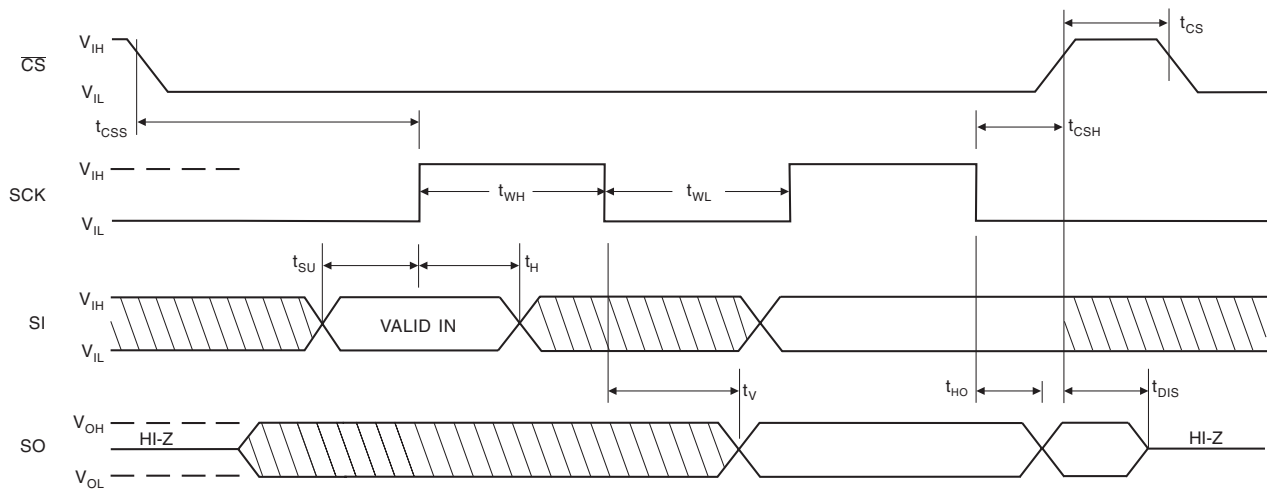

### WREN Timing

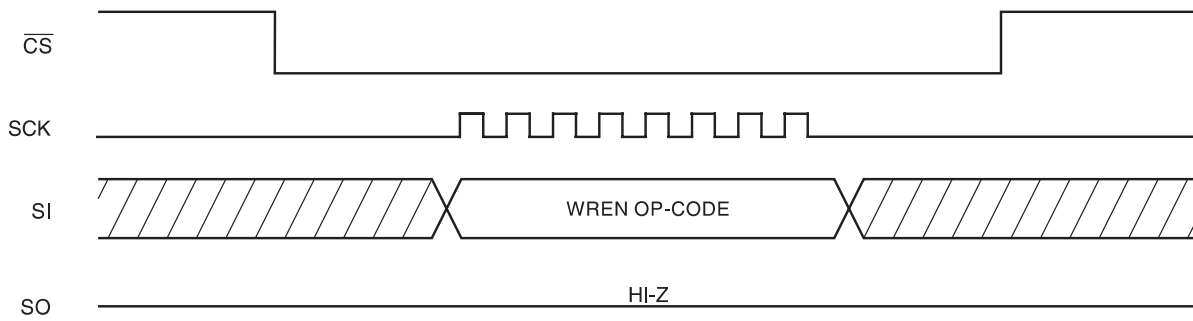

### WRDI Timing

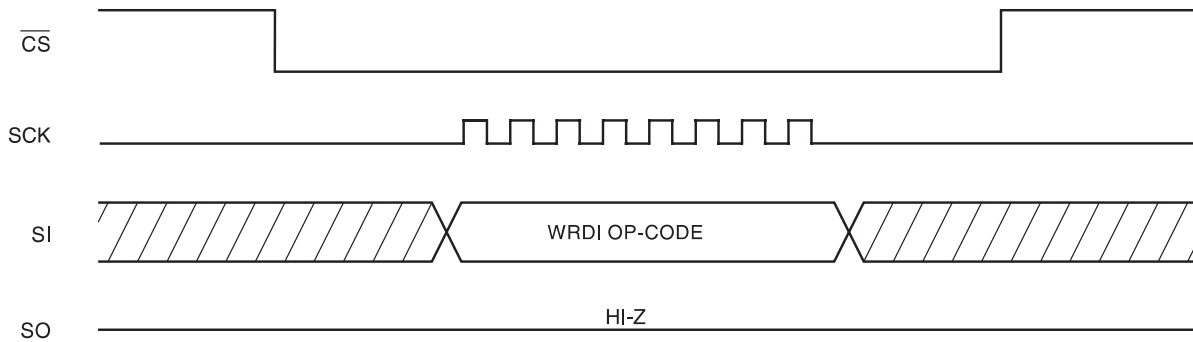

### RDSR Timing

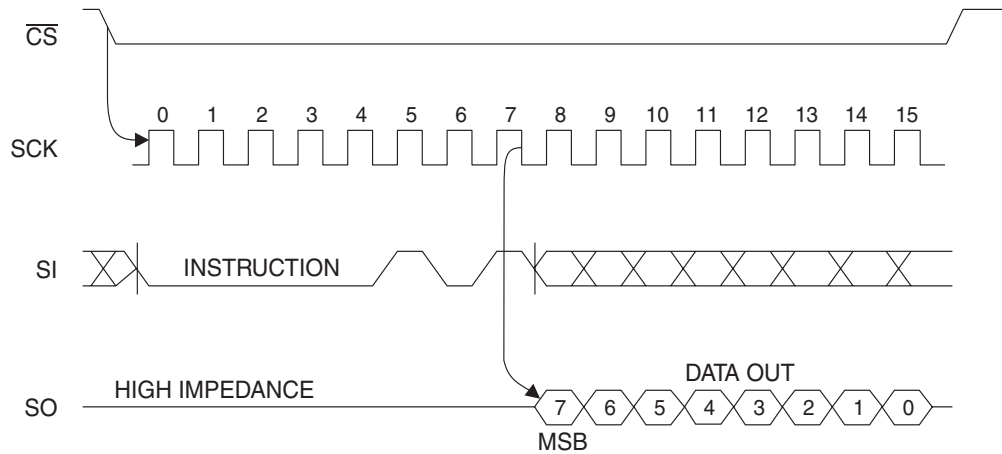

### WRSR Timing

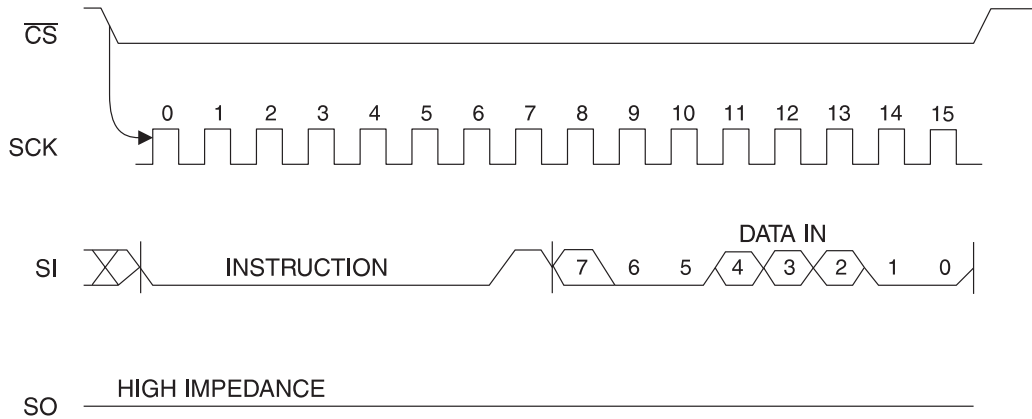

### READ Timing

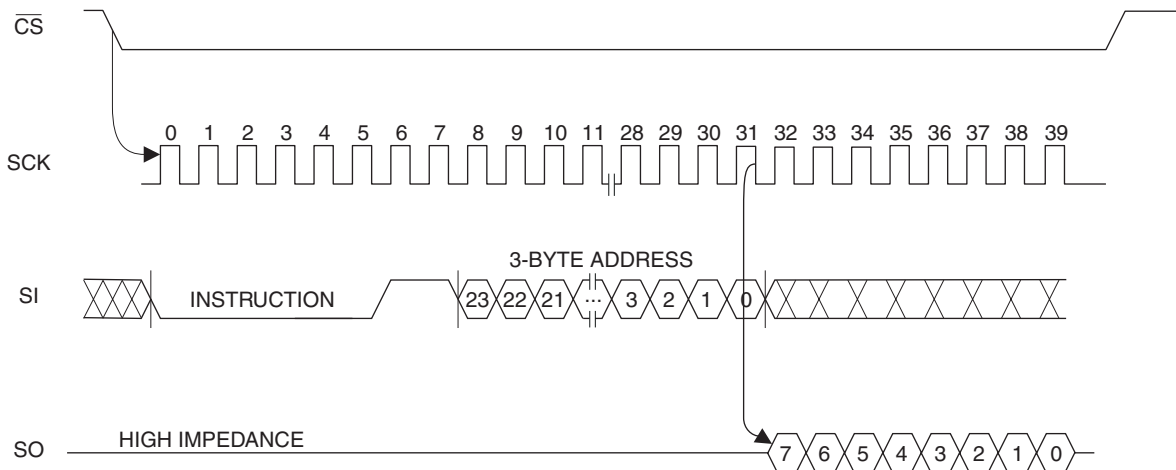

## PROGRAM Timing

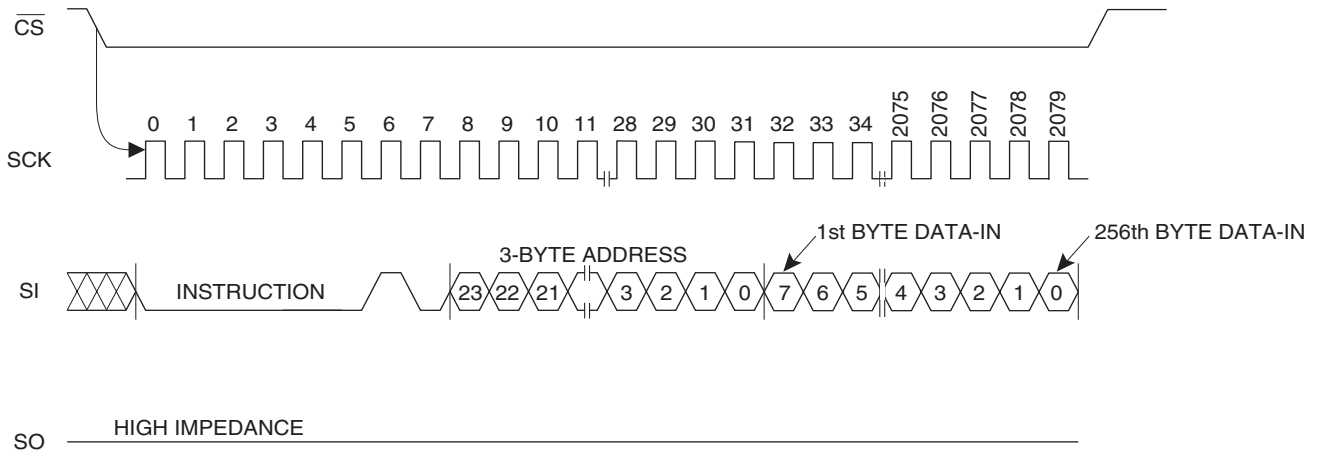

## HOLD Timing

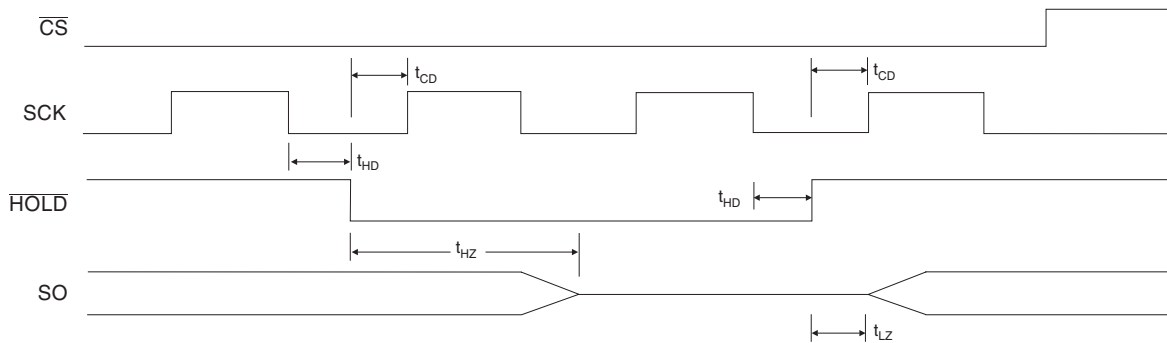

## SECTOR ERASE Timing

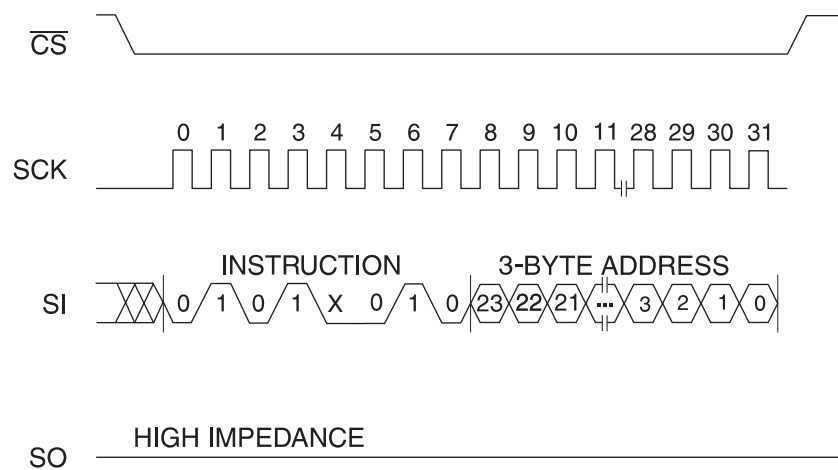

X = Don't Care bit

### CHIP ERASE Timing

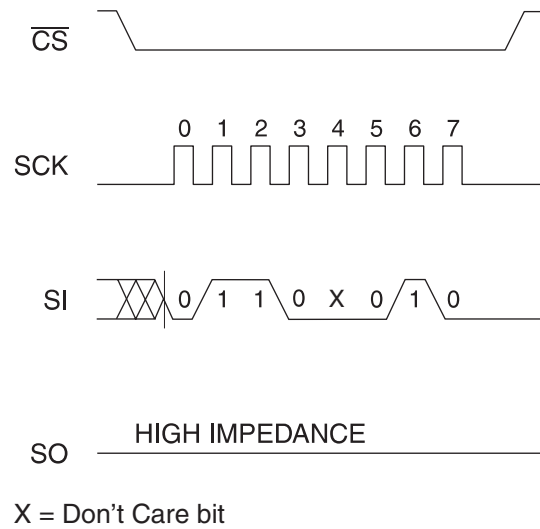

### RDID Timing

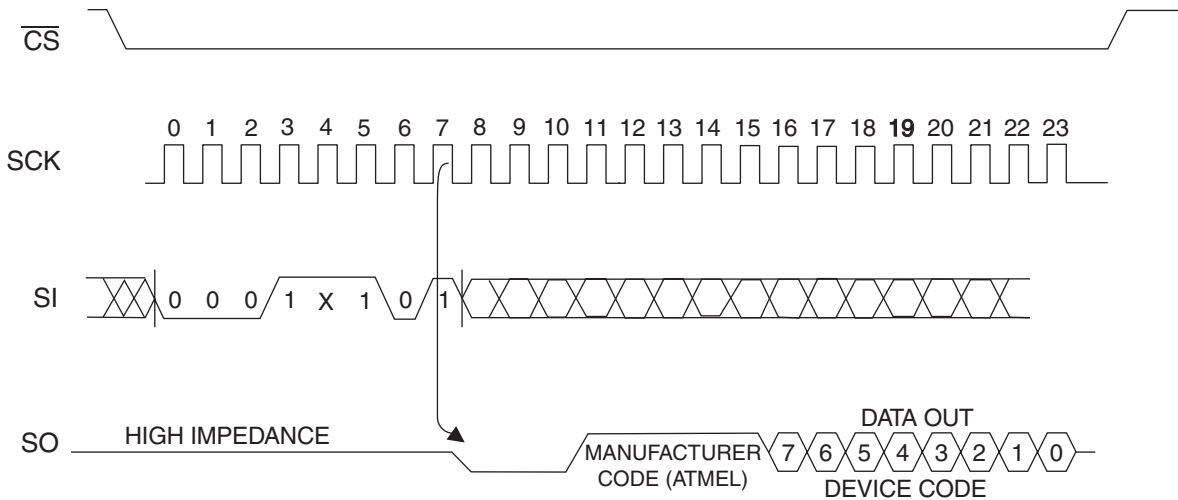

## Ordering Information

Ordering Code	Package	Operation Range
AT25F4096W-10SU-2.7	8S2	Lead-Free/Halogen-Free/ Industrial Temperature (-40°C to 85°C)

Package Type	
<b>8S2</b>	8-lead, 0.200" Wide, Plastic Gull Wing Small Outline Package (EIAJ SOIC)
Options	
<b>-2.7</b>	Low Voltage (2.7V to 3.6V)

# Package Information

## 8S2 – EIAJ SOIC

**Top View**

**End View**

**Side View**

**COMMON DIMENSIONS**  
(Unit of Measure = mm)

SYMBOL	MIN	NOM	MAX	NOTE
A	1.70		2.16	
A1	0.05		0.25	
b	0.35		0.48	5
C	0.15		0.35	5
D	5.13		5.35	
E1	5.18		5.40	2, 3
E	7.70		8.26	
L	0.51		0.85	
∅	0°		8°	
e	1.27 BSC			4

Notes: 1. This drawing is for general information only; refer to EIAJ Drawing EDR-7320 for additional information.  
 2. Mismatch of the upper and lower dies and resin burrs are not included.  
 3. It is recommended that upper and lower cavities be equal. If they are different, the larger dimension shall be regarded.  
 4. Determines the true geometric position.  
 5. Values b and C apply to pb/Sn solder plated terminal. The standard thickness of the solder layer shall be 0.010 +0.010/-0.005 mm.

10/7/03

2325 Orchard Parkway San Jose, CA 95131	<b>TITLE</b> <b>8S2</b> , 8-lead, 0.209" Body, Plastic Small Outline Package (EIAJ)	<b>DRAWING NO.</b> 8S2	<b>REV.</b> C
--------------------------------------------	-------------------------------------------------------------------------------------------	---------------------------	------------------



## Atmel Corporation

2325 Orchard Parkway  
San Jose, CA 95131, USA  
Tel: 1(408) 441-0311  
Fax: 1(408) 487-2600

## Regional Headquarters

### Europe

Atmel Sarl  
Route des Arsenalux 41  
Case Postale 80  
CH-1705 Fribourg  
Switzerland  
Tel: (41) 26-426-5555  
Fax: (41) 26-426-5500

### Asia

Room 1219  
Chinachem Golden Plaza  
77 Mody Road Tsimshatsui  
East Kowloon  
Hong Kong  
Tel: (852) 2721-9778  
Fax: (852) 2722-1369

### Japan

9F, Tonetsu Shinkawa Bldg.  
1-24-8 Shinkawa  
Chuo-ku, Tokyo 104-0033  
Japan  
Tel: (81) 3-3523-3551  
Fax: (81) 3-3523-7581

## Atmel Operations

### Memory

2325 Orchard Parkway  
San Jose, CA 95131, USA  
Tel: 1(408) 441-0311  
Fax: 1(408) 436-4314

### Microcontrollers

2325 Orchard Parkway  
San Jose, CA 95131, USA  
Tel: 1(408) 441-0311  
Fax: 1(408) 436-4314

La Chantrerie  
BP 70602  
44306 Nantes Cedex 3, France  
Tel: (33) 2-40-18-18-18  
Fax: (33) 2-40-18-19-60

### ASIC/ASSP/Smart Cards

Zone Industrielle  
13106 Rousset Cedex, France  
Tel: (33) 4-42-53-60-00  
Fax: (33) 4-42-53-60-01

1150 East Cheyenne Mtn. Blvd.  
Colorado Springs, CO 80906, USA  
Tel: 1(719) 576-3300  
Fax: 1(719) 540-1759

Scottish Enterprise Technology Park  
Maxwell Building  
East Kilbride G75 0QR, Scotland  
Tel: (44) 1355-803-000  
Fax: (44) 1355-242-743

### RF/Automotive

Theresienstrasse 2  
Postfach 3535  
74025 Heilbronn, Germany  
Tel: (49) 71-31-67-0  
Fax: (49) 71-31-67-2340

1150 East Cheyenne Mtn. Blvd.  
Colorado Springs, CO 80906, USA  
Tel: 1(719) 576-3300  
Fax: 1(719) 540-1759

### Biometrics/Imaging/Hi-Rel MPU/ High Speed Converters/RF Datacom

Avenue de Rochepleine  
BP 123  
38521 Saint-Egreve Cedex, France  
Tel: (33) 4-76-58-30-00  
Fax: (33) 4-76-58-34-80

---

### Literature Requests

[www.atmel.com/literature](http://www.atmel.com/literature)

**Disclaimer:** Atmel Corporation makes no warranty for the use of its products, other than those expressly contained in the Company's standard warranty which is detailed in Atmel's Terms and Conditions located on the Company's web site. The Company assumes no responsibility for any errors which may appear in this document, reserves the right to change devices or specifications detailed herein at any time without notice, and does not make any commitment to update the information contained herein. No licenses to patents or other intellectual property of Atmel are granted by the Company in connection with the sale of Atmel products, expressly or by implication. Atmel's products are not authorized for use as critical components in life support devices or systems.

© Atmel Corporation 2004. All rights reserved. Atmel® and combinations thereof, are the registered trademarks of Atmel Corporation or its subsidiaries. Other terms and product names may be the trademarks of others.



Printed on recycled paper.

2454C-SEEPR-8/04