

Features

- Current-controlled Output Current Source, 3 Input Channels
- Low-power Consumption
- Output Current per Channel to 250 mA
- Total Output Current to 300 mA
- Rise Time 1.0 ns, Fall Time 1.1 ns
- On-chip RF Oscillator
- Control of Frequency and Swing by Use of 2 External Resistors
- Oscillator Frequency Range from 200 MHz to 500 MHz
- Oscillator Swing to 100 mA
- Single 5 V Power Supply
- Common Enable, Disable Input
- TTL/CMOS Control Signals
- Small SSO16 Package and QFN16 Package

Applications

- CD-RW Drives
- Writable Optical Drives

Description

The T0816 is a laser diode driver for the operation of a grounded laser diode for CD-RW drives. It includes three channels for three different optical power levels which are controlled by a separate IC. The read channel generates a continuous output level whereas channels 2 and 3 are provided as write channels with very fast switching speeds. Write current pulses are enabled when a 'low' signal is applied to the NE pins. All channels are summed together at the IOOUT pin. Each channel can contribute up to 250 mA to the total output current of up to 300 mA. A total gain of 100 (read channel), 250 (channel 2) and 150 (channel 3) are provided between each reference current input and the output. Although the reference inputs are current inputs voltage control is possible by using external resistors.

An on-chip RF oscillator is provided to reduce laser mode hopping noise during read mode. Frequency and swing can be set by two external resistors. Oscillation is enabled by a 'high' at the ENOSC pin. Complete output current and oscillator switch-off is achieved by a 'low' at the ENABLE input.

Figure 1. Block Diagram

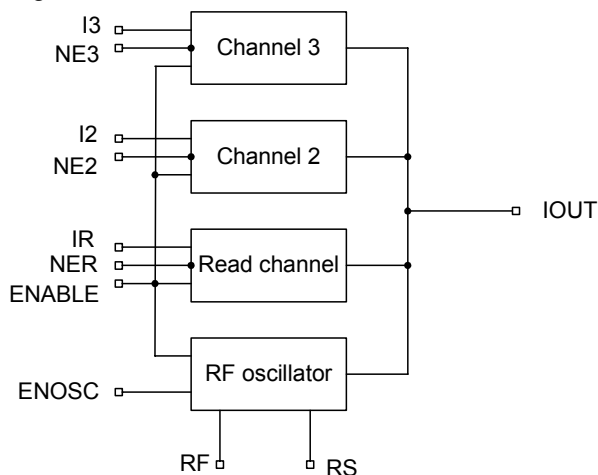

3-Channel Laser Driver with RF Oscillator

T0816



Pin Configuration

Figure 2. Pinning SSO16

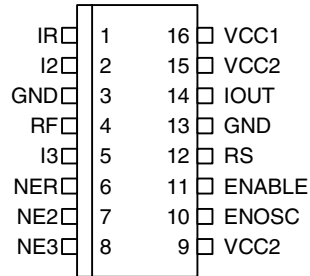

Pin Description: SSOP16

Pin	Symbol	Type	Function
1	IR	Analog	Input current, bias voltage approximately GND
2	I2	Analog	Input current, bias voltage approximately GND
3	GND	Supply	Ground
4	RF	Analog	External resistor to GND sets oscillator frequency
5	I3	Analog	Input current, bias voltage approximately GND
6	NER	Digital	Digital control of read channel (low active)
7	NE2	Digital	Digital control of channel 2 (low active)
8	NE3	Digital	Digital control of channel 3 (low active)
9	VCC2	Supply	+5 V power supply for IOOUT
10	ENOSC	Digital	Enables RF oscillator (high active)
11	ENABLE	Digital	Enables output current (high active)
12	RS	Analog	External resistor to GND sets oscillator swing
13	GND	Supply	Ground
14	IOOUT	Analog	Output current source for laser diode
15	VCC2	Supply	+5 V power supply for IOOUT
16	VCC1	Supply	+5 V power supply for circuit

Figure 3. Pinning QFN16

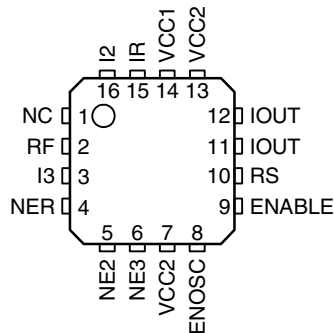

Pin Description: QFN16

Pin	Symbol	Type	Function
1	NC	–	Not connected
2	RF	Analog	External resistor to GND sets frequency of oscillator A
3	I3	Analog	Input current, bias voltage approximately GND
4	NER	Digital	Digital control of R channel (low active)
5	NE2	Digital	Digital control of channel 2 (low active)
6	NE3	Digital	Digital control of channel 3 (low active)
7	VCC2	Supply	+5 V power supply for IOU
8	ENOSC	Digital	Enables RF oscillator (high active)
9	ENABLE	Digital	Enables output current (high active)
10	RS	Analog	External resistor to GND sets oscillator swing
11,12	IOU	Analog	Output current source for laser diode
13	VCC2	Supply	+5 V power supply for IOU
14	VCC1	Supply	+5 V power supply for circuit
15	IR	Analog	Input current, bias voltage approximately GND
16	I2	Analog	Input current, bias voltage approximately GND
Paddle	GND	Supply	Ground

Absolute Maximum Ratings

Stresses beyond those listed under “Absolute Maximum Ratings” may cause permanent damage to the device. This is a stress rating only and functional operation of the device at these or any other conditions beyond those indicated in the operational sections of this specification is not implied. Exposure to absolute maximum rating conditions for extended periods may affect device reliability.

Parameters	Symbol	Value	Unit
Supply voltage	V_{CC}	-0.5 to +6.0	V
Input voltage at IR, I2, I3	V_{IN1}	-0.5 to + 2.0	V
Input voltage at NER, NE2, NE3, ENOSC	V_{IN2}	-0.5 to $V_{CC} + 0.5$	V
Output voltage	V_{OUT}	-0.5 to $V_{CC} - 1$	V
Power dissipation	P_{Max}	0.7 ⁽¹⁾ to 1 ⁽²⁾	W
Junction temperature	T_J	150	°C
Storage temperature range	T_{Stg}	-65 to +125	°C

Notes: 1. $R_{thJA} \leq 115$ K/W, $T_{amb} = 70^\circ\text{C}$
 2. $R_{thJA} \leq 115$ K/W, $T_{amb} = 25^\circ\text{C}$

Thermal Resistance

Parameters	Symbol	Value	Unit
Junction ambient	R_{thJA}	115 ⁽¹⁾	K/W

Note: 1. Measured with multi-layer test board (JEDEC standard)

Operating Range

Parameters	Symbol	Value	Unit
Supply voltage range	V_{CC}	4.5 to 5.5	V
Input current	I_{IR} I_{I2} I_{I3}	< 2.5 < 1.0 < 1.7	mA
External resistor to GND to set oscillator frequency	RF	> 3	k Ω
External resistor to GND to set oscillator swing	RS	> 1	k Ω
Operating temperature range	T_{amb}	0 to +70	°C

Electrical Characteristics: General

$V_{CC} = 5\text{ V}$, $T_{amb} = 25^{\circ}\text{C}$, ENABLE = High, NER = Low, NE2 = NE3 = High, ENOSC = Low, unless otherwise specified

No.	Parameters	Test Conditions	Pin ⁽¹⁾	Symbol	Min.	Typ.	Max.	Unit	Type*
1 Power Supply									
1.1	Supply current, power down	ENABLE = Low, NE2 = NE3 = Low	9; 15; 16	ICC_{PD2}		0.3		mA	A
1.2	Supply current, read mode, oscillator disabled	$I_{IR} = 500\ \mu\text{A}$, $I_{I2} = 200\ \mu\text{A}$, $I_{I3} = 333\ \mu\text{A}$	9; 15; 16	ICC_{R1}		86		mA	A
1.3	Supply current, read mode, oscillator enabled	$I_{IR} = 500\ \mu\text{A}$, $I_{I2} = 200\ \mu\text{A}$, $I_{I3} = 333\ \mu\text{A}$, ENOSC = High, RS = 7.5 k Ω , RF = 7.5 k Ω	9; 15; 16	ICC_{R2}		90		mA	A
1.4	Supply current, write mode	$I_{IR} = 500\ \mu\text{A}$, $I_{I2} = 200\ \mu\text{A}$, $I_{I3} = 333\ \mu\text{A}$, NE2 = NE3 = Low	9; 15; 16	ICC_W		175		mA	A
1.5	Supply current, input off	$I_{IR} = I_{I2} = I_{I3} = 0\ \mu\text{A}$	9; 15; 16	ICC_{off}		15		mA	A
2 Digital Inputs									
2.1	NER/NE2/NE3 low voltage		6, 7, 8	VNE_{LO}			1.3	V	A
2.2	NER/NE2/NE3 high voltage		6, 7, 8	VNE_{HI}	2.0			V	A
2.3	ENABLE low voltage		11	VEN_{LO}			0.5	V	A
2.4	ENABLE high voltage		11	VEN_{HI}	2.7			V	A
2.5	ENOSC low voltage		10	VEO_{LO}			0.5	V	A
2.6	ENOSC high voltage		10	VEO_{HI}	3.0			V	A
3 Current at Digital Inputs									
3.1	NER/NE2/NE3 low current	NE = 0 V	6, 7, 8	INE_{LO}	-300			μA	A
3.2	NER/NE2/NE3 high current	NE = 5 V	6, 7, 8	INE_{HI}			800	μA	A
3.3	ENABLE low current	ENABLE = 0 V	11	IEN_{LO}	-150			μA	A
3.4	ENABLE high current	ENABLE = 5 V	11	IEN_{HI}			100	μA	A
3.5	ENOSC low current	ENOSC = 0 V	10	IEO_{LO}	-100			μA	A
3.6	ENOSC high current	ENOSC = 5 V	10	IEO_{HI}			800	μA	A

*) Type means: A = 100% tested, B = 100% correlation tested, C = Characterized on samples, D = Design parameter

Note: 1. Related to SSO16 package.

Electrical Characteristics: Laser Amplifier

$V_{CC} = 5\text{ V}$, $T_{amb} = 25^\circ\text{C}$, ENABLE = High, unless otherwise specified

No.	Parameters	Test Conditions	Pin	Symbol	Min.	Typ.	Max.	Unit	Type*
4	Output IOU								
4.1	Total output current	Output is sourcing	14	I_{OUT}	300	350		mA	A
4.2	Output current per channel	Output is sourcing	14	I_{OUTR}	250			mA	A
4.5	I_{OUT} series resistance	Total R_{OUT} to V_{CC} rail	14	R_{OUT}		6		Ω	C
4.6	Best fit current gain I_R	Channel R ⁽¹⁾	14	GAINR	90	100	130	mA/mA	A
4.7	Best fit current gain I2	Channel 2 ⁽¹⁾	14	GAIN2	225	250	325	mA/mA	A
4.8	Best fit current gain I3	Channel 3 ⁽¹⁾	14	GAIN3	135	150	195	mA/mA	A
4.9	Best fit current offset	Any channel ⁽¹⁾	14	IOS	-8		+4	mA	A
4.10	Output current linearity	Any channel ⁽¹⁾	14	ILIN	-3		+3	%	A
4.11	I_{IN} input impedance	$R_{IN,IR}$ is to GND	1	$R_{IN,IR}$	400	500	600	Ω	A
4.12	I_{IN} input impedance	$R_{IN,I2}$ is to GND	2	$R_{IN,I2}$	1000	1250	1500	Ω	A
4.13	I_{IN} input impedance	$R_{IN,I3}$ is to GND	5	$R_{IN,I3}$	600	750	900	Ω	A
4.14	NE threshold	Temperature stabilized	6, 7, 8	VTH		1.68		V	B
4.15	Output off current 1	ENABLE = Low	14	IOFF ₁			1	mA	A
4.16	Output off current 2	NE2 = NE3 = High, $I_{IR} = 0$, $I_{I2} = 200\ \mu\text{A}$, $I_{I3} = 333\ \mu\text{A}$	14	IOFF ₂			1	mA	A
4.17	Output off current 3	NE2 = NE3 = Low, $I_{IR} = I_{I2} = I_{I3} = 0\ \mu\text{A}$	14	IOFF ₃			5	mA	A
4.18	I_{OUT} supply sensitivity, read mode	$I_{OUT} = 40\ \text{mA}$, $V_{CC} = 5\ \text{V} \pm 10\%$, read only	14	VSE _R	-4		1	%/V	A
4.19	I_{OUT} supply sensitivity, write mode	$I_{OUT} = 80\ \text{mA}$, 40 mA read + 40 mA write, $V_{CC} = 5\ \text{V} \pm 10\%$	14	VSE _W	-6		0	%/V	A
4.20	I_{OUT} current output noise	$I_{OUT} = 40\ \text{mA}$, ENOSC = Low	14	INO _O		3		nA/ rt-Hz	C
4.21	I_{OUT} temperature sensitivity, read mode	$I_{OUT} = 40\ \text{mA}$, read only	14	TSE _R		-400		ppm/ $^\circ\text{C}$	C
4.22	I_{OUT} temperature sensitivity, write mode	$I_{OUT} = 80\ \text{mA}$, 40 mA read + 40 mA write	14	TSE _W		-400		ppm/ $^\circ\text{C}$	C

*) Type means: A =100% tested, B = 100% correlation tested, C = Characterized on samples, D = Design parameter

Note: 1. Linearity of the amplifier is calculated using a best fit method at three operating points of I_{OUT} at 20 mA, 40 mA, and 60 mA. $I_{OUT} = (I_{IN} \times \text{GAIN}) + I_{OS}$

Electrical Characteristics: Laser Current Amplifier Outputs AC Performance

$V_{CC} = +5\text{ V}$, $I_{OUT} = 40\text{ mA}$ DC with 40 mA pulse, $T_{amb} = 25^\circ\text{C}$ unless otherwise specified

No.	Parameters	Test Conditions	Pin	Symbol	Min.	Typ.	Max.	Unit	Type*
5	Output AC Performance								
5.1	Write rise time	$I_{OUT} = 40\text{ mA (read) + 40 mA (10 to 90\%)}^{(1)}$	14	t_{RISE}		1.0	2.0	ns	C
5.2	Write fall time	$I_{OUT} = 40\text{ mA (read) + 40 mA (10 to 90\%)}^{(1)}$	14	t_{FALL}		1.1	2.0	ns	C
5.3	Output current overshoot	$I_{OUT} = 40\text{ mA (read) + 40 mA}^{(1)}$	14	OS		5		%	C
5.4	I_{OUT} ON propagation delay	NE 50% High-Low to I_{OUT} at 50% of final value	14	t_{ON}		2		ns	C
5.5	I_{OUT} OFF propagation delay	NE 50% Low-High to I_{OUT} at 50% of final value	14	t_{OFF}		2		ns	C
5.6	Disable time	ENABLE 50% High-Low to I_{OUT} at 50% of final value	14	t_{DIS}		20		ns	C
5.7	Enable time	ENABLE 50% Low-High to I_{OUT} at 50% of final value	14	t_{EN}		20		ns	C
5.8	Amplifier bandwidth	$I_{OUT} = 50\text{ mA}$, all channels, -3 dB value	14	BW_{LCA}		16		MHz	C
6	Oscillator								
6.1	Oscillator frequency	$R_F = 7.5\text{ k}\Omega$	14	F_{OSC}	270	300	330	MHz	A
6.2	Osc. temperature coefficient	$R_F = 7.5\text{ k}\Omega$	14	TC_{OSC}		-150		ppm/ $^\circ\text{C}$	C
6.3	Disable time oscillator	ENOSC 50% High-Low to I_{OUT} at 50% of final value	14	T_{DISO}		4		ns	C
6.4	Enable time oscillator	ENOSC 50% Low-High to I_{OUT} at 50% of final value	14	T_{ENO}		2		ns	C

*) Type means: A =100% tested, B = 100% correlation tested, C = Characterized on samples, D = Design parameter

Note: 1. Load resistor at I_{OUT} 6.8 Ω , measurement with 50- Ω oscilloscope and 39- Ω series resistor.

Characteristic Curves

Figure 4. Oscillator Frequency versus Resistor R_F ($R_S = 7.5 \text{ k}\Omega$)

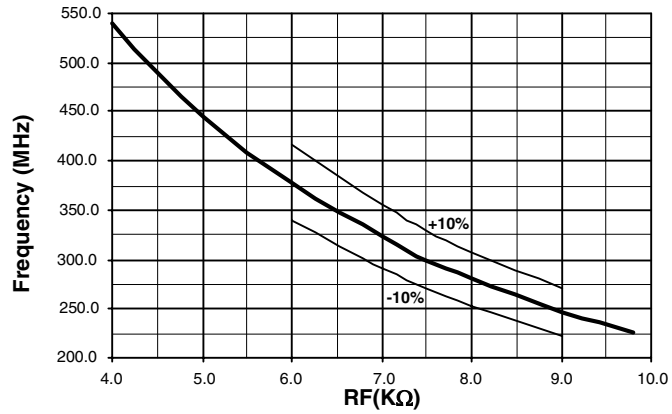

Figure 5. Oscillator Swing versus Resistor R_S ($R_F = 7.5 \text{ k}\Omega$)

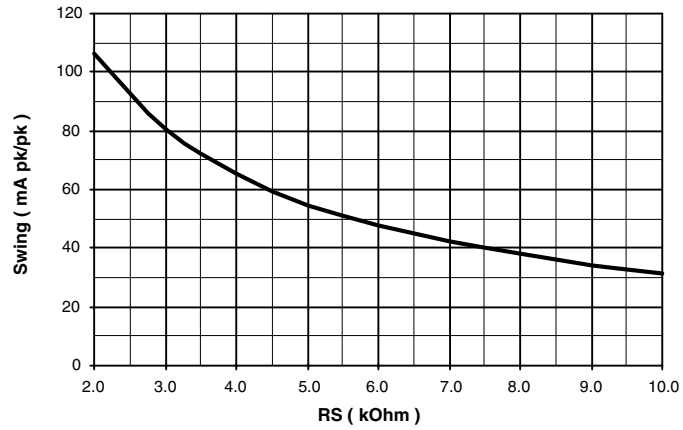

Figure 6. Oscillator Frequency Dependency of Swing

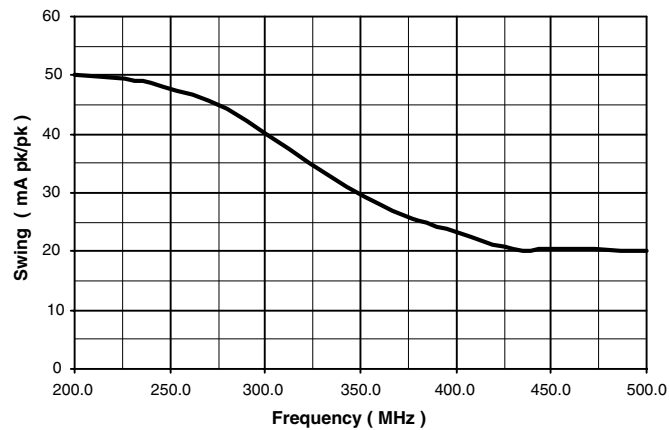

Figure 7. Transfer Characteristic of Channel 2
(Gain = 278, Load Resistor at IOOUT = 6.8 Ω)

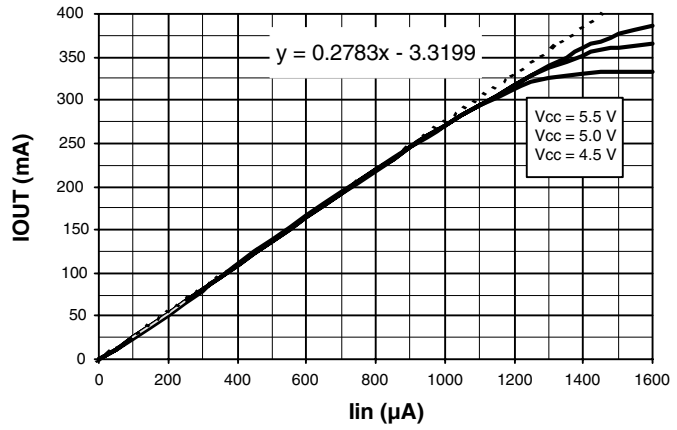

Figure 8. Voltage Compliance R (IOOUT to VCC) = 5.9 Ω

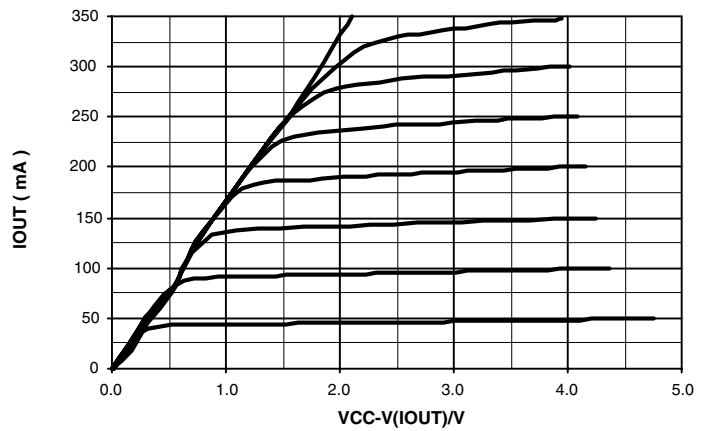

Figure 9. Step Response, Read Channel: 50 mA, Channel 2: 50 mApp

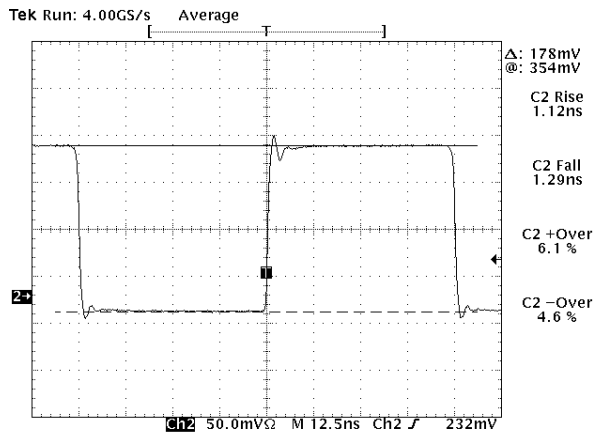

Figure 10. Step Response, Read Channel: 50 mA, Channel 2: 250 mApp

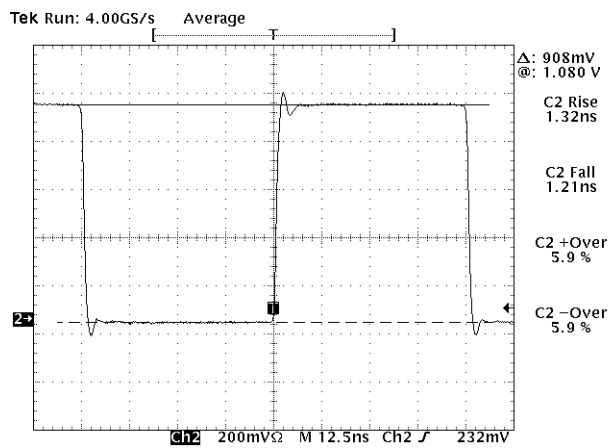

Figure 11. Timing Diagram of IOOUT

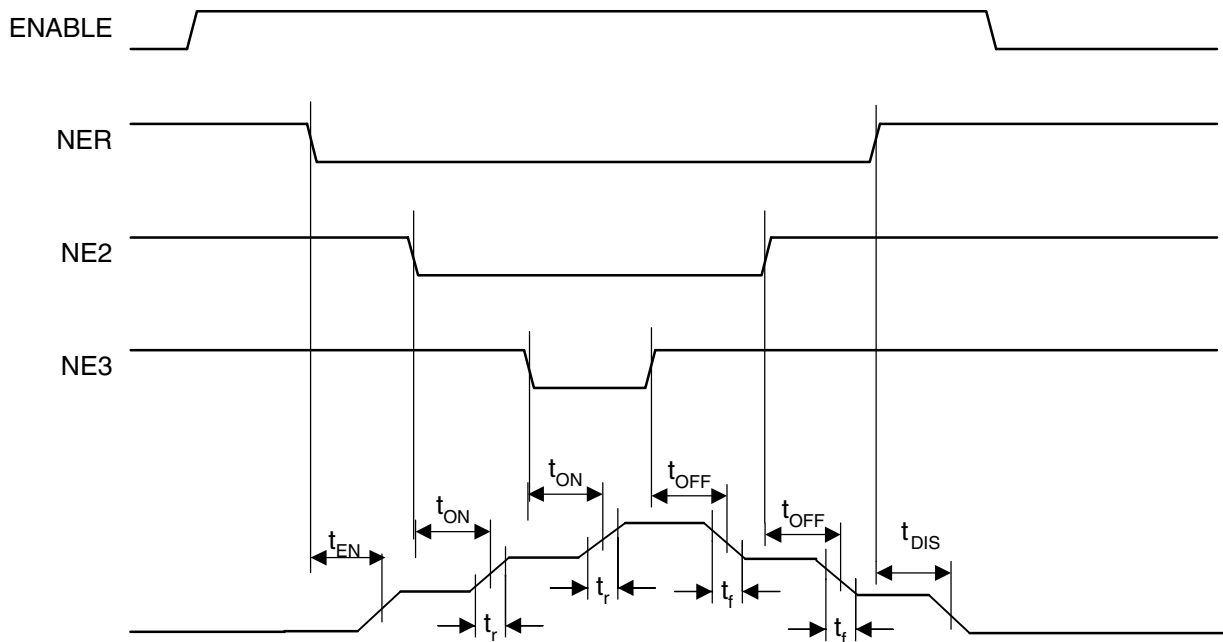
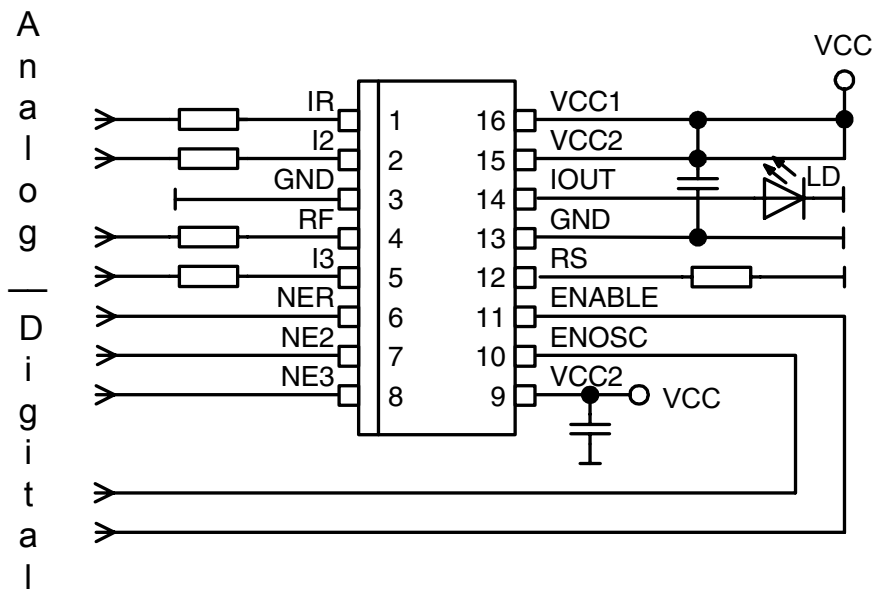

Figure 12. Application Circuit



Ordering Information

Extended Type Number	Package	Remarks
T0816-TCQ	SSO16	Taped and reeled
T0816M-TCQG	Pb-free SSO16	Taped and reeled
T0816-PEQG	Pb-free QFN16	Taped and reeled

Package Information

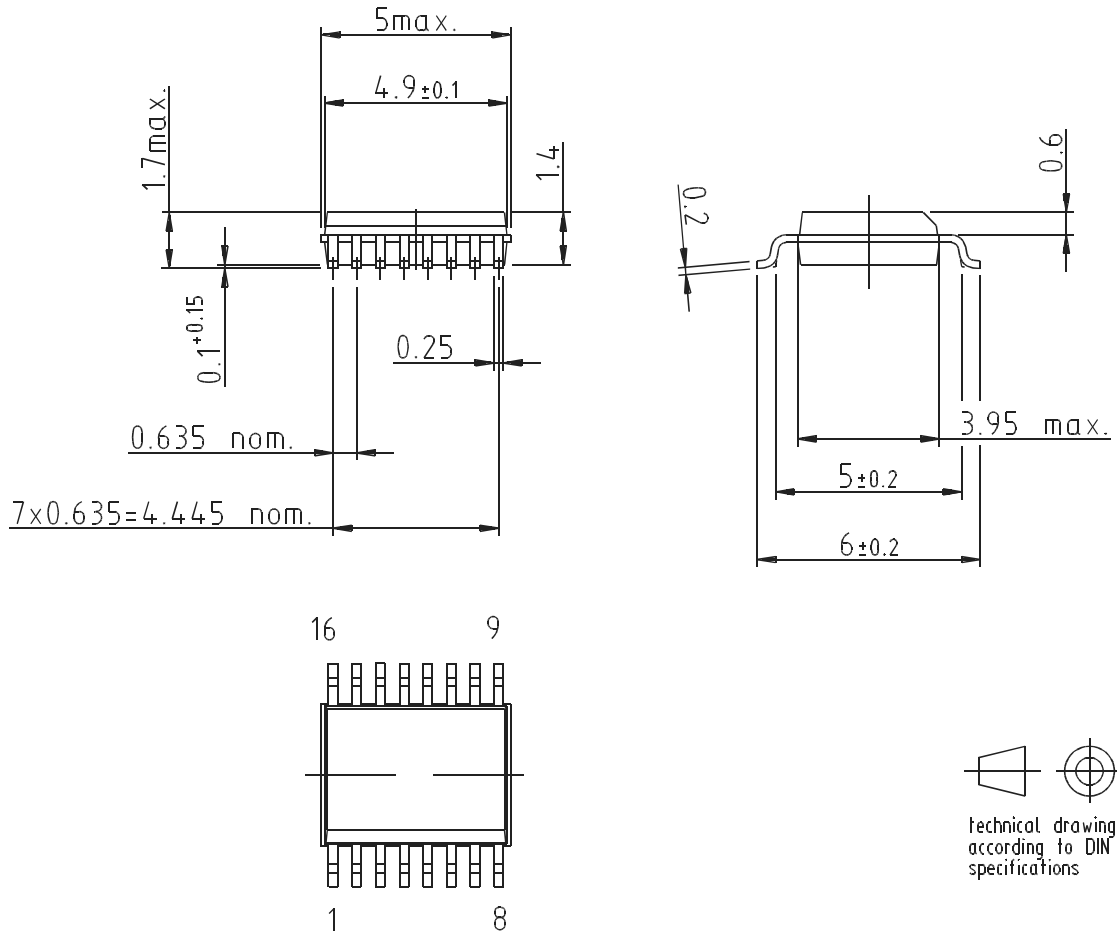

Drawing refers to following types: SSO16
 Package acc. JEDEC MO 137 AB

Drawing-No.: 6.543-5060.01-4
 Issue: 2; 05.02.99

Package: QFN 16 - 4x4
 Exposed pad 2.1x2.1
 (acc. JEDEC OUTLINE No. MO-220)
 Dimensions in mm

Not indicated tolerances ± 0.05

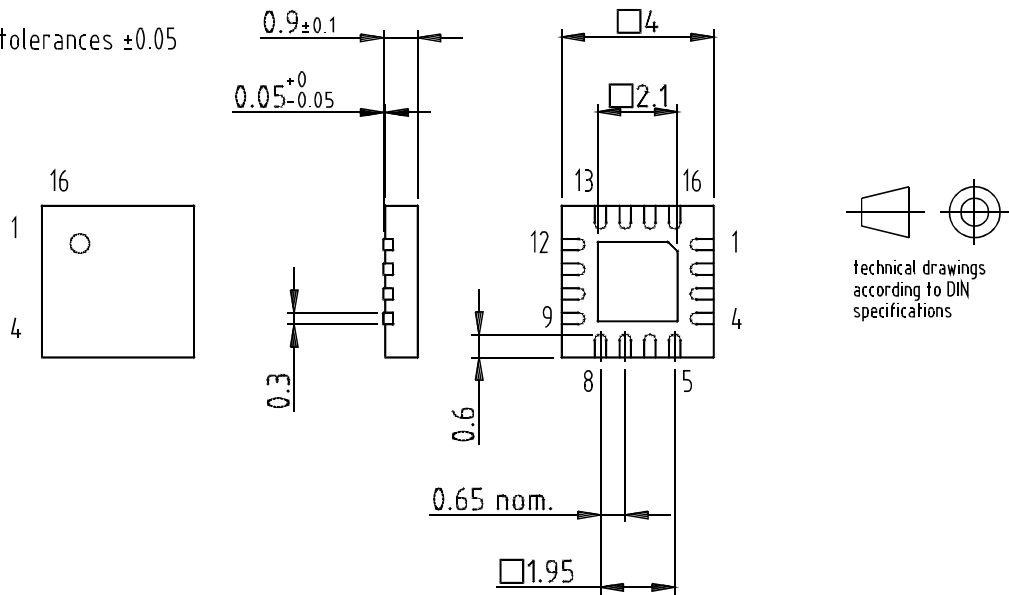

Drawing-No.: 6.543-5090.01-4
 Issue: 2; 24.01.03



Atmel Corporation

2325 Orchard Parkway
San Jose, CA 95131, USA
Tel: 1(408) 441-0311
Fax: 1(408) 487-2600

Regional Headquarters

Europe

Atmel Sarl
Route des Arsenalux 41
Case Postale 80
CH-1705 Fribourg
Switzerland
Tel: (41) 26-426-5555
Fax: (41) 26-426-5500

Asia

Room 1219
Chinachem Golden Plaza
77 Mody Road Tsimshatsui
East Kowloon
Hong Kong
Tel: (852) 2721-9778
Fax: (852) 2722-1369

Japan

9F, Tonetsu Shinkawa Bldg.
1-24-8 Shinkawa
Chuo-ku, Tokyo 104-0033
Japan
Tel: (81) 3-3523-3551
Fax: (81) 3-3523-7581

Atmel Operations

Memory

2325 Orchard Parkway
San Jose, CA 95131, USA
Tel: 1(408) 441-0311
Fax: 1(408) 436-4314

Microcontrollers

2325 Orchard Parkway
San Jose, CA 95131, USA
Tel: 1(408) 441-0311
Fax: 1(408) 436-4314

La Chantrerie
BP 70602
44306 Nantes Cedex 3, France
Tel: (33) 2-40-18-18-18
Fax: (33) 2-40-18-19-60

ASIC/ASSP/Smart Cards

Zone Industrielle
13106 Rousset Cedex, France
Tel: (33) 4-42-53-60-00
Fax: (33) 4-42-53-60-01

1150 East Cheyenne Mtn. Blvd.
Colorado Springs, CO 80906, USA
Tel: 1(719) 576-3300
Fax: 1(719) 540-1759

Scottish Enterprise Technology Park
Maxwell Building
East Kilbride G75 0QR, Scotland
Tel: (44) 1355-803-000
Fax: (44) 1355-242-743

RF/Automotive

Theresienstrasse 2
Postfach 3535
74025 Heilbronn, Germany
Tel: (49) 71-31-67-0
Fax: (49) 71-31-67-2340

1150 East Cheyenne Mtn. Blvd.
Colorado Springs, CO 80906, USA
Tel: 1(719) 576-3300
Fax: 1(719) 540-1759

Biometrics/Imaging/Hi-Rel MPU/ High Speed Converters/RF Datacom

Avenue de Rochepleine
BP 123
38521 Saint-Egreve Cedex, France
Tel: (33) 4-76-58-30-00
Fax: (33) 4-76-58-34-80

Literature Requests

www.atmel.com/literature

Disclaimer: Atmel Corporation makes no warranty for the use of its products, other than those expressly contained in the Company's standard warranty which is detailed in Atmel's Terms and Conditions located on the Company's web site. The Company assumes no responsibility for any errors which may appear in this document, reserves the right to change devices or specifications detailed herein at any time without notice, and does not make any commitment to update the information contained herein. No licenses to patents or other intellectual property of Atmel are granted by the Company in connection with the sale of Atmel products, expressly or by implication. Atmel's products are not authorized for use as critical components in life support devices or systems.

© Atmel Corporation 2003. All rights reserved.

Atmel® and combinations thereof are the registered trademarks of Atmel Corporation or its subsidiaries.

Other terms and product names may be the trademarks of others.



Printed on recycled paper.

4505G-DVD-09/03