

Features

- DC Characteristic Adjustable
- Receive Gain Adjustable
- Symmetrical Input of Microphone Amplifier
- Anti-clipping in Transmit Direction
- Automatic Line-loss Compensation
- Symmetrical Output of Earpiece Amplifier
- Built-in Ear Protection
- DTMF and MUTE Input
- Adjustable Sidetone Suppression Independent of Sending and Receiving Amplification
- Power Down
- Tone-ringer Interface
- 2-bit D/A for Volume Control
- Supply Voltages for All Functional Blocks of a Subscriber Set
- Operation Possible from 8-mA Line Currents

Applications

- Telephone Sets

Benefits

- Complete System Integration of Analog Signal Processing on One Chip
- Very Few External Components

Description

The microcontroller-controlled telephone circuit U4037B-N is a linear integrated circuit for use in telephone sets. It contains the speech circuit, tone-ringer interface, sidetone equivalent and ear-protection rectifiers. The circuit is line powered and contains all components necessary for amplification of signals and adaptation to the line.

Figure 1. Block Diagram

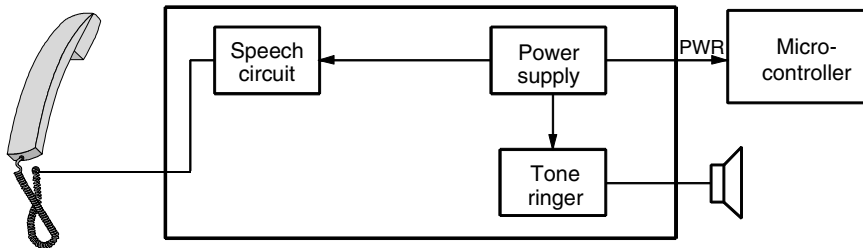

Microcontroller- controlled Speech and Ringer Circuit

U4037B-N

Pin Configuration

Figure 2. Pinning SO24

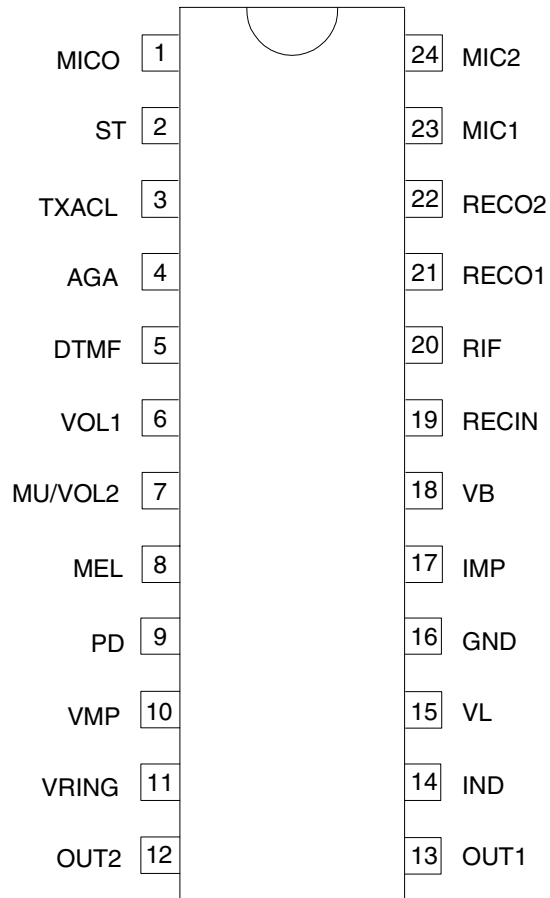

Pin Description

Pin	Symbol	Function
1	MICO	Output of microphone preamplifier
2	ST	Sidetone reduction input, input resistance is approximately 25 k Ω
3	TXACL	Time constant of anti-clipping in transmit path
4	AGA	Automatic gain adjustment with line current, a resistor connected from this pin to GND sets the starting point maximum gain change: 6 dB
5	DTMF	Input for DTMF signals
6	VOL1	2-bit volume adjustment for tone ringer
7	MU/VOL2	1) 2-bit volume adjustment for tone ringer 2) Mute of microphone amplifier: - Speech condition, input MU/VOL2 low - DTMF condition input MU/VOL2 high DTMF signal at pin 5 is fed to the line. A part of the DTMF signal is passed to the receiving amplifier as a confidence signal during dialing
8	MEL	Input for melody
9	PD	Active high input for reducing the current consumption of the circuit, V_L simultaneously is shorted by an internal switch
10	VMP	3.4 V regulated supply voltage for peripheral circuits (especially microprocessors), minimum output current: 2 mA (ringing), 4 mA (speech mode)
11	VRING	Input for ringer supply voltage
12	OUT2	Differential output for tone ringer
13	OUT1	
14	IND	The internal equivalent inductance of the circuit is proportional to the value of the capacitor at this pin, a resistor connected to ground may be used to reduce the DC line voltage
15	VL	Line voltage
16	GND	Reference point for DC- and AC-output signals
17	IMP	Impedance adjustment
18	VB	Unregulated supply voltage for peripheral circuits (voice switch), limited to typically 7 V
19	RECIN	Receiver input
20	RIF	Pin for adjustment of frequency response and gain of receiver
21	RECO1	Output of receiving amplifier
22	RECO2	Inverting output of receiving amplifier
23	MIC1	Inverting input of microphone amplifier
24	MIC2	Non-inverting input of microphone amplifier

Figure 3. Detailed Block Diagram with External Components

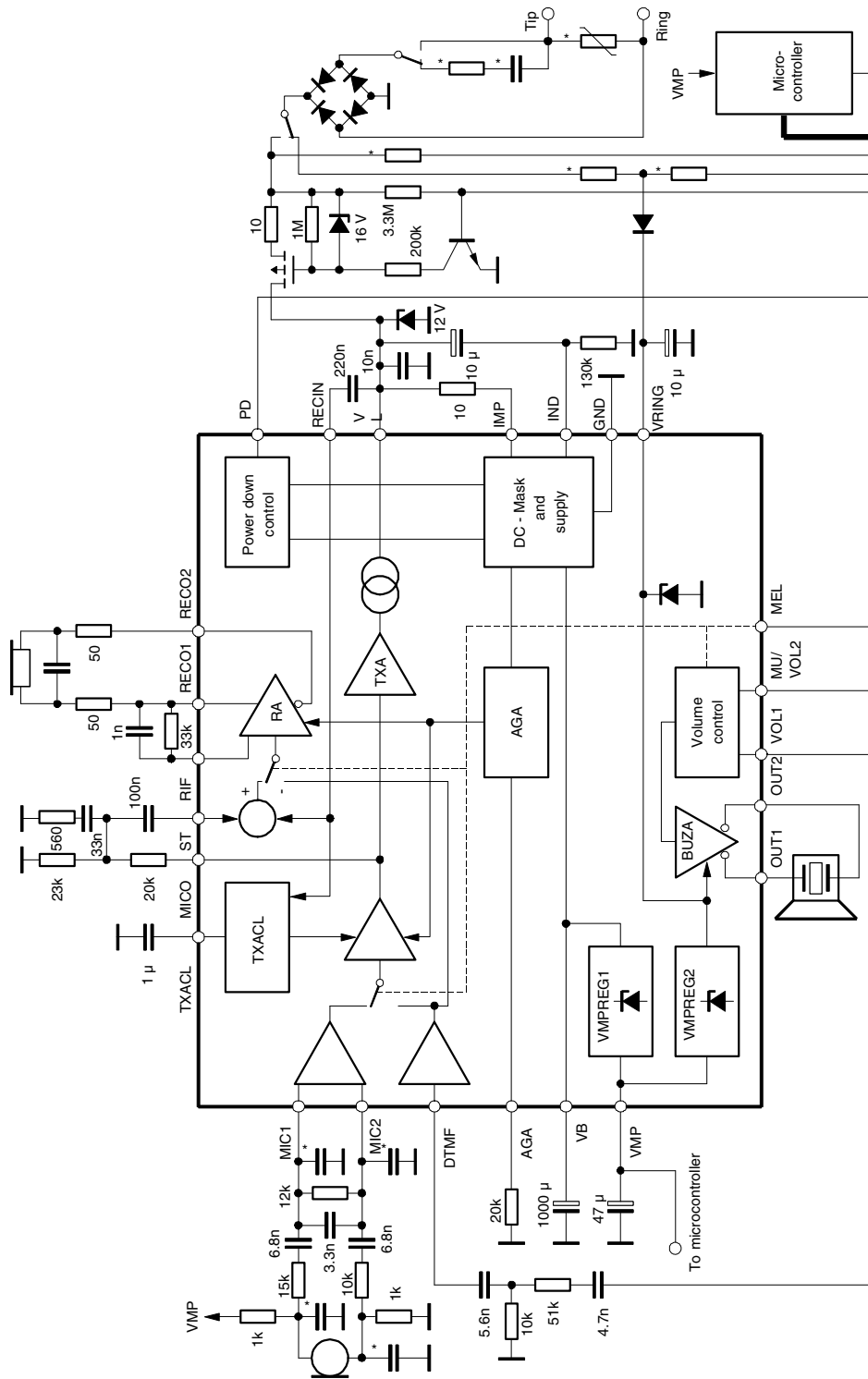

* Value depends on the application

Absolute Maximum Ratings

Stresses beyond those listed under “Absolute Maximum Ratings” may cause permanent damage to the device. This is a stress rating only and functional operation of the device at these or any other conditions beyond those indicated in the operational sections of this specification is not implied. Exposure to absolute maximum rating conditions for extended periods may affect device reliability.

Parameters	Symbol	Value	Unit
Line current	I_L	140	mA
DC line voltage	V_L	12	V
Maximum input current	I_{RING}	15	mA
Junction temperature	T_j	125	°C
Ambient temperature	T_{amb}	-25 to +75	°C
Storage temperature	T_{stg}	-55 to +150	°C
Total power dissipation, $T_{amb} = 60^\circ\text{C}$	P_{tot}	520	W

Thermal Resistance

Parameters	Symbol	Value	Unit
Junction ambient	R_{thJA}	75	K/W

Electrical Characteristics

$f = 1 \text{ kHz}$, $0 \text{ dBm} = 775 \text{ mV}_{rms}$, $I_{MP} = 2 \text{ mA}$, $T_{amb} = 25^\circ\text{C}$, $Z_{ear} = 68 \text{ nF} + 100 \Omega$, $Z_M = 68 \text{ nF}$, unless otherwise specified

Parameters	Test Conditions	Symbol	Min.	Typ.	Max.	Unit
DC Characteristics						
DC voltage drop over circuit	$I_L = 2 \text{ mA}$ $I_L = 14 \text{ mA}$ $I_L = 60 \text{ mA}$ $I_L = 100 \text{ mA}$	V_L	4.6 8.8	2.4 5.0 7.5 9.4	5.4 10.0	V
Transmission Amplifier, $I_L = 14 \text{ mA}$, $V_{MIC} = 2 \text{ mV}$, Unless Otherwise Specified						
Transmitting amplification		G_T	47	48	49	dB
Frequency response	$I_L \geq 14 \text{ mA}$ $f = 300 \text{ to } 3400 \text{ Hz}$	ΔG_T			± 0.5	dB
Gain change with current	$I_L = 14 \text{ to } 100 \text{ mA}$	ΔG_T			± 0.5	dB
Gain deviation	$T_{amb} = -10 \text{ to } +60^\circ\text{C}$	ΔG_T			± 0.5	dB
CMRR of microphone amplifier		CMRR	60	80		dB
Input resistance of MIC amplifier		R_i		50		k Ω
Distortion at line	$I_L > 14 \text{ mA}$ $V_L = 700 \text{ mV}_{rms}$	d_t			2	%
Maximum output voltage	$I_L > 19 \text{ mA}$, $d < 5\%$ $V_{MIC} = 10 \text{ mV}$ $CTXA = 1 \mu\text{F}$	V_{Lmax}	1.8	3	4.2	dBm
Noise at line psophometrically weighted	$I_L > 14 \text{ mA}$ $G_T = 48 \text{ dB}$	no		-80	-72	dBmp
Anti-clipping attack time release time	$CTXA = 1 \mu\text{F}$ each 3 dB overdrive			0.5 9		ms
Line-loss compensation	$I_L = 100 \text{ mA}$, $RAGA = 20 \text{ k}\Omega$	ΔG_{TI}	-6.4	-5.8	-5.2	dB

Electrical Characteristics (Continued)

$f = 1 \text{ kHz}$, $0 \text{ dBm} = 775 \text{ mV}_{\text{rms}}$, $I_{\text{MP}} = 2 \text{ mA}$, $T_{\text{amb}} = 25^\circ\text{C}$, $Z_{\text{ear}} = 68 \text{ nF} + 100 \Omega$, $Z_{\text{M}} = 68 \text{ nF}$, unless otherwise specified

Parameters	Test Conditions	Symbol	Min.	Typ.	Max.	Unit
Mute suppression	$I_{\text{L}} \geq 14 \text{ mA}$	G_{TM}	60	80		dB
Receiving Amplifier, $I_{\text{L}} = 14 \text{ mA}$, Unless Otherwise Specified, $V_{\text{GEN}} = 300 \text{ mV}$						
Receiving amplification		G_{R}			12	dB
Adjustment range		G_{R}	-8		12	dB
Amplification of DTMF signal from DTMF IN to RECO 1, 2	$I_{\text{L}} \geq 14 \text{ mA}$ $V_{\text{DTMF}} = 8 \text{ mV}$	G_{RM}	14		20	dB
Frequency response	$I_{\text{L}} > 14 \text{ mA}$ $f = 300 \text{ to } 3400 \text{ Hz}$	ΔG_{RF}			± 0.5	dB
Gain change with current	$I_{\text{L}} = 14 \text{ to } 100 \text{ mA}$	ΔG_{R}			± 0.5	dB
Gain deviation	$T_{\text{amb}} = -10 \text{ to } +60^\circ\text{C}$	ΔG_{R}			± 0.5	dB
Ear protection differential	$I_{\text{L}} \geq 14 \text{ mA}$ $V_{\text{GEN}} = 11 V_{\text{rms}}$	EP			2.2	V_{rms}
MUTE suppression	$I_{\text{L}} \geq 14 \text{ mA}$	ΔG_{R}	60			dB
Output voltage $d \leq 2\%$ differential	$I_{\text{L}} = 14 \text{ mA}$, $Z_{\text{ear}} = 68 \text{ nF} + 100 \Omega$		0.775			V_{rms}
Output voltage $d \leq 5\%$ differential	$I_{\text{L}} = 14 \text{ mA}$ $Z_{\text{ear}} = 68 \text{ nF} + 100 \Omega$ RDC = infinite		1.2			V_{rms}
Receiving noise psophometrically weighted	$Z_{\text{ear}} = 68 \text{ nF} + 100 \Omega$ $I_{\text{L}} \geq 14 \text{ mA}$	ni			-64	dBmp
Output resistance	Each output against GND	R_{o}			40	Ω
Line-loss compensation	RAGA = 20 k Ω $I_{\text{L}} = 100 \text{ mA}$	ΔG_{RI}	-7.0	-6.0	-5.0	dB
Gain at low operating current	$I_{\text{L}} = 8 \text{ mA}$, $I_{\text{MP}} = 1 \text{ mA}$ $I_{\text{M}} = 300 \mu\text{A}$ $V_{\text{GEN}} = 100 \text{ mV}$ RDC = 68 k Ω	G_{R}	10.5	12	13.5	dB
DTMF-amplifier Test Conditions: $I_{\text{MP}} = 2 \text{ mA}$						
DTMF amplification	$I_{\text{L}} = 15 \text{ mA}$ $V_{\text{DTMF}} = 8 \text{ mV}$ Mute active	G_{D}	40.7	41.7	42.7	dB
Gain deviation	$I_{\text{L}} = 15 \text{ mA}$ $T_{\text{amb}} = -10 \text{ to } +60^\circ\text{C}$	G_{D}			± 0.5	dB
Input resistance	RGT = 15 k Ω	R_{i}	15	20	25	k Ω
Distortion of DTMF signal	$I_{\text{L}} \geq 15 \text{ mA}$ $V_{\text{L}} = 0 \text{ dBm}$	d_{D}			2	%
Gain deviation with current	$I_{\text{L}} = 15 \text{ to } 100 \text{ mA}$	ΔG_{D}			± 0.5	dB
Supply Voltages, $V_{\text{MIC}} = 10 \text{ mV}$, $T_{\text{amb}} = -10 \text{ to } +60^\circ\text{C}$						
V_{MP}	$I_{\text{L}} = 8 \text{ mA}$ RDC = 130 k Ω $I_{\text{MP}} = 1 \text{ mA}$	V_{MP}	3.1	3.4	3.6	V
Ring Part, $I_{\text{VMP}} = 1 \text{ mA}$						
Maximum output voltage	$V_{\text{RING}} = 20 \text{ V}$	V_{out}		25		V_{pp}

Electrical Characteristics (Continued)

$f = 1 \text{ kHz}$, $0 \text{ dBm} = 775 \text{ mV}_{\text{rms}}$, $I_{\text{MP}} = 2 \text{ mA}$, $T_{\text{amb}} = 25^\circ\text{C}$, $Z_{\text{ear}} = 68 \text{ nF} + 100 \Omega$, $Z_{\text{M}} = 68 \text{ nF}$, unless otherwise specified

Parameters	Test Conditions	Symbol	Min.	Typ.	Max.	Unit
Input impedance in speech mode	$f = 300 \text{ Hz to } 3400 \text{ Hz}$ $I_{\text{L}} > 15 \text{ mA}$ $V_{\text{TIP/RING}} = 1.5 V_{\text{rms}}$	R_{i}	50			$\text{k}\Omega$
Ringing part: Ringer output voltage	$f = 25 \text{ Hz}$, $C_{\text{BUZ}} = 50 \text{ nF}$					
	$V_{\text{TIP/RING}} = 63 V_{\text{rms}}$	V_{out}	28			V_{pp}
	$V_{\text{TIP/RING}} = 45 V_{\text{rms}}$	V_{out}		18		V_{pp}
Volume adjustment steps		11		0		dB
		10		-6		
		01		-12		
		00		-24		
Zener diode voltage	$I_{\text{RING}} = 25 \text{ mA}$	V_{RINGmax}		28.5		V
PD Input						
PD input current	PD active, $I_{\text{L}} > 14 \text{ mA}$, $V_{\text{PD}} = V_{\text{MP}}$	I_{pd}		9		μA
Input voltage	PD = active PD = inactive	V_{pd} V_{pd}	2		0.3	V
Voltage drop at V_{L}	PD = active, $I_{\text{L}} = 14 \text{ mA}$ $I_{\text{L}} = 100 \text{ mA}$	V_{L}		1.5		V
		V_{L}		1.9		
Internal current consumption at V_{B}	$V_{\text{B}} = 3.5 \text{ V}$ PD = active, $I_{\text{L}} = 0 \text{ mA}$	I_{B}		300		μA

Ordering Information

Extended Type Number	Package	Remarks
U4037B-NFL	SO24	–
U4037B-NFLG3	SO24	Taped and reeled

Package Information

Package SO24

Dimensions in mm

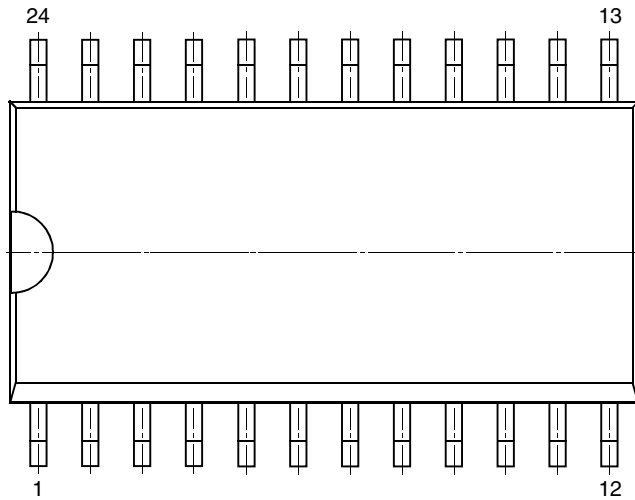
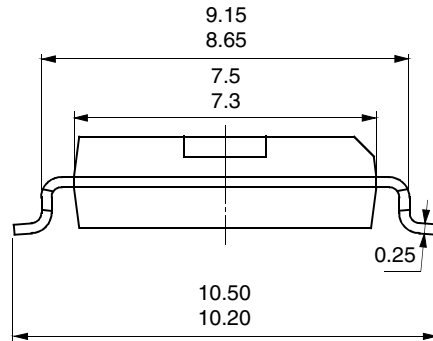
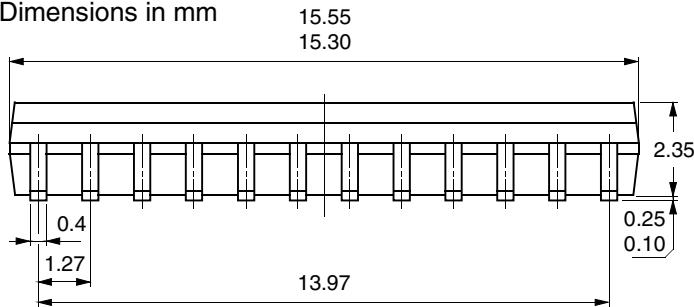

technical drawings
according to DIN
specifications



Atmel Corporation

2325 Orchard Parkway
San Jose, CA 95131, USA
Tel: 1(408) 441-0311
Fax: 1(408) 487-2600

Regional Headquarters

Europe

Atmel Sarl
Route des Arsenaux 41
Case Postale 80
CH-1705 Fribourg
Switzerland
Tel: (41) 26-426-5555
Fax: (41) 26-426-5500

Asia

Room 1219
Chinachem Golden Plaza
77 Mody Road Tsimshatsui
East Kowloon
Hong Kong
Tel: (852) 2721-9778
Fax: (852) 2722-1369

Japan

9F, Tonetsu Shinkawa Bldg.
1-24-8 Shinkawa
Chuo-ku, Tokyo 104-0033
Japan
Tel: (81) 3-3523-3551
Fax: (81) 3-3523-7581

Atmel Operations

Memory

2325 Orchard Parkway
San Jose, CA 95131, USA
Tel: 1(408) 441-0311
Fax: 1(408) 436-4314

Microcontrollers

2325 Orchard Parkway
San Jose, CA 95131, USA
Tel: 1(408) 441-0311
Fax: 1(408) 436-4314

La Chantrerie
BP 70602
44306 Nantes Cedex 3, France
Tel: (33) 2-40-18-18-18
Fax: (33) 2-40-18-19-60

ASIC/ASSP/Smart Cards

Zone Industrielle
13106 Rousset Cedex, France
Tel: (33) 4-42-53-60-00
Fax: (33) 4-42-53-60-01

1150 East Cheyenne Mtn. Blvd.
Colorado Springs, CO 80906, USA
Tel: 1(719) 576-3300
Fax: 1(719) 540-1759

Scottish Enterprise Technology Park
Maxwell Building
East Kilbride G75 0QR, Scotland
Tel: (44) 1355-803-000
Fax: (44) 1355-242-743

RF/Automotive

Theresienstrasse 2
Postfach 3535
74025 Heilbronn, Germany
Tel: (49) 71-31-67-0
Fax: (49) 71-31-67-2340

1150 East Cheyenne Mtn. Blvd.
Colorado Springs, CO 80906, USA
Tel: 1(719) 576-3300
Fax: 1(719) 540-1759

Biometrics/Imaging/Hi-Rel MPU/ High Speed Converters/RF Datacom

Avenue de Rochepleine
BP 123
38521 Saint-Egreve Cedex, France
Tel: (33) 4-76-58-30-00
Fax: (33) 4-76-58-34-80

Literature Requests

www.atmel.com/literature

Disclaimer: Atmel Corporation makes no warranty for the use of its products, other than those expressly contained in the Company's standard warranty which is detailed in Atmel's Terms and Conditions located on the Company's web site. The Company assumes no responsibility for any errors which may appear in this document, reserves the right to change devices or specifications detailed herein at any time without notice, and does not make any commitment to update the information contained herein. No licenses to patents or other intellectual property of Atmel are granted by the Company in connection with the sale of Atmel products, expressly or by implication. Atmel's products are not authorized for use as critical components in life support devices or systems.

© Atmel Corporation 2003. All rights reserved.

Atmel® and combinations thereof are the registered trademarks of Atmel Corporation or its subsidiaries.

Other terms and product names may be the trademarks of others.



Printed on recycled paper.

4742A-CORD-09/03