



Ambassador™ T8100A, T8102, and T8105 H.100/H.110 Interface and Time-Slot Interchangers

Introduction

This advisory describes a flaw in some devices that the initial factory test program did not detect. The flaw exists in some version 2 and version 3 T8100A, T8102, and T8105 devices in both the SQFP and BGA package types. An enhanced factory test program has been in place since January 2000, and all devices shipped after this date are good devices.

Problem: Data Memory Error

An error in the CAM data memories may cause the corruption of stream data bits and/or bytes. The problem may also occur in the microprocessor read path. Stream data may have an occasional '0' that should be a '1'. An entire bad byte may also occur. The problem going away with lower V_{DD} is a prime indicator of this problem. Not all devices are bad.

Workaround

There is no workaround for this flaw.

Corrective Action

Version 2 and version 3 devices that have the second line of markings ending with W01, W02, W03, W04, W05, W06, W07, W08, and W09 may be returned through Lucent's return material authorization (RMA) process for replacement or credit. Devices that have the second line of markings ending with W10, W11, and W12 are known good devices and do not have to be returned. To return devices, contact your sales person for an RMA number. Enter the RMA number within the following return address:

Lucent Technologies
Christa Bromfield
RMA # _____
555 Union Blvd., Rm. 31L-30R BU
Allentown, PA 18103

Explanation of Version Markings

The three versions can be identified by markings on the device and apply to the T8100A, T8102, and T8105.

Version 1

If there are only seven digits on the last line of the device code marking, and there is not an S following the 4-digit date code, the device is version 1 and applies to both the SQFP and BGA package types.

Version 2

1. If there are seven digits on the last line of the device code followed by a space and the letters V2, the device is version 2; or
2. If there is an S following the 4-digit date code on line 2, the device is version 2. This marking applies to both SQFP and BGA package types.

Version 3

1. For the BGA package type, if the first line ends in BAL3, the device is version 3; or
2. For the SQFP package type, if the first line ends in SC3, the device is version 3.

For additional information, contact your Microelectronics Group Account Manager or the following:

INTERNET: <http://www.lucent.com/micro>

E-MAIL: docmaster@micro.lucent.com

N. AMERICA: Microelectronics Group, Lucent Technologies Inc., 555 Union Boulevard, Room 30L-15P-BA, Allentown, PA 18103

1-800-372-2447, FAX 610-712-4106 (In CANADA: **1-800-553-2448**, FAX 610-712-4106)

ASIA PACIFIC: Microelectronics Group, Lucent Technologies Singapore Pte. Ltd., 77 Science Park Drive, #03-18 Cintech III, Singapore 118256

Tel. (65) 778 8833, FAX (65) 777 7495

CHINA: Microelectronics Group, Lucent Technologies (China) Co., Ltd., A-F2, 23/F, Zao Fong Universe Building, 1800 Zhong Shan Xi Road, Shanghai 200233 P. R. China **Tel. (86) 21 6440 0468, ext. 316**, FAX (86) 21 6440 0652

JAPAN: Microelectronics Group, Lucent Technologies Japan Ltd., 7-18, Higashi-Gotanda 2-chome, Shinagawa-ku, Tokyo 141, Japan

Tel. (81) 3 5421 1600, FAX (81) 3 5421 1700

EUROPE: Data Requests: MICROELECTRONICS GROUP DATALINE: **Tel. (44) 7000 582 368**, FAX (44) 1189 328 148

Technical Inquiries: GERMANY: **(49) 89 95086 0** (Munich), UNITED KINGDOM: **(44) 1344 865 900** (Ascot),

FRANCE: **(33) 1 40 83 68 00** (Paris), SWEDEN: **(46) 8 594 607 00** (Stockholm), FINLAND: **(358) 9 4354 2800** (Helsinki),

ITALY: **(39) 02 6608131** (Milan), SPAIN: **(34) 1 807 1441** (Madrid)

Lucent Technologies Inc. reserves the right to make changes to the product(s) or information contained herein without notice. No liability is assumed as a result of their use or application. No rights under any patent accompany the sale of any such product(s) or information. *Ambassador* is a trademark of Lucent Technologies Inc.





Exceptions and Clarifications for *Ambassador*[™] T8100A, T8102, and T8105 H.100/H.110 Interface and Time-Slot Interchangers

Device Exceptions

Users of the *Ambassador* T8100A, T8102, and T8105 devices should be aware of the following device operation exceptions and the associated solutions:

1. When a compatibility clock is programmed as a slave, and the board generates A or B clocks, the watchdog will indicate an error on the A or B clocks it generates. The error will be reported even though the generated clocks are good.

Workaround: Use the master board to accurately monitor the clocks.

2. When a compatibility clock is programmed as a slave, and the clock selector is set to A or B clocks with slide phase alignment, the slave board does not lock and the generated frame continues sliding.

Workaround: None.

Product Status: Device redesign required.

3. Models of the *Ambassador* T8100A, T8102, and T8105 devices exhibit intermittent corrupted time-slot data. H.100 stream 0 time slot 1 (for outgoing data) and H.100 stream 1 time slot 127 (for incoming data at 8.192 MHz, time slot 63 for 4.096 MHz, and time slot 31 for 2.048 MHz) are the most likely stream/time slots to be corrupted. However, intermittent time-slot corruption may occur in other stream/time slots.

The time-slot corruption problem occurs when a T810x device is used in slave-timing mode, as described in Section 2.5 of the Data Sheet. In a typical slave timing application, a T810x device is set to phase align to an incoming bitclock/frame reference pair (i.e., slave to CT_C8_A/FRAME_A, CT_C8_B/FRAME_B, C4/FR_COMP, etc.). Both SNAP and SLIDE alignment modes are affected. Devices that don't require phase alignment to these clocks (i.e., the primary bus master) should not exhibit stream data corruption.

Root Cause: The analog PLL has an error which introduces an unexpected 6 ns—7 ns of skew.

This skew causes the phase alignment circuit to fail intermittently, whether in the SNAP or SLIDE mode. An intermittent SLIDE produces an internal frame signal that does not align and phase lock with an incoming frame reference. An intermittent SNAP forces a reset of the internal counters and results in corrupted stream data.

Workaround: There is no workaround. The solution is a fix to the silicon. Samples are scheduled for release in August 1999.

4. Version 2 models of the *Ambassador* T8100A, T8102, and T8105 devices can exhibit intermittent corrupted time slot data in one specific configuration. The problem occurs when a master T810x device is given an 8 kHz signal as the timing reference and multiplies it up to 2.048 MHz or 4.096 MHz in the digital PLL (DPLL). The DPLL introduces sufficient jitter on the A or B master output clocks that slave devices falsely interpret as a loss of sync and either snap or slide align to this false sync indication. This, in turn, causes corruption of time slot data. Any master timing reference that does not make use of the DPLL does not exhibit the problem.

Workaround: Do not use an 8 kHz signal as the A or B master timing reference, since this requires use of the DPLL. Instead, supply a jitter-free timing reference at any of the other allowable frequencies (2.048, 4.096, 8.192 or 16.384 MHz).

Product Status: The solution is a fix to the silicon.

Device Clarifications

The three device clarifications listed in this space have been incorporated into DS00-028CTI.

For additional information, contact your Microelectronics Group Account Manager or the following:

INTERNET: <http://www.lucent.com/micro>

E-MAIL: docmaster@micro.lucent.com

N. AMERICA: Microelectronics Group, Lucent Technologies Inc., 555 Union Boulevard, Room 30L-15P-BA, Allentown, PA 18103
1-800-372-2447, FAX 610-712-4106 (In CANADA: **1-800-553-2448**, FAX 610-712-4106)

ASIA PACIFIC: Microelectronics Group, Lucent Technologies Singapore Pte. Ltd., 77 Science Park Drive, #03-18 Cintech III, Singapore 118256
Tel. (65) 778 8833, FAX (65) 777 7495

CHINA: Microelectronics Group, Lucent Technologies (China) Co., Ltd., A-F2, 23/F, Zao Fong Universe Building, 1800 Zhong Shan Xi Road, Shanghai 200233 P. R. China **Tel. (86) 21 6440 0468, ext. 316**, FAX (86) 21 6440 0652

JAPAN: Microelectronics Group, Lucent Technologies Japan Ltd., 7-18, Higashi-Gotanda 2-chome, Shinagawa-ku, Tokyo 141, Japan
Tel. (81) 3 5421 1600, FAX (81) 3 5421 1700

EUROPE: Data Requests: MICROELECTRONICS GROUP DATALINE: **Tel. (44) 7000 582 368**, FAX (44) 1189 328 148

Technical Inquiries: GERMANY: **(49) 89 95086 0** (Munich), UNITED KINGDOM: **(44) 1344 865 900** (Ascot),

FRANCE: **(33) 1 40 83 68 00** (Paris), SWEDEN: **(46) 8 594 607 00** (Stockholm), FINLAND: **(358) 9 4354 2800** (Helsinki),

ITALY: **(39) 02 6608131** (Milan), SPAIN: **(34) 1 807 1441** (Madrid)

Lucent Technologies Inc. reserves the right to make changes to the product(s) or information contained herein without notice. No liability is assumed as a result of their use or application. No rights under any patent accompany the sale of any such product(s) or information. *Ambassador* is a trademark of Lucent Technologies Inc.





Ambassador™ T8100A, T8102, and T8105 H.100/H.110 Interfaces and Time-Slot Interchangers

1 Product Overview

1.1 Features

- Complete solution for interfacing board-level circuitry to the H.100 telephony bus
- H.100 compliant interface; all mandatory signals
- Programmable connections to any of the 4096 time slots on the H.100 bus
- Up to 16 local serial inputs and 16 local serial outputs, programmable for 2.048 Mbits/s, 4.096 Mbits/s, and 8.192 Mbits/s operation per CHI specifications
- Programmable switching between local time slots, up to 1024 connections
- Subrate switching of nibbles, dibits, or bits
- Backward compatible to T8100 through software
- Programmable switching between local time slots and H.100 bus, up to 512 (T8102, T8105 only) connections
- Choice of frame integrity or minimum latency switching on a per-time-slot basis
 - Frame integrity to ensure proper switching of wideband data
 - Minimum latency switching to reduce delay in voice channels
- On-chip phase-locked loop (PLL) for H.100, *MVIP*^{*}, or SC-Bus clock operation in master or slave clock modes
- Serial TDM bus rate and format conversion between most standard buses
- Optional 8-bit parallel input and/or 8-bit parallel output for local TDM interfaces
- High-performance microprocessor interface
 - Provides access to device configuration registers and to time-slot data
 - Supports both *Motorola*[†] nonmultiplexed and *Intel*[‡] multiplexed/nonmultiplexed modes
- Two independently programmable groups of up to 12 framing signals each
- Devices available in 0.25 micron technology
- 3.3 V supply with 5 V tolerant inputs and TTL-compatible outputs
- Boundary-scan testing support
- 208-pin, plastic SQFP package
- 217-ball BGA package (industrial temperature range)

1.2 Description

These products in the *Ambassador* T8100 family provide a complete time-slot switch and an interface for the H.100/H.110 time-division multiplexed (TDM) buses. The T8100 family includes devices with hierarchical switching as well as a capacity of up to 512 local to H.100 connections. The hierarchical switching allows up to 1024 local connections without using H.100 bus bandwidth. The family also includes the T8102 device for a low-cost solution in nonhierarchical systems.

All three TSI chips are backward compatible with the bus standards *MVIP*-90 and *Dialogic's*[§] SC-Bus, as well as supporting the newer standards, H-*MVIP* and ECTF H.100. Other features include a built-in PLL for H.100, *MVIP*, or SC-Bus clock operation in master or slave clock modes and two independently programmable groups of up to 12 framing signals each. Packaged in both a 208-pin SQFP and a 217-ball BGA, the T8100 TSI devices provide an economic solution for the computer telephony market.

* *MVIP* is a registered trademark of GO-MVIP, Inc.

† *Motorola* is a registered trademark of Motorola, Inc.

‡ *Intel* is a registered trademark of Intel Corporation.

§ *Dialogic* is a registered trademark of Dialogic Corporation.

Table of Contents

Contents	Page	Contents	Page
1 Product Overview	1	2.5.2 Dividers and Rate Multipliers.....	45
1.1 Features.....	1	2.5.3 State Machines.....	45
1.2 Description	1	2.5.4 Frame Sync.....	45
1.3 Pin Information.....	6	2.5.5 Bit Sliding (Frame Locking)	45
1.4 <i>Ambassador</i> TSI Architecture	12	2.5.6 MTIE.....	46
1.5 Selecting Between T8105, T8102, T8100A, and T8100.....	12	2.5.6.1 MTIE Compliance	46
1.6 Enhanced Local Stream Addressing.....	12	2.5.6.2 Relationship of the Bit Slider to MTIE ...	46
1.7 Full H.100 Stream Address Support	12	2.5.6.3 Using the Bit Slider	46
1.8 Onboard PLLs and Clock Monitors	12	2.5.7 Clock Fallback.....	47
1.9 Phase Alignment of Referenced and Generated Frames.....	12	2.5.8 Clock Control Register Definitions.....	49
1.10 Interfaces	13	2.5.8.1 Basic Fallback Mode.....	54
1.10.1 Microprocessors.....	13	2.5.8.2 CKMD, CKND, CKRD: Clocks, Main, NETREF, Resource Dividers 0x07, 0x08, 0x09	55
1.10.2 Framing Groups	13	2.5.9 LREF Pairing.....	57
1.10.3 General-Purpose Register and I/O.....	13	2.5.9.1 LREF Port Configuration.....	57
1.11 Applications.....	13	2.5.9.2 Operation	58
1.12 Application Overview	13	2.5.9.3 Example of LREF Pairing on a T8100A	58
2 Architecture and Functional Description.....	13	2.5.9.4 Advantages of LREF Pairing	58
2.1 Register/Memory Maps.....	15	2.6 Interface Section	58
2.1.1 Main Registers	15	2.6.1 Microprocessor Interface.....	58
2.1.2 Master Control and Status Register	15	2.6.2 General-Purpose Register.....	58
2.1.3 Address Mode Register.....	16	2.6.3 Framing Groups	59
2.1.4 Control Register Memory Space	17	2.6.3.1 Frame Group Timing.....	60
2.2 Local Bus Section	23	2.7 Error Registers	62
2.2.1 Constant Frame Delay and Minimum Delay Connections	24	2.8 The JTAG Test Access Port.....	64
2.2.2 Serial and Parallel	24	2.8.1 Overview of the JTAG Architecture	64
2.2.3 Data Rates and Time-Slot Allocation	25	2.8.2 Overview of the JTAG Instructions.....	64
2.2.4 LBS: Local Stream Control, 0x0C	28	2.8.3 Elements of JTAG Logic.....	65
2.2.5 State Counter Operation	29	2.9 Testing and Diagnostics.....	66
2.2.6 Software to Reset the Local Connection Memory	29	2.9.1 Testing Operations	66
2.3 H-Bus Section	30	2.9.2 Diagnostics	66
2.3.1 Memory Architecture	30	3 Using the TSI Devices	69
2.3.2 CAM Operation and Commands	32	3.1 Resets	69
2.3.3 H-Bus Access.....	36	3.1.1 Hardware Reset	69
2.3.4 L-Bus Access	37	3.1.2 Software Reset.....	69
2.3.5 H-Bus Rate Selection and Connection Address Format.....	37	3.1.3 Power-On Reset.....	69
2.4 Substrate Switching for the <i>Ambassador</i> Family.....	39	3.2 Device Settings	70
2.4.1 Description, Operation, and Application.....	39	3.2.1 Architecture	70
2.4.2 Definitions	39	3.3 Basic Connections	71
2.4.3 Substrate Switching on H.100/H.110	39	3.3.1 LPUE Control Pins	71
2.4.4 Using the Existing Architecture	40	3.3.2 H.100/H.110 Data Pin Series Termination	71
2.4.5 Limitations	42	3.3.3 H.110 Hot Swap	71
2.4.6 Minimum vs. Constant Delay.....	43	3.3.4 Physical Connections for H.100	72
2.4.7 Example of a Practical Application.....	43	3.3.5 Physical Connections for H.110	72
2.5 Clocking Section	43	3.3.6 PC Board BGA Considerations	72
2.5.1 Clock and NETREF Selection	45	3.4 Using the LAR, AMR, and IDR for Connections	73
		3.4.1 Setting Up Local Connections (T8100A, T8105 Only).....	73

Table of Contents (continued)

Contents	Page	Figures	Page
3.4.2 Setting Up H-Bus Connections.....	75	Figure 1. 208 SQFP—Top View	6
3.4.3 Programming Examples.....	78	Figure 2. 217 PBGA—Top View	7
3.4.4 Miscellaneous Commands	81	Figure 3. Block Diagram of the TSI Devices.....	14
4 Electrical Characteristics	82	Figure 4. Local Bus Section Function	23
4.1 Absolute Maximum Ratings	82	Figure 5. Local Bus Memory Connection Modes.....	24
4.2 Handling Precautions	82	Figure 6. Local Streams, Memory Structure	25
4.3 Crystal Information.....	83	Figure 7. Local Memory (T8100A, T8105 Only), Fill Patterns	26
4.4 Reset Pulse.....	83	Figure 8. Simplified Local Memory State Timing, 65.536 MHz Clock	29
4.5 Thermal Considerations.....	83	Figure 9. CAM Architecture	31
4.5.1 Thermal Considerations for the 208 SQFP	83	Figure 10. Simplified H-Bus State Timing, 65.536 MHz Clock	33
4.5.2 Thermal Considerations for the 217 PBGA	83	Figure 11. Illustration of CAM Cycles	35
4.6 dc Electrical Characteristics, H-Bus (ECTF H.100 Spec., Rev. 1.0).....	84	Figure 12. Substrate Switching Example	39
4.6.1 Electrical Drive Specifications—CT_C8 and /CT_FRAME.....	84	Figure 13. Modifications for Substrate Switching	41
4.7 dc Electrical Characteristics, All Other Pins.....	84	Figure 14. Unpacking Example Using Local Loopback.....	42
4.8 H-Bus Timing (Extract from H.100 Spec., Rev. 1.0).....	85	Figure 15. Constant Delay/Minimum Delay Example	43
4.8.1 Clock Alignment	85	Figure 16. Clocking Section.....	44
4.8.2 Frame Diagram	85	Figure 17. A, B, and C Clock Fallback State Diagram	47
4.8.3 Detailed Timing Diagram.....	86	Figure 18. Programming Sequence.....	48
4.8.4 ac Electrical Characteristics, Timing, H-Bus (H.100 Spec., Rev. 1.0).....	87	Figure 19. Frame Group Output Options.....	61
4.8.5 Detailed Clock Skew Diagram.....	88	Figure 20. External Connection to PLLs.....	71
4.8.6 ac Electrical Characteristics, Skew Timing, H-Bus (H.100 Spec., Rev. 1.0).....	88	Figure 21. Physical Connections for H.110	72
4.8.7 Reset and Power On.....	89	Figure 22. Local-to-Local Connection Programming (T8100A, T8105 Only)	74
4.9 ac Electrical Characteristics, Local Streams, and Frames	89	Figure 23. CAM Programming, H-Bus-to-Local Connection	76
4.10 ac Electrical Characteristics, Microprocessor Timing	91	Figure 24. Clock Alignment	85
4.10.1 Microprocessor Access <i>Intel</i> Multiplexed Write and Read Cycles.....	91	Figure 25. Frame Diagram	85
4.10.2 Microprocessor Access <i>Motorola</i> Write and Read Cycles.....	92	Figure 26. Detailed Timing Diagram.....	86
4.10.3 Microprocessor Access <i>Intel</i> Demultiplexed Write and Read Cycles.....	93	Figure 27. Detailed Clock Skew Diagram.....	88
5 Outline Diagrams.....	94	Figure 28. ac Electrical Characteristics, Local Streams, and Frames	90
5.1 208-Pin Square Quad Flat Package (SQFP)	94	Figure 29. Microprocessor Access <i>Intel</i> Multiplexed Write Cycle.....	91
5.2 217-Ball Plastic Ball Grid Array (PBGA)	95	Figure 30. Microprocessor Access <i>Intel</i> Multiplexed Read Cycle.....	91
6 Ordering Information.....	96	Figure 31. Microprocessor Access <i>Motorola</i> Write Cycle	92
Appendix A. Application of Clock Modes.....	97	Figure 32. Microprocessor Access <i>Motorola</i> Read Cycle.....	92
Appendix B. Minimum Delay and Constant Delay Connections.....	103	Figure 33. Microprocessor Access <i>Intel</i> Demultiplexed Write Cycle	93
B.1 Connection Definitions.....	103	Figure 34. Microprocessor Access <i>Intel</i> Demultiplexed Read Cycle	93
B.2 Delay Type Definitions.....	104		
B.2.1 Exceptions to Minimum Delay.....	105		
B.2.2 Lower Stream Rates	105		
B.2.3 Mixed Minimum/Constant Delay	106		
Appendix C. CAM Readback and Pattern Fill Mode	107		

Table of Contents (continued)

Figures	Page	Tables	Page
Figure 35. E1, CT Bus Master, Compatibility Clock Master, Clock Source = 2.048 MHz from Trunk	98	Table 16. CKS: Clocks, Secondary (Fallback) Selection, 0x04	18
Figure 36. T1, CT Bus Master, Compatibility Clock Master, Clock Source = 1.544 MHz from Trunk	99	Table 17. CK32: Clocks, Locals 3 and 2, 0x05	18
Figure 37. E1, Slave to CT Bus, Clock Source Is Either a 16 MHz or a 4 MHz or a 2 MHz and Frame, NETREF Source = 2.048 MHz from Trunk	100	Table 18. CK10: Clocks, Locals 1 and 0, 0x06	18
Figure 38. T1, Slave to CT Bus, Clock Source Is Either a 16 MHz or a 4 MHz or a 2 MHz and Frame, NETREF Source = 1.544 MHz from Trunk	101	Table 19. CKMD: Clocks, Main Divider; CKND: Clocks, NETREF Divider; CKRD: Clocks, Resource Divider, 0x07, 0x08, 0x09	19
Figure 39. Constant Delay Connections, CON[1:0] = 0X	104	Table 20. LBS: Local Stream Control, 0x0C	19
Figure 40. Minimum Delay Connections, CON[1:0] = 0X	105	Table 21. CON: Connection Delay Type, 0x0E	19
Figure 41. Mixed Minimum/Constant Delay Connections, CON[1:0] = 10]	106	Table 22. HSL: H-Bus Stream Control, Low Byte, 0x10	19
Figure 42. Extended Linear (Mixed Minimum/Constant) Delay, CON[1:0] = 11	107	Table 23. HSH: H-Bus Stream Control, High Byte, 0x11	19
Tables	Page	Table 24. GPD, General-Purpose Direction Control Register, 0x17	19
Table 1. Pin Descriptions: Clocking and Framing Pins	8	Table 25. GPR: General-Purpose I/O Register, 0x18	20
Table 2. Pin Descriptions: Local Streams Pins	9	Table 26. FRLA: Frame Group A, Start Address Low, 0x20	20
Table 3. Pin Descriptions: H-Bus Pins	9	Table 27. FRHA: Frame Group A, High Address and Control, 0x21	20
Table 4. Pin Descriptions: Microprocessor Interface Pins	10	Table 28. FRLB: Frame Group B, Start Address Low, 0x22	20
Table 5. Pin Descriptions: JTAG Pins	10	Table 29. FRHB: Frame Group B, High Address and Control, 0x23	20
Table 6. Pin Descriptions: Power Pins	11	Table 30. FRPL: Frame Group B, Programmed Output, Low, 0x24	21
Table 7. Pin Descriptions: Other Pins	11	Table 31. FRPH: Frame Group B, Programmed Output, High, 0x25	21
Table 8. Addresses of Programming Registers	15	Table 32. CLKERR1: Clock Error Register, Error Indicator, 0x28	21
Table 9. Master Control and Status Register	15	Table 33. CLKERR2: Clock Error Register, Current Status, 0x29	21
Table 10. Address Mode Register	16	Table 34. SYSERR: System Error Register, 0x2A	21
Table 11. Control Register Memory Space	17	Table 35. CKW: Clock Error/Watchdog Masking Register, 0x2B	21
Table 12. CKM: Clocks, Main Clock Selection, 0x00	18	Table 36. CLKERR3: Clock Error Register, Current Status, 0x2C	21
Table 13. CKN: Clocks, NETREF Selections, 0x01	18	Table 37. DIAG1: Diagnostics Register 1, 0x30	22
Table 14. CKP: Clocks, Programmable Outputs, 0x02	18	Table 38. DIAG2: Diagnostics Register 2, 0x31	22
Table 15. CKR: Clocks, Resource Selection, 0x03	18	Table 39. DIAG3: Diagnostics Register 3, 0x32	22
		Table 40. DEV_ID: Device Identification Register, 0xFE	22
		Table 41. GMODE: Global Mode Register, 0xFF	22
		Table 42. LBS: Local Stream Control, 0x0C	28

Table of Contents (continued)

Tables	Page	Tables	Page
Table 43. HSL: H-Bus Stream Control, Low Byte, 0x10.....	37	Table 63. DIAG1: Diagnostics Register 1, 0x30.....	67
Table 44. HSL: H-Bus Stream Control, High Byte, 0x11.....	38	Table 64. DIAG2: Diagnostics Register 2, 0x31.....	68
Table 45. Permitted Tag Extensions	40	Table 65. DIAG3: Diagnostics Register 3, 0x32.....	68
Table 46. CKM: Clocks, Main Clock Selection, 0x00	49	Table 66. Device Identification Register, 0xFE	70
Table 47. CKN: Clocks, NETREF Selections, 0x01	50	Table 67. GMODE: Global Mode Register, 0xFF	70
Table 48. CKP: Clocks, Programmable Outputs, 0x02	51	Table 68. LPUE Control Pins	71
Table 49. CKR: Clocks, Resource Selection, 0x03	52	Table 69. Time-Slot Bit Decoding	73
Table 50. CKS: Clocks, Secondary (Fallback) Selection, 0x04	53	Table 70. IDR: Indirect Data Register, Local Connections Only	74
Table 51. CK32 and CK10: Clocks, Locals 3, 2, 1, and 0, 0x05 and 0x06	55	Table 71. IDR: Indirect Data Register, H-Bus Connections Only	75
Table 52. CON Register 0x0E	56	Table 72. Crystal Specifications	83
Table 53. LREF Pairs.....	57	Table 73. Use of an Oscillator as an Alternative to Using a Crystal	83
Table 54. CKM (0x00) CKSEL Values to Select LREF Pairs	57	Table 74. Electrical Drive Specifications—CT_C8 and /CT_FRAME	84
Table 55. FRHA, Frame Group A High Address and Control, 0x21	59	Table 75. dc Electrical Characteristics, All Other Pins	84
Table 56. FRHB, Frame Group B High Address and Control, 0x23	59	Table 76. ac Electrical Characteristics, Timing, H-Bus (H.100 Spec., Rev. 1.0)	87
Table 57. FRPH: Frame Group B, Programmed Output, High, 0x25	61	Table 77. ac Electrical Characteristics, Skew Timing, H-Bus (H.100 Spec., Rev. 1.0)	88
Table 58. CLKERR1 and CLKERR2: Error Indicator and Current Status, 0x28 and 0x29	62	Table 78. Reset and Power On	89
Table 59. CLKERR3: Error Indicator and Current Status, 0x2C	63	Table 79. ac Electrical Characteristics, Local Streams, and Frames	89
Table 60. SYSERR: System Error Register, 0x2A	63	Table 80. L_SC[3:0] and Frame Group Rise and Fall Time	89
Table 61. JTAG Instruction Set	64	Table 81. Microprocessor Access Timing	93
Table 62. JTAG Scan Register	65	Table 82. Clock Register Programming Profile for the Four Previous Examples	102
		Table 83. Table of Special Cases (Exceptions)	105

1 Product Overview (continued)

1.3 Pin Information

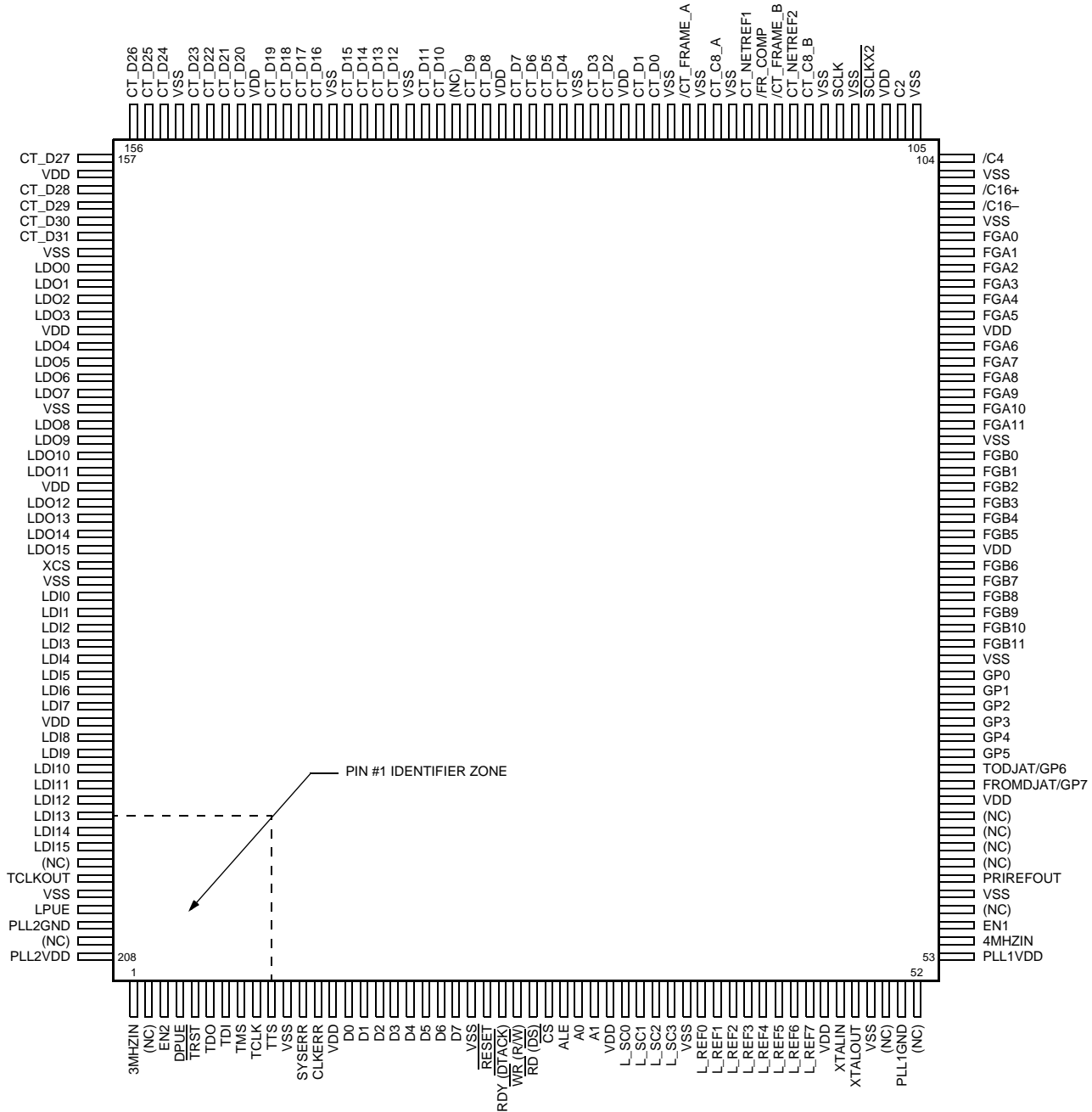

5-6118cF

Figure 1. 208 SQFP—Top View

1 Product Overview (continued)

1.3 Pin Information (continued)

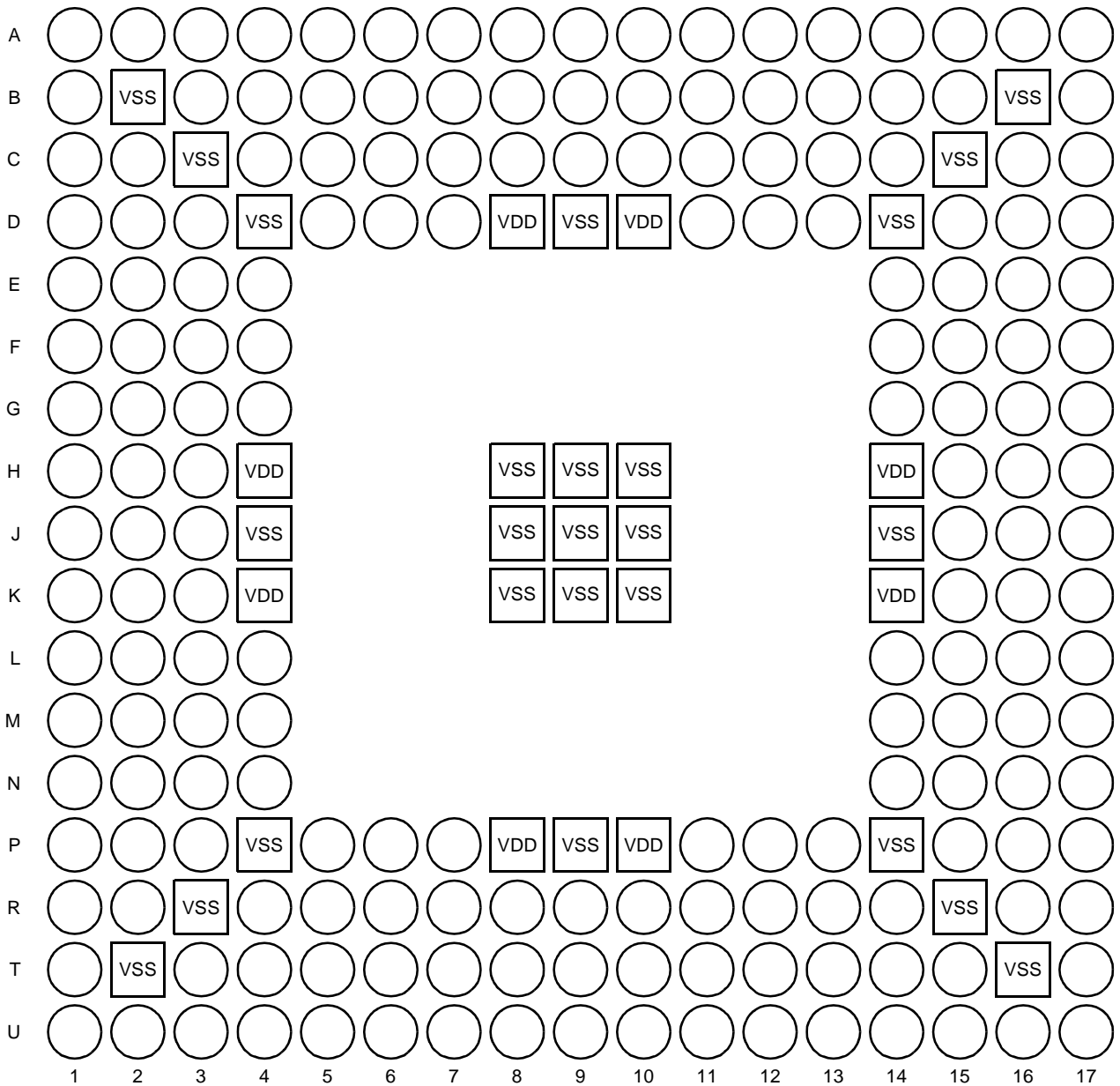

5-6626a(F)

Figure 2. 217 PBGA—Top View

1 Product Overview (continued)

1.3 Pin Information (continued)

Table 1. Pin Descriptions: Clocking and Framing Pins

Symbol	Pin	Ball	Type	Name/Description
L_REF[7:0]	45—38	P3, N4, R1, P2, N3, M4, P1, N2	I	Local Frame Reference Inputs. 50 k Ω internal pull-up.
/C16+	102	R14	I/O	H-MVIP 16.384 MHz Clock Signals. Differential 24 mA drive, Schmitt in, 50 k Ω internal pull-up.
/C16-	101	P13		
/C4	104	U16	I/O	MVIP 4.096 MHz Clock. 8 mA drive, Schmitt in, 50 k Ω internal pull-up.
C2	106	T17	I/O	MVIP 2.048 MHz Clock. 8 mA drive, Schmitt in, 50 k Ω internal pull-up.
SCLK	110	R17	I/O	SC-Bus 2/4/8 MHz Clock. 24 mA drive, Schmitt in, 50 k Ω internal pull-up.
SCLKX2	108	P15	I/O	SC-Bus Inverted 4/8 MHz Clock (Active-Low). 24 mA drive, Schmitt in, 50 k Ω internal pull-up.
L_SC[3:0]	36—33	M3, N1, M2, M1	O	Local Selected Clocks. 1.024 MHz, 2.048 MHz, 4.096 MHz, 8.192 MHz, 16.384 MHz, frame (8 kHz), or secondary (NETREF). 8 mA drive, 3-state.
FGA[5:0]	94—99	R12, T13, U14, P12, R13, T14	O	Frame Group A. 8 mA drive, 3-state.
FGA[11:6]	87—92	T11, P11, R11, U12, T12, U13		
FGB[5:0]	80—85	U9, R9, U10, T10, R10, U11	O	Frame Group B. 8 mA drive, 3-state.
FGB[11:6]	73—78	U6, T7, R8, U7, T8, U8		
PRIREFOUT	58	P5	O	Output from Primary Clock Selector/Divider. 8 mA drive.
PLL1VDD	53	U1	—	PLL #1 VCO Power. This pin must be connected to power, even if PLL #1 is not used.
PLL1GND	51	No ball for this signal, internally connected.	—	PLL #1 VCO Ground. This pin must be connected to ground, even if PLL #1 is not used.
EN1	55	T3	I	PLL #1 Enable. Requires cap to Vss to form power-on reset, or may be driven with RESET line. 50 k Ω internal pull-up.
4MHZIN	54	U2	I	PLL #1 Rate Multiplier. Can be 2.048 MHz or 4.096 MHz. 50 k Ω internal pull-up.
PLL2VDD	208	A2	—	PLL #2 VCO Power. This pin must be connected to power, even if PLL #2 is not used.
PLL2GND	206	No ball for this signal, internally connected.	—	PLL #2 VCO Ground. This pin must be connected to ground, even if PLL #2 is not used.
EN2	3	C2	I	PLL #2 Enable. Requires cap to Vss to form power-on reset, or may be driven with RESET line. 50 k Ω internal pull-up.
3MHZIN	1	A1	I	PLL #2 Rate Multiplier. Input, 50 k Ω internal pull-up.
XTALIN	47	R2	I	16.384 MHz Crystal Connection or External Clock Input.
XTALOUT	48	T1	O	16.384 MHz Crystal, Feedback Connection.
TCLKOUT	203	C4	O	Selected output to drive framers. 8 mA drive, 3-state.
CLKERR	13	E1	O	Clock Error. Logical OR of CLKERR register flags (only). 8 mA drive, 3-state.
SYSERR	12	F3	O	System Error. Logical OR of all CLKERR and SYSERR register flags. 8 mA drive, 3-state.

1 Product Overview (continued)

1.3 Pin Information (continued)

Table 2. Pin Descriptions: Local Streams Pins

Symbol	Pin	Ball	Type	Name/Description
LDI[15:8] LDI[7:0]	201—194 192—185	A3, B4, C5, D6, A4, B5, C6, A5 B6, A6, C7, D7, B7, A7, C8, B8	I	Local Data Input Streams. 50 k Ω internal pull-up.
LDO[15:12] LDO[11:8] LDO[7:4] LDO[3:0]	182—179 177—174 172—169 167—164	C9, A9, B9, A10 B10, A11, C10, B11 D11, C11, B12, A13 B13, A14, C13, D12	O	Local Data Output Streams. 8 mA drive, 3-state.

Table 3. Pin Descriptions: H-Bus Pins

Symbol	Pin	Ball	Type	Name/Description
CT_D[31:28] CT_D[27:24] CT_D[23:20] CT_D[19:16] CT_D[15:12] CT_D[11:10] CT_D[9:8] CT_D[7:4] CT_D[3:2] CT_D[1:0]	162—159 157—154 152—149 147—144 142—139 137—136 134—133 131—128 126—125 123—122	A15, D13, C14, B15 A17, C16, D15, E14 C17, D16, E15, F14 D17, E16, F15, E17 F16, F17, G15, G14 G16, G17 H15, H16 H17, J15, J17, J16 K17, K16 L17, K15	I/O	H-Bus, Data Lines. Variable rate 2 Mbits/s, 4 Mbits/s, 8 Mbits/s. 5 V tolerant, PCI compliant, 50 k Ω internal pull-up.
/CT_FRAME_A	120	L14	I/O	H-Bus, 8 kHz, Frame. 5 V tolerant, PCI compliant, 24 mA drive, Schmitt in. No pull-up.
/CT_FRAME_B	114	P17	I/O	H-Bus, Alternate 8 kHz Frame. 5 V tolerant, PCI compliant, 24 mA drive. Schmitt in. No pull-up.
/FR_COMP	115	M15	I/O	H-Bus, Compatibility Frame Signal. 24 mA drive, Schmitt in, 50 k Ω internal pull-up.
CT_NETREF1	116	N17	I/O	H-Bus, Network Reference 1. 8 kHz, 2.048 MHz, or 1.544 MHz. PCI driver. Not internally pulled up.
CT_NETREF2	113	N15	I/O	H-Bus, Network Reference 2. 8 kHz, 2.048 MHz, or 1.544 MHz. PCI driver. Not internally pulled up.
CT_C8_A	118	M16	I/O	H-Bus, Main Clock. 5 V tolerant, PCI compliant, 24 mA drive, Schmitt in. No pull-up.
CT_C8_B	112	M14	I/O	H-Bus, Alternate Main Clock. 5 V tolerant, PCI compliant, 24 mA drive, Schmitt in. No pull-up.
LPUE	205	B3	I	Local Pull-Up Enable. A low disables all pull-ups other than the CT_Dxx lines and the legacy clocks C2, /C4, /C16+, /C16-, SCLK, SCLKX2, and /FR_COMP. 50 k Ω internal pull-up. See Section 3.3.5 Physical Connections for H.110.
DPUE	4	D3	I	Data Pull-Up Enable. High enables pull-ups on CT_Dxx only for H.100, low disables for H.110. 50 k Ω internal pull-up.

1 Product Overview (continued)

1.3 Pin Information (continued)

Table 4. Pin Descriptions: Microprocessor Interface Pins

Symbol	Pin	Ball	Type	Name/Description
$\overline{\text{RESET}}$	24	J1	I	Master Reset (Active-Low). See Section 3.1 Resets. 50 k Ω internal pull-up.
A[1:0]	31—30	L4, L2	I	Microprocessor Interface, Address Lines. Internal 20 k Ω pull-down.
D[7:0]	22—15	H1, H2, G1, H3, G2, F1, G4, G3	I/O	Microprocessor Interface, Data Lines. 8 mA drive, 50 k Ω internal pull-up.
ALE	29	L1	I	Address Latch Enable. Internal 20 k Ω pull-down.
$\overline{\text{CS}}$	28	K3	I	Chip Select (Active-Low). 50 k Ω internal pull-up.
$\overline{\text{RD}}$ ($\overline{\text{DS}}$)	27	K2	I	Read Strobe (<i>Intel</i> Mode [Active-Low]), Data Strobe (<i>Motorola</i> [Active-Low]). 50 k Ω internal pull-up.
$\overline{\text{WR}}$ (R $\overline{\text{W}}$)	26	K1	I	Write Strobe (<i>Intel</i> [Active-Low]), Read/Write Select (<i>Motorola</i> [Active-Low]). 50 k Ω internal pull-up.
RDY ($\overline{\text{DTACK}}$)	25	J3	O	Data Ready (<i>Intel</i>), Data Transfer (<i>Motorola</i> [Active-Low]). 8 mA, open drain (user should add pull-up to this line).

Table 5. Pin Descriptions: JTAG Pins

Symbol	Pin	Ball	Type	Name/Description
TCLK	9	E3	I	JTAG Clock Input.
TMS	8	F4	I	JTAG Mode Select. 50 k Ω internal pull-up.
TDI	7	D2	I	JTAG Data Input. 50 k Ω internal pull-up.
TDO	6	C1	O	JTAG Data Output. 8 mA drive, 3-state.
$\overline{\text{TRST}}$	5	E4	I	JTAG Reset (Active-Low). 50 k Ω internal pull-up.

1 Product Overview (continued)

1.3 Pin Information (continued)

Table 6. Pin Descriptions: Power Pins

Symbol	Pin	Ball	Type	Name/Description
V _{SS}	11, 23, 37, 49, 57, 72, 86, 100, 103, 105, 109, 111, 117, 119, 121, 127, 138, 143, 153, 163, 173, 184, 204	B2, B16, C3, C15, D4, D9, D14, H8, H9, H10, J4, J8, J9, J10, J14, K8, K9, K10, L15, N14, P4, P9, P14, P16, R3, R15, T2, T15, T16, U15, U17	—	Chip Ground.
V _{DD}	14, 32, 46, 63, 79, 93, 107, 124, 132, 148, 158, 168, 178, 193	A16, D8, D10, F2, H4, H14, K4, K14, L16, P8, P10, T9	—	3.3 V Supply Voltage. Decouple every V _{DD} pin with a 0.1 μF ceramic capacitor to V _{SS} . 1000 pF or 0.01 μF capacitors may be used in addition to the 0.1 μF capacitor to provide additional decoupling. Place the capacitor as close to the V _{DD} pin as possible.

Table 7. Pin Descriptions: Other Pins

Symbol	Pin	Ball	Type	Name/Description
GP[5:0]	66—71	T5, R6, U5, T6, R7, P7	I/O	General-Purpose Bidirectional Register. 8 mA drive, Schmitt in, 50 kΩ internal pull-up.
TODJAT/GP6	65	U4	I/O	Output from Selector to Drive DJAT (for NETREF) or GP Register Bit 6. 8 mA drive, Schmitt in, 50 kΩ internal pull-up.
FROMDJAT/GP7	64	R5	I/O	Smoothed Input to NETREF Divider and Drivers or GP Register Bit 7. 8 mA drive, input, Schmitt in, 50 kΩ internal pull-up.
XCS	183	A8	O	Serial Output from Connection Memory. 8 mA drive, 3-state.
TTS	10	D1	I	Test Type Select. 0 = JTAG, 1 = forced output test, internal pull-down.
(NC)	2, 50, 52, 56, 59, 60, 61, 62, 135, 202, 207	A12, B1, B14, B17, C12, D5, E2, J2, L3, M17, N16, P6, R4, R16, T4, U3	—	Reserved, No Connection.

1 Product Overview (continued)

1.4 Ambassador TSI Architecture

The *Ambassador* programmable TSIs have been designed to meet today's switching requirements. The T8100A and T8105 TSIs have a hierarchical switching capability. They can switch between the local input bus and the local output bus. They also switch between the H.100/H.110 bus and local bus. The T8102 TSI switches between the H.100/H.110 bus and the local bus.

All three TSIs have circuitry for subrate switching and can interface to other computer telephony standards such as *MVIP*, SC-Bus, and MC-1*.

1.5 Selecting Between T8105, T8102, T8100A, and T8100

Features	T8100	T8100A	T8102	T8105
Subrate switching	—	√	√	√
Local-to-local connections	1,024	1,024	—	1,024
Local-to-H.100 connections	256	256	512	512
CT_NETREFs	1	2	2	2

1.6 Enhanced Local Stream Addressing

Local stream addressing has 1024 locations. Separate connection and data memories (T8100A, T8105 only) maintain all necessary information for local stream interconnections. The streams may operate at maximum rate on eight physical inputs and eight physical outputs. Choices for slower input or output rates allow enabling of additional physical inputs or outputs for a maximum of 16 pins each. Data rates are 2.048 Mbits/s, 4.096 Mbits/s, or 8.192 Mbits/s.

In addition to the enhanced serial streaming, the local memories may be used for 8-line-serial-in/1-byte-parallel-out, 1-byte-parallel-in/8-line-serial-out, or 1-byte-parallel-in/1-byte-parallel-out options. All three data rates are supported in the parallel modes. The addresses for the local memories (T8100A, T8105 only) have been simplified so that stream and time-slot designations are automatically translated to the appropriate memory address, regardless of rate or serial/parallel modes.

* MC-1 is a multichassis communication standard based on *MVIP*. The devices support this standard.

1.7 Full H.100 Stream Address Support

The devices provide access to the full 4096 H.100 bus slots (32 streams x 128 slots) or any standard subset (*H-MVIP* has a maximum 24 streams x 128 time slots, for example). The number of stored time-slot addresses is limited to 512 (T8102, T8105 only) at any one time, but these may be updated on the fly. In addition, accesses to and from the H.100 bus can be directed through the 1024 local stream/time slots, giving a total space of 5120 time slots. Data rates are programmable on each of the 32 physical streams, selected in groups of four. The rates are 2.048 Mbits/s, 4.096 Mbits/s, or 8.192 Mbits/s.

1.8 Onboard PLLs and Clock Monitors

The devices use rate multipliers and state machines to generate onboard frequencies for supporting the H.100, *H-MVIP*, *MVIP*, MC-1, and SC-Buses. Pins are provided for coupling the internal clock circuitry with commonly available clock adapters and jitter attenuators. If external resources are not available, an internal digital phase-locked loop (DPLL) can be used to generate all the bus frequencies and remain synchronized to an 8 kHz reference. One of several clock input reference sources may be selected, and separate input-active detection logic can identify the loss of the individual input references. The entire clocking structure operates from a 16.384 MHz crystal or external input.

1.9 Phase Alignment of Referenced and Generated Frames

If this resource is selected, special control logic will create bit-sliding in the data streams when the reference frame and generated frame are out of phase. The bit-sliding refers to removing a fraction of a bit time per frame until the frames are in phase.

1 Product Overview (continued)

1.10 Interfaces

1.10.1 Microprocessors

The devices provide the user a choice of either *Motorola* or *Intel* interfacing through an 8-bit data bus, a 2-bit address bus, and multifunction control pins. All access to the devices' memory blocks and registers use indirect addressing.

1.10.2 Framing Groups

Two groups of programmable framing signals are available. Each group is composed of 12 sequenced lines operating in one of four modes. The devices support 1-bit, 2-bit, 1-byte, and 2-byte pulse widths. Starting position of the pulse sequences are also programmable.

1.10.3 General-Purpose Register and I/O

A general-purpose, 8-bit, input/output port is provided as either byte-wide I/O or bit addressed I/O.

1.11 Applications

- Computer-telephony systems
- Enhanced service platforms
- WAN access devices
- PBXs
- Wireless base stations

1.12 Application Overview

The integration of computers and telecommunications has enabled a wide range of new communications applications and has fueled an enormous growth in communications markets. A key element in the development of computer-based communications equipment has been the addition of an auxiliary telecom bus to existing computer systems. Most manufacturers of high-capacity, computer-based telecommunications equipment have incorporated some such telecom bus in their systems. Typically, these buses and bus interfaces are designed to transport and switch $N \times 64$ kbits/s low-latency telecom traffic between boards within the computer, independent of the computer's I/O and memory buses. At least a half dozen of these PC-based telecom buses emerged in the early 1990s for use within equipment based on ISA/EISA and MCA computers.

With the advent of the H.100 bus specification by the Enterprise Computer Telephony Forum, the computer-telephony industry has agreed on a single telecom bus for use with PCI and compact PCI computers. H.100 facilitates interoperation of components, thus providing maximum flexibility to equipment manufacturers, value-added resellers, system integrators, and others building computer-based telecommunications applications.

2 Architecture and Functional Description

The devices are H.100-compliant and provide a complete interface between the H.100 bus and a wide variety of telephony interface components, processors, and other circuits. The bus interface provides all signals needed for the H.100 bus, the H-*MVIP* and *MVIP-90* buses, or the SC-Bus. Local interfaces include 16 serial inputs and 16 serial outputs based on the Lucent Technologies Microelectronics Group concentration highway interface (CHI). The T8100A and the T8105 include two built-in time-slot interchangers. The first provides a local switching domain with up to 1024 programmable connections between time slots on the local CHI inputs and outputs. The second provides programmable connections between any time slot on the H.100 bus and any time slot in the local switching domain. The T8105 has 512 programmable connections while the T8100A has 256. The T8102 has only 1 TSI for switching up to 512 programmable connections on the H.100 bus and any time slot in the local switching domain. All *Ambassador* devices are configured via a microprocessor interface. This interface can also read and write time slot and device data. Onboard clock circuitry, including a DPLL, supports all H.100 clock modes including *MVIP* and SC-Bus compatibility clocks. The local CHI interfaces support PCM rates of 2.048 Mbits/s, 4.096 Mbits/s, and 8.192 Mbits/s. Each device has internal circuitry to support either minimum latency or multi-time-slot frame integrity. Frame integrity is a requisite feature for applications that switch wide-band data (ISDN H-channels). Minimum latency is advantageous in voice applications.

All three TSIs have the following four major sections:

- Local bus—refers to the local streams.
- H-bus—refers to the H.100/H.110/H-*MVIP* and legacy streams.
- Interface—refers to the microprocessor interface, frame groups, and general-purpose I/O (GPIO).
- Timing—the rate multipliers, DPLL, and clocking functions.

2 Architecture and Functional Description (continued)

Figure 3 shows a block diagram of the TSI devices. The devices operate on a 3.3 V supply for both the core and I/Os, though the I/Os are TTL compatible and 5 V tolerant.

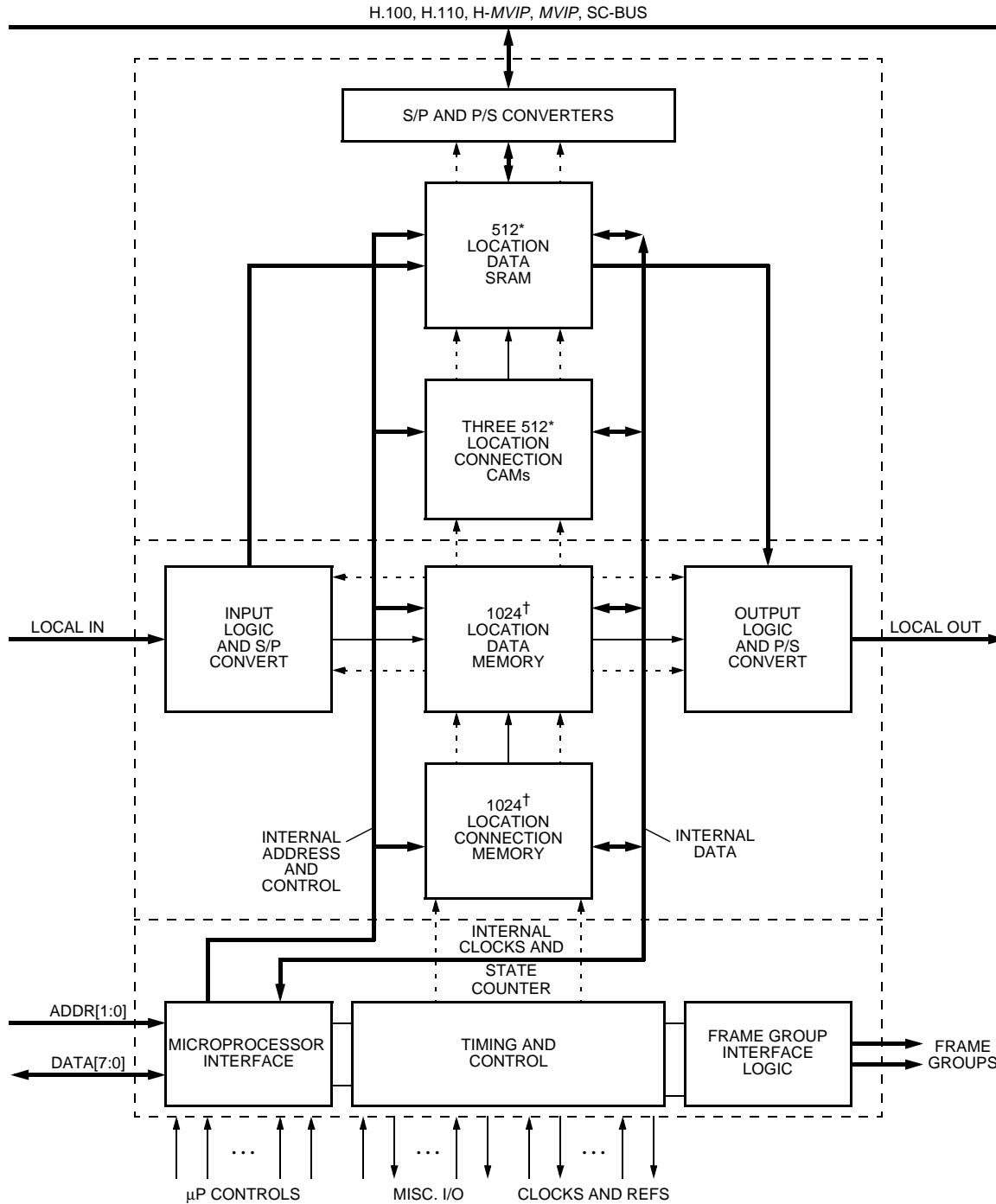

* For T8100 and T8100A, there are only 256 locations.
 † T8102 does not have local data memory.

5-6101.a (F)

Figure 3. Block Diagram of the TSI Devices

2 Architecture and Functional Description (continued)

2.1 Register/Memory Maps

In this section, a general overview of the registers and the indirect mapping to different memory spaces is described. More detailed descriptions for using the registers in software can be found in Section 3.4 Using the LAR, AMR, and IDR for Connections.

(Throughout this document, all registers are defined with the MSB on the left and the LSB on the right.)

2.1.1 Main Registers

The address bits are used to map a large memory space.

All registers default to 0 at powerup.

Table 8. Addresses of Programming Registers

A1	A0	Symbol	Name/Description
0	0	MCR	Master Control and Status Register (read/write)
0	1	LAR	Lower Address Register—Lower Indirect Address (time slot) (write only)
1	0	AMR	Address Mode Register—Upper Address (stream) and Address Type (write only)
1	1	IDR	Indirect Data Register (read/write)

2.1.2 Master Control and Status Register

Table 9. Master Control and Status Register

Symbol	Bit	Name/Description
MR	7	Master (Software) Reset. A high reinitializes the registers.
CER	6	Clock Error Reset. A high resets the error bits of the CLKERR registers.
SER	5	System Error Reset. A high resets the error bits of the SYSERR register. (Note that MR, CER, and SER are automatically cleared after the requested reset is complete.)
AP	4	Active Page. This bit identifies which of the double-buffered data memories are active. A zero indicates buffer 0; a one indicates buffer 1. The AP identifies which data buffer is being accessed during a write operation (i.e., input from local streams or input from H-bus).
HBE	3	H-Bus Enable. On powerup or software reset, all H-bus pins (including clocks) are disabled. HBE must be set high to reenable the 3-stated buffers.
LBE	2	Local Bus Enable. Same function as HBE for local data outputs.
LCE	1	Local Clock Enable. Enables all other local functions: clocks, frame groups, etc. (Note that the TCLKOUT is disabled during a Master Reset and is unaffected by HBE, LBE, or LCE, though there are control bits for this signal in the CKP register. See Section 2.5.8 Clock Control Register Definitions for a description of the CKP register.) 3-stated if disabled.
CB	0	CAM Busy. A status bit indicating microprocessor activity in any of the CAM blocks. A high means that one (or more) of the CAMs is being accessed by the microprocessor. In most cases, this bit will read low since there are many internal operational cycles dedicated to the microprocessor, which allow it to finish quickly.

2 Architecture and Functional Description (continued)

2.1 Register/Memory Maps (continued)

2.1.3 Address Mode Register

The AMR is defined in Table 10 below where (aaaa) is the stream address and the LAR is the time-slot address of the selected memory space.

Note: All unused AMR values are reserved.

Table 10. Address Mode Register

Bits 7—4	Bits 3—0	Register Function
0000	0000	Control Registers.
0001	(aaaa)	Local Bus, Data Memory 1.
0010	(aaaa)	Local Bus, Data Memory 2.
0100	(aaaa)	Local Bus, Connection Memory, Time-Slot Field.
0101	(aaaa)	Local Bus, Connection Memory, Stream, and Control Bit Field.
0111	0000	Local Bus, Holding Registers, Reset.
1001	0000	CAM, Data Memory 1. Lower 256 Addresses.
1001	0001	CAM, Data Memory 1. Upper 256 Addresses (T8102, T8105 only).
1010	0000	CAM, Data Memory 2. Lower 256 Addresses.
1010	0001	CAM, Data Memory 2. Upper 256 Addresses (T8102, T8105 only).
1011	0000	CAM, Connection, Time-Slot Field.
1011	0001	CAM, Connection, Stream, and Control Bit Field.
1011	0010	CAM, Connection, Tag Field.
1011	0011	CAM, Connection, Subrate Control, Tag Field MSB.
1110	0000	CAM, Even, Make Connection (MKCE). Write to Next Free Location.
1110	0001	CAM, Odd, Make Connection (MKCO). Write to Next Free Location.
1110	0011	CAM, Local, Make Connection (MKCL). Write to Next Free Location.
1110	0100	CAM, Even, Break Connection (BKCE).
1110	0101	CAM, Odd, Break Connection (BKCO).
1110	0111	CAM, Local, Break Connection (BKCL).
1110	1000	CAM, Even, Clear Location (CLLE). Lower 256 Range. Requires LAR.
1100	1000	CAM, Even, Clear Location (CLLE). Upper 256 Range. Requires LAR (T8102, T8105 only).
1110	1001	CAM, Odd, Clear Location (CLLO). Lower 256 Range. Requires LAR.
1100	1001	CAM, Odd, Clear Location (CLLO). Upper 256 Range. Requires LAR (T8102, T8105 only).
1110	1011	CAM, Local, Clear Location (CLLL). Lower 256 Range. Requires LAR.
1100	1011	CAM, Local, Clear Location (CLLL). Upper 256 Range. Requires LAR (T8102, T8105 only).
1110	1100	CAM, Even, Read Location (RDCE). Lower 256 Range. Requires LAR, IDR Holds Results.
1100	1100	CAM, Even, Read Location (RDCE). Upper 256 Range. Requires LAR, IDR Holds Results (T8102, T8105 only).
1110	1101	CAM, Odd, Read Location (RDCE). Lower 256 Range. Requires LAR, IDR Holds Results.
1100	1101	CAM, Odd, Read Location (RDCE). Upper 256 Range. Requires LAR, IDR Holds Results (T8102, T8105 only).
1110	1111	CAM, Local, Read Location (RDCL). Lower 256 Range. Requires LAR, IDR Holds Results.
1100	1111	CAM, Local, Read Location (RDCL). Upper 256 Range. Requires LAR, IDR Holds Results (T8102, T8105 only).
1111	0000	CAM, Even, Find Entry (FENE). IDR Holds Results.
1111	0001	CAM, Odd, Find Entry (FENO). IDR Holds Results.
1111	0011	CAM, Local, Find Entry (FENL). IDR Holds Results.
1111	1000	CAM, Even, Reset (RSCE).
1111	1001	CAM, Odd, Reset (RSCO).
1111	1011	CAM, Local, Reset (RSCL).
1111	1100	CAM, Holding Registers, Reset (RCH).
1111	1111	CAM, Initialize (CI). Reset All CAM Locations and Holding Registers.

2 Architecture and Functional Description (continued)

2.1 Register/Memory Maps (continued)

2.1.4 Control Register Memory Space

Function of LAR values when AMR = 0x00. All control registers reset to 0x00. All designations of MSB (most significant bit) and LSB (least significant bit) are shown.

Table 11. Control Register Memory Space

Register Address	Register Mnemonic	Description	Refer to Section
0, 0x00	CKM	Clocks, Main Clock Selections	2.5.8
1, 0x01	CKN	Clocks, NETREF Selections	2.5.8
2, 0x02	CKP	Clocks, Programmable Outputs	2.5.8
3, 0x03	CKR	Clocks, Resource Selection	2.5.8
4, 0x04	CKS	Clocks, Secondary (Fallback) Selection	2.5.8
5, 0x05	CK32	Clocks, Locals 3 and 2	2.5.8
6, 0x06	CK10	Clocks, Locals 1 and 0	2.5.8
7, 0x07	CKMD	Clocks, Main Divider	2.5.8
8, 0x08	CKND	Clocks, NETREF Divider	2.5.8
9, 0x09	CKRD	Clocks, Resource Divider	2.5.8
10—11, 0x0A—0x0B	(Reserved)	—	—
12, 0x0C	LBS	Local Stream Control	2.2.4
13, 0x0D	(Reserved)	—	—
14, 0x0E	CON	Connection Delay Type	Appendix B
15, 0x0F	(Reserved)	—	—
16, 0x10	HSL	H-Bus Stream Control, Low Byte	2.3.5
17, 0x11	HSH	H-Bus Stream Control, High Byte	2.3.5
18—22, 0x12—0x16	(Reserved)	—	—
23, 0x17	GPD	General-purpose Register, Direction Control	2.6.2
24, 0x18	GPR	General-purpose I/O Register	2.6.2
25—31, 0x19—0x1F	(Reserved)	—	—
32, 0x20	FRLA	Frame Group A, Start Address, Low	2.6.3
33, 0x21	FRHA	Frame Group A, High Address and Control	2.6.3
34, 0x22	FRLB	Frame Group B, Start Address, Low	2.6.3
35, 0x23	FRHB	Frame Group B, High Address and Control	2.6.3
36, 0x24	FRPL	Frame Group B, Programmed Output, Low	2.6.3
37, 0x25	FRPH	Frame Group B, Programmed Output, High	2.6.3
38—39, 0x26—0x27	(Reserved)	—	—
40, 0x28	CLKERR1	Clock Error Register, Error Indicator	2.7
41, 0x29	CLKERR2	Clock Error Register, Current Status	2.7
42, 0x2A	SYSERR	System Error Register	2.7
43, 0x2B	CKW	Clock Error/Watchdog Masking Register	2.5.7 & 2.7
44, 0x2C	CLKERR3	Clock Error Register, Current Status	2.7
45—47, 0x2D—0x2F	(Reserved)	—	—
48, 0x30	DIAG1	Diagnostics Register 1	2.9.2
49, 0x31	DIAG2	Diagnostics Register 2	2.9.2
50, 0x32	DIAG3	Diagnostics Register 3	2.9.2
51—253, 0x33—0xFD	(Reserved)	—	—
254, 0xFE	DEV_ID	Device Revision Status Register	3.2.1
255, 0xFF	GMODE	Global Mode Register	3.2.1

2 Architecture and Functional Description (continued)

2.1 Register/Memory Maps (continued)

2.1.4 Control Register Memory Space (continued)

This section is a summary of the register functions. The reader is encouraged to read through the rest of this specification to learn the details of the individual registers and their interactions with the overall architecture.

Table 12. CKM: Clocks, Main Clock Selection, 0x00

Bit	Description
7	Phase Alignment Enable
6	Phase Alignment Select
5	Compatibility Clock Direction
4	Input Clock Invert
3	Input Clock Select, MSB
2	Input Clock Select
1	Input Clock Select
0	Input Clock Select, LSB

Table 13. CKN: Clocks, NETREF Selections, 0x01

Bit	Description
7	NETREF1 Output Enable
6	NETREF2 Output Enable
5	Bypass Select
4	Input Clock Invert
3	Input Clock Select, MSB
2	Input Clock Select
1	Input Clock Select
0	Input Clock Select, LSB

Table 14. CKP: Clocks, Programmable Outputs, 0x02

Bit	Description
7	TCLK Select, MSB
6	TCLK Select
5	TCLK Select, LSB
4	CT_C8 Pins, Input Type Select
3	CT_C8A Output Enable
2	CT_C8B Output Enable
1	CT_C8 Pins, Output Type Select
0	/FR_COMP Pulse Width

Table 15. CKR: Clocks, Resource Selection, 0x03

Bit	Description
7	Resource Select, MSB
6	Resource Select, LSB
5	PLL #1 Bypass
4	PLL #1 Rate Select
3	PLL #2 Bypass
2	PLL #2 Rate Select
1	SCLK Output Select, MSB
0	SCLK Output Select, LSB

Table 16. CKS: Clocks, Secondary (Fallback) Selection, 0x04

Bit	Description
7	Secondary Resource Select, MSB
6	Secondary Resource Select, LSB
5	Fallback Type Select, MSB
4	Fallback Type Select, LSB
3	Fallback, Force Selection of Secondary Input
2	Secondary Input Clock Select, MSB
1	Secondary Input Clock Select
0	Secondary Input Clock Select, LSB

Table 17. CK32: Clocks, Locals 3 and 2, 0x05

Bit	Description
7	Local Clock 3 Select, MSB
6	Local Clock 3 Select
5	Local Clock 3 Select
4	Local Clock 3 Select, LSB
3	Local Clock 2 Select, MSB
2	Local Clock 2 Select
1	Local Clock 2 Select
0	Local Clock 2 Select, LSB

Table 18. CK10: Clocks, Locals 1 and 0, 0x06

Bit	Description
7	Local Clock 1 Select, MSB
6	Local Clock 1 Select
5	Local Clock 1 Select
4	Local Clock 1 Select, LSB
3	Local Clock 0 Select, MSB
2	Local Clock 0 Select
1	Local Clock 0 Select
0	Local Clock 0 Select, LSB

2 Architecture and Functional Description (continued)

2.1 Register/Memory Maps (continued)

2.1.4 Control Register Memory Space (continued)

Table 19. CKMD: Clocks, Main Divider; CKND: Clocks, NETREF Divider; CKRD: Clocks, Resource Divider, 0x07, 0x08, 0x09

Bit	Description
7	Divide Value, MSB
6	Divide Value
5	Divide Value
4	Divide Value
3	Divide Value
2	Divide Value
1	Divide Value
0	Divide Value, LSB

Table 20. LBS: Local Stream Control, 0x0C

Bit	Description
7	Parallel/Serial Select, MSB
6	Parallel/Serial Select, LSB
5	Local Group A Rate Select, MSB
4	Local Group A Rate Select, LSB
3	Local Group B Rate Select, MSB
2	Local Group B Rate Select, LSB
1	Local Group C Rate Select, MSB
0	Local Group C Rate Select, LSB

Table 21. CON: Connection Delay Type, 0x0E

Bit	Description
7	Reserved
6	Enable GPD (bitwise general-purpose register)
5	Select NETREF1/NETREF2 as main clock in.
4	L_REF type select (stand-alone or paired)
3	Invert L_REF Frame Strobe
2	Invert L_REF Bit Clock
1	Disable Connection-by-Connection Delay Setting
0	Global FME Setting

Table 22. HSL: H-Bus Stream Control, Low Byte, 0x10

Bit	Description
7	H-Bus Group D Rate Select, MSB
6	H-Bus Group D Rate Select, LSB
5	H-Bus Group C Rate Select, MSB
4	H-Bus Group C Rate Select, LSB
3	H-Bus Group B Rate Select, MSB
2	H-Bus Group B Rate Select, LSB
1	H-Bus Group A Rate Select, MSB
0	H-Bus Group A Rate Select, LSB

Table 23. HSH: H-Bus Stream Control, High Byte, 0x11

Bit	Description
7	H-Bus Group H Rate Select, MSB
6	H-Bus Group H Rate Select, LSB
5	H-Bus Group G Rate Select, MSB
4	H-Bus Group G Rate Select, LSB
3	H-Bus Group F Rate Select, MSB
2	H-Bus Group F Rate Select, LSB
1	H-Bus Group E Rate Select, MSB
0	H-Bus Group E Rate Select, LSB

Table 24. GPD, General-Purpose Direction Control Register, 0x17

Bit	Description
7	Direction Control for GPR Bit 7, 0 = In; 1 = Out.
6	Direction Control for GPR Bit 6, 0 = In; 1 = Out.
5	Direction Control for GPR Bit 5, 0 = In; 1 = Out.
4	Direction Control for GPR Bit 4, 0 = In; 1 = Out.
3	Direction Control for GPR Bit 3, 0 = In; 1 = Out.
2	Direction Control for GPR Bit 2, 0 = In; 1 = Out.
1	Direction Control for GPR Bit 1, 0 = In; 1 = Out.
0	Direction Control for GPR Bit 0, 0 = In; 1 = Out.

2 Architecture and Functional Description (continued)

2.1 Register/Memory Maps (continued)

2.1.4 Control Register Memory Space (continued)

Table 25. GPR: General-Purpose I/O Register, 0x18

Bit	Description
7	General-Purpose I/O, MSB
6	General-Purpose I/O
5	General-Purpose I/O
4	General-Purpose I/O
3	General-Purpose I/O
2	General-Purpose I/O
1	General-Purpose I/O
0	General-Purpose I/O, LSB

Table 26. FRLA: Frame Group A, Start Address Low, 0x20

Bit	Description
7	Start Address, Bit 7, or Programmed Output, Bit 7
6	Start Address, Bit 6, or Programmed Output, Bit 6
5	Start Address, Bit 5, or Programmed Output, Bit 5
4	Start Address, Bit 4, or Programmed Output, Bit 4
3	Start Address, Bit 3, or Programmed Output, Bit 3
2	Start Address, Bit 2, or Programmed Output, Bit 2
1	Start Address, Bit 1, or Programmed Output, Bit 1
0	Start Address, LSB, or Programmed Output, Bit 0

Table 27. FRHA: Frame Group A, High Address and Control, 0x21

Bit	Description
7	Rate Select, MSB
6	Rate Select, LSB
5	Pulse Width Select, MSB
4	Pulse Width Select, LSB
3	Frame Invert, or Programmed Output, Bit 11
2	Start Address, MSB, or Programmed Output, Bit 10
1	Start Address, Bit 9, or Programmed Output, Bit 9
0	Start Address, Bit 8, or Programmed Output, Bit 8

Table 28. FRLB: Frame Group B, Start Address Low, 0x22

Bit	Description
7	Start Address, Bit 7
6	Start Address, Bit 6
5	Start Address, Bit 5
4	Start Address, Bit 4
3	Start Address, Bit 3
2	Start Address, Bit 2
1	Start Address, Bit 1
0	Start Address, LSB

Table 29. FRHB: Frame Group B, High Address and Control, 0x23

Bit	Description
7	Rate Select, MSB
6	Rate Select, LSB
5	Pulse Width Select, MSB
4	Pulse Width Select, LSB
3	Frame Inversion Select
2	Start Address, MSB
1	Start Address, Bit 9
0	Start Address, Bit 8

2 Architecture and Functional Description (continued)

2.1 Register/Memory Maps (continued)

2.1.4 Control Register Memory Space (continued)

Table 30. FRPL: Frame Group B, Programmed Output, Low, 0x24

Bit	Description
7	Programmed Output, Bit 7
6	Programmed Output, Bit 6
5	Programmed Output, Bit 5
4	Programmed Output, Bit 4
3	Programmed Output, Bit 3
2	Programmed Output, Bit 2
1	Programmed Output, Bit 1
0	Programmed Output, Bit 0

Table 31. FRPH: Frame Group B, Programmed Output, High, 0x25

Bit	Description
7	Group A Output Pins Select, MSB
6	Group A Output Pins Select, LSB
5	(Reserved, Use 0)
4	Group B Output Pins Select
3	Programmed Output, Bit 11
2	Programmed Output, Bit 10
1	Programmed Output, Bit 9
0	Programmed Output, Bit 8

Table 32. CLKERR1: Clock Error Register, Error Indicator, 0x28

Bit	Description
7	C8A or Frame A Error
6	C8B or Frame B Error
5	/FR_COMPn Error
4	C16+ or C16- Error
3	C4n or C2 Error
2	SCLKX2 Error
1	SCLK Error
0	NETREF Error

Table 33. CLKERR2: Clock Error Register, Current Status, 0x29

Bit	Description
7	C8A or Frame A Fault Status
6	C8B or Frame B Fault Status
5	/FR_COMPn Fault Status
4	C16+ or C16- Fault Status
3	C4n or C2 Fault Status
2	SCLKX2 Fault Status
1	SCLK Fault Status
0	NETREF[2:1] Fault Status

Table 34. SYSERR: System Error Register, 0x2A

Bit	Description
7	Even CAM Underflow Error (No Match)
6	Odd CAM Underflow Error (No Match)
5	Local CAM Underflow Error (No Match)
4	Even CAM Overflow or No-Match Error
3	Odd CAM Overflow or No-Match Error
2	Local CAM Overflow or No-Match Error
1	H-Bus Data Memory Access Error
0	Fallback Enable Indicator

Table 35. CKW: Clock Error/Watchdog Masking Register, 0x2B

Bit	Description
7	C8A and Frame A Error Mask
6	C8B and Frame B Error Mask
5	/FR_COMP Error Mask
4	C16+ and C16- Error Mask
3	/C4 and C2 Error Mask
2	SCLKX2 Error Mask
1	SCLK Error Mask
0	NETREF1 Error Mask

Table 36. CLKERR3: Clock Error Register, Current Status, 0x2C

Bit	Description
7	(Reserved)
6	(Reserved)
5	NETREF2 Error
4	NETREF1 Error
3	(Reserved)
2	(Reserved)
1	(Reserved)
0	NETREF2 Error Mask

2 Architecture and Functional Description (continued)

2.1 Register/Memory Maps (continued)

2.1.4 Control Register Memory Space (continued)

Table 37. DIAG1: Diagnostics Register 1, 0x30

Bit	Description
7	Frame Group A Output Select, MSB
6	Frame Group A Output Select, LSB
5	Frame Group B Output Select, MSB
4	Frame Group B Output Select, LSB
3	Memory Fill Enable
2	Memory Fill Pattern Select, MSB
1	Memory Fill Pattern Select, LSB
0	Memory Fill Status Bit (Read Only)

Table 38. DIAG2: Diagnostics Register 2, 0x31

Bit	Description
7	Frame Groups Cycle Test Enable
6	Break State Counter into Subsections
5	Bypass Internal Frame with /FR_COMPn
4	(Reserved)
3	Enable State Counter Parallel Load
2	Parallel Load Value of State Counter, MSB
1	Parallel Load Value of State Counter, Bit 9
0	Parallel Load Value of State Counter, Bit 8

Table 39. DIAG3: Diagnostics Register 3, 0x32

Bit	Description
7	Parallel Load Value of State Counter, Bit 7
6	Parallel Load Value of State Counter, Bit 6
5	Parallel Load Value of State Counter, Bit 5
4	Parallel Load Value of State Counter, Bit 4
3	Parallel Load Value of State Counter, Bit 3
2	Parallel Load Value of State Counter, Bit 2
1	Parallel Load Value of State Counter, Bit 1
0	Parallel Load Value of State Counter, LSB

Table 40. DEV_ID: Device Identification Register, 0xFE

Bit	Description
7	Device Identification Number, MSB
6	Device Identification Number
5	Device Identification Number
4	Device Identification Number, LSB
3	Device Version Number, MSB
2	Device Version Number
1	Device Version Number
0	Device Version Number, LSB

Table 41. GMODE: Global Mode Register, 0xFF

Bit	Description
7	Mode Emulation Set 2 (ME2)
6	Mode Emulation Set 1 (ME1)
5	Subrate Enable (SE)
4	(Reserved)
3	EMUL, MSB
2	EMUL
1	EMUL
0	EMUL, LSB

2 Architecture and Functional Description (continued)

2.2 Local Bus Section

Figure 4 shows the local bus section function diagram.

Note: Routing and MUXing for the H-bus section is included since the H-bus requires access to the converters for local bus-to-H-bus or H-bus-to-local bus transfers (the H-bus is discussed in Section 2.3 H-Bus Section).

XCS is a pseudo serial stream, read out from the connection memory on each memory access. It is read out directly, i.e., not passing through any parallel/serial converters or holding registers, so it precedes the connection associated with it by one time slot.

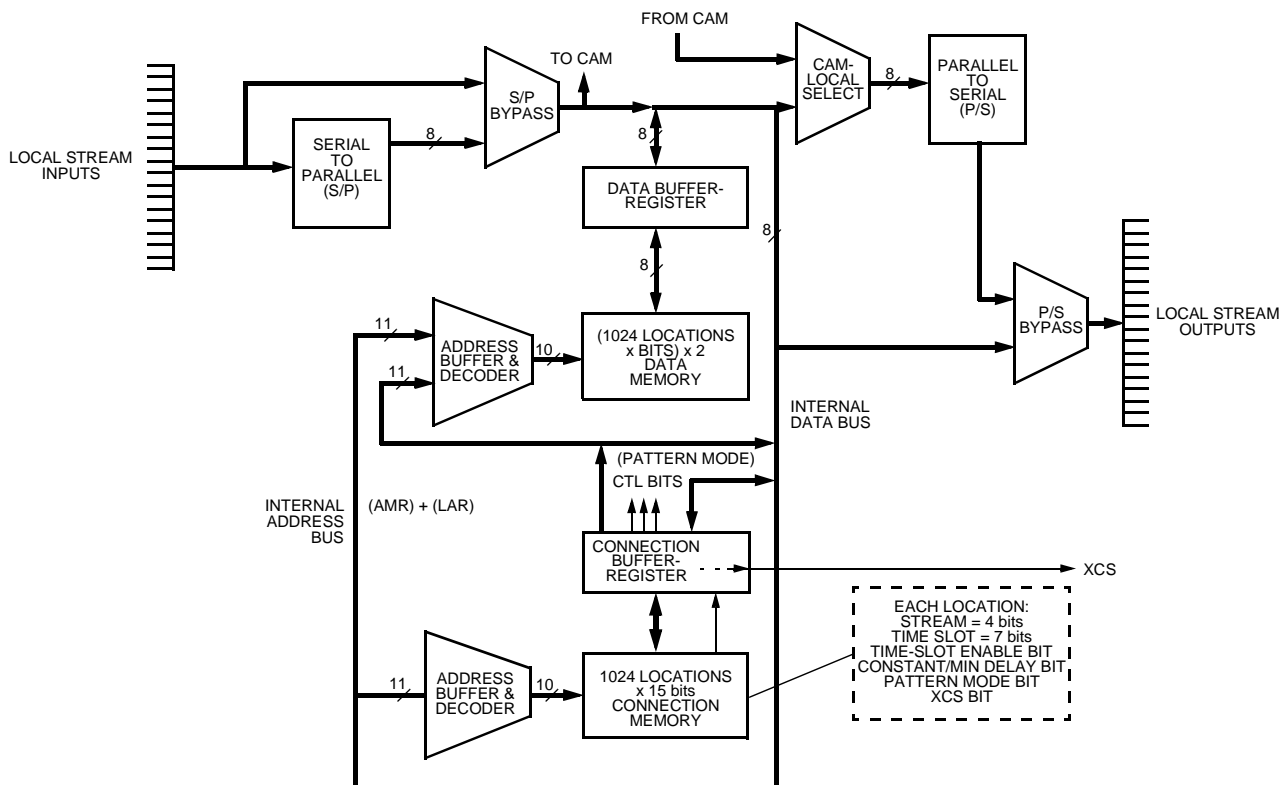

5-6102F

Figure 4. Local Bus Section Function

All of the *Ambassador* family TSIs have a local bus, but only the T8100A and T8105 have local connection memory and local data memory for time-slot interchanging.

2 Architecture and Functional Description (continued)

2.2 Local Bus Section (continued)

2.2.1 Constant Frame Delay and Minimum Delay Connections

The local bus section contains the local connection memory (T8100A, T8105 only) and the double-buffered local data memory. Collectively, the connection memory and data memory are referred to as local memory since it is used for implementing local-to-local switching only. Operation is similar to other time-slot interchangers. Data is written into the memory in a fixed order and then read out according to the indirect addresses held in the connection memory. If any of the connections on the devices are operating in constant frame delay (also called constant delay) mode, then the output data is accessed from a second block of data memory. The input data will not be output until the next frame boundary has been crossed and the memory blocks have swapped functions. Figure 5 shows an example of a set of connections which create the delay types referred to as minimum delay and constant delay.

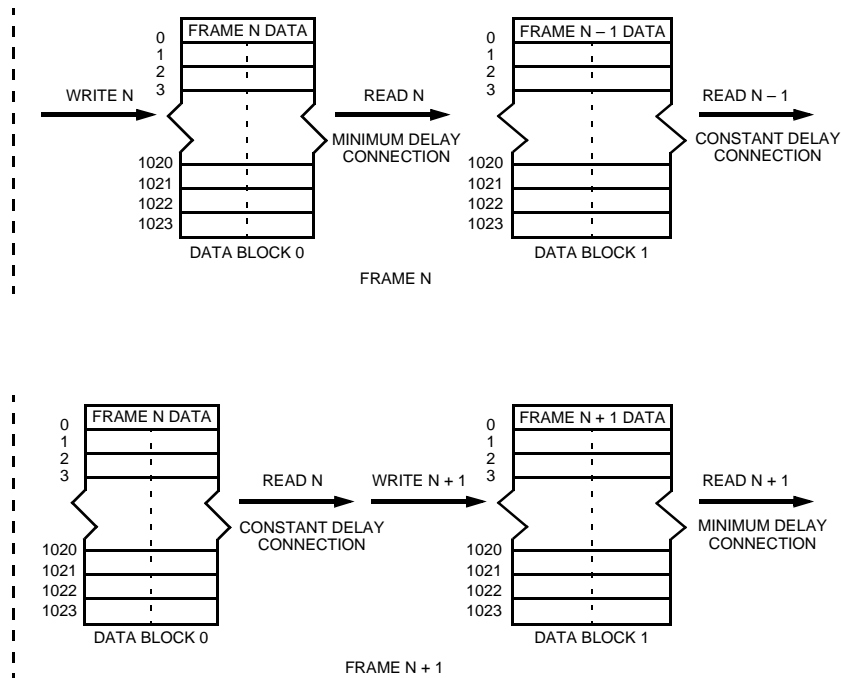

5-6103F

Figure 5. Local Bus Memory Connection Modes

2.2.2 Serial and Parallel

Nominally, the memory will be accessed by serial data streams which will require conversion of serial-to-parallel (S/P) for write accesses and parallel-to-serial (P/S) for read accesses. Since the local memory can have up to 16 serial inputs and 16 serial outputs, there will be a maximum of 16 S/P converters and 16 P/S converters operating simultaneously. If desired, eight of the S/P converters, local inputs 0—7, can be bypassed for a direct parallel write to the data memory. Likewise, eight of the P/S converters, local outputs 0—7, can be bypassed for a direct parallel read of the data memory. Unused S/P or P/S converters are nonfunctional in these modes.

Note: The normal serial-to-serial local streaming is not available simultaneously with any of the parallel modes.

2 Architecture and Functional Description (continued)

2.2 Local Bus Section (continued)

2.2.3 Data Rates and Time-Slot Allocation

At its maximum, the T8100A and the T8105 will be able to process 1024 nonblocking local-to-local connections. The data rate 8.192 Mbits/s corresponds to 128 time slots, 4.096 Mbits/s corresponds to 64 time slots, and 2.048 Mbits/s corresponds to 32 time slots. Since different data rates require different amounts of memory, the local memory can be filled in a number of ways. A non-blocking switch permits any time slot on any stream to be switched to another time slot on any stream in any direction.

The local streams are arranged in three groups: A, B, and C. Group A corresponds to the local data pins 0—7, group B with local data pins 8—11, and group C with local data pins 12—15. The groups may be operated at any of the three data rates: 2.048 Mbits/s, 4.096 Mbits/s, or 8.192 Mbits/s; however, group B is activated only when group A is operating below 8.192 Mbits/s. Likewise, group C is activated when group B is operating below 8.192 Mbits/s.

Note: In order to efficiently fill the memory, the memory locations are read or filled in the same order regardless of their activation or rate.

The streams are scanned in intervals equal to 8.192 Mbits/s time slots: first group A from 0 through 7, then group B from 8 through 11, then group C from 12 through 15. If a group is active, the data is input from or output to the streams in that group. If a group is operating below 8.192 Mbits/s and has already been scanned (at the 8.192 Mbits/s rate), then the data transfer operation is ignored.

For addressing, the user directly provides stream and time-slot information. The devices will map this into the physical memory, regardless of which stream groups are active or at what rate. While this makes programming simpler, it makes the internal operation more difficult to understand. Several diagrams are required to illustrate how the memory utilization works.

Unassigned time slots in the local output section are 3-stated. Therefore, multiple lines can be connected together.

Figure 6 below shows the overall structure of the local memory:

Note: Both the connection and two data memories are arranged in four blocks of 256 locations each (i.e., $4 \times [4 \times 64]$).

The arrangement is important to establishing a memory fill pattern which supports all of the various groups and rates. The rows of each memory, which are split into four groups of 4, correspond to the 16 streams. The columns correspond to 64 time-slot addresses.

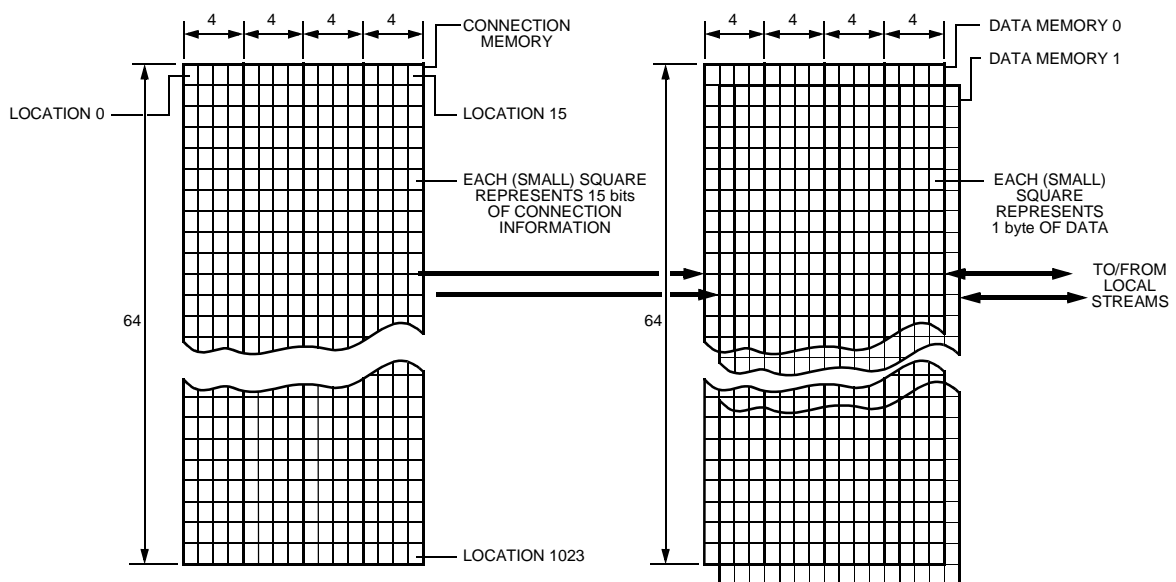

5-6104F

Figure 6. Local Streams, Memory Structure

2 Architecture and Functional Description (continued)

2.2 Local Bus Section (continued)

2.2.3 Data Rates and Time-Slot Allocation (continued)

Examples of how the memory is filled are found in Figure 7.

Note: Again, the user needs only to provide stream and time-slot addresses; the devices will generate the internal memory addresses.

Both the connection and data memories are filled using the same algorithm. In the case where group C is running at 8.192 Mbits/s, group B is at 4.096 Mbits/s (or 2.048 Mbits/s), and group A is at 2.048 Mbits/s, then an additional virtual memory space of 4 x 64 locations is created from unused locations in other parts of the memory.

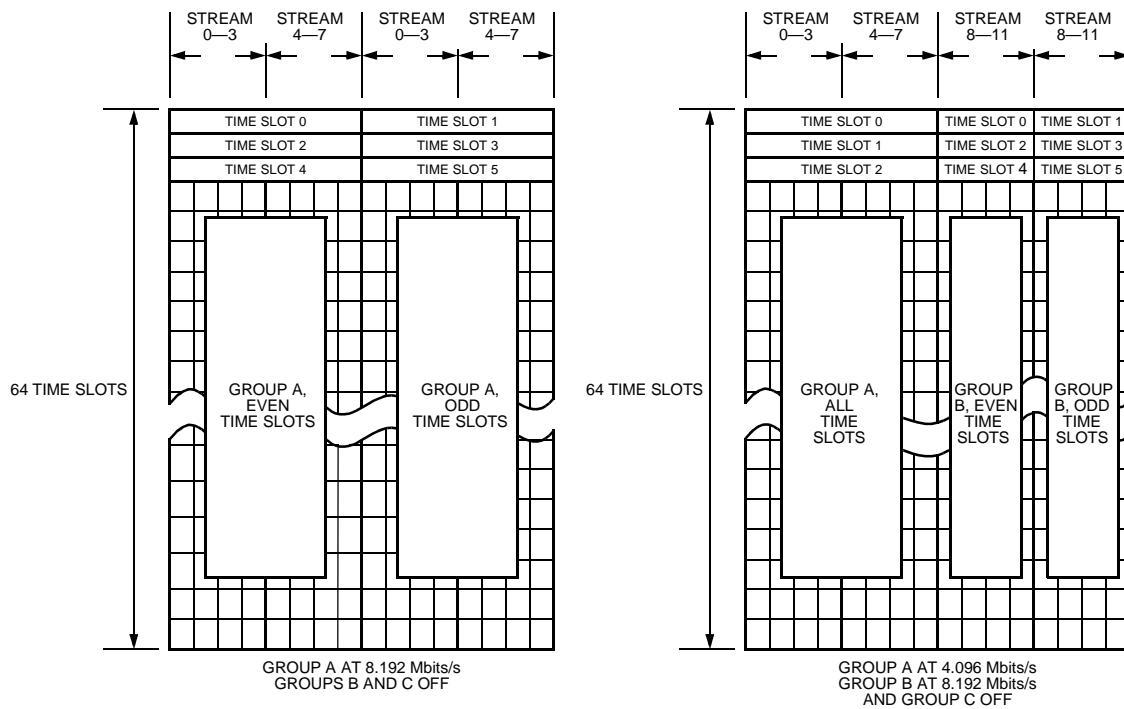

5-6105F

Figure 7. Local Memory (T8100A, T8105 Only), Fill Patterns

2 Architecture and Functional Description (continued)

2.2 Local Bus Section (continued)

2.2.3 Data Rates and Time-Slot Allocation (continued)

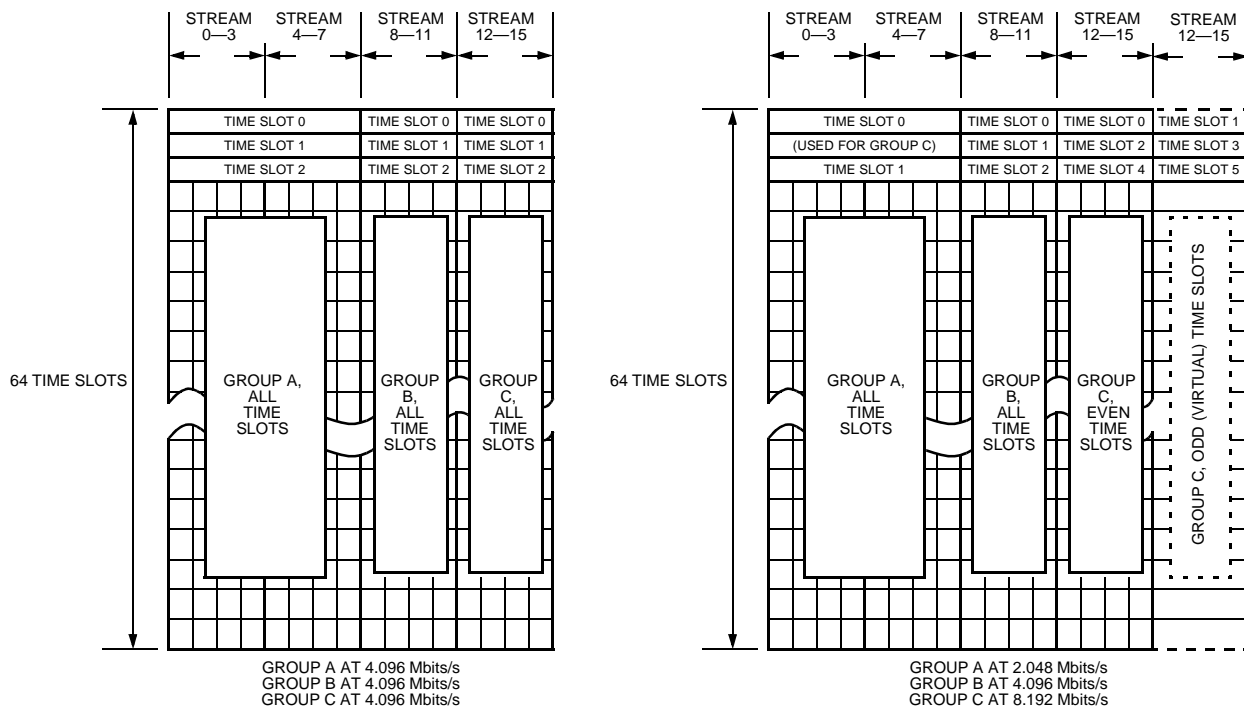

5-6106F

Figure 7. Local Memory (T8100A, T8105 Only), Fill Patterns (continued)

In any of the parallel modes (S/P, P/S, P/P), the local memories (T8100A, T8105 only) treat parallel data as a series of sequential time slots (i.e., all one stream): 8.192 Mbits/s corresponds to 1024 time slots, 4.096 Mbits/s corresponds to 512 time slots, and 2.048 Mbits/s corresponds to 256 time slots. The memory locations are scanned in order from 0 to 1023 at 8.192 Mbits/s, even locations are scanned at 4.096 Mbits/s (odd locations are skipped), and at 2.048 Mbits/s, every second even location is scanned.

2 Architecture and Functional Description (continued)

2.2 Local Bus Section (continued)

2.2.4 LBS: Local Stream Control, 0x0C

The normal mode of operation for local streams is serial in/serial out, but parallel modes are available. Modes and data rates are controlled by register LBS. The mapping is shown below. See the preceding pages for a full description.

Table 42. LBS: Local Stream Control, 0x0C

Reg	R/W	Bit 7	Bit 6	Bit 5	Bit 4	Bit 3	Bit 2	Bit 1	Bit 0
LBS	—	P/S		SGa		SGb		SGc	

Symbol	Bit	Description
P/S	7—6	P/S = 00. Serial In/Serial Out. The SGa bits control the group A pins, SGb bits control the group B pins, and SGc bits control the group C pins. As serial streams, input and output rates within the same group are constrained to be identical so both inputs and outputs share the same 2 bits for programming. The SGb bits are enabled when SGa ≠ 11. The SGc bits are enabled when SGb ≠ 11.
		P/S = 01. Serial In/Parallel Out. SGa sets input (serial) rate using the rate definition within this table. SGb is reserved. SGc sets the output (parallel) rate using the rate definition within this table.
		P/S = 10. Parallel In/Serial Out. SGa sets input (parallel) rate. SGb is reserved. SGc sets output (serial) rate.
		P/S = 11. Parallel In/Parallel Out. SGa sets input (parallel) rate. SGb is reserved. SGc sets output (parallel) rate.
SGa	5—4	SGa = 00, 3-state. SGa = 01, 2.048 Mb/s. SGa = 10, 4.096 Mb/s. SGa = 11, 8.192 Mb/s.
SGb	3—2	SGb = 00, 3-state. SGb = 01, 2.048 Mb/s. SGb = 10, 4.096 Mb/s. SGb = 11, 8.192 Mb/s.
SGc	1—0	SGc = 00, 3-state. SGc = 01, 2.048 Mb/s. SGc = 10, 4.096 Mb/s. SGc = 11, 8.192 Mb/s.

There are no additional registers required for addressing the local memory other than the main address registers (discussed in Section 2.1 Register/Memory Maps). The data and connection memory locations (T8100A, T8105 only) can be queried for their contents by indirect reads through the main address registers; however, the memory locations are referred to by the stream and time-slot designators, rather than physical address locations, to simplify the queries.

2 Architecture and Functional Description (continued)

2.2 Local Bus Section (continued)

2.2.5 State Counter Operation

All operations are synchronized to the master state counter. The state counter is, in turn, synchronized to the internal frame signal and driven by an internal 65.536 MHz clock. In normal operation, the internal frame and clock are synchronized to either the H-bus or trunks (see Section 2.5 Clocking Section for a more detailed explanation of clocking options). The local memory states (T8100A, T8105 only) are illustrated in Figure 8. The state counter is a modulo-8192 counter (7 bits for time slot, 4 bits for stream, 2 bits for state function) which can also be reset and loaded with other values for diagnostic purposes (as described in Section 2.9 Testing and Diagnostics). The H-bus memories are also referenced to this state counter so that the devices maintain synchronization with the H-bus to ensure proper access to the bus as well as ensure synchronization between the H-bus and local memory structures. The H-bus memories are discussed in Section 2.3 H-Bus Section.

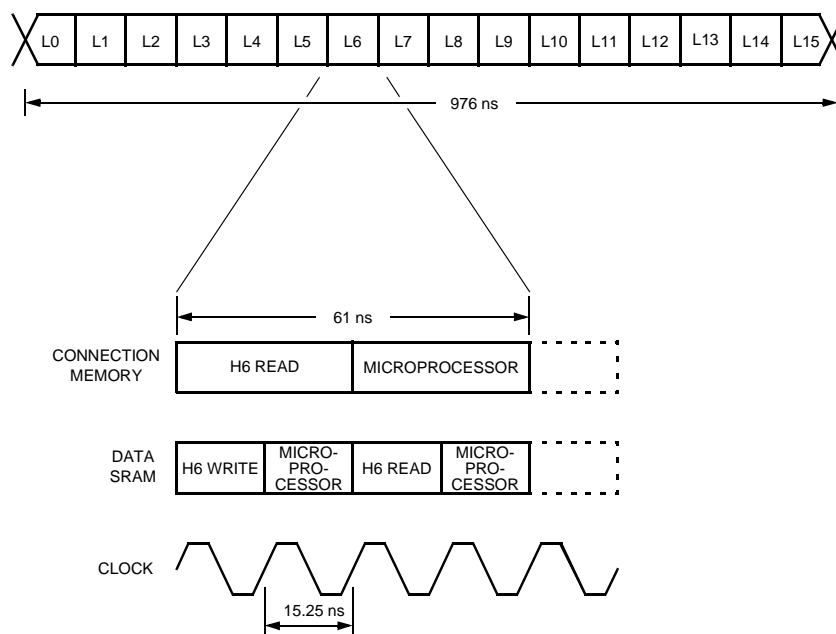

5-6107F

Figure 8. Simplified Local Memory State Timing, 65.536 MHz Clock

2.2.6 Software to Reset the Local Connection Memory

When the device is powered up, random connections may exist. To clear the upper 6 bits and, therefore, all control bits, the following sequence of instructions should be followed:

1. Write AMR = 0x00.
2. Write LAR = 0x30.
3. Write IDR = 0x0C.
4. Monitor Diag-1, 0x30, bit 0. This bit is set when the operation is complete (steps 1 through 3).
5. Write LAR = 0x30.
6. Write IDR = 0x00. This brings the device out of diagnostics mode.

After executing the instructions, the contents of the local connection memory will contain its corresponding 10-bit address. The upper 6 bits are cleared to zero. The lower 10 bits will have an address.

2 Architecture and Functional Description (continued)

2.3 H-Bus Section

2.3.1 Memory Architecture

To access the H-bus, the devices use a new twist on an existing approach to accessing large address spaces: the data is stored in an independent double-buffered SRAM which acts like the local data memory, but the connection information for the H-bus is held in three 512 location CAMs (T8102, T8105 only). Two CAMs are used for two groups of 16 H-bus streams each, and one CAM for all 16 local input/output pairs. Each CAM compares 16 streams for read and write and allows access time to the host microprocessor for updates to the connections. Thus, each stream is allotted three operations per 976 ns time slot, so there are a maximum of 48 accesses per CAM per time slot. The CAMs must operate at a rate of at least 20.34 ns/access*. The selected technology operates at 13 ns/access maximum, so an internal clock speed of 15.26 ns (65.536 MHz) is used.

For the following discussions, the reader should refer to Figure 9. The combined comparison plus retrieval operations take two CAM cycles, leaving little time for microprocessor updates. To circumvent this, a separate SRAM (actually, a register file) is tied to each CAM. Each entry of this register file is associated with an

entry in the CAM on a location-by-location basis. (For example, physical address 0xA7 in the CAM is coupled with physical address 0xA7 of the register file.) The CAMs will have only the comparand field for stream and time-slot addresses, and the associated register files will hold the data field, which is comprised of a tag (an indirect pointer to the double-buffered data SRAM) and some control bits. Using the associated SRAM allows the operations to be pipelined so that the data retrieval occurs while the CAMs are doing the next comparison. The SRAM is double-buffered to permit constant delay or minimum delay on a connection-by-connection basis, as described in Section 2.2.1 Constant Frame Delay and Minimum Delay Connections, and as illustrated in Figure 5.

* The H-bus presents a unique set of problems. A full nonblocking, double-buffered switch of 5120 locations has significant barriers in size and in control of memory access time. Further, the traffic between the local bus and H-bus is generally limited to a small number of time slots at any given moment (120 full duplex is typical, although we are permitting 256 duplex or 512 (T8102, T8105 only) simplex connections), but the requirement to access any time slot out of the full range of 5120 locations remains. To solve this, content addressable memories (CAM) are utilized. They provide access to the full 5120 locations through an encoded width (13 bits), but require a depth equal to the maximum number of connections required (512 [T8102, T8105 only]).

2 Architecture and Functional Description (continued)

2.3 H-Bus Section (continued)

2.3.1 Memory Architecture (continued)

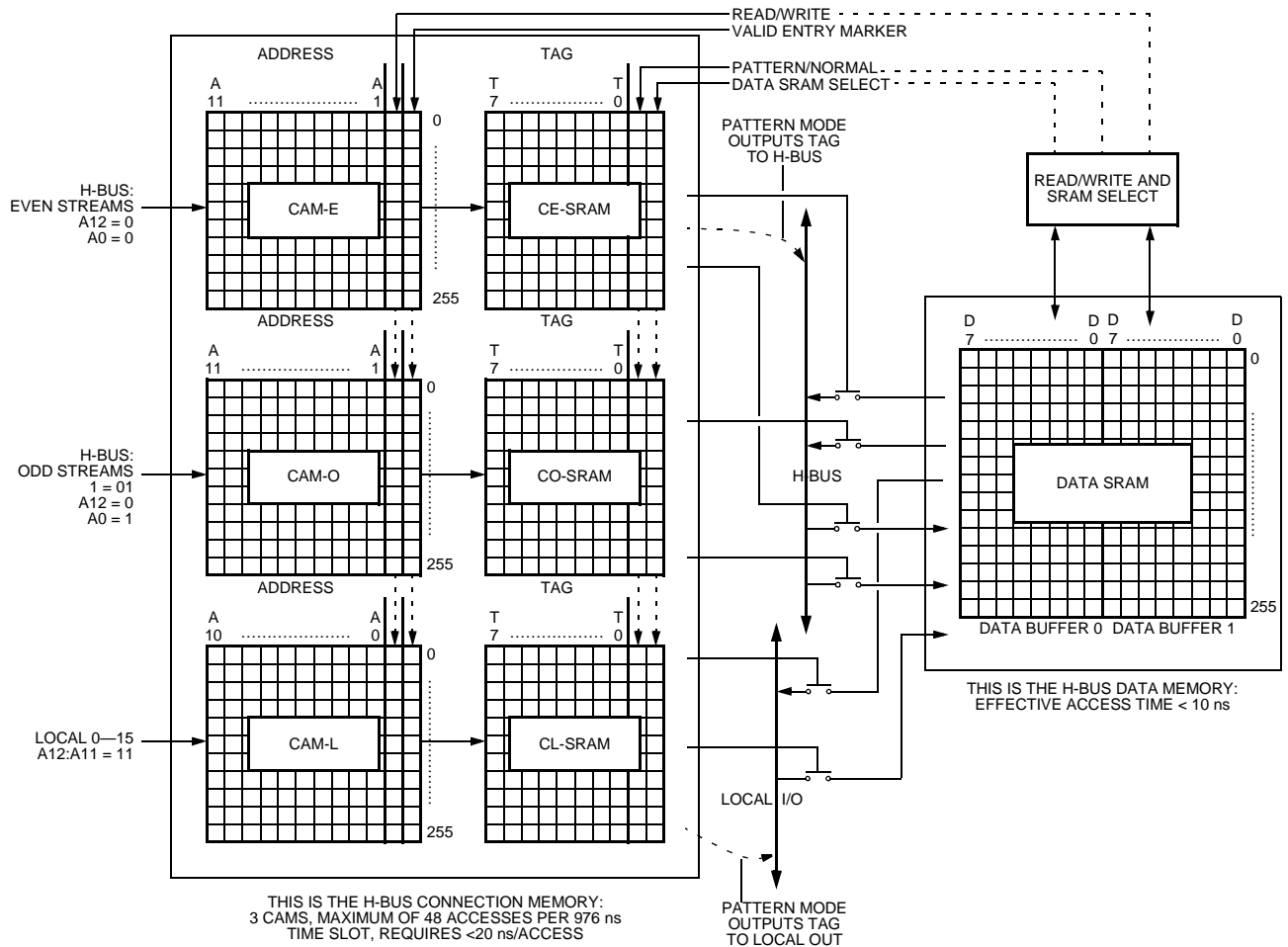

5-6108F

Figure 9. CAM Architecture

The maximum number of connections is set by the number of locations in the data SRAM and the CAMs. In this implementation, 512 simplex (T8102, T8105 only) connections are permitted. Since one connection requires two CAM entries pointing to a common data location, the maximum number of connections could be reduced to 256 simplex if all connection entries reside within only one CAM. The maximum number of connections is increased above 512 simplex if the connection type is broadcast, i.e., from one to many.

2 Architecture and Functional Description (continued)

2.3 H-Bus Section (continued)

2.3.2 CAM Operation and Commands

The three CAMs operate in parallel. Each CAM's comparand field is compared with the state counter (Section 2.2.5 State Counter Operation) which holds the existing stream and time-slot value*. If there is a match, the CAM issues a hit. If there is more than one match, then it is considered a multiple hit. Likewise, no match is a miss. As a part of the state counter, a bit is toggled for read/write. The read/write bit is stored in the CAM, so it becomes part of the value to be compared. If the comparison for a write yields a hit, then there is a request for write access to the data memory for the incoming data from the H-bus. If the comparison for a read yields a hit, then there is a request for a read access from the data memory for outgoing data to the H-bus. A miss implies no action. Any multiple hit within one CAM block is treated as a controlled error although it is not reported. The action taken is to acknowledge the hit which corresponds to the lowest physical address of the CAM. A multiple hit is assigned to be

more than one valid connection. These are prioritized such that the match with the lowest physical address (i.e., closest to CAM location 0x0) is the address which is processed. Thus, errors are handled in a controlled manner. Multiple hits can occur because multiple locations are assigned to the same time slot. Good software and careful coding can help avoid this problem. A controlled error has no impact on performance, and the CAM contents are not changed as a result of the error. The data SRAMs are actually dual-port register files which will process both writes and reads on each clock cycle of the clock. The devices can process a read and write request from each CAM and two microprocessor requests during the time of one address comparison. Due to the fixed order of operations, the data SRAM cannot overflow or underflow like the CAMs. The timing is shown in Figure 10.

* As mentioned in Section 2.2.5 State Counter Operation, for each stream and time-slot value, the state counter goes through four functional states for each stream and time slot. These states are used to synchronize the CAMs, pipeline register files, data SRAMs, and microprocessor accesses just as they are used to synchronize local memory operations and the frame groups. (Microprocessor accesses to the memories are initiated asynchronously, though the actual microprocessor cycles are synchronous.)

2 Architecture and Functional Description (continued)

2.3 H-Bus Section (continued)

2.3.2 CAM Operation and Commands (continued)

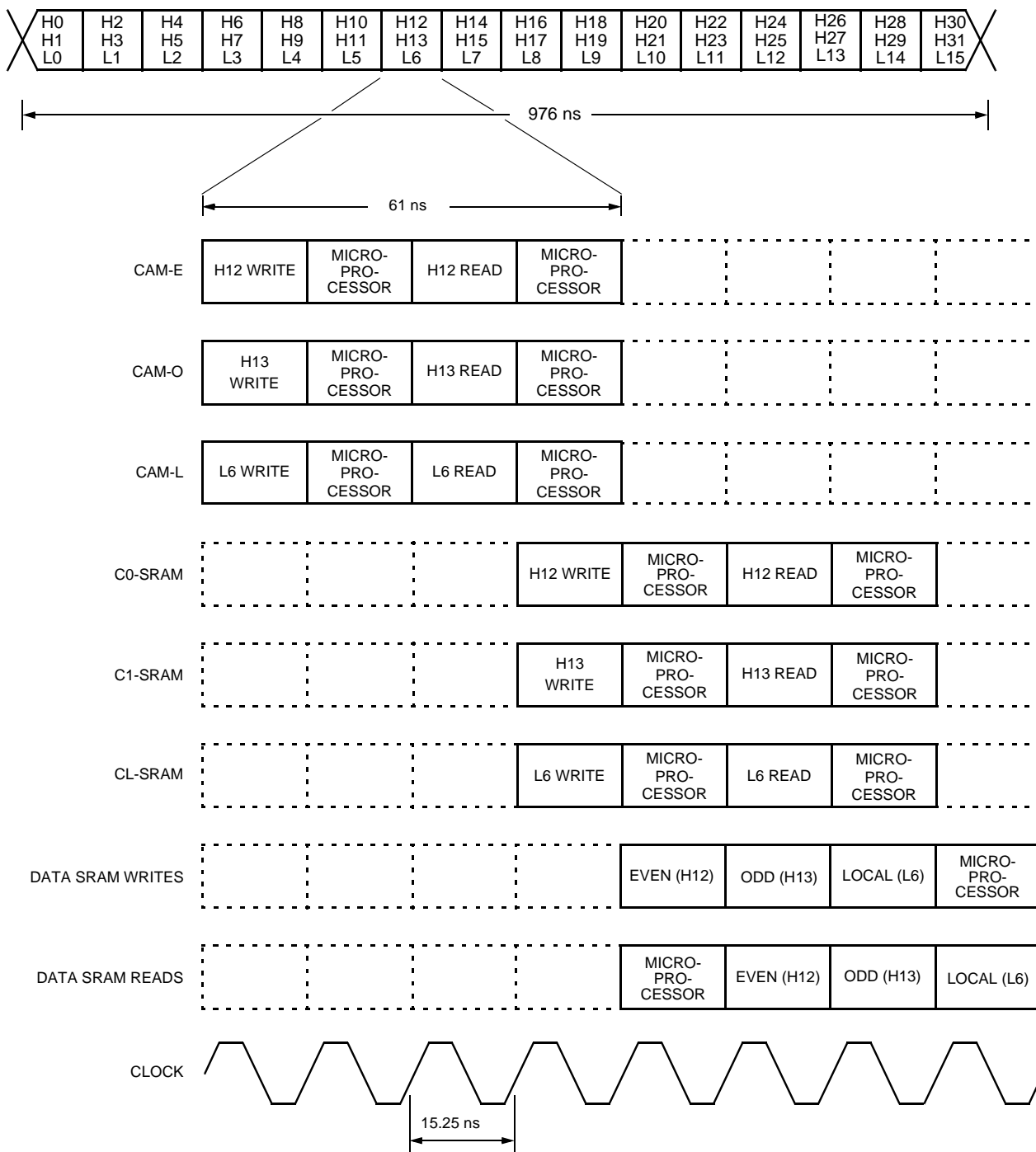

5-6109F

Figure 10. Simplified H-Bus State Timing, 65.536 MHz Clock

2 Architecture and Functional Description (continued)

2.3 H-Bus Section (continued)

2.3.2 CAM Operation and Commands (continued)

A number of commands are available to control the CAMs. Connections can be made or broken, entry data can be searched for, individual locations may be read or cleared, or the CAMs can be reset. The address mode register (AMR) (see Section 2.1 Register/Memory Maps) is used to issue the CAM control commands. Some commands require the use of the lower address register (LAR), and some use the IDR as a transfer register.

The tags in each CAM's associated register file reference the storage location of the data being transferred, so each CAM/tag location also has control information. The three control bits are read-to/write-from data SRAM (i.e., a direction bit, located in the CAM and used during the comparison operations), a pattern mode enable, which bypasses the data SRAM and outputs the tag directly into the specified time slot for writes to the bus, and an SRAM buffer select that controls the minimum delay or constant delay select, equivalent to the local memory's (T8100A, T8105 only) selection of minimum or constant delay.

In addition, the CAM carries a valid entry bit. This is an identifier for the status of the CAM (and corresponding register file) location. If the bit is low, as all validity bits are after a reset, then the location is available to be written into. When data is written into a location, then this bit is set, indicating that this is a valid entry. If specific data is no longer valid, such as when a connection is broken, then the bit is cleared.

The CAM commands make use of either one or two cycles. The two cycles are described pictorially in Figure 11. The reader will note that matching and retrieval are actually separate cycles. The need for two cycles accounts for the requirement of the pipeline register files.

Detailed descriptions of the commands follow:

The basic make connection command is referred to as MKCn, where n is the CAM designator*. The MKCn uses two CAM cycles: first, the CAM is searched to determine where to find the next free location (as determined by the validity bits), and during the second cycle, the next empty location is written into. The MKCn command uses holding registers which convey the connection information to the CAM and its associated register file. The four holding registers contain the lower connection address (i.e., time slot), the upper connection address (stream plus control bits), the tag LSBs, the subrate control (7 bits), and the tag MSB. An attempt to write to a full CAM (all 512 locations fully occupied in the T8102 and T8105) results in an overflow error flagged through the system error register, SYSERR (see Section 2.7 Error Registers).

Note: A single MKCn command only specifies one-half of a connection. The MKCn specifies the connection address and a pointer to the data memory, but a second connection address and pointer to the same data memory location must also be provided for a complete connection.

* The H-bus CAM covering the 16 even-numbered H-bus streams is designated E, the H-bus CAM covering the 16 odd-numbered H-bus streams is designated O, and the CAM that services the 16 local stream pairs is designated L.

2 Architecture and Functional Description (continued)

2.3 H-Bus Section (continued)

2.3.2 CAM Operation and Commands (continued)

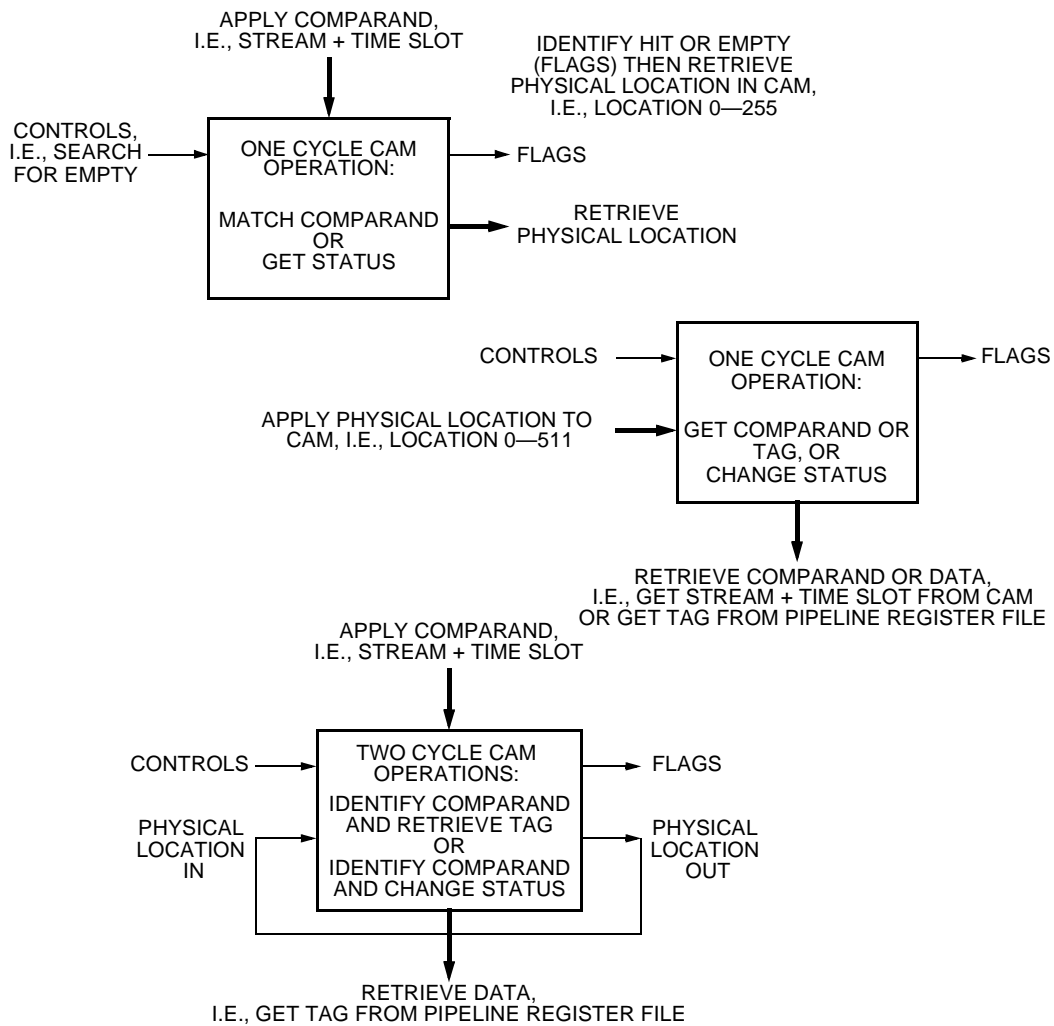

5-6110.cF

Figure 11. Illustration of CAM Cycles

2 Architecture and Functional Description (continued)

2.3 H-Bus Section (continued)

2.3.2 CAM Operation and Commands (continued)

If the user determines that a stream/time slot is no longer valid, then the validity bit may be cleared by presenting the connection address to the CAM and by using the BKCn, break connection, command. The connection that the user intends to break, which consists of the time slot, and the stream plus control bits, but not the tag, is transferred to the holding registers prior to issuing this command. This is a two-cycle command: during the first cycle, the connection address is presented to the CAM to identify which physical location holds that connection address, and then, in the second cycle, the validity bit is cleared for the identified physical location. If there is a miss, it flags a no-match error through the underflow bit in SYSERR.

Note: A complete connection break requires two BKCn commands, one for each half of the connection, as with the MKCn command.

The clear location (upper/lower) command, CLLn, is a one-cycle command. The LAR contains the physical address (i.e., the physical CAM location) to be cleared (when AMR bit 5 equals 1, the lower bits, 0—255, are cleared; when 0, the upper bits, 256—511, are cleared). When it is presented to the CAM, the validity bit is cleared, returning the location to an empty status (i.e., it becomes available for new make connection commands). The CLLn can also be regarded as the second cycle of a break connection command. CLLn is valuable if several outputs are driven from a common input (broadcast) and the user wishes to break one of the output connections, but leave the others intact. When the physical location in the CAM is identified, either by software tracking or by use of the find entry command (later in this section), then the CLLn can be issued.

If the user wishes to poll the CAM for its contents, then the RDCn or read CAM (upper/lower) command can be used to query a particular location (AMR bit 5: when 1, equals 0—255, when 0, equals 256—511 [T8102, T8105 only]) in a specific block using the LAR for the location address. The contents of the CAM and tag location are transferred to the holding registers, and then the time slot, stream plus control, and tag are returned (in sequence) from four consecutive IDR reads (see Section 3.4.2 Setting Up H-Bus Connections on page 75 for more details). The MSB of the time slot is the validity bit. The actual RDCn operation is one-cycle.

The converse of the RDCn is the FENn, or find entry command. It can be thought of as the first cycle of a BKCn command. Only time slot and stream plus control bits are necessary for identifying the location. The tag is not needed. The values returned (in sequence) from two consecutive IDR reads (T8102, T8105 only) or just one read (T8100A) (see Section 3.4.2 Setting Up H-Bus Connections on page 75 for more details) to the IDR is the physical location of the entry in the CAM block, bits [7:0] then bit 8, if it is found. If the entry is not found, then the underflow error bit in the SYSERR register will be set. FENn is a one-cycle command.

RSCn is the reset CAM command, and this renders all locations in one CAM block invalid. This can be considered a CLLn for all locations in the CAM. Two special resets are the RCH command, which resets only the holding registers, and the CI command, which resets all three CAM blocks and the holding registers. All resets are one-cycle.

2.3.3 H-Bus Access

There are 32 bidirectional pins available for accessing the H-bus. The direction of the pins is selected by the CAM read and write bits. Data rates for the pins are selected in accordance with the H.100/H.110 specifications. Unassigned time slots on the H-bus are 3-stated. Details about rate selection are provided below. Two bits of the 13-bit address are used to select the CAM block as indicated in Figure 9. The remaining 11 bits plus a read/write bit form a comparand that is stored in a CAM location.

2 Architecture and Functional Description (continued)

2.3 H-Bus Section (continued)

2.3.4 L-Bus Access

The input and output of the CAM have the appropriate links to the local stream pins so that the H-bus streams may be routed to and from the local bus streams. The LBS register (Section 2.2.4 LBS: Local Stream Control, 0x0C) programs the local stream rates even if accessed by the CAMs. To address the local bus CAM block, the two most significant address bits of the physical address are set to the appropriate values as described in Figure 9. The other bits form the comparand along with a read/write bit. When the CAM is outputting data to the local bus, it has priority over the local bus memory. In other words, if both the local bus and H-bus access the same local stream and time slot, the H-bus data memory will provide the actual data, not the local connection.

2.3.5 H-Bus Rate Selection and Connection Address Format

Operating rates are selected in a manner similar to the local side. Two registers, HSH and HSL, shown below, define the operation of the 32 streams. Again, SGx refers to stream groups: HSH holds SGh—SGe where SGh programs streams 28—31, SGg programs streams 24—27, SGf programs streams 20—23, and SGe programs streams 16—19. HSL holds SGd—SGa where SGd programs streams 12—15, SGc programs streams 8—11, SGb programs streams 4—7, and SGa programs streams 0—3.

Table 43. HSL: H-Bus Stream Control, Low Byte, 0x10

Reg	R/W	Bit 7	Bit 6	Bit 5	Bit 4	Bit 3	Bit 2	Bit 1	Bit 0
HSL	—	SGd		SGc		SGb		SGa	

Symbol	Bit	Description		
SGd	7	H-Bus Group D Rate Select, MSB.	Programs streams 12—15.	SGn = 00, 3-state SGn = 01, 2.048 Mbits/s SGn = 10, 4.096 Mbits/s SGn = 11, 8.192 Mbits/s
	6	H-Bus Group D Rate Select, LSB.		
SGc	5	H-Bus Group C Rate Select, MSB.	Programs streams 8—11.	
	4	H-Bus Group C Rate Select, LSB.		
SGb	3	H-Bus Group B Rate Select, MSB.	Programs streams 4—7.	
	2	H-Bus Group B Rate Select, LSB.		
SGa	1	H-Bus Group A Rate Select, MSB.	Programs streams 0—3.	
	0	H-Bus Group A Rate Select, LSB.		

2 Architecture and Functional Description (continued)

2.3 H-Bus Section (continued)

2.3.5 H-Bus Rate Selection and Connection Address Format (continued)

Table 44. HSH: H-Bus Stream Control, High Byte, 0x11

Reg	R/W	Bit 7	Bit 6	Bit 5	Bit 4	Bit 3	Bit 2	Bit 1	Bit 0
HSL	—	SGh		SGg		SGf		SGe	

Symbol	Bit	Description		
SGh	7	H-Bus Group H Rate Select, MSB.	Programs streams 28—31.	SGn = 00, 3-state SGn = 01, 2.048 Mbits/s SGn = 10, 4.096 Mbits/s SGn = 11, 8.192 Mbits/s
	6	H-Bus Group H Rate Select, LSB.		
SGg	5	H-Bus Group G Rate Select, MSB.	Programs streams 24—27.	
	4	H-Bus Group G Rate Select, LSB.		
SGf	3	H-Bus Group F Rate Select, MSB.	Programs streams 20—23.	
	2	H-Bus Group F Rate Select, LSB.		
SGe	1	H-Bus Group E Rate Select, MSB.	Programs streams 16—19.	
	0	H-Bus Group E Rate Select, LSB.		

A quick summary:

The CAMs and the pipeline register files operate as connection memories. The key CAM operation is based on 11 bits of stream and time slot plus 1 bit of read/write in the CAM locations compared against the state counter which tracks the current stream and time slots (Section 2.2.5 State Counter Operation). Each H-bus CAM is looking for matches on 16 of the 32 H-bus streams, and the local CAM is looking for a match on 16 local inputs and 16 local outputs per time slot.

Thirteen bits are required to cover the 5120 possible time slots, but the MSB, LSB combination is used to determine which H-bus CAM is accessed: even H-bus (0, 0), odd H-bus (0, 1). The local H-bus is accessed by selecting the upper 2 MSBs, both equal to 1. The CAM address can be thought of as following this format:

CAM Select Field	Time-Slot Field	Stream Field
2 bits	7 bits	4 bits

This format is rate independent. The CAM select field is part of the address mode register (AMR) for CAM commands (Section 2.1.3 Address Mode Register and Section 2.3.2 CAM Operation and Commands). Programming examples for setting up connections can be found in Section 3.3 Basic Connections.

2 Architecture and Functional Description (continued)

2.4 Substrate Switching for the Ambassador Family

2.4.1 Description, Operation, and Application

This section describes the means of implementing sub-rate telephony switching by leveraging the existing pipelined multistream CAM architecture. In addition, there are implications for extending H.100/H.110 to incorporate sub-rate switching without violating the existing timing or definitions. A practical example of a system which requires sub-rate switching is described in 2.4.7 Example of a Practical Application on page 43.

2.4.2 Definitions

Sub-rate refers to switching fractional portions of the data found in traditional TDM streams. Sub-rate does not refer to changes in the bit rate, i.e., when the bit rate changes, the total number of time slots per second changes, but each time slot still contains data which is propagated at the same data rate, namely 64 kbits/s. Sub-rate refers to data propagated at rates less than 64 kbits/s.

The data byte for a given time slot can be thought of as two nibbles, and if each of these nibbles represents a distinct voice or signal, then it would be correct to say that the nibbles are operating at 32 kbits/s (= 4 bits/frame x 8K frames/second), and that the theoretical channel capacity of the TDM stream has increased by a factor of two. Likewise, if the data byte is broken into four distinct dibits, then the rate is 16 kbits/s, and the capacity of the stream has increased by a factor of 4. Finally, in the extreme case, a data byte is treated as 8 bits, each of which has a rate of 8 kbits/s, which means that the stream capacity has increased by a factor of 8.

The above definition also leads to the concept of density. If only one piece of sub-rate data is used in a byte, then it can be referred to as **sparsely packed**. Likewise, if all positions of the data byte contain sub-rate data, the byte is **fully packed** or **densely packed**. Packing thus refers to the utilization of the sub-rate data positions in a byte.

Sub-rate switching refers to the transfer of sub-rate data pieces (nibbles, dibits, or bits), just as **switching** implies the transfer of data bytes. True sub-rate switching is the ability to move sub-rate data from any sub-rate position to any other sub-rate position. Obviously, there are restrictions which must be employed to make sub-rate switching practical. This is discussed in the next section.

2.4.3 Sub-rate Switching on H.100/H.110

H.100/H.110 are based on byte-oriented TDM data streams. H.100/H.110 have well-defined electrical parameters to describe when an output driver gains access to the bus and when it releases the bus (at the end of the byte). There are no provisions in either H.100 or H.110 to extend these electrical parameters to include driving the bus on an individual bit basis, and due to the propagation characteristics of the bus wires on H.100, it is not desirable to attempt to drive the bus this way.

Since H.100/H.110 data must always be switched as whole bytes on H.100/H.110, sub-rate data will have to be packed into the bytes prior to switching. The data bytes are not necessarily constrained to using fully packed bytes. Any portion of a byte may be used.

An example is shown in Figure 12.

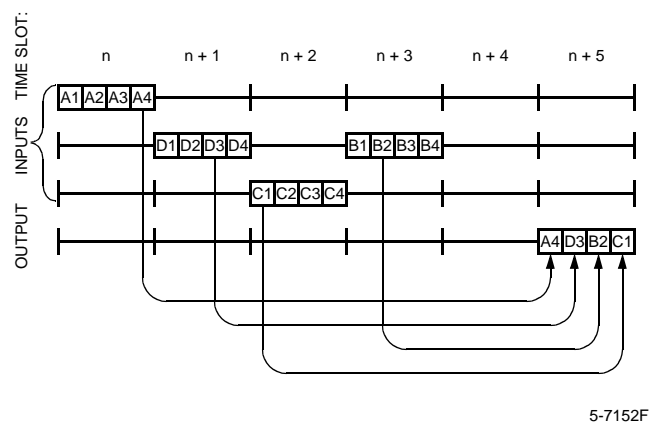

Progressive assembly of the output data in a location in the H-bus data buffer as each input sub-rate data piece is received:

TIME SLOT n:	A4	X	X	X
TIME SLOT n + 1:	A4	D3	X	X
TIME SLOT n + 2:	A4	D3	X	C1
TIME SLOT n + 3:	A4	D3	B2	C1

THE FULLY ASSEMBLED BYTE WILL BE READ FROM THE DATA BUFFER FOR OUTPUT DURING TIME SLOT n + 5.

Figure 12. Sub-rate Switching Example

2 Architecture and Functional Description (continued)

2.4 Substrate Switching for the Ambassador Family (continued)

2.4.4 Using the Existing Architecture

It is possible to create a substrate switching structure utilizing a variant of the existing pipelined multistream CAM architecture. Since access to the H-bus continues to require bytes, the CAM size does not change. CAMs will continue to track stream and time-slot addresses. The changes to the architecture are all related to the data storage as it comes in from the bus. The most fundamental change is that selected substrate data pieces can be individually stored, not necessarily the entire incoming data byte. For example, the uppermost dibit can be stored and the other dibits ignored. Thus, with several incoming data bytes contributing substrate pieces, a new data byte, composed of one or more substrate pieces from different sources, can be constructed. (See Figure 12.)

Structurally, the change in the data buffers is from the existing 512 x 8 (T8102, T8105 only) register file (or 256 x 8 for the T8100A) to eight 512 x 1 (T8102, T8105 only) register files (or eight 256 x 1 register files). Each of these columns has a separate write enable. To support this change, the tag register associated with each CAM must be extended by 7 bits to identify the source of the substrate data (i.e., identify which piece of the

incoming byte is to be used) and the destination of the substrate data (i.e., identify which bits of the data location will be written into). Table 45 Permitted Tag Extensions below lists the permitted entries in the extension of the tag. While the writes into the data buffers are fine grained, as small as a single bit write, the reads must be as a whole byte to maintain the byte-orientation of the H.100/H.110 bus as described previously.

Table 45. Permitted Tag Extensions

Tag Extensions	Bit						
	6	5	4	3	2	1	0
	MSB	Source Field			Destination Field		
Byte (1 entry only)	0	00x			00x		
Nibble (4 combinations)	0	010—011			010—011		
Dibit (16 combinations)	0	100—111			100—111		
Bit (64 combinations)	1	000—111			000—111		

The substrate switching is optional; a bit in the identification register will permit the substrate operation. The bit defaults to zero, so that the tag extension is ignored and the data buffers are treated as 512 x 8 (T8102, T8105 only). If set, the columns are individually addressed by the tag extensions.

2 Architecture and Functional Description (continued)

2.4 Subrate Switching for the *Ambassador* Family (continued)

2.4.4 Using the Existing Architecture (continued)

Figure 13 illustrates the changes to the architecture of the *Ambassador* family.

The subrate enable bit (GMODE bit 5) is intended as a static control; that is, if subrate is going to be performed, this bit must be set before attempting any CAM operations. The internal circuit monitors the state of this bit, and performs different command protocols depending on its value. For a T8100A device with subrate disabled, the protocol is identical to that of a T8100; that is, the SCT register is not used, writes to it and reads from it are disabled, and the internal state machine expects (and will only handle) three IDR reads for an RDC command. For a T8100A device with subrate enabled, writes to and reads from SCT are enabled, and the internal state machine expects (and will only handle) four IDR reads for an RDC command.

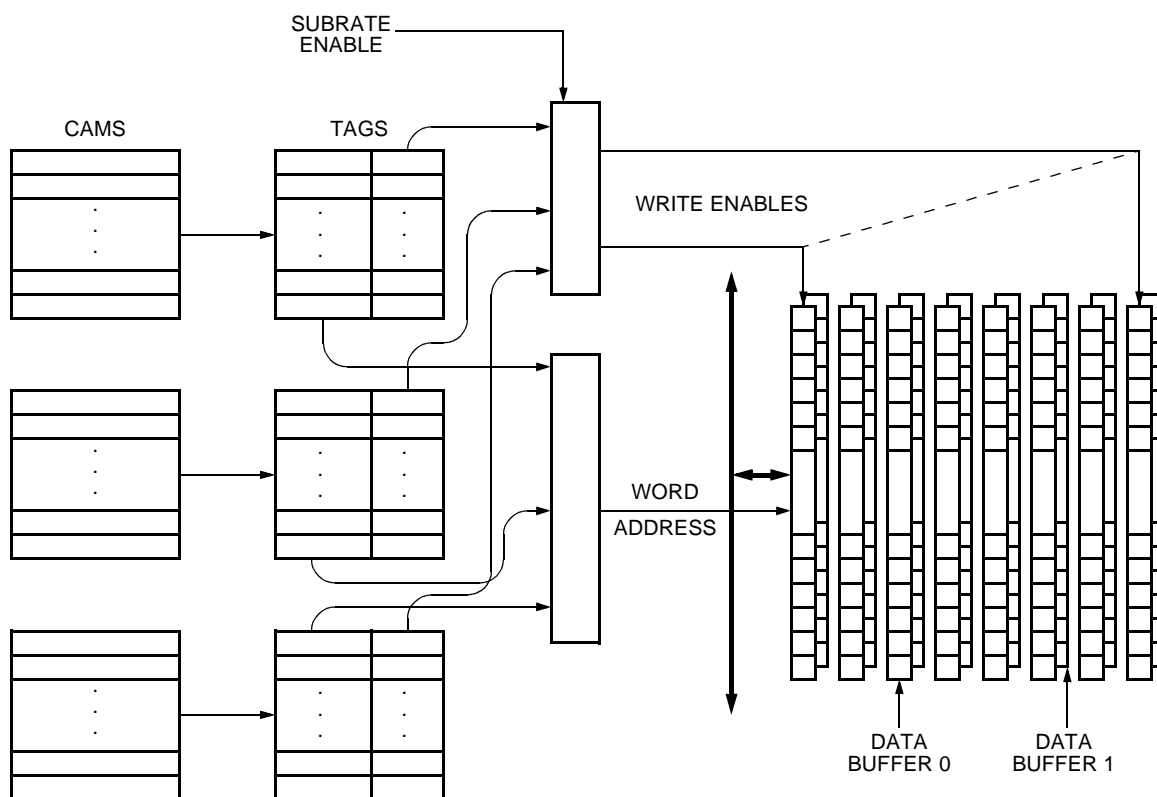

5-7151F

Figure 13. Modifications for Subrate Switching

2 Architecture and Functional Description (continued)

2.4 Substrate Switching for the Ambassador Family (continued)

2.4.5 Limitations

While the structure described above is a relatively simple extension to the existing architecture, it also imposes one limitation which must be overcome by application. To prevent changes in the CAM size and operation, the assumption is that the data is utilized only once after the stream plus time slot has been recognized. (This prevents the multiple hit/multiple access scenario, in which a byte which contains multiple sub-rate pieces will not have to be accessed several times.) To gain access to all sub-rate pieces present in one incoming byte, that same byte must be broadcast on multiple stream plus time slots. In this case, each sub-rate piece can be switched to the appropriate output. The ideal scenario is to make use of local switching (either the local TSI or the local CAM) to provide a loopback for broadcasting the byte in question. Specifically, the byte is switched to multiple time slots on a local output. (The packed byte is coming either from a local input or from the H.100 bus.) The local output is physically tied to a free local input, and, in turn, the multiple time slots are substrate switched to the appropriate outputs (on the H.100 bus, for example). This introduces an additional delay of one frame, but allows for efficient utilization of the H.100 bus as a substrate switching fabric (see Figure 14).

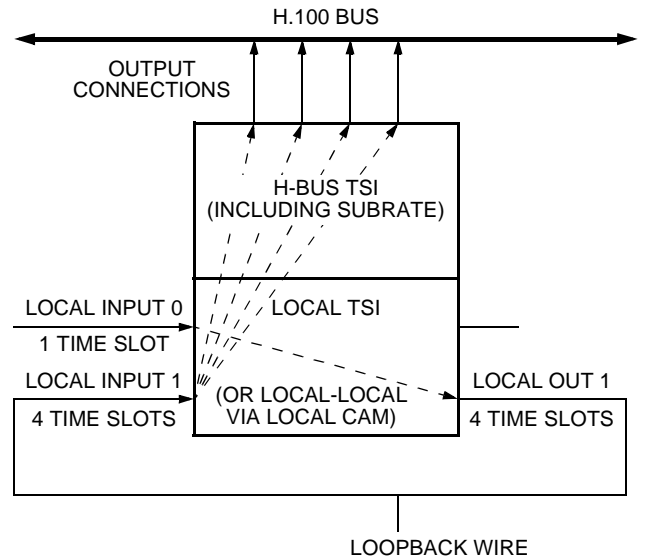

5-7148F

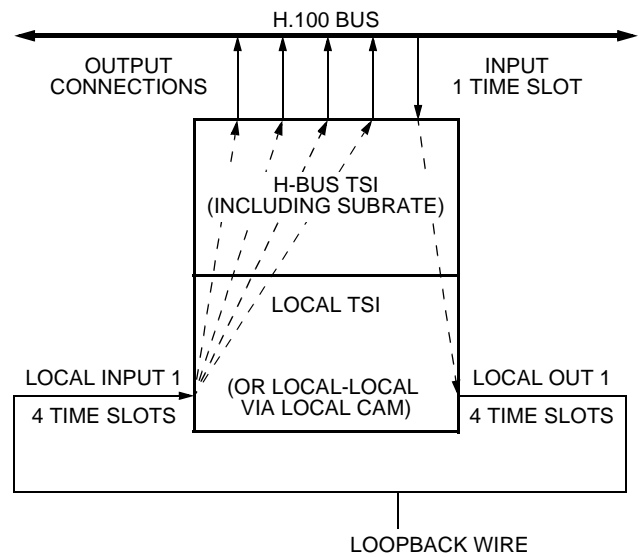

5-7149F

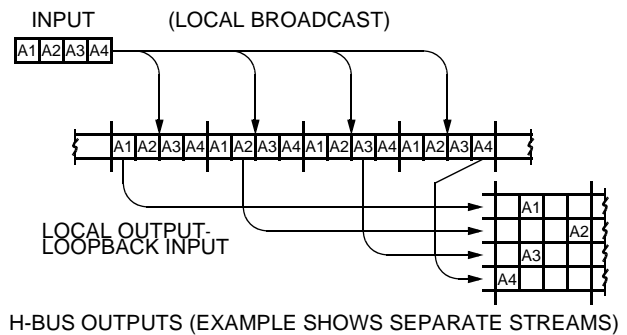

5-7149F

Figure 14. Unpacking Example Using Local Loopback

2 Architecture and Functional Description (continued)

2.4 Subrate Switching for the *Ambassador* Family (continued)

2.4.6 Minimum vs. Constant Delay

The same issues involved with **virtual framing** exist in subrate switching as in traditional switching. The scenario is one in which the subrate data comes from several sources which cross a frame boundary. The selection of the framing bit remains identical to the byte scenario. To maintain the virtual frame, some subrate data must have the frame bit (FME) set, and some must have them cleared. Operationally, there is no difference. Since the inputs and outputs are identified by stream and time-slot addresses, charts from Appendix B of this data sheet can be used to determine the FME bit setting. Figure 15 below shows an example of virtual framing for subrate connections.

FME settings for individual subrate pieces, in order to maintain virtual frame integrity across the true frame boundary, are based on the description in Appendix B (all streams 8 Mbits/s).

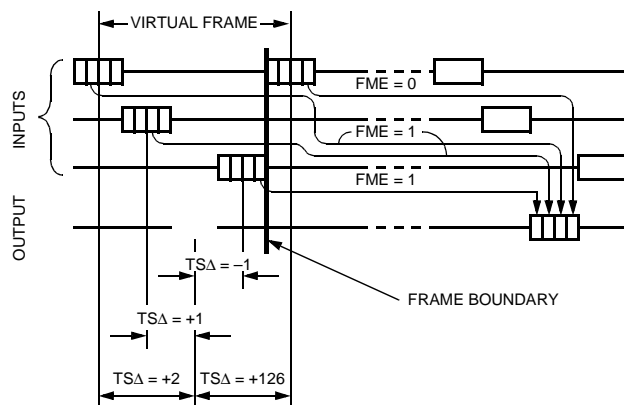

5-7147F

Figure 15. Constant Delay/Minimum Delay Example

2.4.7 Example of a Practical Application

Three 16 kbits/s GSM voice channels are presented with either 1 or 2 bits of HDLC/LAPD. The user wishes to strip out the HDLC/LAPD information and pass through the voice channels with minimum latency.

Specific requirements are listed below:

1. The ability to extract 1 or 2 bits from any time slot presented. The time slots are presented via T1/E1 or from the H.100 bus. The extracted bits will be treated as an HDLC/LAPD channel and must be presented separately to a host CPU.
2. The ability to inject a 1 or 2 bit stream into any time slot.
3. The bit positions to be extracted/injected must be programmable. In the case of injection, the injected bits will overwrite the value of the bits previously occupying those positions.
4. The ability to switch full time slots presented to it while performing injection/extraction.

The terms **injection** and **extraction** are synonymous with **packing** and **unpacking**.

Clearly, the applications for subrate switching are numerous. In the 16 kbits/s GSM world alone, the H.100 bus could be thought of as a 16,384 subrate time-slot bus. Since the subrate is programmable on a time slot by time-slot basis, mixed subrates are possible as well, even within a single time slot.

2.5 Clocking Section

The clocking section performs several functions which are detailed in the following paragraphs. In general, when the devices are in bus master mode, there will be one or more companion devices which provide the basic clock extraction and jitter attenuation from a source (such as a trunk). As a slave, the devices can work independently of, or in conjunction with, external resources. Examples of different operating modes are provided in Appendix A. Refer to Figure 16 for a block diagram of the devices clocking section.

When the devices are used as bus masters, an input clock of a tolerance of ± 32 ppm is required. This can come from several sources. For example:

- ± 32 ppm crystal tolerance is the suggested value if either the DPLL is used or fallback to the oscillator is enabled while mastering the bus. Otherwise, a crystal with a lesser tolerance can be used.
- If a crystal is not used, a 16.384 MHz (± 32 ppm tolerance or less) signal must be provided to the XTALIN pin, and XTALOUT should be left unconnected.
- The L_REF inputs can also be used and must conform to ± 32 ppm in a bus master situation.

2 Architecture and Functional Description (continued)

2.5 Clocking Section (continued)

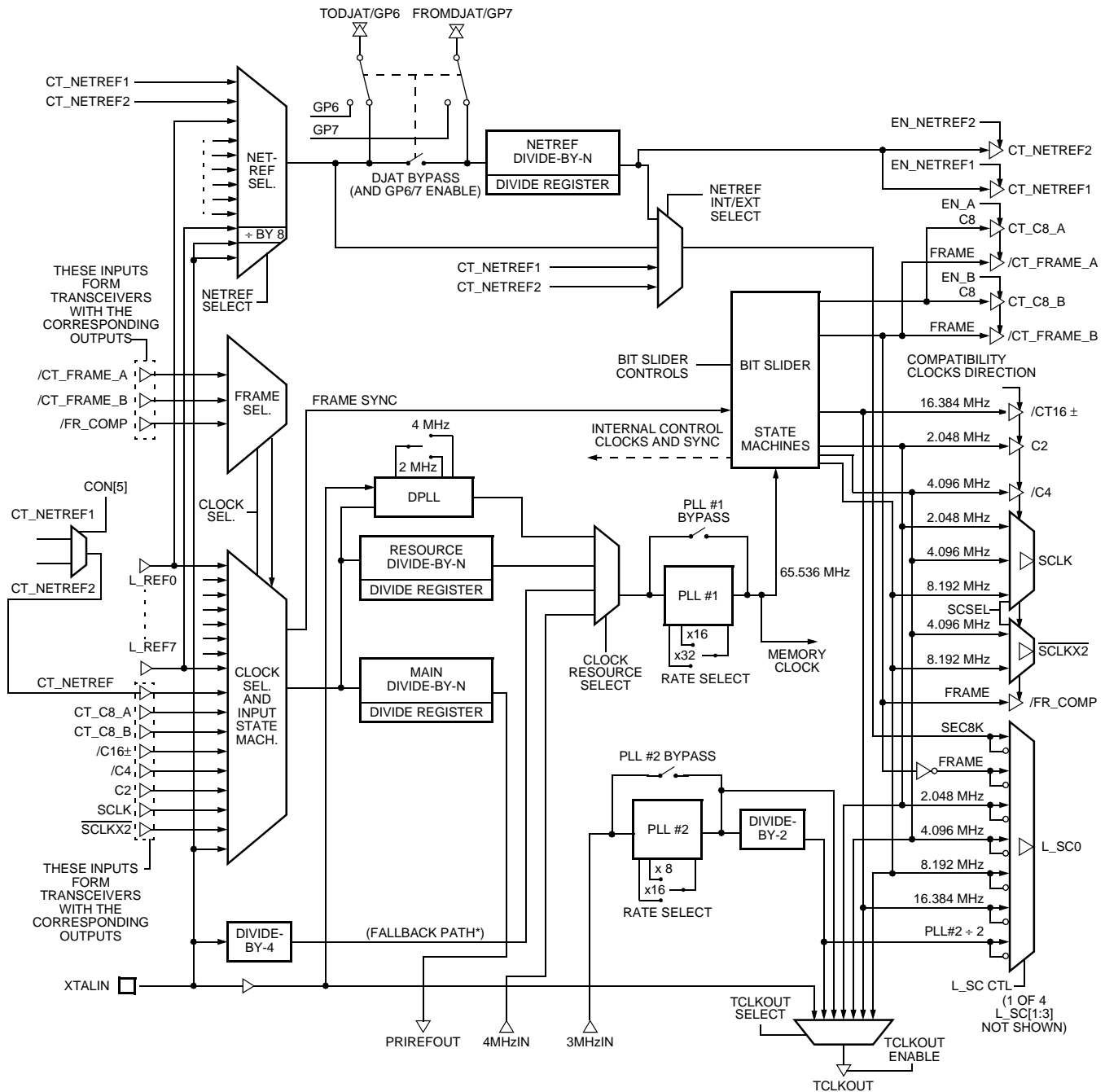

5-6111dF

* The path for XTALIN divide-by-4 is for fallback only.

Figure 16. Clocking Section

2 Architecture and Functional Description (continued)

2.5 Clocking Section (continued)

2.5.1 Clock and NETREF Selection

Three selectors provide device input clocking. The clock selector and frame selector operate from a common set of selection options in register CKM (see Section 2.5.8 Clock Control Register Definitions for register details), where FRAMEA is selected along with clock C8A and FRAMEB is selected along with clock C8B. Typically, one of the local references (L_REF[0:7]) will be selected when the devices are operating as masters, though the local oscillator is also available. As a slave, the most common selections will be one of the bus types. Each bus type has a state machine associated with it for determining the frame sync. All clock inputs are sampled to check for proper switching. If the expected clock edge does not occur, and there is no switching on CT_NETREF for 125 μ s, a bit corresponding to the errant clock is set in the CLKERR register (see Section 2.7 Error Registers for more details). NETREF can be created from one of the local references or from the oscillator independent of the clock generation.

2.5.2 Dividers and Rate Multipliers

The clock and NETREF selections are routed to dividers*. In the case of NETREF, the divider is usually used to reduce a bit rate clock to 8 kHz, so the most common divisors will be 1, 193 (1.544 MHz/8 kHz), and 256 (2.048 MHz/8 kHz), although a full range of values (from 1—256) is possible. For the clock selector, the signal will most often be routed through the main divider when the devices are operating as masters or through the resource divider when operating as slaves. Both the main and resource dividers are fully programmable.

The ultimate destination for the main or resource divider is intended to be PLL #1. PLL #1 accepts either a 2.048 MHz or 4.096 MHz input and will rate multiply up to 65.536 MHz. The divisor of the main or resource dividers is chosen in conjunction with the rate select of the PLL, i.e., a divisor which generates a 4.096 MHz output and a rate selection of x16, or a divisor which generates a 2.048 MHz output and a rate selection of x32. This provides a great deal of flexibility in adapting to a variety of (external) clock adapters and jitter attenuators while acting as a master, as well as slaving to several bus types.

A digital PLL that can rate multiply to either 2.048 MHz or 4.096 MHz from an 8 kHz source in the absence of an external clock adapter is also provided. PLL #1 can be bypassed for diagnostic purposes or if an external clock adapter is used that provides a high-speed output (65.536 MHz). The input to the DPLL is an 8 kHz signal.

A second rate multiplier is provided for supporting T1 applications. It is optimized around either a 1.544 MHz or 3.088 MHz input rate which multiplies to 24.704 MHz and is then divided down to provide 50% duty cycle clocks of 12.352 MHz, though the direct 24.704 MHz is available as well. A bypass is provided so that an external clock can be buffered through the TCLK output. The internal oscillator or the various outputs derived from PLL #1 can also be selected for the TCLK output.

2.5.3 State Machines

The purpose of the state machines is to generate internal control signals for the remainder of the circuitry and to provide all bus clocks when operating as a master. The state machines operate from the 65.536 MHz clock generated by PLL #1, and they are time referenced to the frame sync derived from the selected clock and frame inputs. As a master, the time sync is based on the device's own generated frame.

The dominant internal control signals are a noninverted 32.768 MHz clock, an inverted 16.384 MHz state clock, and a noninverted 122 ns wide sync pulse centered around the beginning of a frame. The memories are synchronized to the 65.536 MHz clock.

2.5.4 Frame Sync

Frame sync is not generated in absence of an external frame clock. The state machines will randomly synchronize to the 65.536 MHz clock.

2.5.5 Bit Sliding (Frame Locking)

The devices generate frame signals based on the incoming clock and frame references and device generated clock signals. When slaving, it is sometimes necessary to align the edges of this generated frame signal to the incoming frame reference.

* If the A clocks have been selected as the clock source through the CKM register (described in Section 2.5.8 Clock Control Register Definitions), then the CT_C8A is the signal sent to the main and resource dividers; likewise, selecting B clocks results in sending CT_C8B; the *MVIP* selection sends /C4; the H-*MVIP* selection sends the recovered /C16 (derived from differential inputs); selecting SC2 sends SCLKX2; and SC4/8 sends SCLK to the dividers.

2 Architecture and Functional Description (continued)

2.5 Clocking Section (continued)

2.5.5 Bit Sliding (Frame Locking) (continued)

The devices generate frame signals based on the incoming clock and frame references and device generated clock signals. When slaving, it is sometimes necessary to align the edges of this generated frame signal to the incoming frame reference.

To accomplish this, the devices will compare the referenced frames with the current state of its clock state machine, and if the difference exceeds one 65.536 MHz clock cycle, the entire stream will have a fraction of a bit time removed from each frame; this is referred to as bit sliding. The process will repeat until the measurements fall within one clock cycle. The actual bit sliding will take place by reducing the generated frame by one 65.536 MHz clock cycle at the beginning of the frame. This means that the frame edges will phase-align at the rate of approximately 15.26 ns per frame. The maximum phase difference is slightly less than one frame or 124.985 μ s. Thus, it will require approximately 8000 frames, or 1 second, to phase-align the frame. This is mean time interval error (MTIE) complaint.

The alternatives to bit sliding are snap alignment and no alignment. Snap alignment refers to an instantaneous phase alignment, i.e., a reset at the frame boundary. This mode is common to other devices. If no alignment is chosen, the device's generated frame is frequency-locked to the incoming frame sync, but not phase-aligned.

2.5.6 MTIE

MTIE is defined in AT&T technical reference TR62411. MTIE is a characteristic of wander. Wander is defined as clock phase deviations that are less than 10 Hz in frequency. MTIE defines the amplitude of the wander. The maximum amplitude, in the DS1/T1 world, is 1 μ s (about 1.5 bit times). This is measured by sampling the delta of actual clock edges from the ideal positions over 2048 bit times (1.326 ms). The secondary requirement is that no two edges may deviate by more than 81 ns (1/8 bit time).

Apply this to the essentially E1-like timing in the H.100/110/MVIP/SC-Bus worlds:

1.5 bit times is about 750 ns
2048 samples is 1 ms
1/8 bit time is about 61 ns

2.5.6.1 MTIE Compliance

T810X is MTIE compliant; however, the user **must** pay attention to the system application. The T810X requires Stratum 4e clocks, which are already sup-

posed to meet 32 ppm stability and 1 μ s MTIE compliance, and will in turn remain Stratum 4e on the outbound side. External trunks, T1 or E1, must be run through framers (and a jitter attenuator, if not present in the framer) to help ensure the input requirement. Given this, the T810X is compliant in that it will not introduce phase hits into the system which are uncontrolled, neither as high frequency (jitter) nor as low frequency (wander).

For a given clock, the T810X should respond in such a way that the wander does not perturb the outbound clocks greater than 61 ns per 2.048 MHz cycle, or more than a total of 750 ns over any 1 ms measuring period. These numbers are aided by the analog PLL. Any phase hit is smoothed to 800 ps/65 MHz clock cycle which is 25.6 ns/2.048 MHz clock cycle. Thus, the 61 ns/bit time is met. The 750 ns number is constrained by the input requirement. Given that the inbound side will be no greater than 750 ns over the 1 ms sampling period, the T810X's outbound clocks will show a maximum deviation in the 1 ms period on the order of 315 ns. In truth, framers, with accurate crystals, tend to absorb much of the wander in slip buffers, so this number should be very small.

While not a specific requirement of Stratum 4e, all T810X products do provide holdover capability. The T810X will respond, in a controlled fashion, to a change of clock source. Again, the measurement method for this uses the MTIE specification. The worst-case response will be a 25.6 ns shift of clock edge per 0.048 MHz clock cycle less than the MTIE specification.

2.5.6.2 Relationship of the Bit Slider to MTIE

Strictly speaking, the bit slider is not related to MTIE in that MTIE makes no provision for frame wander. The bit slider itself however, will not introduce more than 15.26 ns/frame of additional shift, when enabled. The slider does not affect the PLL or the clocks on a constant basis, it simply walks the generated frame into alignment with the received frame. Thus, the stability of the clock edges remains constant in the long term, but individual edges may deviate by an additional amount, making the edge-to-edge absolute maximum 25.6 ns + 15.3 ns = 40.9 ns.

The critical item to relating MTIE with the bit slider is that the bit slider won't make the T810X fail MTIE.

2.5.6.3 Using the Bit Slider

The bit slider is primarily intended for maintaining the local side of an application. Specifically, some DSPs have limited synchronizing ability and once they are phase-aligned with the frame, a loss of frame sync can be disruptive. The bit slider allows a change of source to gracefully realign to a new frame without tripping up the synchronization. There is limited benefit on the H.100 side—snap mode is equivalent to slide in terms of A/B clock fail-over, but the local side is much different.

2 Architecture and Functional Description (continued)

2.5 Clocking Section (continued)

2.5.6 MTIE (continued)

2.5.6.3 Using the Bit Slider (continued)

A secondary benefit may come about in T8100A/02/05 applications which use sliding between frames on local reference inputs. In this case, a board that is mastering an H.100/H.110 system, can pull an entire system slowly into frame alignment with external trunks, instead of just frequency locking to external trunks.

2.5.7 Clock Fallback

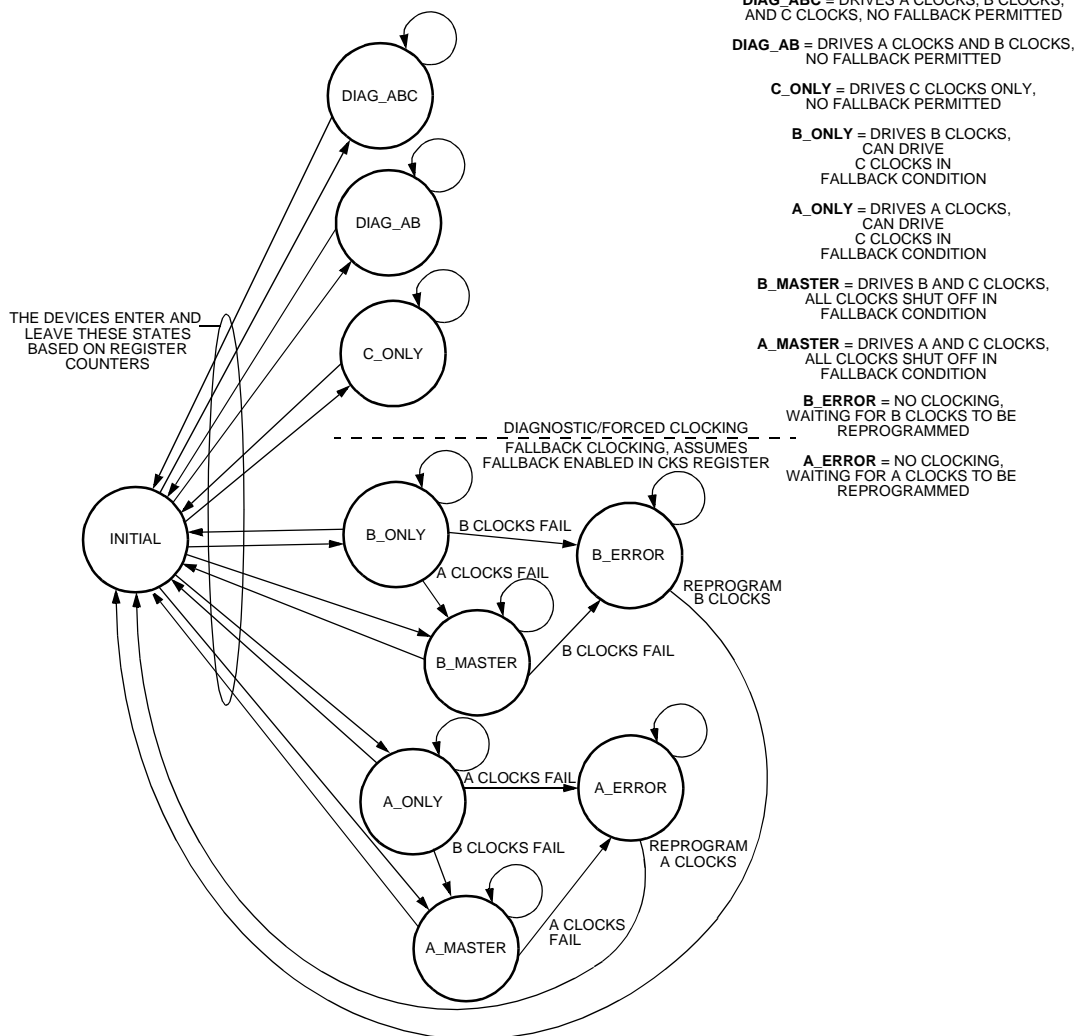

5-6112F

Figure 17. A, B, and C Clock Fallback State Diagram

2 Architecture and Functional Description (continued)

2.5 Clocking Section (continued)

2.5.7 Clock Fallback (continued)

The following conditions must be met before fallback is initiated:

- Fallback must be enabled in register CKS.
- Failure of one or more of the clocks selected through the CKSEL bits in the CKM register.
- All clocks which comprise the selection from CKSEL must be unmasked in register CKW (see Section 2.7 Error Registers).

The devices contain a fallback register which enables a backup set of controls for the clock resources during a clock failure. In addition, a fallback state machine provides some basic decision-making for controlling some of the clock outputs when the feature is enabled. While slaving to the bus, the primary course of action in fallback is the swap between the A clocks and B clocks as the primary synchronization sources. A slave may become a master only under software control; i.e., there is no automatic promotion mechanism. As a master, the devices detect their own failures and remove their clocks from the bus. If a failure is detected on the other main set (e.g., B master detects failures on the A master), then the devices can assume the role of the primary synchronization source by driving all compatibility clocks (H-MVIP and SC-Bus). Clock failures are flagged through the CLKERR1, CLKERR2, and CLKERR3 registers (Section 2.7 Error Registers). Additional fallback details are discussed in relationship to the clock registers in the next section. The divide-by-4 block for XTALIN, shown in Figure 16, is used only for fallback. See Figure 17 for a diagram of the basic state machine which controls the A, B, and C (compatibility) clocks. Figure 18 shows a diagram for programming the device's registers when a fallback condition is detected.

Figure 18 shows the steps required to program the registers when a fallback condition is detected.

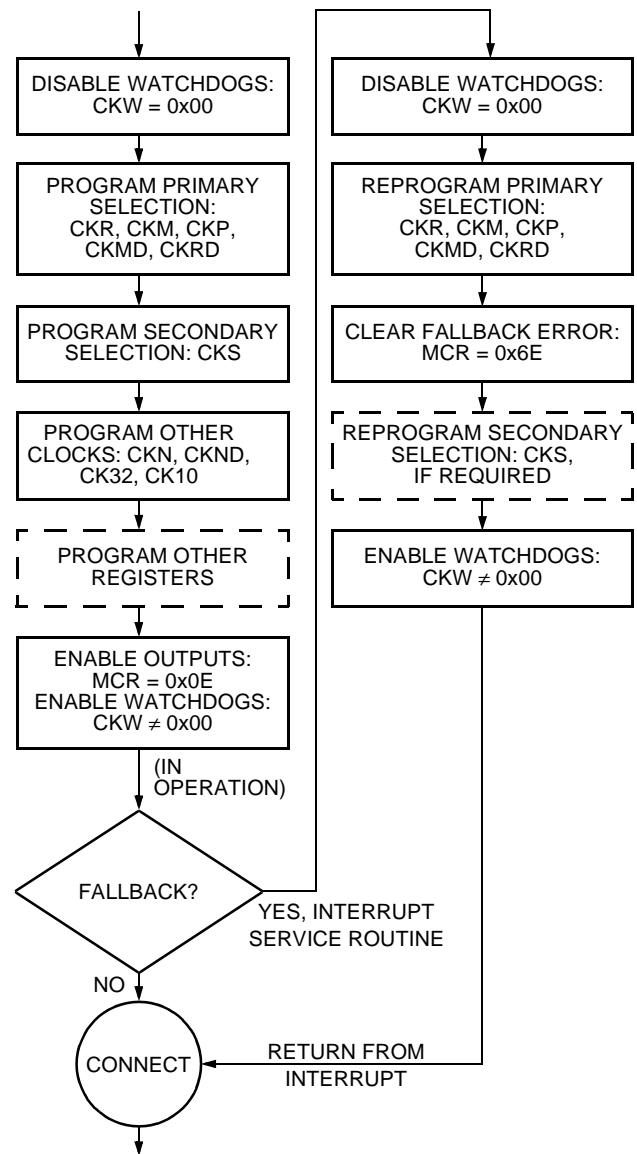

Restarting the clocks after a fallback condition:

1. Clear the CKW register to prevent any more clock errors.
2. Clear CKM bit 5 (CCD) to be a slave.
3. Clear CKP bits 2 and 3 to prevent sourcing a compatibility clock.
4. Set CKM bit 5 (CCD) to be a master again.
5. Set CKP bits 2 and 3 to drive the appropriate A or B clocks.
6. Clear SYSERR and CLKERR bits via MCR.
7. Set the appropriate bits in CKW to enable watchdogs.

5-7250aF

Figure 18. Programming Sequence

2 Architecture and Functional Description (continued)

2.5 Clocking Section (continued)

2.5.8 Clock Control Register Definitions

Table 46. CKM: Clocks, Main Clock Selection, 0x00

The first register, 0x00, is the clock main (CKM) register. There are ten registers to control the various aspects of clocking.

Reg	R/W	Bit 7	Bit 6	Bit 5	Bit 4	Bit 3	Bit 2	Bit 1	Bit 0
CKM	—	PAE	PAS	CCD	CKI	CKSEL			

Symbol	Bit	Description
PAE	7	Phase Alignment Enable. PAE = 0, Retains frequency lock without phase alignment. PAE = 1, Enables phase alignment.
PAS	6	Phase Alignment. PAS = 0, Phase alignment, snap. PAS = 1, Phase alignment, slide.
CCD	5	The CCD bit is the compatibility clock direction. This controls the I/O for the compatibility clocks /C16+/-, /C4, C2, SCLK, SCLKX2, and /FR_COMP (compatibility frame). The user can think of the CCD bit (in some respects) as a master/slave select for the compatibility clocks, though other registers require proper setup to establish true master or slave operation. The devices will assume control of this bit during a fallback if the previously designated compatibility clock master fails. CCD = 0, Slave, monitors compatibility signals. CCD = 1, Master, drives compatibility signals. Note: If bit 4 of the programmable clocks register, CKP, is low, then the state machines of the A clock and B clock will assume this is an MC-1 system and interpret the clocks as /C4(L/R) and FRAME(L/R). If this bit is high, then it interprets the clocks as C8(A/B) and FRAME(A/B).
CKI	4	CKI is used to invert the output of the clock selector, i.e., the signal which feeds the main divider, resource divider, and DPLL: CKI = 0, Normal. CKI = 1, Invert.
CKSEL	3—0	The decode for the clock selector (CKSEL) is illustrated below. These selections determine which input state machine is utilized*: CKSEL = 0000, Internal oscillator. CKSEL = 0001, CT_NETREF1 or CT_NETREF2 (CON register bit 5 selects: if 0 then CT_NETREF1 is selected, if 1 CT_NETREF2). CKSEL = 0010, A clocks (C8A & FRAMEA); ECTF or MC-1. CKSEL = 0011, B clocks (C8B & FRAMEB); ECTF or MC-1. CKSEL = 0100, MVIP is selected, /C4 is selected as the clock reference for PLL #1. CKSEL = 0101, H-MVIP is selected, /C16 is selected as the clock reference for PLL #1. CKSEL = 0110, SC-Bus, 2 MHz. SCLKX2 is selected as the clock reference for PLL #1. CKSEL = 0111, SC-Bus, 4 MHz or 8 MHz. SCLK is selected as the clock reference for PLL #1. CKSEL = 1000—1111 Selects local references 0—7. When bit 4 of the CON register is set, these bits select pairs of synchronized inputs.

* Selecting A clocks synchronizes the devices to CT_C8A and /CT_FRAMEA; selecting B clocks synchronizes the devices to CT_C8B and /CT_FRAMEB; MVIP uses /C4, C2, and /FR_COMP; H-MVIP uses /C16+/-, /C4, C2, and /FR_COMP; SC2 uses SCLKX2 and /FR_COMP; SC4/8 requires SCLK, SCLKX2, and /FR_COMP. MC-1 fallback clocks use the same inputs and state machine as the A clocks and B clocks with an inversion selected from register CKP. A pictorial view of the various clocks is shown in Section 4.8.1 Clock Alignment.

2 Architecture and Functional Description (continued)

2.5 Clocking Section (continued)

2.5.8 Clock Control Register Definitions (continued)

Table 47. CKN: Clocks, NETREF Selections, 0x01

Clock register 0x01 is CKN, the CT_NETREF select register. This register selects features for generating and routing the CT_NETREF signal.

Reg	R/W	Bit 7	Bit 6	Bit 5	Bit 4	Bit 3	Bit 2	Bit 1	Bit 0
CKN	—	NR12EN		NDB	NRI	NRSEL			

Symbol	Bit	Description
NR12EN	7—6	NR12EN enables the selection between NETREF1 and NETREF2. NR12EN = 00, The value of NRSEL[3:0] of CKN determines what is routed to the L_SCs. NR12EN = 01, Enable NETREF2 for output, route NETREF1 input to the L_SCs. NR12EN = 10, Enable NETREF1 for output, route NETREF2 input to the L_SCs. NR12EN = 11, Enable both NETREF[1:2] for output, route output of NETREF divide-by-N to LSCs.
NDB	5	NDB = 0, TODJAT pin comes from NETREF selector, and FROMDJAT pin goes to NETREF divider. NDB = 1, NETREF selector goes directly to NETREF divider.
NRI	4	NRI inverts the output of the NETREF selector. NRI = 0, Normal. NRI = 1, Invert.
NRSEL	3—0	The NRSEL is similar to CKSEL but with fewer choices: NRSEL = 0000, Internal oscillator divided by 8. NRSEL = 0001, Internal oscillator. NRSEL = 0010, Select NETREF1 as input. NRSEL = 0011, Select NETREF2 as input. NRSEL = 0100—0111, (Reserved.) NRSEL = 1000—1111, Local references 0—7.

2 Architecture and Functional Description (continued)

2.5 Clocking Section (continued)

2.5.8 Clock Control Register Definitions (continued)

Table 48. CKP: Clocks, Programmable Outputs, 0x02

Clock register 0x02, CKP, is the programmed clocks register. It is used for programming the CT_C8 clocks and enabling its outputs. It is also used to program the TCLK selector. CT_C8 may be operated as either 8 MHz (normal or inverted) or 4 MHz (normal or inverted). C8IS is used to invert the synchronization on C8A and C8B when they are selected for input. The C8 and FRAME signals, which are also generated internally, are routed to both the CT_C8A and /CT_FRAMEA and to the CT_C8B and /CT_FRAMEB. The CAE and CBE pins enable these output pairs independently. The C8C4 pin selects 8.192 MHz or 4.096 MHz signals to be output on C8A and C8B (for supporting for either ECTF or MC-1 applications). CFW selects the output width of the compatibility frame. The register format is as follows.

Reg	R/W	Bit 7	Bit 6	Bit 5	Bit 4	Bit 3	Bit 2	Bit 1	Bit 0
CKP	—	PTS			C8IS	CAE	CBE	C8C4	CFW

Symbol	Bit	Description
PTS	7—5	The three PTS bits select the output sent to the TCLK. This output is intended to be used for driving framers. PTS = 000, 3-state. PTS = 001, Oscillator, buffered output. PTS = 010, PLL #2, direct output. PTS = 011, PLL #2, output divided by 2. PTS = 100, 2.048 MHz from state machines. PTS = 101, 4.096 MHz from state machines. PTS = 110, 8.192 MHz from state machines. PTS = 111, 16.384 MHz from state machines.
C8IS	4	C8IS = 0, MC-1 (A and B clocks inputs interpreted as /C4 with /FRAME). C8IS = 1, ECTF (A and B clocks inputs interpreted as C8 with /FRAME).
CAE	3	CAE = 0, Disable CT_C8A & /CT_FRAMEA outputs. CAE = 1, Enable CT_C8A & /CT_FRAMEA outputs. (The devices will automatically disable these on an A clock failure.)
CBE	2	CBE = 0, Disable CT_C8B & /CT_FRAMEB outputs. CBE = 1, Enable CT_C8B & /CT_FRAMEB outputs. (The devices will automatically disable these on a B clock failure.)
C8C4	1	C8C4 = 0, Inverted 4.096 MHz (MC-1 output mode). C8C4 = 1, Noninverted 8.192 MHz (ECTF output mode).
CFW	0	CFW = 0, Narrow (122 ns) /FR_COMP. CFW = 1, Wide (244 ns) /FR_COMP.

2 Architecture and Functional Description (continued)

2.5 Clocking Section (continued)

2.5.8 Clock Control Register Definitions (continued)

Table 49. CKR: Clocks, Resource Selection, 0x03

Clock register 0x03, CKR, is the clock resources register. It is used for selecting and programming miscellaneous internal resources, the two PLLs, the DPLL, and the clock resource selector. It is also used to program the SCLK/SCLKX2 clock outputs. The register format is as follows:

Reg	R/W	Bit 7	Bit 6	Bit 5	Bit 4	Bit 3	Bit 2	Bit 1	Bit 0
CKR	—	CRS		P1B	P1R	P2B	P2R	SCS	

Symbol	Bit	Description
CRS	7—6	The CRS[7:6] bits are used to select the input to PLL #1. CRS = 00, External input (through the 4MHzIN pin). CRS = 01, Resource divider. CRS = 10, DPLL @ 2.048 MHz. CRS = 11, DPLL @ 4.096 MHz.
P1B	5	P1B and P1R control PLL #1. P1B = 0, Normal PLL #1 operation. P1B = 1, Bypass PLL #1.
P1R	4	P1R = 0, PLL #1 rate multiplier = 16. P1R = 1, PLL #1 rate multiplier = 32.
P2B	3	P2B and P2R control PLL #2. P2B = 0, Normal PLL #2 operation. P2B = 1, Bypass PLL #2.
P2R	2	P2R = 0, PLL #2 rate multiplier = 8. P2R = 1, PLL #2 rate multiplier = 16.
SCS	1—0	The SCS[1:0] bits are used to program the outgoing SC-Bus compatibility signals. SCS = 00, SC-Bus outputs 3-stated. SCS = 01, SCLK @ 2.048 MHz, SCLKX2 @ 4.096 MHz. SCS = 10, SCLK @ 4.096 MHz, SCLKX2 @ 8.192 MHz. SCS = 11, SCLK @ 8.192 MHz, SCLKX2 @ phase shifted 8.192 MHz.

2 Architecture and Functional Description (continued)

2.5 Clocking Section (continued)

2.5.8 Clock Control Register Definitions (continued)

Table 50. CKS: Clocks, Secondary (Fallback) Selection, 0x04

Clock register 0x04 is CKS, the secondary clock selection register. This is also referred to as fallback. When programming the clock registers, writing to CKW and CKS should be programmed last. The register is defined as follows.

Reg	R/W	Bit 7	Bit 6	Bit 5	Bit 4	Bit 3	Bit 2	Bit 1	Bit 0
CKS	—	FRS		FTS		FF	FCSEL		

Symbol	Bit	Description
FRS	7—6	FRS provides an alternate clock resource selection. FRS forces the clock resource selector to choose a new source for PLL #1. FRS = 00, External input (through the 4MHzIN pin). FRS = 01, Resource divider. FRS = 10, DPLL @ 2.048 MHz. FRS = 11, DPLL @ 4.096 MHz. Note: The decode is the same as that of the CRS bits (in the clock resource register, CKR).
FTS	5—4	FTS determines the basic fallback mode (see Section 2.5.8.1 Basic Fallback Mode). FTS = 00, This is automatic fallback to the oscillator divided by 4, thus 4.096 MHz. FTS = 01, This disables fallback. FTS = 10, This is one of the two major fallback selections. FTS = 11, This fallback selection specifically supports standard H.100 and H.110 applications.
FF	3	FF forces the use of the FRS, FTS, and FCSEL. FF is used as a test of the fallback, but can also be used as a software-initiated fallback. FF = 0, Normal operation. FF = 1, Force use of secondary (fallback) resources.
FCSEL	2—0	FCSEL is used to select an alternate synchronization source. The FCSEL choices are a subset of the CKSEL values from the CKM register above. The list is presented below: FCSEL = 000, Internal oscillator divided by 4. FCSEL = 001, NETREF2. FCSEL = 010, A clocks (C8A & FRAMEA); ECTF or MC-1. FCSEL = 011, B clocks (C8B & FRAMEB); ECTF or MC-1. FCSEL = 100, NETREF1. FCSEL = 101—111, Selects local references 1—3.

2 Architecture and Functional Description (continued)

2.5 Clocking Section (continued)

2.5.8 Clock Control Register Definitions (continued)

2.5.8.1 Basic Fallback Mode

Note: The fallback mechanism is sticky in that the device will not fallback again if the clocks which were used for fallback fail.

The four modes are described below.

FTS 00 The resource multiplexer is bypassed, thus selection of this mode of operation assumes that PLL #1 has been set up for a x16 multiply (in CKR). The PLL selection cannot be changed during fallback, so both primary and secondary choices must supply the same frequency into PLL #1. Thus, in the case of FTS = 00, it is assumed that the primary clock selection has been set up for 4.096 MHz.

FTS 01 The secondary selections will be ignored. The clock error registers will continue to report transient and stuck errors (if unmasked by CKW), but will not induce the fallback sequence. There are three reasons to use this: as an aid in initializing the T8100, as a diagnostic tool, or in a software-only fallback system. This last item requires some additional explanation. There is a provision in the ECTF H.100 and H.110 specifications which provide for a piece of hardware to support both hardware and software based fallback. In the software-only selection, the part must still report clock failures. This is accomplished through the CLKERR pin, which provides the interrupt to the host, and CLKERR1, CLKERR2, CLKERR3, and CKW, which provide the details of the failures. An interrupt will thus trigger a software sequence which will reprogram the clocks. In the hardware based fallback, the selection is automatic with the intent of maintaining stable operation until the software can service the device.

FTS 10 The choice to move into fallback is triggered by an error on the main (primary) clock selection, as defined by the lower 4 bits of CKM. The main clock selection will have as few as one signal associated with it (main clock selection = NETREF) or as many as five (main clock selection = H-MVIP, which is /C16+, /C16-, /C4, C2, and /FR_COMP). Thus, a failure on any clock in the main selection will induce fallback. Note that these signals **must** be unmasked, as well. So in the case of NETREF above, the lowest bit of CKW must be set. In the case of H-MVIP, at least bits 3, 4, and 5 must be set in CKW. Any additional CKW bits which are set (but not required) will flag a failure on the CLKERR pin and will be set in the CLKERR registers but will not induce a fallback. Further, if fallback is initiated, the CLKERR and the SYSERR pins will go high. The fallback will occur to the selections made in the CKS register. One additional note: this does not apply to the local reference inputs (selections 1000—1111 in the lower 4 bits of CKM). Since these typically come from framers or HDLC controllers, these devices have their own error reporting systems.

FTS 11 This selection induces fallback on the failure of either the A or B clocks independent of the main clock selection. (A and B must be unmasked in CKW.) Since this is intended for H.100 and H.110, it would be unwise to program the main selection to be anything other than A clocks or B clocks. For H.100, the FTS = 11 selection also enables a state machine which controls the compatibility clocks. If bit 5 has been set in the primary clock programming and is also programmed to drive either the A or B clocks, then a self-detected failure will cause the T8100 to remove its clocks from the H.100 bus, both its main (A or B clock set) and the compatibility clocks. Likewise, if bit 5 was not set in the primary clock programming and if the part is slaving to one set (A or B) and driving the other (B or A, respectively) then a failure detected on the clock it is slaving to will automatically cause the device to drive the compatibility clocks. In this way, an H.100 system with an A and B clock set can maintain the operation of compatibility clocks in addition to maintaining H.100 clocking.

2 Architecture and Functional Description (continued)

2.5 Clocking Section (continued)

2.5.8 Clock Control Register Definitions (continued)

2.5.8.1 Basic Fallback Mode (continued)

Table 51. CK32 and CK10: Clocks, Locals 3, 2, 1, and 0, 0x05 and 0x06

Registers 0x05 and 0x06 set up L_SC0, 1, 2, and 3. The outputs L_SC[3:0] can be used as bit clocks for the local streams or as a secondary NETREF. These are programmed using CK32 and CK10, which are presented below.

Reg	R/W	Bit 7	Bit 6	Bit 5	Bit 4	Bit 3	Bit 2	Bit 1	Bit 0
CK32	—	LSC3				LSC2			
CK10	—	LSC1				LSC0			

Register	Symbol	Bit	Description
CK32	LSC3	7—4	LSCn = 0000, Output low.
CK32	LSC2	3—0	LSCn = 0001, Local frame (positive pulse).
CK10	LSC1	7—4	LSCn = 0010, NETREF (Sec8K).
CK10	LSC0	3—0	LSCn = 0011, PLL #2 ÷ 2.
			LSCn = 0100, 2.048 MHz.
			LSCn = 0101, 4.096 MHz.
			LSCn = 0110, 8.192 MHz.
			LSCn = 0111, 16.384 MHz.
			LSCn = 1000, Output high.
			LSCn = 1001, Local frame, inverted.
			LSCn = 1010, NETREF, inverted (negative pulse).
			LSCn = 1011, PLL #2 ÷ 2, inverted.
			LSCn = 1100, 2.048 MHz, inverted.
LSCn = 1101, 4.096 MHz, inverted.			
LSCn = 1110, 8.192 MHz, inverted.			
LSCn = 1111, 16.384 MHz, inverted.			

2.5.8.2 CKMD, CKND, CKRD: Clocks, Main, NETREF, Resource Dividers, 0x07, 0x08, and 0x09

The remaining clock registers are used to program the three dividers. The main divider is programmed through CKMD; the resource divider, through CKRD; and the NETREF divider, through CKND. The dividers are fully programmable.

- MAIN and RESOURCE dividers (CKMD, CKRD)
 - For BINARY divider values of 1, 2, 4, 8, 16, 32, 64, 128, and 256, output is 50% duty cycle.
 - For divider value of 193, output is **almost** 50% duty cycle (low-level duration is one clock cycle shorter than high-level duration).
 - For **all** other divider values, output is a pulse, whose width is **one full clock period**.

- NETREF dividers (CKND)

- For binary divider values of 1, 2, 4, 8, 16, 32, 64, and 128, output is 50% duty cycle.
- For divider values of 256, 193, plus all other non-binary values, output is a pulse, whose width is **one half of a clock period**, asserted during the second half of the divider clock period.

In general, the register value is the binary equivalent of the divisor-minus-one; e.g., an intended divisor of 193 is reduced by 1 to 192, so the register is loaded with the binary equivalent of 192, which is 0xC0.

- 0x00 => Divide by 1 (bypass divider)
- 0x01 => Divide by 2
- :
- 0xC0 => Divide by 193
- :
- 0xFF => Divide by 256

2 Architecture and Functional Description (continued)

2.5 Clocking Section (continued)

2.5.8 Clock Control Register Definitions (continued)

2.5.8.2 CKMD, CKND, CKRD: Clocks, Main, NETREF, Resource Dividers, 0x07, 0x08, and 0x09 (continued)

The CON register controls various features of the device. It has a bit for enabling/disabling the use of the GPD register and a bit for selecting NETREF_1 or NETREF_2. It also has 3 bits for using the L_REF pairing feature. The last 2 bits are programmed when using the minimum and constant delay settings for data transfers. The description and use of the bit(s) for a particular feature is described in the section which pertains to the feature.

Table 52. CON Register 0x0E

Reg	R/W	Bit 7	Bit 6	Bit 5	Bit 4	Bit 3	Bit 2	Bit 1	Bit 0
CON	—	RES	GPDENB	NETSEL	LREFENB	LREFIFS	LREFIBC	CED	GFME

Symbol	Bit	Description
Reserved	7	Reserved.
GPDENB	6	0: Disables the GPD register. 1: Enables the GPD register.
NETSEL	5	0: Select NETREF_1. 1: Select NETREF_2.
LREFENB	4	0: LREF's are 8 unsynchronized inputs. 1: LREF's are 4 pairs of synchronized inputs.
LREFIFS	3	0: LREF frame strobe is not inverted. 1: LREF frame strobe is inverted.
LREFIBC	2	0: LREF bit clock is not inverted. 1: LREF bit clock is inverted.
CED	1	0: Individual FME bits are used for all transfers. 1: Value of GFME (CON register bit 0) is used for all transfers.
GFME	0	0: Only reverse connections provide constant delay. 1: Only forward connections provide constant delay.

2 Architecture and Functional Description (continued)

2.5 Clocking Section (continued)

2.5.9 LREF Pairing

The *Ambassador* devices have a feature which is programmable by software called LREF pairing (a pair of pins). This means that a pair of synchronizing clocks (a bit clock and a frame clock) can be input through the LREF port, and the T810X will phase-lock and derive all of its timing from them. LREF pairing can be considered as an extension to the CT_C8A, CT_C8B, and CT_FRAME_A, CT_FRAME_B pairs of clocks. When this option is selected, the onboard DPLL is bypassed and the LREF frame input becomes the internal frame synchronization clock. The LREF bit clock is routed to the dividers and finally to the analog PLL.

2.5.9.1 LREF Port Configuration

When LREF pairing is enabled (CON register, bit 4 = 1), the LREF port is configured as described in Table 53. The pairs must be used as listed in the table (they cannot be mixed and/or matched). In addition to the enable/disable control bit, the CON register has 2 additional control bits for inverting the frame strobe and bit clock.

Table 53. LREF Pairs

Input Pins	Description
LREF0 LREF4	Bit clock Frame synchronization clock
LREF1 LREF5	Bit clock Frame synchronization clock
LREF2 LREF6	Bit clock Frame synchronization clock
LREF3 LREF7	Bit clock Frame synchronization clock

Table 54. CKM (0x00) CKSEL Values to Select LREF Pairs

To use LREF pairing, the bits 3:0 (CKSEL) in the CKM register must be programmed to one of the following values to select one of the LREF pairs as the input.

Symbol	Bit	Description
CKSEL	3—0	CKSEL = 1000, sets LREF0 as bit clock input and sets LREF4 as frame sync input. CKSEL = 1001, sets LREF1 as bit clock input and sets LREF5 as frame sync input. CKSEL = 1010, sets LREF2 as bit clock input and sets LREF6 as frame sync input. CKSEL = 1011, sets LREF3 as bit clock input and sets LREF7 as frame sync input.

Notes:

1. If the CKSEL value is LREF4—LREF7 (0x1100—0x1111) as the input source, LREF pairing will not function.
2. CKSEL must be programmed to select LREF0—LREF3 in order to have LREF pairing.
3. Each LREF pair must be phase-locked together. Otherwise, the device timing will function incorrectly, causing unpredictable results.

2 Architecture and Functional Description (continued)

2.5 Clocking Section (continued)

2.5.9 LREF Pairing (continued)

2.5.9.2 Operation

If LREF pairing is enabled and CKM has a CKSEL value of 0x1000 to 0x1011, then the corresponding internal frame event is sent to the main clock generation circuit in order for the internally generated clocks to synchronize to the frame event. The T8100A, T8102, and T8105 only synchronize to the frame inputs on LREF[7:4]. The frame input on LREF[7:4] becomes the internal frame synchronization signal. Also, since the devices will derive their timing from the bit clock input on LREF[3:0], the divider(s) and CKR must be programmed.

The inverting bit in the CON register, bit 2, causes the bit clock to be inverted. This allows the sampling of the frame (LREF[7:4]) to occur on either the rising or falling edge of the bit clock input on LREF[3:0]. The inverting bit in the CON register, bit 3, causes the frame clock to be inverted. This allows the internal clock generator to synchronize to either a rising or falling transition of the frame input on LREF[7:4].

The divider registers must be set up for the correct divide factor. The register that is programmed depends on which path is chosen. If the LREF bit clock is, for example, 8.192 MHz and it is not going to be sent to the PRIREFOUT for external jitter attenuation, then the resource divider would be programmed. A value of 0x03 gives a divide by 4, and the input to the analog PLL is 2.048 MHz. The CKR register also has to be programmed for the correct PLL multiplier. Another feature of LREF pairing is that the bit clock does not have to be 8.192 MHz. For example, a 1.544 MHz clock can be input, sent to PRIREFOUT, and converted to a 2.048 MHz clock, which is then input on the 4MHzIN pin.

2.5.9.3 Example of LREF Pairing on a T8100A

- The T8100A PCI card has a framer on it and two phase-locked clock outputs:
 - An 8 kHz frame clock going to LREF4.
 - An 8.192 MHz bit clock going to LREF0.
- The CON register is programmed for LREF pairing: LREFENB bit 4 = 1.
- The frame strobe and the bit clock are not inverted, so LREFIFS bit 3 = 0 and LREFIBC bit 2 = 0.
- The CKM register is programmed to be a master with phase and snap alignment, and CKSEL[3:0] is set for LREF0. The value of CKM is, therefore, 0xA8.

- CKR is programmed to 0x50, which sets the PLL multiplier to 32.
- The resource divider, CKRD, is programmed to 0x03, which divides the 8.192 MHz clock by 4.
- The T8100A derives its memory and state machine clocks from the 8.192 MHz input on LREF0.
- The frame synchronization clock will be input to the state machines, and the T8100A will phase lock to the framer's 8 kHz clock that is input on LREF4.

2.5.9.4 Advantages of LREF Pairing

LREF pairing provides the user of the T8100A, T8102, or T8105 with another option for selecting a pair of clocks from which to derive internal timing. With the use of the CON register, the user has a very flexible arrangement regarding the orientation of the LREF pair that can be input to the T8100A, T8102, or T8105.

2.6 Interface Section

2.6.1 Microprocessor Interface

The grouping of the read, write, chip select, and address latch enable signals, along with the data bus and the address bus, permit access to the devices using *Intel* nonmultiplexed interface (ALE = low), *Motorola* nonmultiplexed interface (ALE = high), or *Intel* multiplexed interface (ALE = active). ALE controls the microprocessor mode. All control and status registers and data and connection memory accesses are controlled through this interface. All accesses are indirect, following the pin descriptions in Table 1 and Table 2. Programming examples and a more detailed discussion of the indirect accesses can be found in Section 3 Using the TSI Devices.

2.6.2 General-Purpose Register

A simple, general-purpose I/O register is available. The GPR has eight dedicated pins. The GPR corresponds with I/O pins GP[0:7]. GP6 and GP7 are unavailable if bit 5 of register CKN is low (see Section 2.5.8 Clock Control Register Definitions).

The GPD register (0x17) is a write-only register. It sets the direction bit in the GPR register (0x18). To verify what is written to the GPD register, the GPR register has to be read and the direction bits checked. If a bit in the GPD is zero, the corresponding bit in the GPR is set to one and the pin is configured as an input. If a bit in the GPD is a one, then the corresponding bit in the GPR is zero and the pin is configured as an output. Also, bit 6 in the CON register (0x0E) must be set to one to enable writing of the GPD register. Since the GPD is a write-only register, software will have to keep track of the current GPR settings, which reflect what is in the GPD.

2 Architecture and Functional Description (continued)

2.6 Interface Section (continued)

2.6.3 Framing Groups

The framing group signals are another feature of the T8100A/02/05 devices. With the 11-bit offset, the start of the first frame pulse can be positioned anywhere within the frame: therefore, simply defining the start of a virtual frame. Since there are 12 signals for each group and there are two groups, the user has great flexibility when interfacing to other telephony cards.

Two groups of frame pulses are available. Each frame group consists of 12 lines which are enabled sequentially after a programmed starting point. They are denoted as group A and group B. This section describes framing group A. Framing group B is made up of similar registers. Each frame group is controlled by a pair of registers: FRHA and FRLA control the spacing of the 12 frame pulses, their pulse width, polarity, and the offset of the first pulse from the frame boundary.

Table 55. FRHA, Frame Group A High Address and Control, 0x21

Reg	R/W	Bit 7	Bit 6	Bit 5	Bit 4	Bit 3	Bit 2	Bit 1	Bit 0
FRHA	—	Rate		Type		FAI	Hi Start		

Symbol	Bit	Description		
Rate	7—6	Rate = 00,	Frame group disabled, 3-state.	
		Rate = 01,	2.048 Mbits/s.	
		Rate = 10,	4.096 Mbits/s.	
		Rate = 11,	8.192 Mbits/s.	
Type	5—4	Type = 00,	Bit-wide pulse.	
		Type = 01,	Double bit-wide pulse.	
		Type = 10,	Byte-wide pulse.	
		Type = 11,	Double byte-wide pulse.	
FAI	3	FAI = 0,	Normal pulse.	
		FAI = 1,	Inverted pulse.	
Hi Start	2—0	Hi Start =	Upper 3 bits of group start address or programmed output.	

Table 56. FRHB, Frame Group B High Address and Control, 0x23

Reg	R/W	Bit 7	Bit 6	Bit 5	Bit 4	Bit 3	Bit 2	Bit 1	Bit 0
FRHB	—	Rate		Type		FAI	Hi Start		

Symbol	Bit	Description		
Rate	7—6	Rate = 00,	Frame group disabled, 3-state.	
		Rate = 01,	2.048 Mbits/s.	
		Rate = 10,	4.096 Mbits/s.	
		Rate = 11,	8.192 Mbits/s.	
Type	5—4	Type = 00,	Bit-wide pulse.	
		Type = 01,	Double bit-wide pulse.	
		Type = 10,	Byte-wide pulse.	
		Type = 11,	Double byte-wide pulse.	
FAI	3	FAI = 0,	Normal pulse.	
		FAI = 1,	Inverted pulse.	
Hi Start	2—0	Hi Start =	Upper 3 bits of group start address.	

2 Architecture and Functional Description (continued)

2.6 Interface Section (continued)

2.6.3 Framing Groups (continued)

There are two groups of frame pulses. Each frame group consists of 12 output pins, which are enabled sequentially after a programmed starting point. The 12 outputs of the frame group are pulsed in sequence, once every 8 bit times, where the bit time is set by the rate option. The groups are denoted group A and group B. This section describes framing group A. Framing group B is made up of similar registers. A pair of registers controls each group. Two registers, FRLA and FRHA, control the spacing of the 12 frame pulses (rate), their pulse width, polarity, and the offset of the first pulse from the frame boundary. The FRPL and FRPH registers are also used in configuring the frame groups; however, for this discussion they are equal to zero. With FRPL and FRPH equal to zero, the frame group A bits [0:11] are output on pins FGA[0:11] and frame group B bits are routed to group B output pins FGB[0:11]. FRHA has 5 control bits and 3 upper offset bits. FRLA has 8 bits for the lower part of the offset. Thus, the offset is 11 bits. The 11-bit offset corresponds to 2^{11} values which allow programming offsets from 0 ns to 125 μ s. Note that the resolution is less than 1 data bit. For example, if the frame group clock is programmed to 2.048 MHz, the resolution is 0.125 (one eighth) of a data bit.

2.6.3.1 Frame Group Timing

The frame boundary is the point where /CT_FRAME is low and CT_C8 is starting its low-to-high transition.

The offset sets the first output (pin FGA0) relative to the frame boundary. With a zero offset, the rising edge of the first frame group is coincident with the first falling edge of the 8.192 MHz clock, output at the LS_C[3:0] port, after the start of the frame boundary.

Referring to Figure 28, the rising edges of the 8.192 MHz, 4.096 MHz, and 2.048 MHz clocks are all coincident and occur in the center of CT_FRAME (not shown in Figure 28). This is the start of the following:

- Physical frame.
- The first data bit of the first time slot on the CT bus and the local bus.

Because of the complexity of the device and other design considerations, with a frame group offset of zero, the first frame pulse starts after 1 bit clock (1/16.384 MHz) with respect to the start of the frame boundary.

To have the frame group start at the frame boundary, the 11-bit offset is all ones (0x7FF). That is, FRLA is 0xFF and the lower 3 bits (bits [2:0]) of FRHA are 1. The 11-bit offset allows the user to position the starting frame pulse anywhere within the 125 ms frame. The frame pulse can be adjusted in increments of 61 ns (1/16.384 MHz). The control bits in the FRHA register enable the user to invert the frame group pulse and to adjust the width of these pulses.

In addition to sequenced pulses, the frame groups can be used as simple programmed output registers. When group A is used as a programmed output, the bits are sent from the FRLA [0x20] and FRHA [0x21] registers. Bits [0:7] of the programmed output come from bits [0:7] of FRLA [0x20]. Bits [8:10] of the programmed output come from the high start (bits [0:2]) of FRHA [0x21], and bit 11 of the programmed output comes from the FAI bit (bit 3) of FRHA [0x21]. When group B is used as a programmed output, bits 0:7 of the output come from bits 0:7 of separate register FRPL [0x24], and bits [8:11] of the output come from bits 0:3 of another register FRPH [0x25]. The upper nibble of FRPH [0x25] also has output routing functions associated with it. Register FRPH [0x25] is illustrated in Table 57; see Figure 19 for a diagram of the selection options.

2 Architecture and Functional Description (continued)

2.6 Interface Section (continued)

2.6.3 Framing Groups (continued)

2.6.3.1 Frame Group Timing (continued)

Table 57. FRPH: Frame Group B, Programmed Output, High, 0x25

Reg	R/W	Bit 7	Bit 6	Bit 5	Bit 4	Bit 3	Bit 2	Bit 1	Bit 0
FRPH	—	FAO		RES	FBO	Hi Prog			

Symbol	Bit	Description
FAO	7—6	FAO = 00, Frame group A bits FGA[0:11] on output pins FGA[0:11]. FAO = 01, Programmed output A bits FGA[0:11] on output pins FGA[0:11]. FAO = 10, Frame group A bits FGA[0:5] on output pins FGA[0:5], and frame group B bits FGA[0:5] on output pins FGA[6:11]. FAO = 11, Programmed output A bits FGA[0:5] on output pins FGA[0:5], and frame group B bits FGA[0:5] on output pins FGA[6:11].
RES	5	(Reserved.)
FBO	4	FBO = 0, Frame group B routed to group B output pins. FBO = 1, Programmed output B routed to group B output pins.
Hi Prog	3—0	Hi Prog = Upper 4 bits of programmed output B. In the programmed output mode, the rate must not equal 00; otherwise, the outputs corresponding to the group bits are 3-stated; the rate will have no effect other than enabling the mode. Type bits have no effect in the programmed modes.

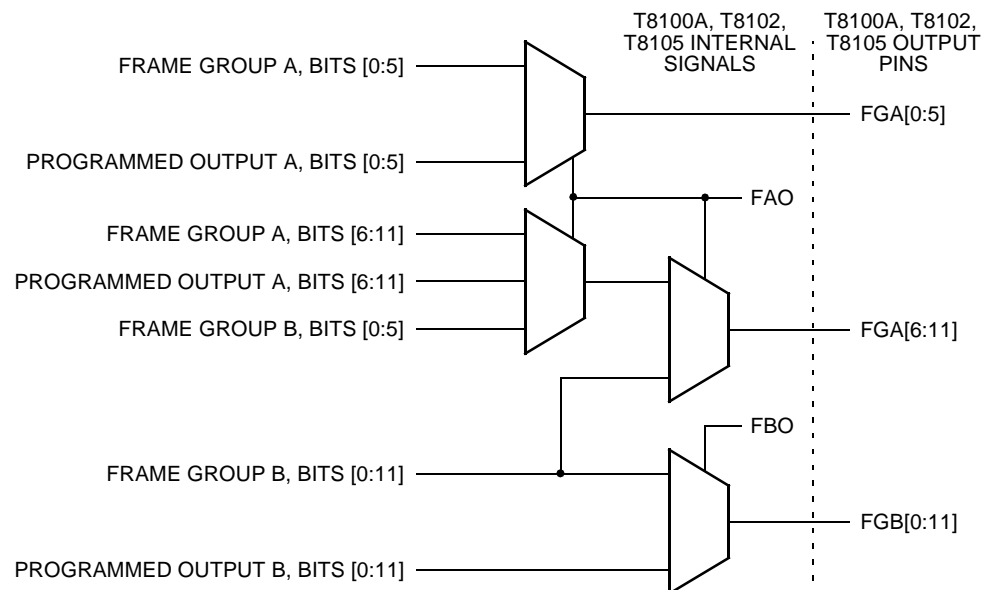

5-6113F

Figure 19. Frame Group Output Options

2 Architecture and Functional Description (continued)

2.7 Error Registers

The devices have five error registers:

- CLKERR1 [0x28]
- CLKERR2 [0x29]
- CLKERR3 [0x2C]
- CKW [0x2B]
- SYSERR [0x2A]

When programming the clock registers, writing to CKW and CKS should be programmed last.

These are the clock error, watchdog enable, and system error registers. The CLKERR1 register is used to indicate failing clocks, and the CLKERR2 indicates whether the failure is permanent or transient in nature. If the clocks fail, i.e., disappear or momentarily drop out, then corresponding bits in both registers will be set. If the clock is reestablished, i.e., a transient error, then the T bit(s) will clear, but the E bit(s) will remain set. All of the E bits are ORed together and drive the CLKERR pin.

The clocks listed in Table 58 are sampled by the 16.384 MHz internal clock. Effectively, each clock has a watchdog. If the clock is switching, the watchdog clears. If the clocks stop, then the watchdog sets the

appropriate E and T bits. If the clock is re-established, then the E bits remain stuck, but the T bits clear with the watchdog. Since fallback is triggered on the E bits, a transient clock can force a fallback. The CT_C8A and CT_C8B watchdogs sample both rising and falling edges at a 32.768 MHz sample rate (crystal oscillator input multiplied by 2) in order to meet the ECTF H.110 specification of detecting a missing received rising edge within 35 ns. The /C16+, /C16-, /C4, C2, SCLK, SCLKX2 watchdog does not have this ECTF H.110 specification. Each clock is divided down to 1 MHz and are monitored for a loss of signal at 1 MHz.

The CT_FRAMEA, CT_FRAMEB, /FR_COMP, CT_NETREF1, and CT_NETREF2 watchdog circuitry is simply a counter. If there is an 8 kHz input on CT_NETREF, for example, every rising edge of the 8 kHz triggers an internal counter. This counter counts up to some value. If the terminal count is reached, an error will be reported. The circuitry does not look at the input signal CT_NETREF for some polarity. The assumption is, if the counter reached terminal count there is no CT_NETREF. If there was a CT_NETREF, the counter would not have reached terminal count because the counter would have been reset.

CT_NETREF 1 and 2 are reported if there is no switching on CT_NETREF for 125 μs. If CT_NETREF is set to a frequency other than 8 kHz, the error bits NRE and NRT should not be used to monitor for a clock failure.

Table 58. CLKERR1 and CLKERR2: Error Indicator and Current Status, 0x28 and 0x29

Table 58 describes both CLKERR1 and CLKERR2.

Symbol	Bit	Description
CAE CAT	7	CA => Reports failures on CT_C8A or /CT_FRAMEA.
CBE CBT	6	CB => Reports failures on CT_C8B or /CT_FRAMEB.
CFE CFT	5	CF => Reports failures on /FR_COMP.
C16E C16T	4	C16 => Reports failures on /C16+ or /C16-.
C42E C42T	3	C42 => Reports failures on /C4 or C2.
SCE SCT	2	SC => Reports failures on SCLK.
SC2E SC2T	1	SC2 => Reports failures on SCLKX2.
NRE NRT	0	NR => Reports failures on CT_NETREF1 or CT_NETREF2. 8 kHz only.

2 Architecture and Functional Description (continued)

2.7 Error Registers (continued)

The CKW register works in conjunction with the two registers above and with the clock circuitry. It is used to enable the watchdogs for the clock lines. CKW uses the same mapping as CLKERR1 and CLKERR2, so, for example, a high in bit 7 will enable the watchdogs for CT_C8A and /CT_FRAMEA. CKW functions as a masking register for CLKERR1 and CLKERR2. If the appropriate bit is not set, then a failing clock will not be reported. CLKERR3 bit 0 functions as the mask bit for CT_NETREF2 errors.

The SYSERR and CLKERR1 bits, when set, will remain set until they are reset. To reset and clear the two registers, set the corresponding bit(s) in the MCR (see Section 2.1 Register/Memory Maps). When clearing the MCR registers, it takes between one and two state machine clock cycles (15.25 ns to 30.5 ns) from the trailing edge of WRn strobe to assertion of the internal CER/SER strobes. These internal strobes immediately (asynchronously) reset their respective registers.

Table 59. CLKERR3: Error Indicator and Current Status, 0x2C

Reg	R/W	Bit 7	Bit 6	Bit 5	Bit 4	Bit 3	Bit 2	Bit 1	Bit 0
CLKERR3	R/W	RES		N2E	N1E	RES		N2N	

Symbol	Bit	Description
RES	7—6	Reserved bit position. Read only.
N2E	5	Read only. N2E => Reports failures on CT_NETREF2.
N1E	4	Read only. N1E => Reports failures on CT_NETREF1.
RES	3—1	Reserved bit position. Read/write.
N2N	0	Read/write. N2N = 0, Disable error reporting on NETREF2. N2N = 1, Enable error reporting on NETREF2.

Note: Bits [7:4] are read only, bits [3:0] are read/write.

Table 60. SYSERR: System Error Register, 0x2A

Reg	R/W	Bit 7	Bit 6	Bit 5	Bit 4	Bit 3	Bit 2	Bit 1	Bit 0
SYSERR	—	CUE	CUO	CUL	COE	COO	COL	RES	FBE

Symbol	Bit	Description
CUE	7	CUE => Even CAM underflow, set by an unmatched comparison.
CUO	6	CUO => Odd CAM underflow, set by an unmatched comparison.
CUL	5	CUL => Local CAM underflow, set by an unmatched comparison.
COE	4	COE => Even CAM overflow, set by a write to a full CAM.
COO	3	COO => Odd CAM overflow, set by a write to a full CAM.
COL	2	COL => Local CAM overflow, set by a write to a full CAM.
RES	1	RES => Reserved bit position.
FBE	0	FBE => Fallback enabled, status which indicates that a clock error has occurred and fallback operations are in effect*.

* This error bit is selective. It will only flag an error if the clocks that fail correspond to the selected clock mode. For example, if *MVIP* mode is selected (in register CKM), the proper fallback mode has been set (in register CKS), and the *MVIP* clocks are not masked (register CKW, above), then FBE will go high when a failure is detected on /FR_COMPn, C2, or /C4. Thus, unmasked, failing non-*MVIP* clocks will be flagged in the CLKERR1 and CLKERR2 registers but will not set the FBE flag in SYSERR.

2 Architecture and Functional Description (continued)

2.8 The JTAG Test Access Port

2.8.1 Overview of the JTAG Architecture

Tap	A 5-pin test access port, consisting of input pins TCK, TMS, TDI, TDO, and TRST, provides the standard interface to the test logic. TRST is an active-low signal that resets the circuit.
TAP Controller	The TAP controller implements the finite state machine which controls the operation of the test logic as defined by the standard. The TMS input value sampled on the rising edge of TCK controls the state transitions. The state diagram underlying the TAP controller is shown below.
Instruction Register (JIR)	A 3-bit scannable JTAG instruction register that communicates data or commands between the TAP and the devices during test or HDS operations.
Boundary-Scan Register (JBSR)	A 211-bit JTAG boundary-scan register containing one scannable register cell for every I/O pin and every 3-state enable signal of the device, as defined by the standard. JBSR can capture from parallel inputs or update into parallel outputs for every cell in the scan path. JBSR may be configured into three standard modes of operation (EXTEST, INTEST, and SAMPLE) by scanning the proper instruction code into the instruction register (JIR). An in-depth treatment of the boundary-scan register, its physical structure, and its different cell types is given in Table 62.
Bypass Register (JBPR)	A 1-bit long JTAG bypass register to bypass the boundary-scan path of nontargeted devices in board environments as defined by the standard.

2.8.2 Overview of the JTAG Instructions

The JTAG block supports the public instructions as shown in the table below.

Table 61. JTAG Instruction Set

Instruction Mnemonics	Instruction Codes	Public/Private	Description
EXTEST	000	Public	Select B-S register in extest mode
SAMPLE	001	Public	Select B-S register in sample mode
Reserved	010	—	—
Reserved	011	—	—
Reserved	100	—	—
Reserved	101	—	—
Reserved	110	—	—
BYPASS	111	Public	Select BYPASS register

2 Architecture and Functional Description (continued)

2.8 The JTAG Test Access Port (continued)

2.8.3 Elements of JTAG Logic

The signal TRST, which is used for resetting the JTAG TAP controller, must be asserted to make the simulation model (VHDL or *Verilog** or encrypted *Verilog*) operate. Since the TAP controller does not always power up in normal mode, the TPA controller has to be reset. Resetting the TAP controller is done by asserting TRST (brought low) and keeping it low throughout the test.

Table 62. JTAG Scan Register

Cell	Type	Signal Name/Function
66	I	CK_3MHZIN
67	O	SYSERR
68	O	CLKERR
0	CC	Controls cells 67:68
69—76	Bdir	D[0:7]
1	CC	Controls cells 69:76
77	I	RESTN
78	O	RDY
79	I	WRN
80	I	RDN
81	I	CSN
82	I	ALE
83	I	A0
84	I	A1
85—88	O	L_SC[0:3]
44	CC	Controls cells 85:88
89—96	I	L_REF[0:7]
97	I	CK_4MHZIN
98	O	PRIREFOUT
45	CC	Controls cell 98
99	O	TESTOUT1
100	O	REFCLK1O
46	CC	Controls cells 99, 100
101	Bdir	FROMDJAT
43	CC	Controls cell 101
102	Bdir	TODJAT
42	CC	Controls cell 102
103—108	Bdir	GP[5:0]
41	CC	Controls cells 103—108
109—120	O	FGB[11:0]
63	CC	Controls cells 109—120

Cell	Type	Signal Name/Function
121—132	O	FGA[11:0]
64	CC	Controls cells 121—132
133	Bdir	C16N_MINUSA
134	Bdir	C16N_PLUSA
135	Bdir	C4N
136	Bdir	C2
5	CC	Controls cells 133—136
137	Bdir	SCLKX2NA
7	CC	Controls cell 137
138	Bdir	SCLKA
6	CC	Controls cell 138
139	Bdir	CT_C8_BA
140	Bdir	CT_FRAME_BNA
3	CC	Controls cells 139—140
141	Bdir	FRN_COMPA
4	CC	Controls cell 141
142	Bdir	CT_NETREF
8	CC	Controls cell 142
143	Bdir	CT_C8_AA
144	Bdir	CT_FRAME_ANA
2	CC	Controls cells 143—144
145—176	Bdir	CT_D[0:31]
9—40	CC	Controls cells 145—176
177—192	O	LDO[0:15]
47—62	CC	Controls cells 177—192
193	O	XCS
0	CC	Controls cell 193
194—209	I	LDI[0:15]
210	O	TCLKOUT
65	CC	Controls cell 65

* *Verilog* is registered trademark of Cadence Design Systems, Inc.

2 Architecture and Functional Description (continued)

2.9 Testing and Diagnostics

The devices have several testing operations:

- JTAG
- Forced output testing
- Onboard diagnostics

During manufacturing, the devices are run through standard functional and electrical testing.

2.9.1 Testing Operations

JTAG is used primarily to test the array portion of the devices. It will not provide coverage for the CAMs, register files, SRAMs, or PLLs. In JTAG, the manufacturer provides a drop-in control block and scan-chain which ties internal points to registers on the periphery of the devices, which are, in turn, tied to the I/O pins. Serial bit patterns are shifted into the devices through the TDI pin, and the results can be observed at the I/O and at a corresponding JTAG serial output, TDO. Since this JTAG conforms to the JTAG standard, the TDI and TDO can be linked to the JTAGs of other devices for systemic testing. The TTS pin must be low for JTAG operations to work. The TTS pin has an internal pull-down resistor that defaults the devices to JTAG operations.

In forced output testing, the outputs are set to a particular state to measure their dc parameters. This can also be used in applications for board-level diagnostics. Forced output testing is selected by setting the TTS (test type select) pin high. In this mode, the JTAG clock pin, TCLK, will act as an input pin. All outputs will be enabled, and each output provides either an inverting or normal response to the input pin. Adjacent pins alternate inverting and normal function (i.e., a checkerboard pattern).

2.9.2 Diagnostics

The devices have onboard diagnostic modes for testing the frame groups, SRAMs and CAMs, and some internal structures. These are intended for testing some of the devices' resources while in an application environment (rather than a manufacturing test environment).

The diagnostics allow critical internal nodes to be output through the frame groups, or to have the frame groups operated in special cyclical manner, or to provide automatic filling of all memories (including CAMs) with one of four selected patterns. The diagnostics are activated and selected using three registers: DIAG1 [0x30], DIAG2 [0x31], or DIAG3 [0x32].

DIAG1 is used to select the frame group pins as either monitors for internal nodes or normal operation (i.e., as frame groups or programmed outputs). DIAG1 is also used to control the memory fill diagnostic.

DIAG2 and DIAG3 modify the normal operation of the frame groups and the main state counter. Normally, the frame groups begin their cascade sequence when the state counter (i.e., the frame-synchronized master counter of the devices) reaches a value equal to the frame group's starting address. DIAG2 and DIAG3 allow the state counter to be modified for one of two different tests.

When using the diagnostics in the pattern fill modes, refer to Appendix C.

2 Architecture and Functional Description (continued)

2.9 Testing and Diagnostics (continued)

2.9.2 Diagnostics (continued)

Table 63. DIAG1: Diagnostics Register 1, 0x30

Reg	R/W	Bit 7	Bit 6	Bit 5	Bit 4	Bit 3	Bit 2	Bit 1	Bit 0
DIAG1	—	DFA		DFB		DMF	DMP		DMD

Symbol	Bit	Description
DFA	7—6	<p>DFA: Diagnostics, Frame Pin Selects, Group A</p> <p>DFA = 00, Normal operation.</p> <p>DFA = 01, State counter bits [10:0] routed to frame group pins [10:0], pin 11 = L.</p> <p>DFA = 10, Even CAM hit routed to pin 11, pin 10 has odd CAM hit, pins [9:0] have local data memory address.</p> <p>DFA = 11, Pin 11 gets CUE error bit, pin 10 gets CUO error bit, pin 9 gets CUL error bit, pin 8 gets COE error bit, pins [5:0] get page pointers—8 MHz read, 8 MHz write, 4 MHz read, 4 MHz write, 2 MHz read, and 2 MHz write.</p>
DFB	5—4	<p>DFB: Diagnostics, Frame Pin Selects, Group B</p> <p>DFB = 00, Normal operation.</p> <p>DFB = 01, State counter bits [10:0] routed to frame group pins [10:0], pin 11 = L.</p> <p>DFB = 10, CAM state register [1:0] indicating four substates, routed to pins [11:10], and local connection memory (T8100A, T8105 only) address routed to pins [9:0].</p> <p>DFB = 11, Pin 11 gets local CAM hit flag, and pins [10:0] get CAM state counter.</p>
DMF	3	<p>DMF: Diagnostics, Memory, Fill Test Enable</p> <p>DMF = 0, Normal operation.</p> <p>DMF = 1, Fill all memories with the pattern selected by DMP.</p>
DMP	2—1	<p>DMP: Diagnostics, Memory, Fill Test Pattern Select</p> <p>DMP = 00, Checkerboard 0—even locations get 0x55, odd locations get 0xAA.</p> <p>DMP = 01, Checkerboard 1—even locations get 0xAA, odd locations get 0x55.</p> <p>DMP = 10, Data locations equal address bits [7:0]. (CAMs are filled with their physical address.)</p> <p>DMP = 11, Data locations equal inverted address bits [7:0].</p>
DMD	0	<p>This is a status bit which indicates that the chosen memory pattern has been written to all locations. Additional writes to the memory are disabled and reads are enabled. This condition remains until the user clears this bit.</p>

2 Architecture and Functional Description (continued)

2.9 Testing and Diagnostics (continued)

2.9.2 Diagnostics (continued)

Table 64. DIAG2: Diagnostics Register 2, 0x31

Reg	R/W	Bit 7	Bit 6	Bit 5	Bit 4	Bit 3	Bit 2	Bit 1	Bit 0
DIAG2	—	DFC	DSB	DXF	RES	DSE		DSH	

Symbol	Bit	Description
DFC	7	DFC: Diagnostics, Frame Groups Cycle Test DFC = 0, Normal operation. DFC = 1, Cycle test mode enabled; forces the frame groups to constantly cycle without waiting for a frame signal to synchronize the start.
DSB	6	DSB: Diagnostics, State Counter, Break Carry Bits DSB = 0, Normal operation. DSB = 1, Breaks the carry bits between the subsections of the state counter so that the state counter is operating as three counters running in parallel. (This can be viewed on the frame pins using the DF _n = 01 selection described above.) Status counter bits [0:3] and [4:7] run as modulo-16 counters, and bits [8:10] run as a modulo-8 counter.
DXF	5	DXF: Diagnostics, External Frame Input DXF = 0, Normal operation. DXF = 1, Forces /FR_COMP to act as a direct input signal for devices framing. This effectively bypasses the internally generated frame signal. The user is again cautioned since the external frame can operate asynchronously to the generated clocks if care is not taken.
RES	4	(Reserved.)
DSE	3—2	DSE: Diagnostics, External Frame Input DSE = 0, Normal operation. DSE = 1, Forces the state counter to load the value held in DSH and DSL and continuously cycle as a modulo-n counter where the n value is determined by (DSH and DSL). With the DSE pin high, the state counter is no longer synchronized to the frame signal.
DSH	1—0	DSH: Diagnostics, State Counter, High Bits of Parallel Load State counter bits [10:8].

Table 65. DIAG3: Diagnostics Register 3, 0x32

Reg	R/W	Bit 7	Bit 6	Bit 5	Bit 4	Bit 3	Bit 2	Bit 1	Bit 0
DSL	—	DSL							

Symbol	Bit	Description
DSL	7—0	State counter bits [7:0].

3 Using the TSI Devices

3.1 Resets

3.1.1 Hardware Reset

A hardware reset utilizes the (active-low) $\overline{\text{RESET}}$ pin. On activation, it immediately places all outputs into 3-state. Individual output sections must be re-enabled by setting the appropriate bits high in the MCR register. Internally, the local memory (T8100A, T8105 only) is in an undefined state, all CAM empty bits are set, all state machines are reset, and all registers are cleared to zero.

3.1.2 Software Reset

This is accomplished by setting the MSB of the master control and status register (see Section 2.1.2 Master Control and Status Register). The local and H-bus connections are rendered invalid, all registers are cleared except MCR, CLKERR1, CLKERR2, CLKERR3, and SYSERR (these registers are cleared with separate MCR control bits); the state machines are also reset. Writing the value 0xE0 to the MCR is a full software reset. Writing 0x0E enables all pin groups (though individual pins still require setup). This soft reset is clocked by the crystal.

3.1.3 Power-On Reset

No power-on reset is available. It is expected that the host microprocessor or applications board will provide an external control to the $\overline{\text{RESET}}$ pin for performing a hardware reset. The PLLs must not be enabled prior to establishing a stable supply voltage. There are two methods to accomplish this:

- Tie the En1 and En2 pins to the same line that drives the $\overline{\text{RESET}}$, which forces the PLLs into an off condition while the devices reset asynchronously.
- Add external capacitors from En1 to ground and from En2 to ground. (The values of the capacitors should be 1 μF or greater.) The capacitors will form RC circuits with the En1 and En2 internal pull-ups and will charge up to enable the PLLs after several milliseconds. The RC circuit affects the power-on reset for the PLLs. The long rise time provides some delay.

3 Using the TSI Devices (continued)

3.2 Device Settings

3.2.1 Architecture

Table 66. Device Identification Register, 0xFE

Version device identification always identifies the physical device type.

Reg	R/W	Bit 7	Bit 6	Bit 5	Bit 4	Bit 3	Bit 2	Bit 1	Bit 0
REV_ID	R	Device Identification Number				Device Version Number			

Name	Bit	Description
REV_ID Device Identification Number	7—4	Read only. 0000 = T8100A. 0001 = (Reserved) 0010 = T8102. 0011—0100 = (Reserved) 0101 = T8105. 0110—1111 = (Reserved)
REV_ID Device Version Number	3—0	Read only. Rev_ID = 0001, = Version 1. Rev_ID = 0010, = Version 2, etc.

Table 67. GMODE: Global Mode Register, 0xFF

Readback of GMODE returns all 8 bits. Device type and function are determined by bits 3:0. Bits 7:4 are writable (bits returned on readback reflect what the user should have them set to for the various modes), bit 4 is reserved.

Reg	R/W	Bit 7	Bit 6	Bit 5	Bit 4	Bit 3	Bit 2	Bit 1	Bit 0
GMODE	R/W	Mode Emulation 2 & 1 (ME2 & ME1)		Subrate Enable (SE)	RES	EMUL[3:0]			

Name	Bit	Description
ME[2:1]	7—6	Read/write. Only the T8105 can be written to emulate either a T8102 or a T8100A. ME[2:1] = 00, T8105. ME[2:1] = 01, T8102, 512 connections (no local connections). ME[2:1] = 10, T8100A, converts 512 connections to 256 connections. ME[2:1] = 11, (Reserved)
SE	5	Read/write. SE = 0, Subrate disabled. SE = 1, Subrate enabled.
RES	4	Reserved bit position. Read/write.
EMUL	3—0	Read only. Changing the emulation is reflected in the lower 4 bits of the GMODE. The DIR is not changed. EMUL = 0000, (Reserved) EMUL = 0001, (Reserved) EMUL = 0010, T8100A emulation mode. EMUL = 0011, T8105 (512 connections). EMUL = 0100—0110, (Reserved) EMUL = 0111, T8102 emulation mode. EMUL = 1000—1100, (Reserved) EMUL = 1101, T8102. EMUL = 1111, (Reserved)

3 Using the TSI Devices (continued)

3.3 Basic Connections

At a minimum, the devices require power, ground, and a 16.384 MHz crystal (or 16.384 MHz oscillator). It is also recommended that the internal PLLs be treated as other analog circuits are, so the user should provide the appropriate filtering between the PLL1V_{DD} and V_{DD} pins (as well as PLL2V_{DD} and V_{DD} pins). The RDY pin is operated as an open collector output. It is actively driven low or into 3-state. The user should apply a pull-up (e.g., 10 k Ω) to maintain standard microprocessor interfacing. It is recommended that the 10 k Ω be tied to 3.3 V (since the device's nominal V_{OH} is 3.3 V), but the resistor may also be tied up to 5 V without damaging the device. A 33 μ F tantalum capacitor and 25 Ω series resistor are necessary to provide VCO stability in the PLLs. PLL connections are shown in Figure 20.

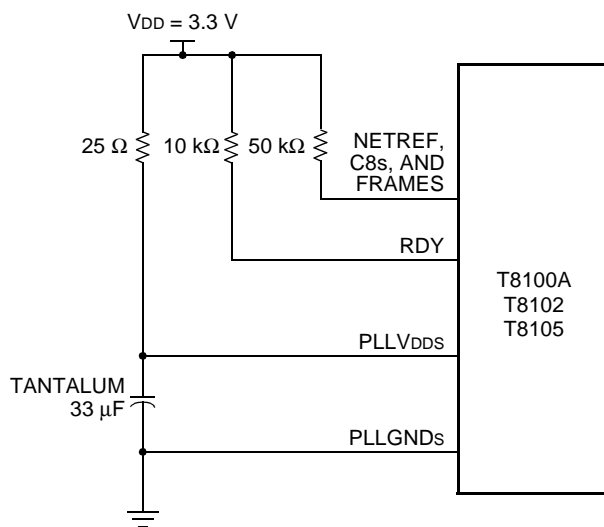

5-6114.aF

Figure 20. External Connection to PLLs

3.3.1 LPUE Control Pins

A list of 46 pull-ups which LPUE controls is shown in the table below. LPUE has a pull-up attached, so the default is pull-ups enabled.

LPUE is used as an assist to meet the *CompactPCI** Hot Swap specification. During live insertion/removal, the only devices that should be on are the power manager and interface parts (PCI interface attached to J1, H.110 interface attached to J4 on a *CompactPCI* chassis). Without the LPUE, anything connected to the T810x would get current flow from the early power through the pull-up resistors. When those parts power-up (late power), they already have current flowing through the I/O and latch-up may occur. Quick-switch parts were used for isolation on the earlier T8100 device, so when the T8100A/02/05 were designed, LPUE was added to break the current flow and eliminate the isolation switches. LPUE is typically tied to a pin on the *CompactPCI* power manager so that the pull ups are re-enabled with backside power turning on.

Table 68. LPUE Control Pins

Pin	Name	Pin	Name
1	3MHzIn	54	4MHzIn
22—15	D[7:0]	64	FromDJAT
24	$\overline{\text{RESET}}$	65	ToDJAT
26	$\overline{\text{WR}}$	66—71	GP[5:0]
27	$\overline{\text{RD}}$	192—185	LDI[7:0]
28	$\overline{\text{CS}}$	201—194	LDI[15:8]
45—38	L_REF[7:0]		

3.3.2 H.100/H.110 Data Pin Series Termination

All data bus lines must have a 24 Ω series resistor, even if only data lines 16—31 are used.

3.3.3 H.110 Hot Swap

When using the *Ambassador* in a hot-swap application, it is acceptable to power the PLLs after applying power to the chip. All hot-swap requirements are governed by the *CompactPCI* Hot Swap specification.

* *CompactPCI* is a registered trademark of the PCI Industrial Computer Manufacturers Group.

3 Using the TSI Devices (continued)

3.3 Basic Connections (continued)

3.3.4 Physical Connections for H.100

All H.100 bus signals must adhere to the specification, *ECTF H.100 Hardware Compatibility Specification: CT Bus*. The H.100 clock signals, CT_C8_A, CT_C8_B, /CT_FRAME_A, /CT_FRAME_B, and CT_NETREF, each require an individual external pull-up of 100 kΩ to 5 V or 50 kΩ to 3.3 V.

If CT_NETREF, CT_8A, CT_8B, CT_FRAME_A, or CT_FRAME_B are not going to be used, they must be tied to ground, V_{cc} or a pull-up resistor. They cannot be left floating, since they could oscillate.

3.3.5 Physical Connections for H.110

Figure 21 shows the physical connections required for use in an H.110 environment. There are electrical differences between H.100 and H.110. For H.110, external components are required to meet specifications. The specification is *ECTF H.110 Hardware Compatibility Specification: CT Bus*. Figure 21 shows the NETREF terminations and the required terminations for CT_C8A, CT_FRAMEA, CT_C8B, and CT_FRAMEB. Each signal has a mechanism to short the 33 Ω series resistor and, in addition, a 10 kΩ pull-down resistor. The 50 kΩ internal pull-ups on the CT data bus are used for H.100. For H.110, the DPUE pin should be tied low, disabling these internal pull-ups. H.110 requires the CT data bus to have pull-ups of 18 kΩ to 0.7 V. The control leads of the FET switches would typically go to the microprocessor.

3.3.6 PC Board BGA Considerations

There are no special requirements for the thermal balls on the BGA package when designing a printed-circuit board.

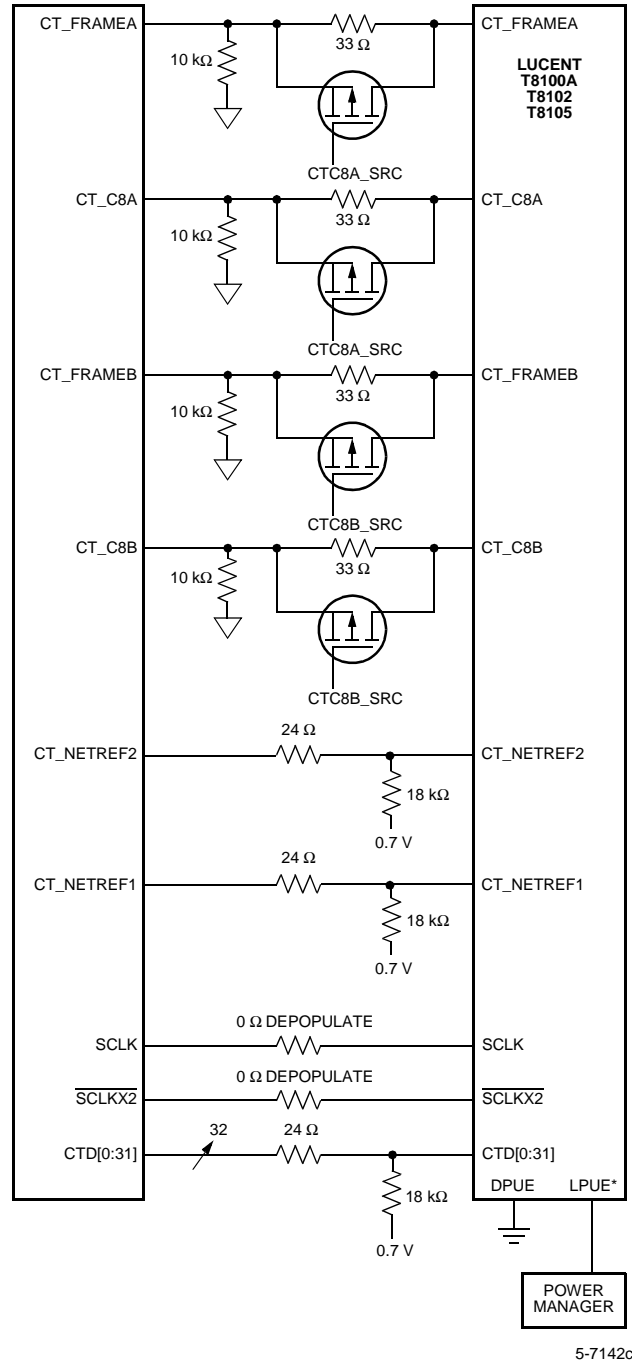

* Switched low for insertion/removal.

Figure 21. Physical Connections for H.110

3 Using the TSI Devices (continued)

3.4 Using the LAR, AMR, and IDR for Connections

3.4.1 Setting Up Local Connections (T8100A, T8105 Only)

Local connections require a physical location in the local connection memory corresponding to the output stream and time slot. The location contains a pointer to a local data memory location which holds the actual data that has come in or will be sent out. The local memories are based on 1024 locations, so 10 bits are required to specify the physical memory location where a connection is placed or where data is stored. To simplify the programming, the user supplies 11 bits in a stream and time-slot format, which is converted by the devices to the appropriate physical location. Relative to describing a connection, a data memory location corresponds with the FROM stream and time slot, and a connection memory location corresponds with the TO stream and time slot. To program a connection, the user loads the data memory location into the connection memory location, effectively identifying where the data resides.

The user programs 7 bits of the LAR for the time-slot value (or 8 bits for pattern mode) and the lowest 4 bits of the AMR for the stream value; these will then be converted to the physical memory address. The upper bits of the AMR select which field in the connection memory is being written into. Since the connection information itself is 15 bits, two transfers (i.e., two fields) must be made to the address in the connection memory.

In each case, the transfer is an indirect write of data to the indirect data register, the IDR: The first transfer is the lowest 7 bits (time-slot address) of the desired data memory location. It is placed in the IDR after the LAR and AMR have been set up with the appropriate connection address.

Table 69 illustrates the decoding of the time-slot bits (address value in the table refers to the hex value of the 7 bits comprising time slot).

When programming the registers for fallback, the CKS and CKW registers should be programmed last.

Table 69. Time-Slot Bit Decoding

Address Value	2 Mbits/s Time Slot	4 Mbits/s Time Slot	8 Mbits/s Time Slot
0x00	0	0	0
0x01	1	1	1
0x02	2	2	2
0x03	3	3	3
0x04	4	4	4
0x05	5	5	5
0x06	6	6	6
0x07	7	7	7
0x08	8	8	8
0x09	9	9	9
0x0A	10	10	10
0x0B	11	11	11
0x0C	12	12	12
0x0D	13	13	13
0x0E	14	14	14
0x0F	15	15	15
0x10	16	16	16
0x11	17	17	17
:	:	:	:
0x1E	30	30	30
0x1F	31	31	31
0x20	NA	32	32
:	:	:	:
0x3E	NA	62	62
0x3F	NA	63	63
0x40	NA	NA	64
:	:	:	:
0x7E	NA	NA	126
0x7F	NA	NA	127

3 Using the TSI Devices (continued)

3.4 Using the LAR, AMR, and IDR for Connections (continued)

3.4.1 Setting Up Local Connections (T8100A, T8105 Only) (continued)

Table 70. IDR: Indirect Data Register, Local Connections Only

The second transfer requires that data in the IDR be defined as follows.

Reg	R/W	Bit 7	Bit 6	Bit 5	Bit 4	Bit 3	Bit 2	Bit 1	Bit 0
IDR	R/W	Control				Address			
		XCS	PME	FME	CHE				

Symbol	Bit	Description
XCS	7	A programmable bit which is routed to the XCS pin one time slot prior to the data to which it relates.
PME	6	A high enables the pattern mode; the lower 8 bits of the connection address (time slot and stream LSB) is routed to the time slot instead of data.
FME	5	A high enables the use of the alternate data buffer. (Refer to Appendix B for minimum and constant delay settings.)
CHE	4	Enables the time-slot connection; a low in this bit forces 3-state during the time slot.
Address	3—0	All 4 bits are used for the stream address of the desired data memory location.

After the second transfer is made, the entire 15 bits will be loaded into the connection memory; i.e., the second transfer triggers the actual memory access. Figure 22 shows how the connections are made from the perspective of the registers and memory contents.

If the user wishes to set up a pattern mode connection, then the first transfer is a full 8 bits (i.e., the pattern), rather than the 7-bit time-slot value. This pattern byte will be stored in the lowest 8 bits of the selected connection memory location. The pattern byte will be sent instead of a byte from local data memory during the output stream and time slot which corresponds to the connection memory location.

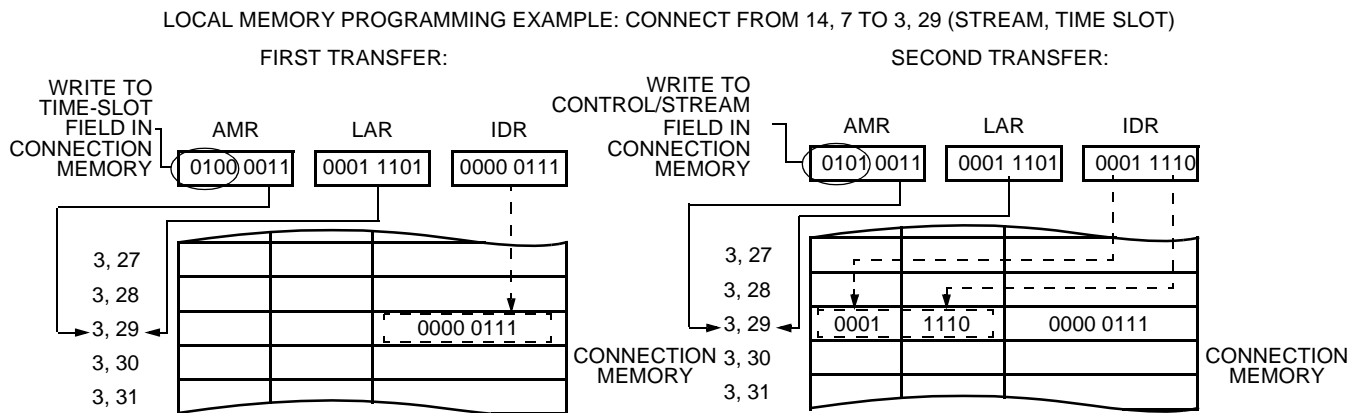

5-6115aF

Figure 22. Local-to-Local Connection Programming (T8100A, T8105 Only)

3 Using the TSI Devices (continued)

3.4 Using the LAR, AMR, and IDR for Connections (continued)

3.4.2 Setting Up H-Bus Connections

Table 71. IDR: Indirect Data Register, H-Bus Connections Only

Reg	R/W	Bit 7	Bit 6	Bit 5	Bit 4	Bit 3	Bit 2	Bit 1	Bit 0
IDR	—	Control			Address				
		R/W	PME	FME	—	—	—	—	—

Symbol	Bit	Description
R/W	7	Refers to the direction in the CAM data memory. A read sends data to the bus; a write loads data from the bus.
PME	6	Pattern mode enable, similar to above, except the tag byte is output instead of the lower address bits.
FME	5	Data buffer selection for setting delay type. (Refer to Appendix B for minimum and constant delay settings.)
Address	4—0	All 5 bits are used for the stream address of the desired data memory location.

The CAM blocks are 512 locations each (T8102, T8105 only) and the operations for the CAM blocks are selected by AMR (see Section 2.1.3 Address Mode Register and Section 2.3.2 CAM Operation and Commands). Since the block address is carried in the AMR, this reduces the number of bits that are necessary to establish a connection. Eleven (11) address bits, i.e., bits for stream and time-slot identification, the 8-bit tag (pointer to the H-bus data memory), and 3 control bits all need to be written into the selected CAM block for setting up a connection. (The empty bit is a status bit that is changed internally as a result of operations on the CAM.) Four* transfers, indirect writes through the IDR, are required to set up a connection in the CAM, though the method of transfer is different than with the local memory. Since a specific physical address is not always necessary, the CAM will automatically fill the first available slot. Thus, the LAR is not required for setting up the connection. (See the notes below.) The first transfer after programming the AMR requires that the 7 bits which identify the time-slot number (refer to Section 2.3.5 H-Bus Rate Selection and Connection Address Format for the proper format) be loaded into the IDR. The second transfer uses a similar field description for the IDR as presented for local connections [Section 3.4.1 Setting Up Local Connections (T8100A, T8105 Only) above]. The address field contains the stream number (5 bits), and the control field contains only 3 control bits.

The third transfer for CAM connection setup is the transfer of the lower 8 bits of the tag field. The tag is loaded into the IDR. The fourth transfer is the subrate control field and the TAG field MSB. The connection for the CAM is actually set up, (i.e., the memory access takes place) using a fifth write. It is an indirect write to the AMR (again through the IDR) which corresponds with the specific command and blocks the user requests. All CAM commands require that the IDR be loaded with the same command value as the AMR rather than a don't care or dummy value.

Notes: If an address is to be matched, such as the break connection command, then only the first two transfers are required. The tag is unnecessary for identifying a connection.

The LAR is only used to read or query a specific location (i.e., 0—511) in a particular CAM block. Refer to Section 2.1.3 Address Mode Register and Section 2.3.2 CAM Operation and Commands for details on these commands.

For the CAMs, pattern mode is a 1/2 connection. Only the intended output to the H-bus (or to the local pins) needs to be specified. The setup is the same as described above, four transfers to the holding registers followed by the make connection command to the appropriate CAM block. When the address is matched, the tag value (from the pipeline SRAM) will be sent as output to the bus[†].

* Four transfers are required for the T8105 and T8102. For the T8100A, if subrate is enabled, then four transfers are also required. If subrate is disabled, only three transfers are required and the T8100A follows the same programming model as the T8100.

† Two subsequent IDR reads are required to retrieve the 9-bit physical address for the T8105 and T8102. Only one IDR read is required to retrieve the 8-bit physical address for the T8100A.

3 Using the TSI Devices (continued)

3.4 Using the LAR, AMR, and IDR for Connections (continued)

3.4.2 Setting Up H-Bus Connections (continued)

Figure 23 illustrates how a CAM connection is made from the perspective of registers and the memory locations. Note that each half of the connection (i.e., the FROM and the TO) requires a separate setup, though each half will point to the same location in the H-bus data memory.

Following Figure 23, some simple programming examples are shown using pseudoassembler code. The local-to-local and H-bus-to-local switching examples from Figure 22 and Figure 23 are reused in code examples #2 and #3. The connections are referred to in stream, time-slot format.

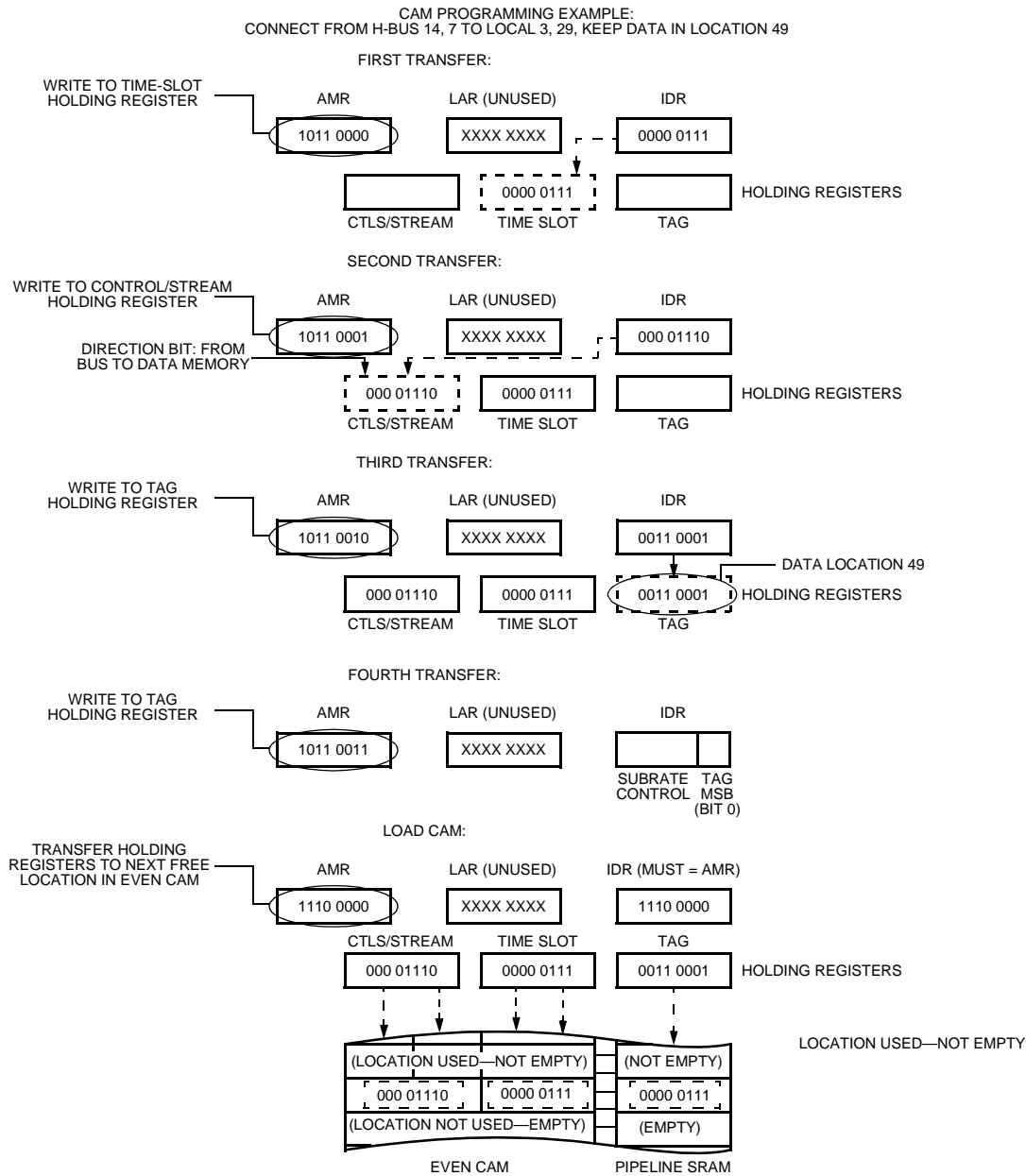

5-6116aF

A. First Half of Connection, H-Bus Side

Figure 23. CAM Programming, H-Bus-to-Local Connection

3 Using the TSI Devices (continued)

3.4 Using the LAR, AMR, and IDR for Connections (continued)

3.4.2 Setting Up H-Bus Connections (continued)

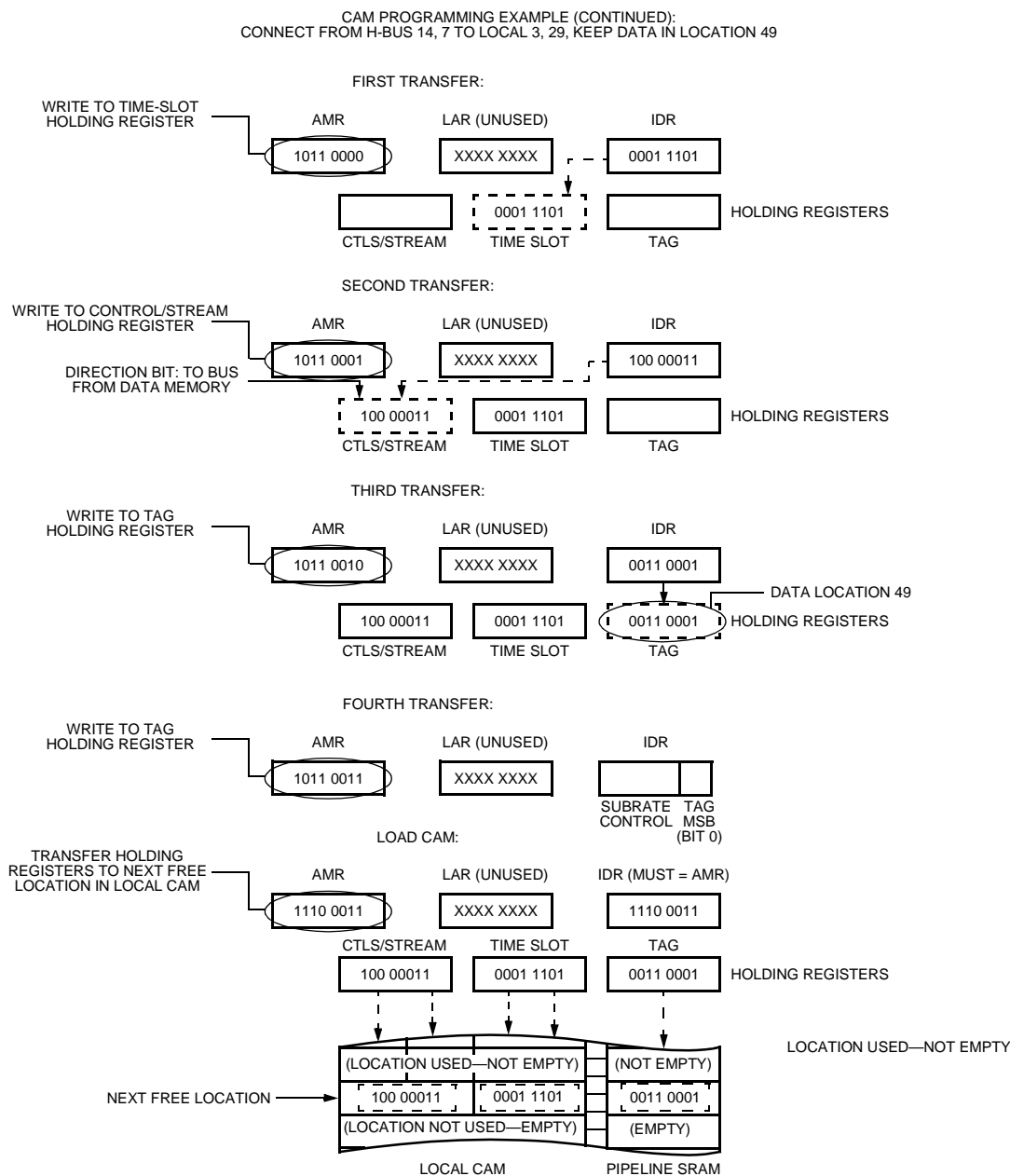

5-6117aF

B. Second Half of Connection, Local Side

Figure 23. CAM Programming, H-Bus-to-Local Connection (continued)

3 Using the TSI Devices (continued)

3.4 Using the LAR, AMR, and IDR for Connections (continued)

3.4.3 Programming Examples

```
;All programming examples included are in a pseudoassembler format.
;The basic commands used are the "move direct" and "move indirect."
;A move direct command is indicated by the letters "MD" followed by
;the register name, then the data. Similarly, a move indirect command
;is indicated by the letters "MI" followed by the register name, then by
;data or another register reference (the register may not be indirect).
;The semicolon delineates comments. Direct data is followed by the
;letter "h" for Hex and "b" for binary.

;*****EXAMPLE #1 - Set Up Clocks, Local Bus, H-Bus, and Framers
;
;*****Misc. Stuff
;
MD,AMR,00h           ;Define control space
                    ;all specific register names are equivalent
                    ;to the LAR addresses (from Table 11)
;
;
;*****Set up Clocks
                    ;**Main Clock Register
MD,IDR,0C2h         ;Load IDR with values for bit slider on, slave mode,
                    ;and synced to ECTF Bus A Clocks
MI,CKM,IDR          ;The data in IDR is moved into CKM via the LAR register.
;
;**NETREF Registers
MD,IDR,88h          ;Set up NETREF from Local Reference 0, 2.048 MHz bit clock
                    ;in, divided value
                    ;value out (i.e., 8 kHz), enable the DJAT connections
MI,CKN,IDR          ;Move the data to CKN
MD,IDR,0FFh         ;Set up NETREF divider with divide-by-256
MI,CKND,IDR         ;Move the data to CKND
;
;**Programmable Clocks
MD,IDR,26h          ;This selects the oscillator for the TCLKOUT, A Clock
                    ;outputs off, and
                    ;driving ECTF B Clocks
MI,CKP,IDR          ;Move the data
;
;**Clock Resources
MD,IDR,40h          ;Synced to bus so select Resource divider, x16 on PLL #1 &
                    ;x8 PLL #2, SC Clocks off
MI,CKR,IDR          ;Make it so
MD,IDR,01h          ;Set up Resource divider with divide-by-2 for 4 MHz signal
                    ;into PLL #1
MI,CKRD,IDR         ;Move the data to divider
;
```

3 Using the TSI Devices (continued)

3.4 Using the LAR, AMR, and IDR for Connections (continued)

3.4.3 Programming Examples (continued)

```

; **Secondary Controls (Fallback)
MD, IDR, 35h           ; Enable ECTF Fallback: Become the new A Clock master on A
                       ; Clock failure,
                       ; synchronizes to a bit clock on local reference 1, but
                       ; requires the main divider
                       ; with external input (assumes a CLAD is between the
                       ; divider and 4MHzIn).
MI, CKS, IDR          ; Move the data to CKS
MD, IDR, 0FFh         ; Set up Main divider with divide-by-256
MI, CKMD, IDR        ; Move the data to divider
                       ;

; **Local Clocks
MD, IDR, 0E4h         ; Local Selected Clock 3 gets inverted 8.192 MHz, LSC2 gets
                       ; 2.048 MHz
MI, CK32, IDR        ; Move it to CK32
MD, IDR, 80h         ; LSC1 is high & LSC0 is low
MI, CK10, IDR        ; Move it to CK10
                       ;

; *****Set up Local Streams
;
MD, IDR, 30h          ; 8 Streams at 8 Mbits/s
MI, LBS, IDR         ; Define input streams per IDR
                       ;

; *****Set up H Bus Streams
;
MD, IDR, 0AAh        ; Define H-Bus Streams 0 - 15 for 4 Mbits/s
MI, HSL, IDR         ; Do it
                       ;

MD, IDR, 0FFh        ; Define H-Bus Streams 16-31 for 8 Mbits/s
MI, HSH, IDR         ; Engage

; *****Set up Framers
;
MD, IDR, 00h         ; This sequence sets up Group A
MI, FRLA, IDR        ;           to start coincident
MI, FRLB, IDR        ;           with the Frame
MI, FRPH, IDR        ;           boundary and Group B
MD, IDR, 0F0h        ;           to start halfway through
MI, FRHA, IDR        ;           the Frame. The Groups
MD, IDR, 0F4h        ;           operate in normal framing mode
MI, FRHB, IDR        ;           at 8 Mbits/s and are Double Byte wide.
                       ; Note: FRPH sets up the correct routing.
;

; *****Connect the devices to the outside world
;
MD, MCR, 0Eh         ;           Enable H-Bus Streams & Clock, Local Streams,
                       ;           local
                       ;           Clocks including Framers
;

; *****END OF EXAMPLE #1

```

3 Using the TSI Devices (continued)

3.4 Using the LAR, AMR, and IDR for Connections (continued)

3.4.3 Programming Examples (continued)

```
*****EXAMPLE #2 - Setting up Local Connections (T8100A, T8105 only)
;
;       Use 8 Mbits/s rate set up from Example #1...
;       Send data FROM Stream/Time Slot 14, 7 TO Stream/Time Slot 3, 29.
;       To transfer data the local input 14, 7 to the local
;       output 3, 29 the following programming steps are required.
;
MD,LAR,1Dh           ;Set up lower address, i.e., Time Slot 29
MD,AMR,43h           ;           Set up upper address bits (Stream 3), and
;                       point to the
;                       the Time Slot field of the connection memory
MI,IDR,07h           ;Put a "7" in the Time Slot field of connection location
;                       3,29
;
;Syntactically, "MI,IDR,data" is a special case since IDR is not the final recipient
of the data
;
MD,AMR,53h           ;Maintain the same upper address, but get ready to load the
;                       remaining connection info (upper bits +
;                       control)
MI,IDR,0001_1110b    ;This decodes as follows: XCS bit low, pattern mode off
;                       (not set), frame bit low, time slot enabled,
;                       and stream = 1110b (14)
;
*****END OF EXAMPLE #2
*****EXAMPLE #3 - Setting up H-Bus Connections, No Substrate
;
; Use rate set up from Example #1...
; Send data from Stream 14/Time Slot 7 of the H.100 bus to Stream 3/Time Slot 29
; on the Local side. The data is coming in at 4 Mbits/s from E-CAM, and is sent
; out at 8 Mbits/s to through L-CAM. We're using Data Memory location 49 to hold
; the actual data. LAR is not used for the CAM connection setups; it is used for
; reading specific CAM locations or writing and reading the associated Data
; Memory Locations.
;
;*****Set up the "from" connection
;
MD,AMR,0B0h           ;Point to the Time-Slot holding register
MI,IDR,07h           ;This is the Time-Slot value (7) for the H-Bus address
MD,AMR,0B1h           ;Point to the upper bits of the connection
MI,IDR,000_01110b    ;Set up a write into data memory from ECTF bus,
;                       disable pattern mode, minimum delay,
;                       and set stream number equal to 01110b (14).
MD,AMR,0B2h           ;Point to tag field
MI,IDR,31h           ;Use location 49 of the associated Data RAM to store the data
MD,AMR,0B3h           ;Point to the substrate control and TAG MSB field;
MI,IDR,00h           ;MSB of location 49 is 0;
;
MD,AMR,0E0h           ;Write to next free location in the Even CAM
MI,IDR,0E0h           ;The command is executed with the indirect to IDR which
;                       uses the same command value as in the AMR.
```

3 Using the TSI Devices (continued)

3.4 Using the LAR, AMR, and IDR for Connections (continued)

3.4.3 Programming Examples (continued)

```

;
; **Optional: Test CAM Busy bit**
TEST:
MD,ACC,MCR           ;Move MCR contents into (host's) accumulator (for example)
AND,01h             ;Logical AND, i.e., mask off all but LSB of the MCR register
JNZ TEST            ;If the LSB is zero (not busy), continue, else jump back and
                    ;retest
;
CONTINUE:
;
; *****Set up the "to" connection
;
MD,AMR,0B0h         ;Point to the Time-Slot holding register
MI,IDR,1Dh          ;This is the Time-Slot value (29) for the Local address
MD,AMR,0B1h         ;Point to the upper bits of the connection
MI,IDR,100_00011b  ;Set up a read from data memory to Local pins,
                    ;                disable pattern mode, minimum delay, and set
                    ;                stream number equal to 00011b (3).
MD,AMR,0B2h         ;Point to tag field
MI,IDR,31h          ;Use location 49 of the associated Data RAM to store the data
;
MD,AMR,0B3h;
MI,IDR,00h;
MD,AMR,0E3h         ;Write to next free location in the Local CAM
MI,IDR,0E3h         ;The command is executed with the indirect to IDR
;
; **CAM Busy bit can be tested here**
;
;
; *****END OF EXAMPLE #3

```

3.4.4 Miscellaneous Commands

These commands (i.e., 0x70, 0xF8, all reset commands in the AMR register) require two writes: first the value is written to the AMR register; then the same value is written to the IDR register. After writing to the IDR register, the command will be executed.

4 Electrical Characteristics

4.1 Absolute Maximum Ratings

Stresses in excess of the absolute maximum ratings can cause permanent damage to the device. These are absolute stress ratings only. Functional operation of the device is not implied at these or any other conditions in excess of those given in the operational sections of this data sheet. Exposure to absolute maximum ratings for extended periods can adversely affect device reliability.

Description	Symbol	Min	Max	Unit
Supply Voltage	V_{DD}	—	3.6	V
XTALIN and XTALOUT Pins	—	V_{SS}	V_{DD}	V
Voltage Applied to I/O Pins	—	$V_{SS} - 0.5$	$V_{DD} + 3.4$	V
Operating Temperature:				
208-pin SQFP	—	0	70	°C
217-ball BGA	—	-40	85	°C
Storage Temperature	T_{stg}	-55	125	°C

4.2 Handling Precautions

Although protection circuitry has been designed into this device, proper precautions should be taken to avoid exposure to electrostatic discharge (ESD) during handling and mounting. Lucent employs a human-body model (HBM) and a charged-device model (CDM) for ESD-susceptibility testing and protection design evaluation. ESD voltage thresholds are dependent on the circuit parameters used to define the model. No industry-wide standard has been adopted for CDM. However, a standard HBM (resistance = 1500 Ω , capacitance = 100 pF) is widely used and, therefore, can be used for comparison purposes:

HBM ESD Threshold Voltage	
Device	Rating
T8100A, T8102, T8105	2500 V

4 Electrical Characteristics (continued)

4.3 Crystal Information

Table 72. Crystal Specifications

The devices require a 16.384 MHz clock source. To supply this, a 16.384 MHz crystal can be connected between the XTALIN and XTALOUT pins. External 18 pF, 5% capacitors must be connected from XTALIN and XTALOUT to V_{SS}. Crystal specifications are shown below. The ±32 ppm tolerance is the suggested value if the oscillator is used as the clocking source while mastering the bus. Otherwise, a crystal with a lesser tolerance can be used.

Parameter	Value
Frequency	16.384 MHz
Oscillation Mode	Fundamental, Parallel Resonant
Effective Series Resistance	40 Ω maximum
Load Capacitance	14 pF
Shunt Capacitance	7 pF maximum
Frequency Tolerance and Stability	32 ppm

5-6390(F)

Table 73. Use of an Oscillator as an Alternative to Using a Crystal

XTALIN can be driven by a CMOS signal instead of a crystal. XTALIN and XTALOUT are not 5 V tolerant. The oscillator must meet the requirements shown below.

Parameter	Value
Frequency	16.384 MHz
Maximum Rise or Fall Time	10 ns, 10% to 90% V _{DD}
Minimum Pulse Width	Low
	High
	20 ns 20 ns

4.4 Reset Pulse

Parameter	Min	Max	Unit
RESET Minimum Pulse Width	61	—	ns

4.5 Thermal Considerations

4.5.1 Thermal Considerations for the 208 SQFP

Parameter	Construction Details	Body Size (mm sq.)	Thermal Numbers			Paddle Size (mil sq.)	Max. Power (Natural Convection) (Watts)
			Theta-JA (°C/W)				
			Natural Convection	200 fpm	500 fpm		
4-Layer JEDEC Test Board	Cu L.F.	20	26.5	23	21	433	2.1

4.5.2 Thermal Considerations for the 217 PBGA

Parameter	Body Size (mm sq.)	Array Details	Ball Pitch (mm)	Number of Layers	Thermal Numbers			Max. Power (Natural Convection) (Watts)
					Theta-JA (°C/W)			
					Natural Convection	200 fpm	500 fpm	
4-Layer JEDEC Test Board	23	Peripheral + T.A.	1.27	2	32.5	29	27.5	1.7

4 Electrical Characteristics (continued)

4.6 dc Electrical Characteristics, H-Bus (ECTF H.100 Spec., Rev. 1.0)

4.6.1 Electrical Drive Specifications—CT_C8 and /CT_FRAME

Table 74. Electrical Drive Specifications—CT_C8 and /CT_FRAME

$V_{DD} = 3.3\text{ V}$ and $V_{SS} = 0.0\text{ V}$ unless otherwise specified.

Parameter	Symbol	Condition	Min	Max	Unit
Output High Voltage	V_{OH}	$I_{OUT} = -24\text{ mA}$	2.4	3.3	V
Output Low Voltage	V_{OL}	$I_{OUT} = 24\text{ mA}$	-0.25	0.4	V
Positive-going Threshold	V_{t+}	—	1.2	2.0	V
Negative-going Threshold	V_{t-}	—	0.6	1.6	V
Hysteresis ($V_{t+} - V_{t-}$)	V_{HYS}	—	0.4	—	V
Input Pin Capacitance	C_{IN}	—	—	10	pF

PCI-compliant data line I/O cells are used for the CT bus data lines. (See PCI Specification, Rev. 2.1, Chapter 4.)

/C16, /C4, C2, SCLK, $\overline{\text{SCLKX2}}$, and /FR_COMP all use the same driver/receiver pairs as those specified for the CT_C8 and /CT_FRAME signals, though this is not explicitly stated as a part of the H.100 Specification.

4.7 dc Electrical Characteristics, All Other Pins

Table 75. dc Electrical Characteristics, All Other Pins

$V_{DD} = 3.3\text{ V}$ and $V_{SS} = 0.0\text{ V}$ unless otherwise specified.

Description	Symbol	Condition	Min	Typ	Max	Unit
Supply Current	I_{DD}	—	—	175*	275*	mA
Supply Voltage	V_{DD}	—	3.0	—	3.6	V
Input High Voltage	V_{IH}	—	2.0	—	—	V
Input Low Voltage	V_{IL}	—	—	—	0.8	V
Input Current	I_I	—	—	—	1	μA
Input Capacitance (input only)	C_I	—	—	—	5	pF
Input Capacitance (I/O pins)	C_{IO}	—	—	—	10	pF
Leakage Current (3-state)	I_{LEAK}	—	—	—	10	μA
Input Clamp Voltage	V_C	—	—	—	-1.0	V
Output High Voltage	V_{OH}	—	2.4	—	—	V
Output Low Voltage	V_{OL}	—	—	—	0.4	V
Output Short-circuit Current	I_{OS}	V_{OH} tied to GND	—	—	100	mA

* Circuit simulation indicates a typical current of 175 mA and a worst-case current of 275 mA. This parameter is not tested in production.

4 Electrical Characteristics (continued)

4.8 H-Bus Timing (Extract from H.100 Spec., Rev. 1.0)

4.8.1 Clock Alignment

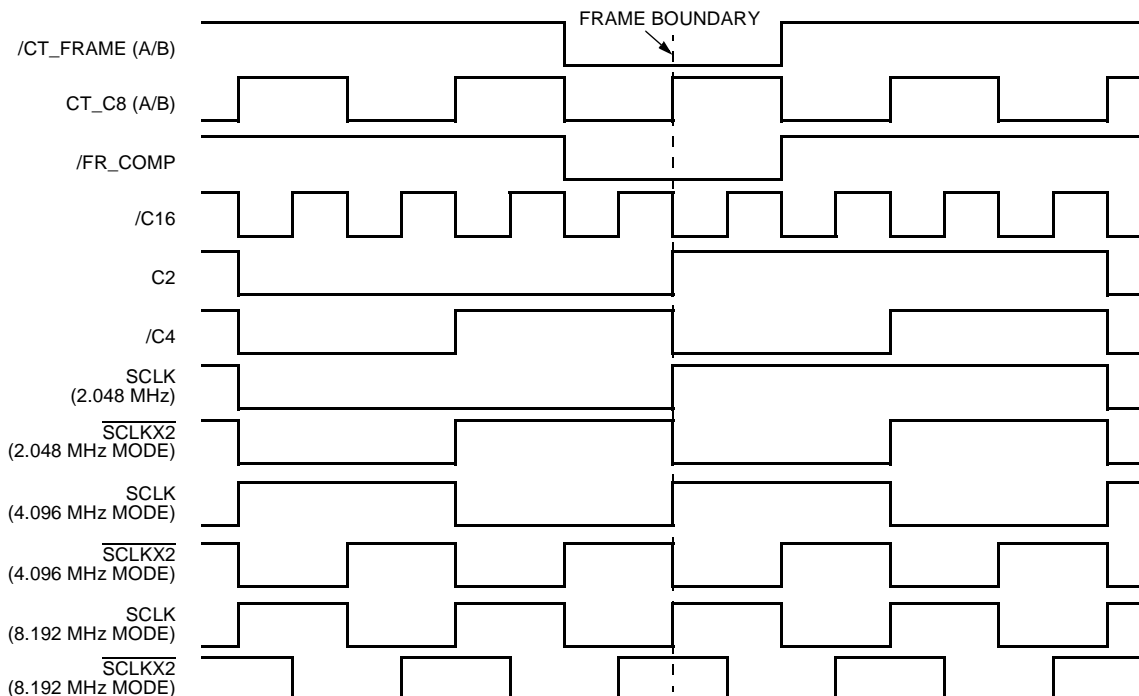

5-6119F

Figure 24. Clock Alignment

4.8.2 Frame Diagram

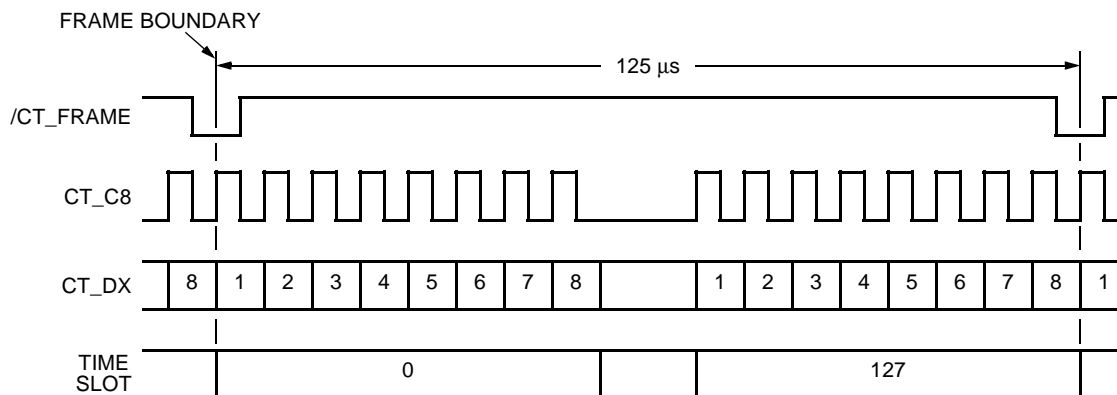

5-6120F

Note: Bit 1 is the MSB. Bit 8 is the LSB. MSB is always transmitted first in all transfers.

Figure 25. Frame Diagram

4 Electrical Characteristics (continued)

4.8 H-Bus Timing (Extract from H.100 Spec., Rev. 1.0) (continued)

4.8.3 Detailed Timing Diagram

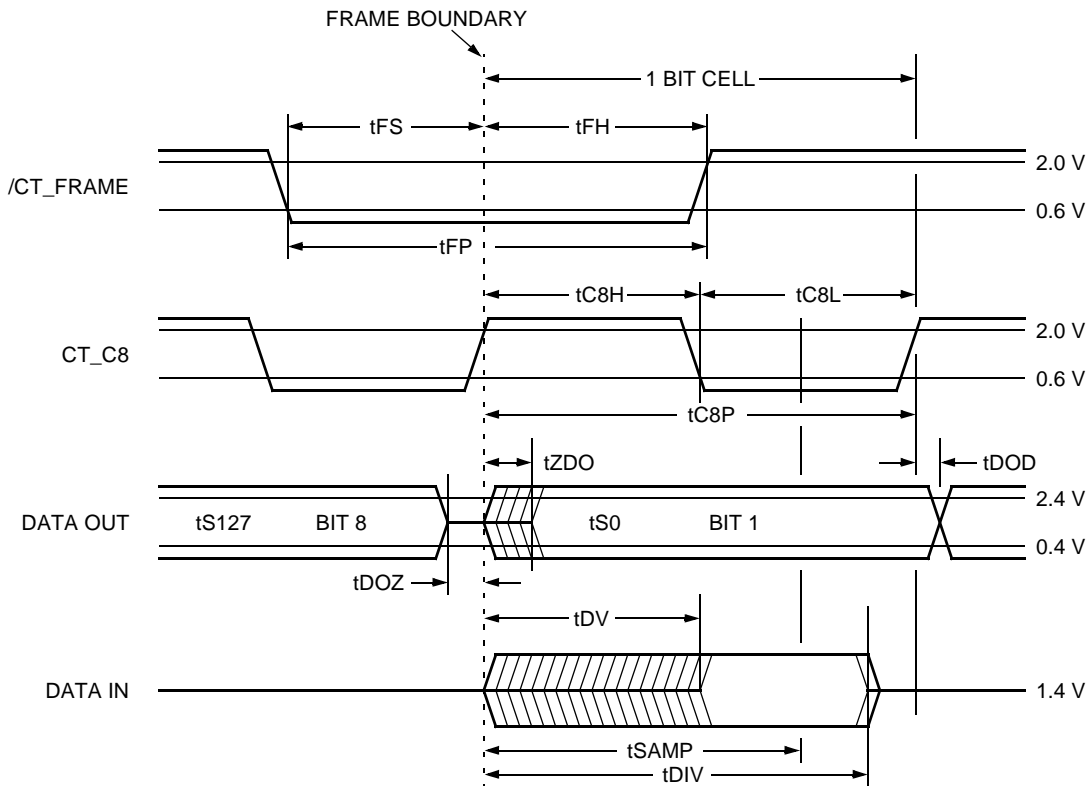

5-6121F

Figure 26. Detailed Timing Diagram

4 Electrical Characteristics (continued)

4.8 H-Bus Timing (Extract from H.100 Spec., Rev. 1.0) (continued)

4.8.4 ac Electrical Characteristics, Timing, H-Bus (H.100 Spec., Rev. 1.0)

Table 76. ac Electrical Characteristics, Timing, H-Bus (H.100 Spec., Rev. 1.0)

Symbol	Parameter	Min	Typ	Max	Unit	Notes
—	Clock Edge Rate (all clocks)	0.25	—	2	V/ns	1, 2, 4
tC8P	Clock CT_C8 Period	122.066 – Φ	—	122.074 + Φ	ns	2, 4, 5
tC8H	Clock CT_C8 High Time	49 – Φ	—	73 + Φ	ns	2, 4, 6
tC8L	Clock CT_C8 Low Time	49 – Φ	—	73 + Φ	ns	2, 4, 6
tSAMP	Data Sample Point	—	90	—	ns	2, 4, 9
tDOZ	Data Output to HiZ Time	–20	—	0	ns	2, 3, 4, 7, 11
tZDO	Data HiZ to Output Time	0	—	22	ns	2, 3, 4, 7, 11
tDOD	Data Output Delay Time	0	—	22	ns	2, 3, 4, 7
tDV	Data Valid Time	0	—	69	ns	2, 3, 4, 8, 10
tDIV	Data Invalid Time	102	—	112	ns	2, 4
tFP	/CT_FRAME Width	90	122	180	ns	2, 4
tFS	/CT_FRAME Setup Time	45	—	90	ns	2, 4
tFH	/CT_FRAME Hold Time	45	—	90	ns	2, 4
Φ	Phase Correction	0	—	10	ns	12

- The rise and fall times are determined by the edge rate in V/ns. A maximum edge rate is the fastest rate at which a clock transitions. CT_NETREF has a separate requirement. (See Section 2.5 Clocking Section.)
- Measuring conditions, data lines: VTH (threshold voltage) = 1.4 V, VHI (test high voltage) = 2.4 V, VLO (test low voltage) = 0.4 V, input signal edge rate = 1 V/ns measuring conditions, clock and frame lines: Vt+ (test high voltage) = 2.0 V, Vt– (test low voltage) = 0.6 V, input signal edge rate = 1 V/ns.
- Test load—200 pF.
- When RESET is active, every output driver is 3-stated.
- tC8P minimum and maximum are under free-run conditions assuming ± 32 ppm clock accuracy.
- Noncumulative, tC8P requirements still need to be met.
- Measured at the transmitter.
- Measured at the receiver.
- For reference only.
- tDV = maximum clock cable delay + maximum data cable delay + maximum data HiZ to output time = 12 ns + 35 ns + 22 ns = 69 ns. Maximum clock cable delay and maximum data cable delay are worst-case numbers based on electrical simulation.
- tDOZ and tZDO apply at every time-slot boundary.
- F (phase correction) results from PLL timing corrections.

4 Electrical Characteristics (continued)

4.8 H-Bus Timing (Extract from H.100 Spec., Rev. 1.0) (continued)

4.8.5 Detailed Clock Skew Diagram

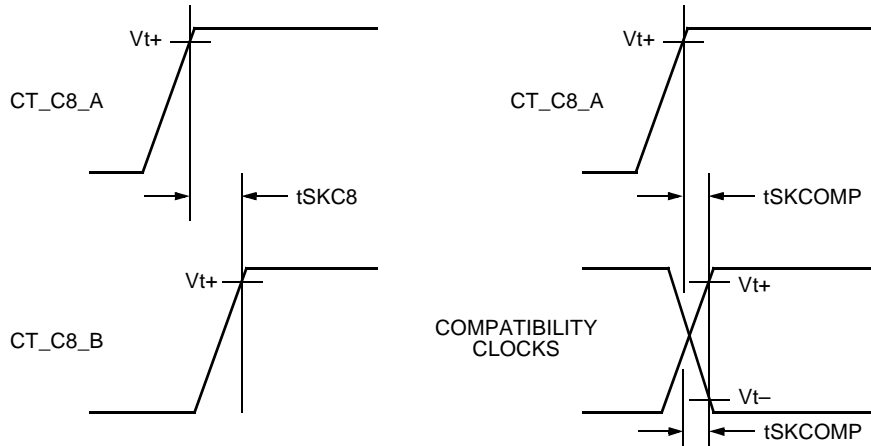

5-6122F

Figure 27. Detailed Clock Skew Diagram

4.8.6 ac Electrical Characteristics, Skew Timing, H-Bus (H.100 Spec., Rev. 1.0)

Table 77. ac Electrical Characteristics, Skew Timing, H-Bus (H.100 Spec., Rev. 1.0)

Symbol	Parameter	Min	Typ	Max	Unit	Notes
tSKC8	Maximum Skew Between CT_C8 A and B	—	—	$\pm 10, \pm \Phi$	ns	1, 2, 3, 4
tSKCOMP	Maximum Skew Between CT_C8_A and Any Compatibility Clock	—	—	± 5	ns	1
—	Maximum Skew Between CT_C8_A and L_SCx Clock	—	—	± 2	ns	1

1. Test load—50 pF.
2. Assumes A and B masters in adjacent slots.
3. When static skew is 10 ns and, in the same clock cycle, each clock performs a 10 ns phase correction in opposite directions, a maximum skew of 30 ns will occur during that clock cycle.
4. Meeting the skew requirements in Table 10 and the requirements of Section 2.3 H-Bus Section could require the PLLs generating CT_C8 to have different time constants when acting as primary and secondary clock masters.

4 Electrical Characteristics (continued)

4.8 H-Bus Timing (Extract from H.100 Spec., Rev. 1.0) (continued)

4.8.7 Reset and Power On

Table 78. Reset and Power On

Symbol	Parameter	Min	Typ	Max	Unit
tRD	Output Float Delay from Reset Active	—	—	1	μs
tRS	Reset Active from Power Good	—	5	—	μs

4.9 ac Electrical Characteristics, Local Streams, and Frames

Table 79. ac Electrical Characteristics, Local Streams, and Frames

Symbol	Description	Condition	Min	Max	Unit
tPD	Data Propagation Delay	Load = 50 pF	0	20	ns
tS	Data Setup Time	—	10	—	ns
tH	Data Hold Time	—	5	—	ns
tOFF	Data 3-state Off Time	—	—	20	ns
tD0	Data Bit 0 3-state	—	-20	0	ns

Table 80. L_SC[3:0] and Frame Group Rise and Fall Time

Description	Min	Typ	Max	Unit*
L_SCx Rise Time	—	—	5	ns
L_SCx Fall Time	—	—	4	ns
Frame Group Rise Time	—	—	3	ns
Frame Group Fall Time	—	—	3	ns

* Worst-case loading of 50 pF on all outputs except CT_D[31:0]. CT_D[31:0] drives 200 pF.

4 Electrical Characteristics (continued)

4.9 ac Electrical Characteristics, Local Streams, and Frames (continued)

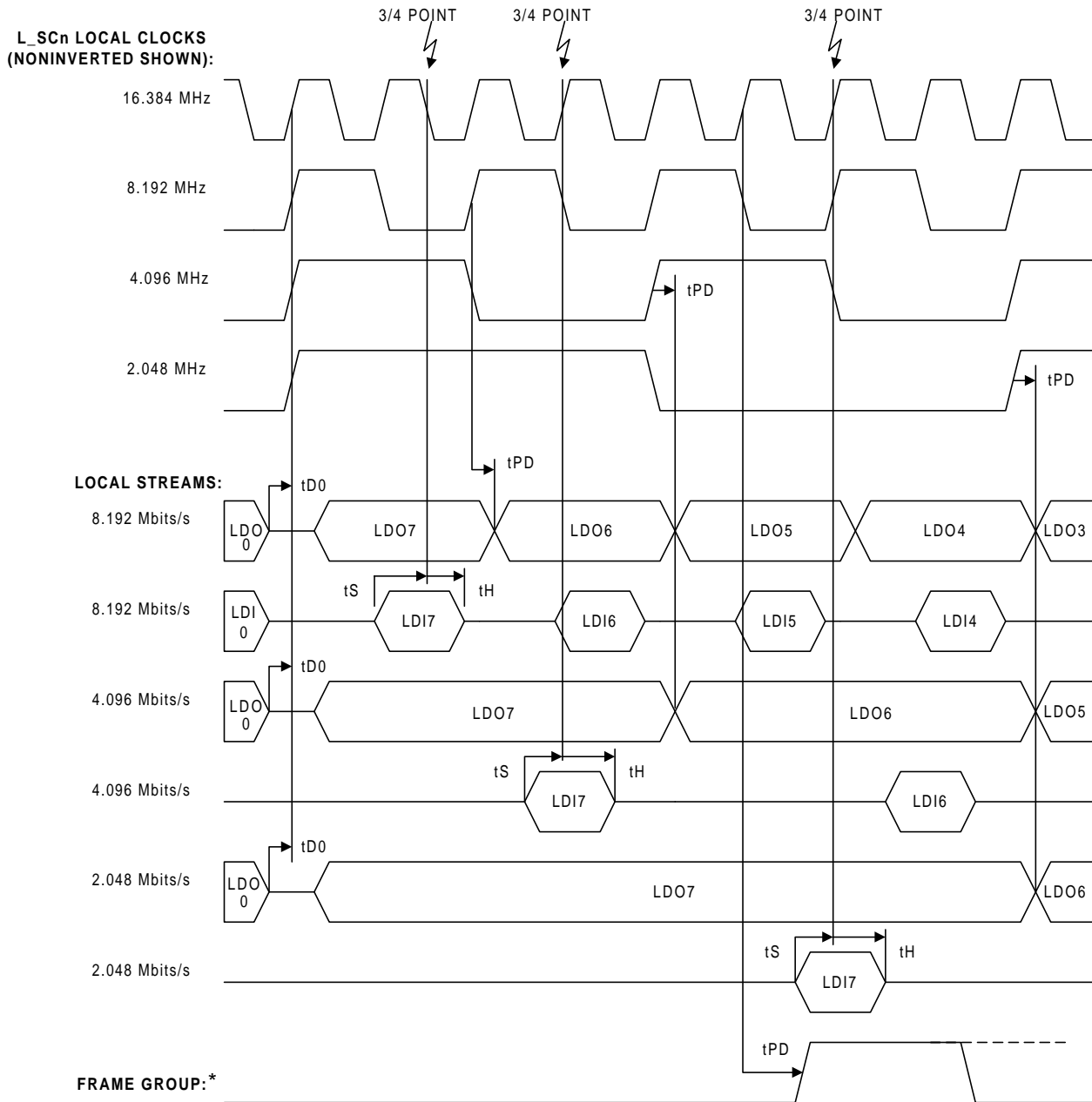

* Frame group is shown with an offset of four (4).

Note: LDO7 is the MSB, LDO0 is the LSB. MSB is always transmitted first in all transfers.

Figure 28. ac Electrical Characteristics, Local Streams, and Frames

4 Electrical Characteristics (continued)

4.10 ac Electrical Characteristics, Microprocessor Timing

4.10.1 Microprocessor Access *Intel* Multiplexed Write and Read Cycles

For *Intel* write and read cycles, when RDY is low, wait-states are inserted. RDY is brought high when tIACC is met. This is true for both read and write cycles.

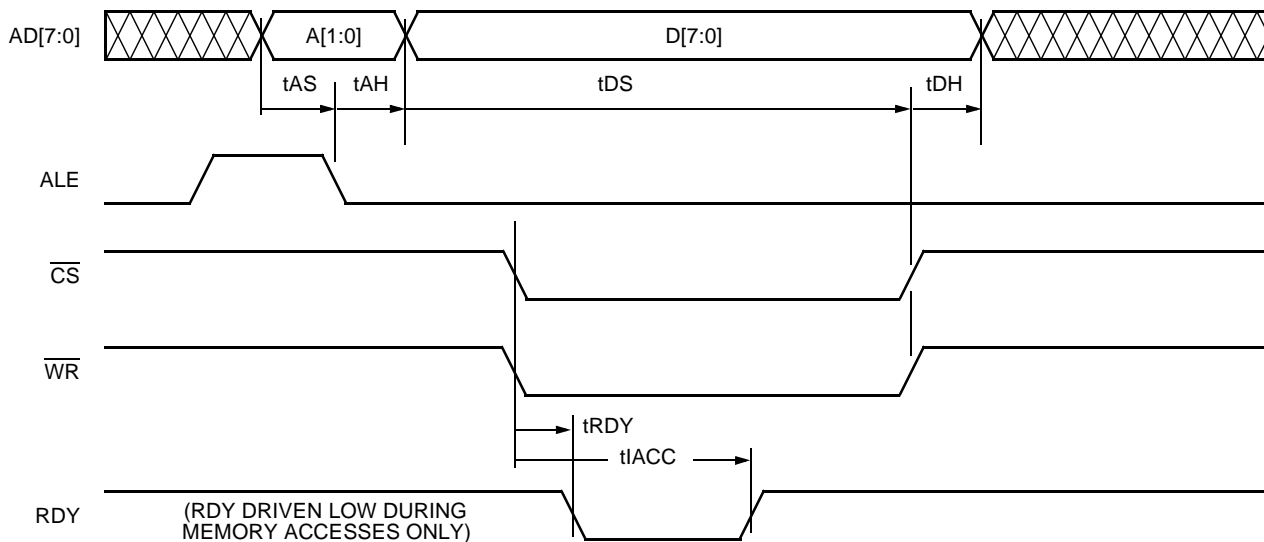

5-6124.bF

Figure 29. Microprocessor Access *Intel* Multiplexed Write Cycle

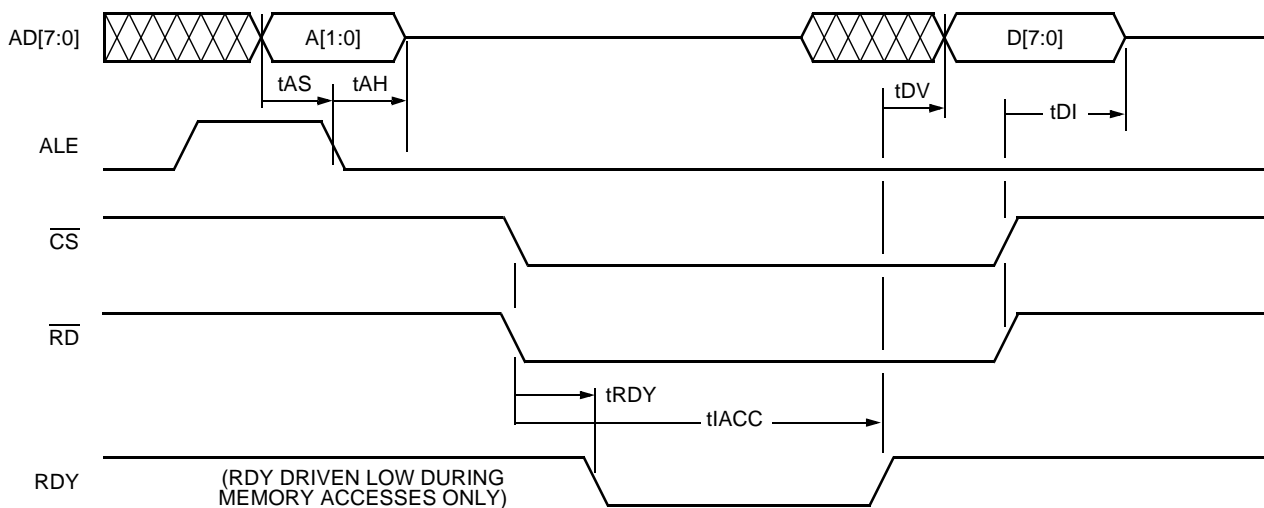

5-6125.bF

Figure 30. Microprocessor Access *Intel* Multiplexed Read Cycle

4 Electrical Characteristics (continued)

4.10 ac Electrical Characteristics, Microprocessor Timing (continued)

4.10.2 Microprocessor Access *Motorola* Write and Read Cycles

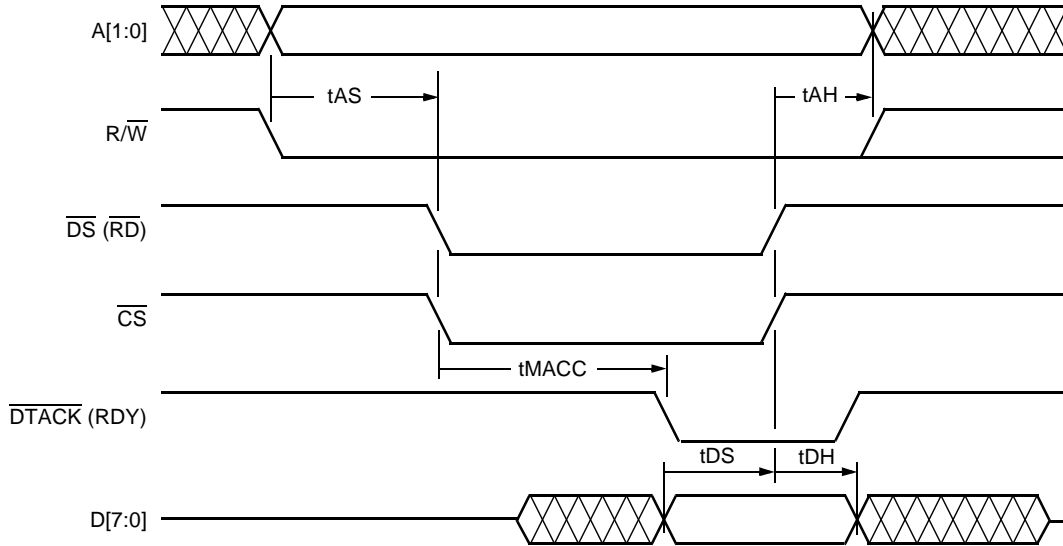

5-6126.cF

Figure 31. Microprocessor Access *Motorola* Write Cycle

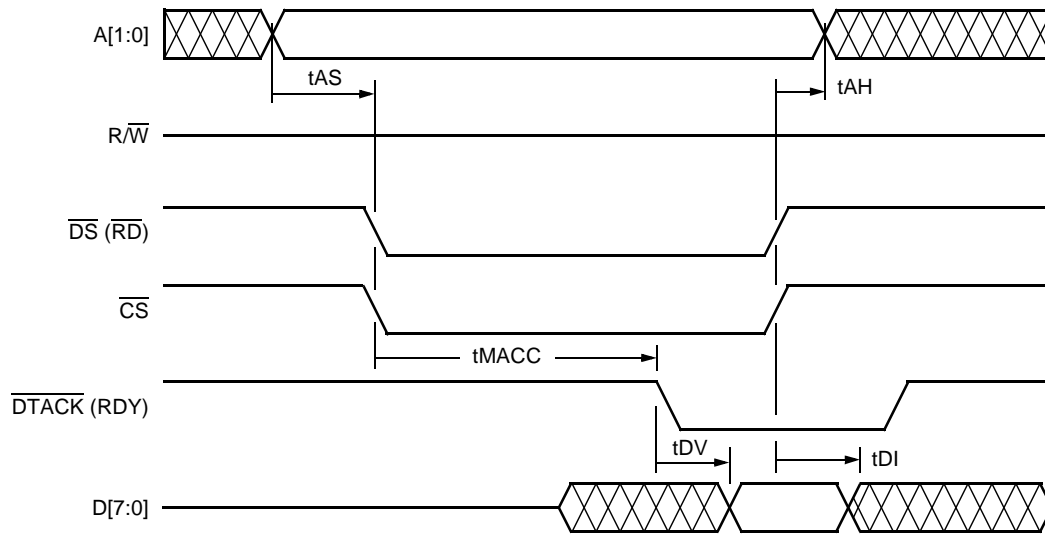

5-6127.bF

Figure 32. Microprocessor Access *Motorola* Read Cycle

4 Electrical Characteristics (continued)

4.10 ac Electrical Characteristics, Microprocessor Timing (continued)

4.10.3 Microprocessor Access *Intel* Demultiplexed Write and Read Cycles

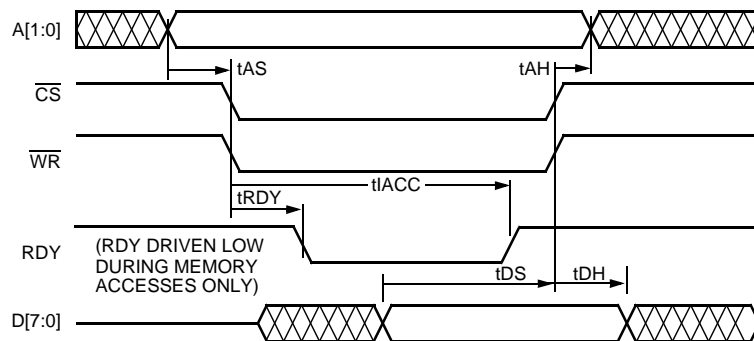

5-6128.cF

Figure 33. Microprocessor Access *Intel* Demultiplexed Write Cycle

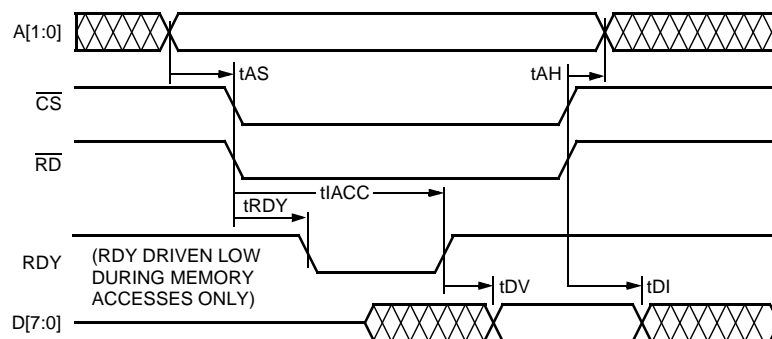

5-6128.bF

Figure 34. Microprocessor Access *Intel* Demultiplexed Read Cycle

Table 81. Microprocessor Access Timing

(See Figures 29 through 34.)

Symbol	Description	Condition	Min	Max	Unit
tAS	Address Setup Time	Load = 100 pF	7	—	ns
tAH	Address Hold Time	—	0	—	ns
tDV	Data Valid	—	—	13	ns
tDI	Data Invalid	—	0	11	ns
tRDY	Active to Ready Low (<i>Intel</i>)	Memory Access	—	14	ns
tIACC	Active to Ready High (<i>Intel</i>)	Memory Access	145	255	ns
tMACC	Active to \overline{DTACK} Low (<i>Motorola</i>)	Register Access Memory Access	— 130	14 255	ns
tDS	Data Setup Time	—	8	—	ns
tDH	Data Hold Time	—	0	—	ns

5 Outline Diagrams

5.1 208-Pin Square Quad Flat Package (SQFP)

Dimensions are in millimeters.

Note: The dimensions in this outline diagram are intended for informational purposes only. For detailed schematics to assist your design efforts, please contact your Lucent Technologies Microelectronics Group Account Manager.

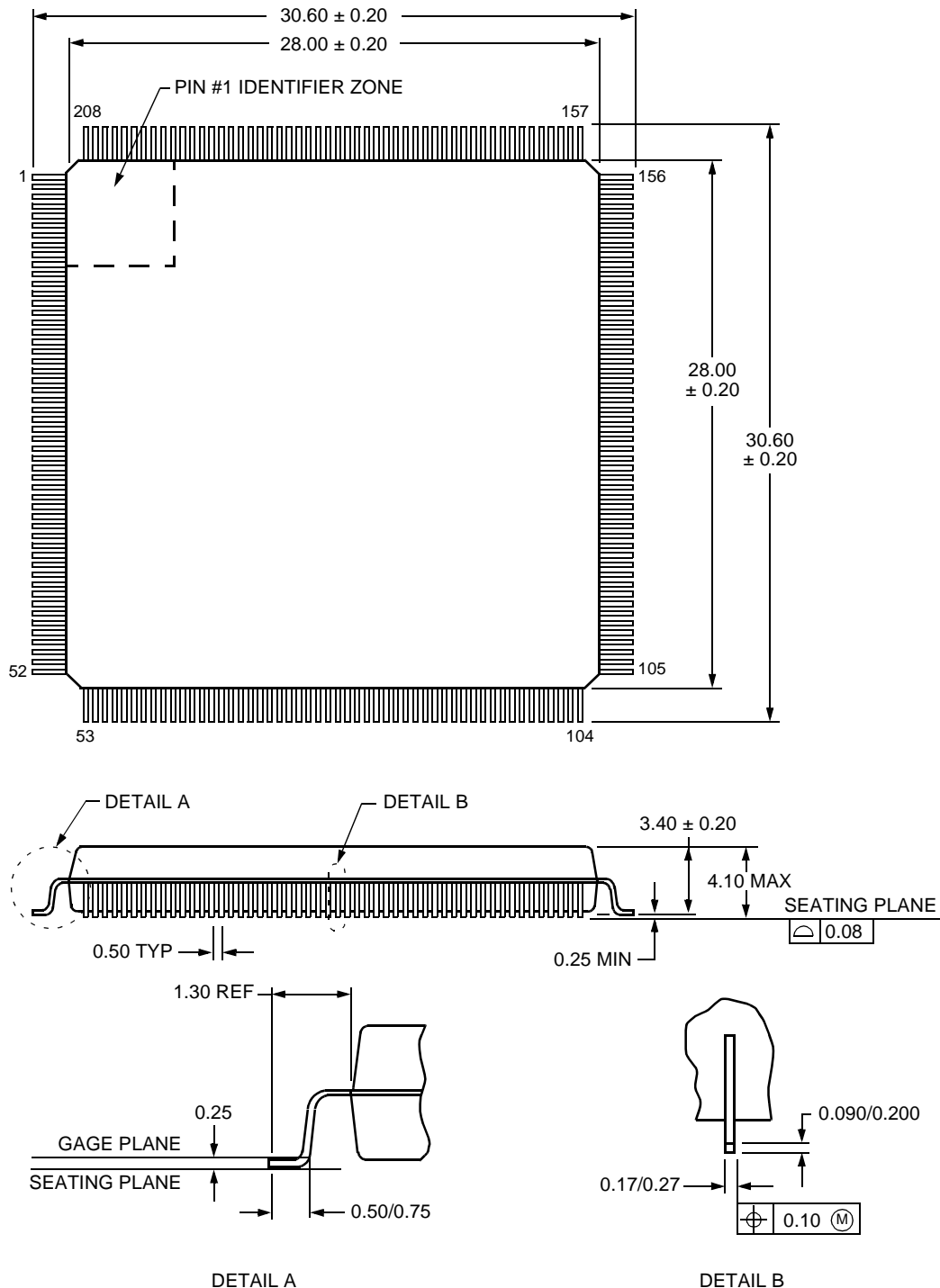

5 Outline Diagrams (continued)

5.2 217-Ball Plastic Ball Grid Array (PBGA)

Dimensions are in millimeters.

Note: The dimensions in this outline diagram are intended for informational purposes only. For detailed schematics to assist your design efforts, please contact your Lucent Technologies Microelectronics Group Account Manager.

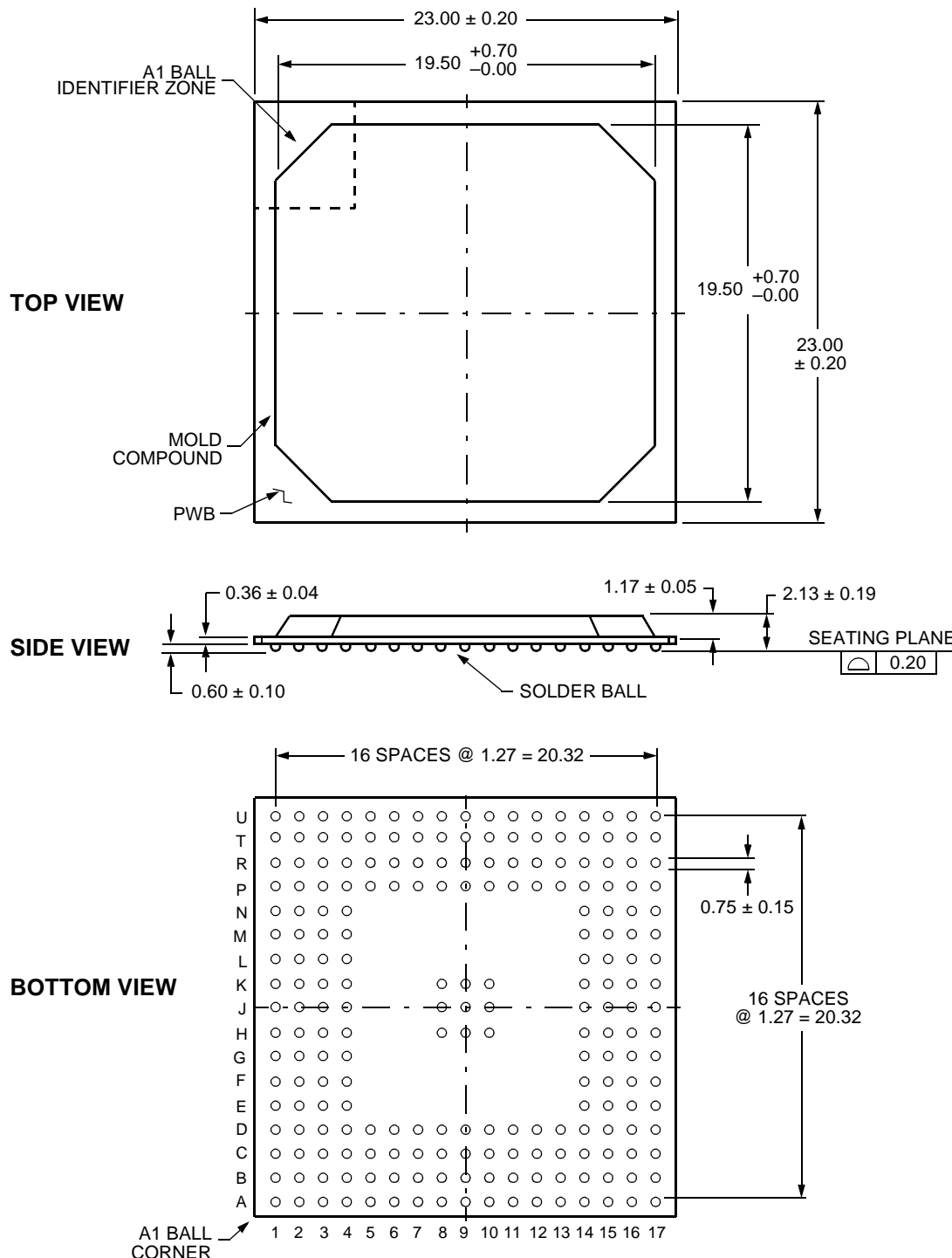

6 Ordering Information

Version 1 and 2		
Device Part Number	Package	Comcode
T8100A- - -SC-DB	208-Pin SQFP	108296146
T8100A- - -BAL-DB	217-Ball PBGA	108296138
T8102- - -SC-DB	208-Pin SQFP	108296161
T8102- - -BAL-DB	217-Ball PBGA	108296153
T8105- - -SC-DB	208-Pin SQFP	108296187
T8105- - -BAL-DB	217-Ball PBGA	108296179

Version 3		
Device Part Number	Package	Comcode
T8105- - -BAL3-BB	217-Ball PBGA	108553397
T8105- - -SC3-DB	208-Pin SQFP	108553561
T8102- - -SC3-DB	208-Pin SQFP	108553587
T8102- - -BAL3-DB	217-Ball PBGA	108553579
T8100A- -BAL3-DB	217-Ball PBGA	108553595
T8100A- -SC3-DB	208-Pin SQFP	108553603

Appendix A. Application of Clock Modes

In the diagrams that follow, four clock modes are illustrated using Figure 16, the clocking diagram, as the basis of each illustration. The key signal paths are shown in solid lines, and unused paths with narrow dashes. Two examples also indicate fallback paths. A register profile (programming values) for all four examples is on the last page of the appendix.

Figure 35 shows the devices in bus master operation, so they must link to either an 8 kHz recovered frame reference or a 2.048 MHz recovered bit clock reference from the E1 framers. In addition, the devices can provide one of the basic resource clocks to run the framers. In this case, the TCLKOUT is selecting the device's 16.384 MHz oscillator. The framers are returning a 2.048 MHz bit clock which is selected through the clock selector. It is not divided, so the main divider is bypassed (divide-by-1), the clock is smoothed through an external DJAT, and the smooth 2.048 MHz signal is routed to PLL #1 through the clock resource selector. PLL #1 multiplies the 2.048 MHz input up to 65.536 MHz which, in turn, runs the rest of each device, all bus clocks, and the local clocks (if desired). If the devices are not providing NETREF generation, then the NETREF from the bus is routed to the local clocks via the NETREF internal/external selector. Since the NETREF generation resources are not needed here, the TODJAT and FROMDJAT pins are free for use with the general-purpose register as bits GP6 and GP7, respectively.

Figure 36 shows the T1 version of a bus master. In this scenario, a 1.544 MHz recovered bit clock from the framers is routed to a multiclock adapter (with built-in jitter attenuation) which produces smooth 4.096 MHz and 3.088 MHz outputs. The 4.096 MHz output is routed up to PLL #1 for a times-16 rate multiplication to 65.536 MHz. This drives the bus clocks and the local clocks. The smooth 3.088 MHz is also rate multiplied times 8. This produces a 24.704 MHz clock. This is divided back down to produce a smooth 12.352 MHz which is fed back to the framers. (PLL outputs produce one tightly bound edge and one with significant phase jitter. Dividing a higher-frequency signal based on its clean edge produces a lower frequency with two clean edges.)

Figure 37 shows an H-MVIP slave arrangement for E1. In this example, the C16 differential clocks provide the main source for PLL #1. The 16.384 MHz signal is divided down to 4.096 MHz and then rate multiplied up to 65.536 MHz for driving the rest of each device. The frame sync for the state machines is derived from the /FRAME and C16 inputs as well as the state information provided by C2 and /C4.

Note: The bit slider is enabled for a smooth phase alignment between the internal frame and the frame sync.

The bus clocks are not driven, but the local clocks are available. A path for NETREF is shown as well, also based on a 2.048 MHz input. The signal is smoothed and then divided down to an 8 kHz signal via the NETREF divider. The internal oscillator is again chosen for routing to the framers via TCLKOUT.

Figure 38 shows an H-MVIP slave for T1. This is identical to the E1 case with regard to slaving, and a NETREF path is illustrated in this example, too. The NETREF divider has been changed to accommodate the 1.544 MHz bit clock rate. The primary difference is the use of the C16 clock through the main divider to generate a 2.048 MHz signal which can be routed off-chip and adapted to a 1.544 MHz signal using an external device. The 1.544 MHz signal is returned to each device via the 3MHzIN for rate multiplication up to 24.704 MHz and then division to a clean 12.352 MHz signal which is routed to the framers via TCLKOUT.

Appendix A. Application of Clock Modes (continued)

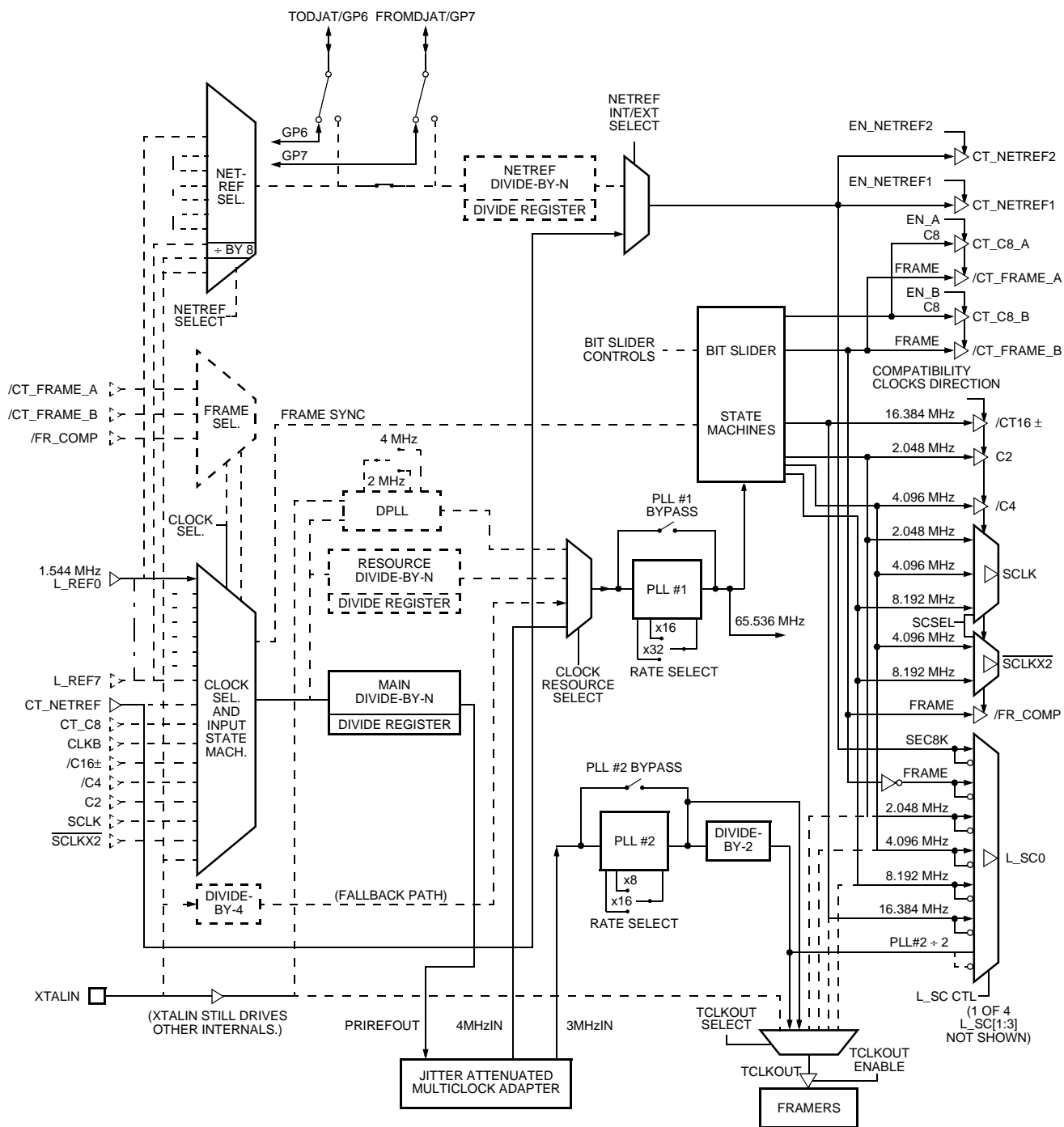

5-6130bF

Figure 36. T1, CT Bus Master, Compatibility Clock Master, Clock Source = 1.544 MHz from Trunk

Appendix A. Application of Clock Modes (continued)

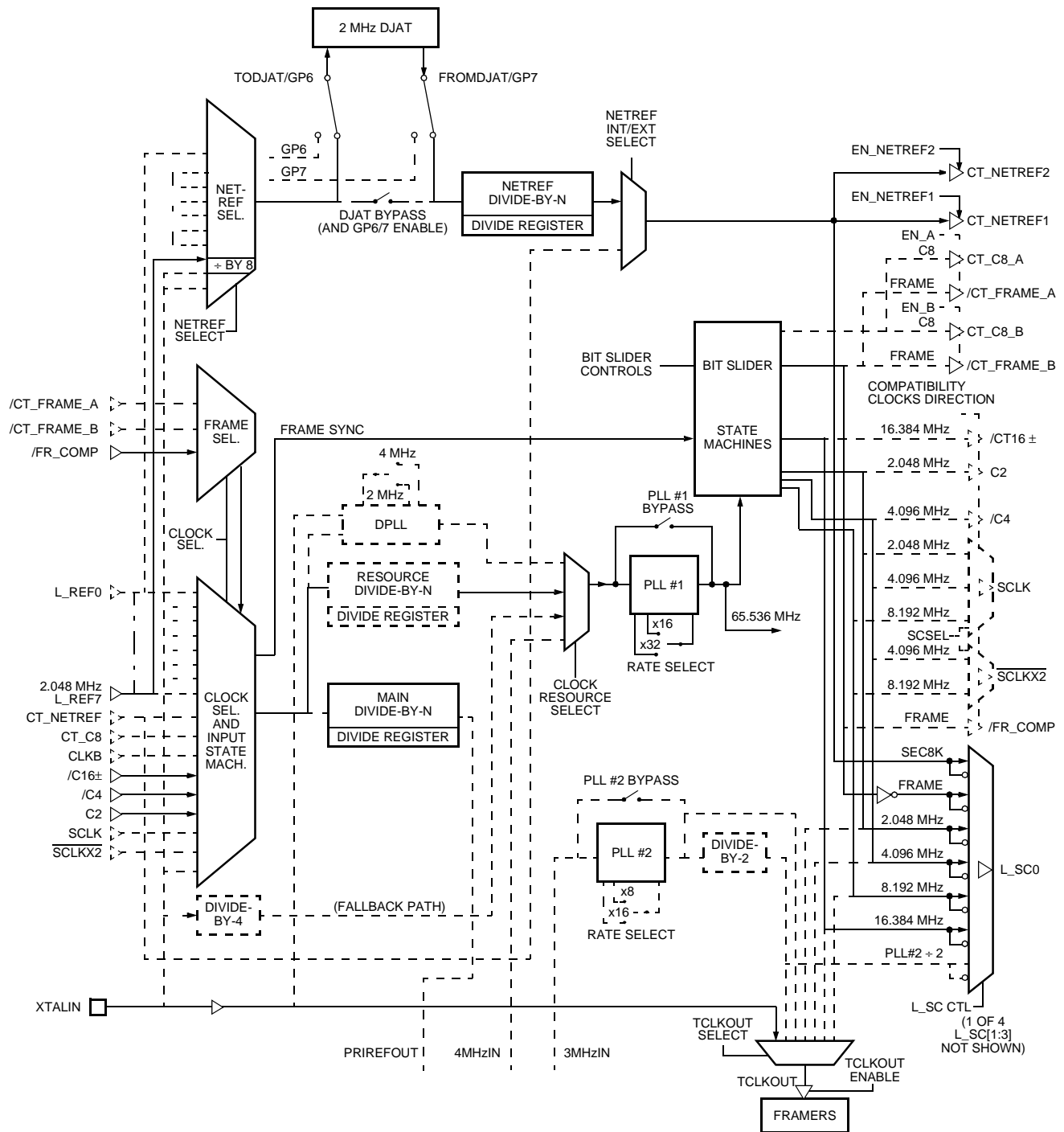

5-6131bF

Figure 37. E1, Slave to CT Bus, Clock Source Is Either a 16 MHz or a 4 MHz or a 2 MHz and Frame, NETREF Source = 2.048 MHz from Trunk

Appendix A. Application of Clock Modes (continued)

Table 82. Clock Register Programming Profile for the Four Previous Examples

Register Name	CT Bus Master (E1)	CT Bus Master (T1)	CT Bus Slave (E1)	CT Bus Slave (T1)
CKM	0010_1000b	0010_1000b	1100_0101b	1100_0101b
CKN	0110_0000b	0110_0000b	1000_1111b	1000_1111b
CKP	0010_0001b	0110_0001b	0010_0000b	0110_0000b
CKR	0001_0000b	0000_0000b	0100_0000b	0100_0000b
CKS	0000_0000b	0000_0000b	0000_0000b	0000_0000b
CK32	1001_0100b	1001_0100b	0010_0100b	0010_0100b
CK10	1101_1111b	1101_1111b	1000_0000b	1011_1101b
CKMD	0000_0000b	0000_0000b	0000_0000b	0000_0111b
CKND	0000_0000b	0000_0000b	1111_1111b	1100_0000b
CKRD	0000_0000b	0000_0000b	0000_0011b	0000_0011b
Watchdog: CKW	0011_1001b	0011_1001b	0011_1001b	0011_1001b

The programming displays how similar the four basic modes of operation are. Local outputs (CK32 and CK10) are obviously not constrained by the mode of operation. The primary difference between E1 and T1 is in the use of PLL #2 (which is optional). The primary difference between master and slave is in the clock path to PLL #1, which is covered by registers CKM, CKR, CKMD, and CKRD.

Note: CKR does include an example of running PLL #1 at X32 for E1 master and X16 for all other cases.

The watchdogs have been set up to monitor all CT bus signals, though fallback (to the oscillator) is shown as enabled in all examples. It is recommended that the default condition, CKS = 0x00, be used for systems which do not have specific fallback clocking schemes. Also, while programming the devices on powerup, it is recommended that the watchdogs are disabled (CKW = 0x00) until the device is fully programmed to prevent false error conditions (uninitialized clocks, for example) from changing the operating mode.

Appendix B. Minimum Delay and Constant Delay Connections

B.1 Connection Definitions

Forward Connection A forward connection is defined as one in which the output (**to**) time slot has a greater value than the input (**from**) time slot, or put another way, the delta between them is positive.

Reverse Connection A reverse connection is defined as one in which the output (**to**) time slot has a lesser value than the input (**from**) time slot, and the delta between them is negative.

So, for example, going from TS(1) to TS(38) is a forward connection, and the TS_{Δ} is +37, but going from TS(38) to TS(1) is a reverse connection, with a TS_{Δ} of -37:

where $TS_{\Delta} = TS(\mathbf{to}) - TS(\mathbf{from})$.

Similarly, a delta can be introduced for streams which will have a bearing in certain exceptions (discussed later):

$STR_{\Delta} = STR(\mathbf{to}) - STR(\mathbf{from})$

There is only one combination which forms a TS_{Δ} of +127 or -127:

$$TS_{\Delta} = TS(127) - TS(0) = +127, \text{ and}$$

$$TS_{\Delta} = TS(0) - TS(127) = -127,$$

but there are two combinations which form TS_{Δ} s of +126 or -126:

$$TS_{\Delta} = TS(127) - TS(1) = TS(126) - TS(0) = +126, \text{ and}$$
$$TS_{\Delta} = TS(1) - TS(127) = TS(0) - TS(126) = -126,$$

there are three combinations which yield +125 or -125, and so on.

The user can utilize the TS_{Δ} to control the latency of the resulting connection. In some cases, the latency must be minimized. In other cases, such as a block of connections which must maintain some relative integrity while crossing a frame boundary, the required latency of some of the connections may exceed one frame (>128 time slots) to maintain the integrity of this virtual frame.

Each device contains several bits for controlling latency. Each connection has a bit which is used for selecting one of two alternating data buffers. These bits are set in the local connection memory (T8100A, T8105 only) for local switching or in the tag register field of the CAM section for H-bus switching. There are also 2 bits in the CON register, address 0x0E, which can control the buffer selection on a chip-wide basis. Bit 1 of the register overrides the individual FME bits. Bit 0 becomes the global, chip-wide, FME setting.

Appendix B. Minimum Delay and Constant Delay Connections (continued)

B.2 Delay Type Definitions

Constant Delay This is a well-defined, predictable, and linear region of latency in which the **to** time slot is at least 128 time slots after the **from** time slot, but no more than 256 time slots after the **from** time slot.

Mathematically, constant delay latency is described as follows*, with L denoting latency, and FME set to the value indicated:

Forward Connections, FME = 1: $L = 128 + TS\Delta$ ($0 \leq TS\Delta \leq 127$)

Reverse Connections, FME = 0: $L = 256 + TS\Delta$ ($-127 \leq TS\Delta \leq 0$)

Example: Switching from TS(37) to TS(1) as a constant delay, the delta is -36 , so FME is set to 0 and the resulting latency is $256 - 36 = 220$ time slots. Thus, the connection will be made from TS(37) of Frame(n) to TS(1) of Frame(n + 2).

Simple Summary: Use constant delay for latencies of 128 to 256 time slots, set FME = 1 for forward connections, set FME = 0 for reverse connections.

* Since $TS\Delta = TS(\text{to}) - TS(\text{from})$, the user can modify the equations to solve for either TS(to) or TS(from).

Minimum Delay This is the most common type of switching, but has a shorter range than constant delay, and the user must be aware of exceptions caused by interactions between the device's internal pipeline and the dual buffering. The **to** time slot is at least three time slots after the **from** time slot, but no more than 128 time slots after the **from** time slot. Exceptions exist at $TS\Delta$ s of +1, +2, -126, and -127.

Forward Connections, FME = 0: $L = TS\Delta$ ($3 \leq TS\Delta \leq 127$)

Reverse Connections, FME = 1: $L = 128 + TS\Delta$ ($-125 \leq TS\Delta \leq 0$)

Example: Using the same switching from the example above, TS(37) to TS(1), the delta is -36 , so FME is set to 1 to effect the minimum delay (setting to 0 effects constant delay), and the resulting latency is $128 - 36 = 92$ time slots. The relative positions of the end time slots are the same in both minimum and constant delay (i.e., they both switch to TS[1]), but the actual data is delayed by an additional frame in the constant delay case.

Simple Summary: Use minimum delay for latencies of 3 to 128 time slots, set FME = 0 for forward connections, set FME = 1 for reverse connections.

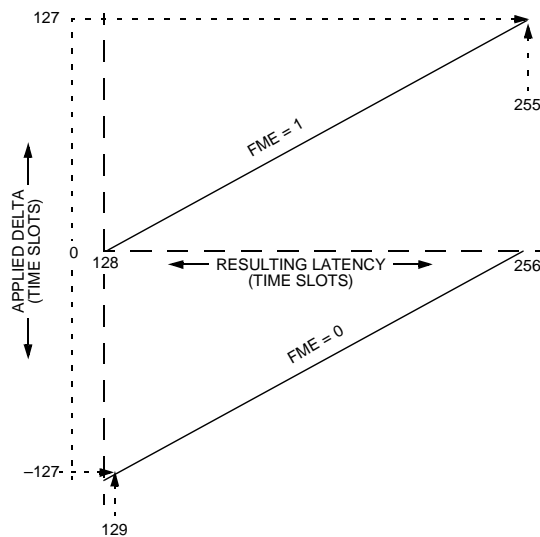

5-6223 (F)

Figure 39. Constant Delay Connections, CON[1:0] = 0X

Appendix B. Minimum Delay and Constant Delay Connections (continued)

B.2 Delay Type Definitions (continued)

B.2.1 Exceptions to Minimum Delay

Up until this point in the discussion, the STRDs have not been discussed because the **to** and **from** streams have been irrelevant in the switching process*. Rather than try to list the exceptions mathematically, a table is provided. The latencies in these cases may exceed two frames due to the interaction of the intrinsic pipeline delays with the double buffering.

Table 83. Table of Special Cases (Exceptions)

FME Value	TS Δ	Latency for STR Δ < 0	Latency for STR Δ \geq 0
0	+1	257	257
0	+2	258	2
1	-126	258	2
1	-127	257	257

Graphically, the minimum delay latency equations are illustrated below. The exceptions to the minimum delay have been included in the diagram, connected to the main function by dashed lines.

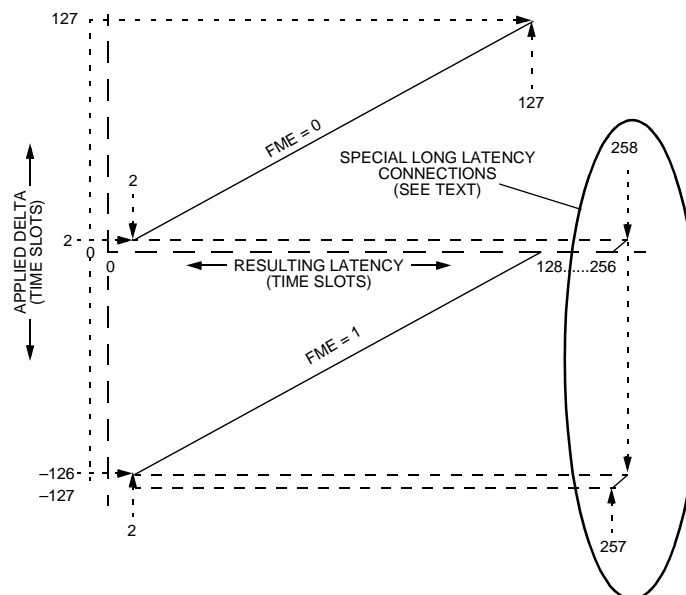

Figure 40. Minimum Delay Connections, CON[1:0] = 0X

B.2.2 Lower Stream Rates

The discussion has centered on 128 time-slot frames which correspond to 8.192 Mb/s data rates. How does one make similar predictions for lower stream rates?

For 4.096 Mb/s, multiply the **to** and **from** time-slot values by two (i.e., time slot 0 at 4.096 Mb/s corresponds to time slot 0 at 8.192 Mb/s, and time slot 63 at 4.096 Mb/s corresponds to time slot 126 at 8.192 Mb/s). Similarly, multiply values by four to convert 2.048 Mb/s values. The latency equations can then be applied directly.

* The one universally disallowed connection on the devices is a TS Δ of 0 and a STR Δ of 0. This is a stream and time-slot switching to itself. Loopback on the local bus (e.g., LDO_0 to LDI_0) is permissible.

Appendix B. Minimum Delay and Constant Delay Connections (continued)

B.2 Delay Type Definitions (continued)

B.2.3 Mixed Minimum/Constant Delay

An interesting mix of delays occurs when the individual FME bits are overridden and a chip-wide selection for FME is used. In short, when these devices are placed in this mode, and when register bits CON[1:0] = 10, forward connections provide minimum delay, reverse connections provide constant delay. When CON[1:0] = 11, reverse connections provide minimum delay, forward connections provide constant delay. The latter is interesting because, graphically, the $TS\Delta$ to latency map-

ping appears as a linear monotonic function covering 255 time slots. (Graphs are in the section which follows.) The latency equations follow:

$$CON[1:0] = 10:$$

$$\text{Forward Connections: } L = TS\Delta \quad (3 \leq TS\Delta \leq 127).$$

$$\text{Reverse Connections: } L = 256 + TS\Delta \quad (-127 \leq TS\Delta \leq 0).$$

$$CON[1:0] = 11:$$

$$\text{Forward and Reverse: } L = 128 + TS\Delta \quad (-125 \leq TS\Delta \leq 127).$$

Table 83, Table of Special Cases (Exceptions), applies to the mixed delays in a similar manner. Simply use bit 0 of CON for the FME value in Table 83.

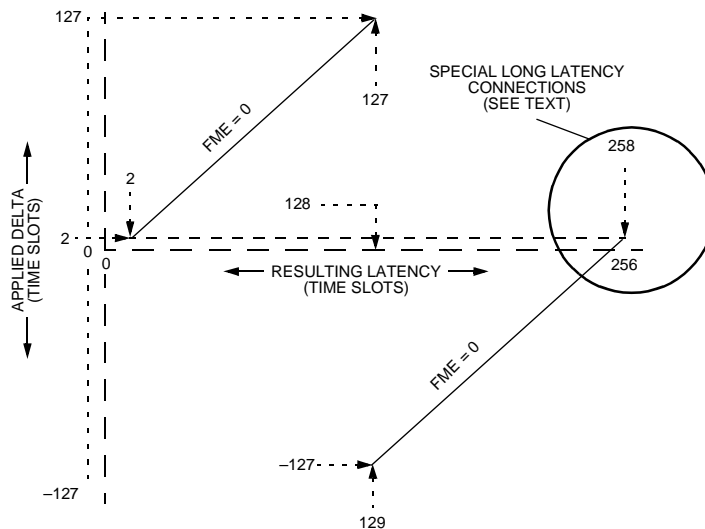

5-6225(F)

Figure 41. Mixed Minimum/Constant Delay Connections, CON[1:0] = 10]

Appendix B. Minimum Delay and Constant Delay Connections (continued)

B.2 Delay Type Definitions (continued)

B.2.3 Mixed Minimum/Constant Delay (continued)

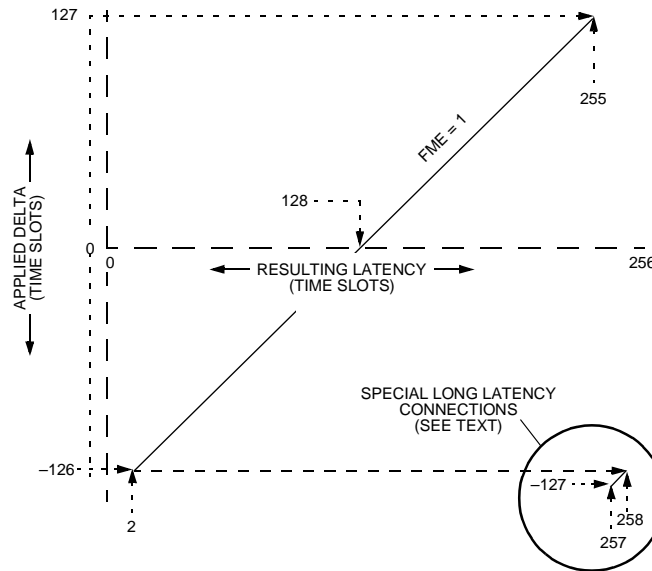

5-6226(F)

Figure 42. Extended Linear (Mixed Minimum/Constant) Delay, CON[1:0] = 11

Appendix C. CAM Readback and Pattern Fill Mode

Reading back local data memories (AMR = 0x01, 0x02), local connection memory (AMR = 0x05), or H.100 data memories (AMR = 0x90, 0xA0) simply yields whatever the expected pattern is. When reading back the CAM contents, however, there is some bit manipulation involved.

For additional information, contact your Microelectronics Group Account Manager or the following:

INTERNET: <http://www.lucent.com/micro>

E-MAIL: docmaster@micro.lucent.com

N. AMERICA: Microelectronics Group, Lucent Technologies Inc., 555 Union Boulevard, Room 30L-15P-BA, Allentown, PA 18103

1-800-372-2447, FAX 610-712-4106 (In CANADA: **1-800-553-2448**, FAX 610-712-4106)

ASIA PACIFIC: Microelectronics Group, Lucent Technologies Singapore Pte. Ltd., 77 Science Park Drive, #03-18 Cintech III, Singapore 118256

Tel. (65) 778 8833, FAX (65) 777 7495

CHINA: Microelectronics Group, Lucent Technologies (China) Co., Ltd., A-F2, 23/F, Zao Fong Universe Building, 1800 Zhong Shan Xi Road, Shanghai 200233 P. R. China **Tel. (86) 21 6440 0468, ext. 316**, FAX (86) 21 6440 0652

JAPAN: Microelectronics Group, Lucent Technologies Japan Ltd., 7-18, Higashi-Gotanda 2-chome, Shinagawa-ku, Tokyo 141, Japan

Tel. (81) 3 5421 1600, FAX (81) 3 5421 1700

EUROPE: Data Requests: MICROELECTRONICS GROUP DATALINE: **Tel. (44) 7000 582 368**, FAX (44) 1189 328 148

Technical Inquiries: GERMANY: **(49) 89 95086 0** (Munich), UNITED KINGDOM: **(44) 1344 865 900** (Ascot),

FRANCE: **(33) 1 40 83 68 00** (Paris), SWEDEN: **(46) 8 594 607 00** (Stockholm), FINLAND: **(358) 9 4354 2800** (Helsinki),

ITALY: **(39) 02 6608131** (Milan), SPAIN: **(34) 1 807 1441** (Madrid)

Lucent Technologies Inc. reserves the right to make changes to the product(s) or information contained herein without notice. No liability is assumed as a result of their use or application. No rights under any patent accompany the sale of any such product(s) or information. *Ambassador* is a trademark of Lucent Technologies Inc.

