



3/3.3/4.0 V μ P Supervisor Circuits

General Description

The ASM706P/R/S/T/J and ASM708R/S/T/J are cost effective CMOS supervisor circuits that monitor power-supply and battery voltage level, and μ P/ μ C operation.

The family offers several functional options. Each device generates a reset signal during power-up, power-down and during brownout conditions. A reset is generated when the supply drops below 2.63V (ASM706P/R, ASM708R), 2.93V (ASM706S, ASM708S), 3.08V (ASM706T, ASM708T) or 4.00V (ASM706J, ASM708J). In addition, the ASM706P/R/S/T/J feature a 1.6 second watchdog timer. The watchdog timer output will trigger a reset if connected to $\overline{\text{MR}}$. Floating the WDI input pin disables the watchdog timer.

The ASM708R/S/T/J have both active-HIGH and active-LOW reset outputs but no watchdog function. The ASM706P has the same pin-out and functions as the ASM706R but has an active-HIGH reset output.

A versatile power-fail circuit, useful in checking battery levels and non-5V supplies, has a 1.25V threshold. All devices have a manual reset input. All devices are available in 8-pin DIP, SO and the compact MicroSO packages. The MicroSO package requires 50% less PC board area than the conventional SO package.

Features

- Precision power supply monitor
 - 2.63V threshold (ASM706P/R, ASM708R)
 - 2.93V threshold (ASM706S, ASM708S)
 - 3.08V threshold (ASM706T, ASM708T)
 - New 4.00V threshold (ASM706J, ASM708J)
- Debounced manual reset input
- Auxiliary voltage monitor comparator
 - 1.25V threshold
- Battery monitor / auxiliary supply monitor
- Watchdog timer (ASM706P/R/S/T/J)
 - Watchdog can be disabled by floating WDI
- 200ms reset time delay
- Three reset signal options
 - Active HIGH: ASM706P
 - Active LOW: ASM706R/S/T/J
 - Active HIGH and LOW outputs: ASM708R/S/T/J
- DIP, SO and MicroSO packages
- Guaranteed RESET assertion to $V_{CC} = 1.1V$

Applications

- Computers and embedded controllers
- CTI applications
- Automotive systems
- Portable/Battery-operated systems
- Intelligent instruments
- Wireless communication systems
- PDAs and hand-held equipment
- Safety systems

Typical Operating Circuit

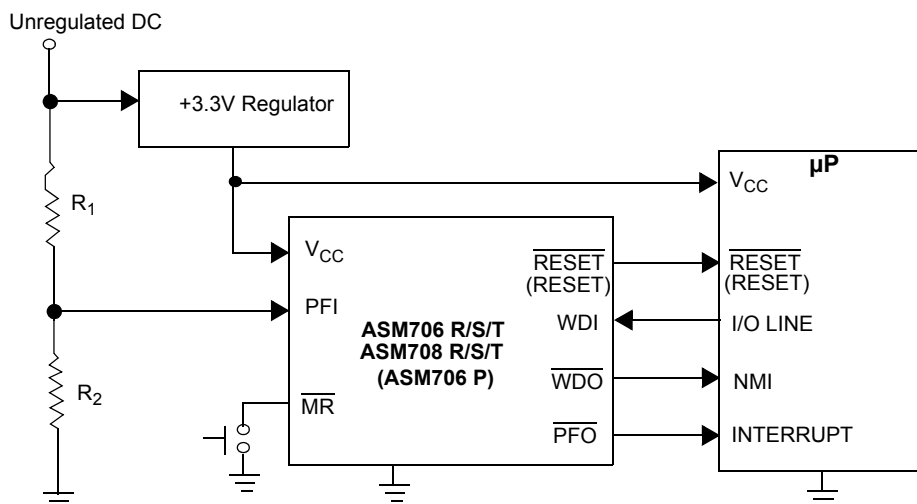



Block Diagrams

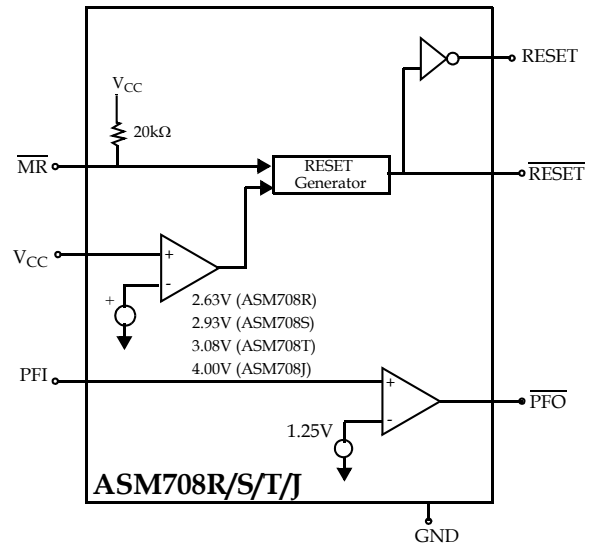
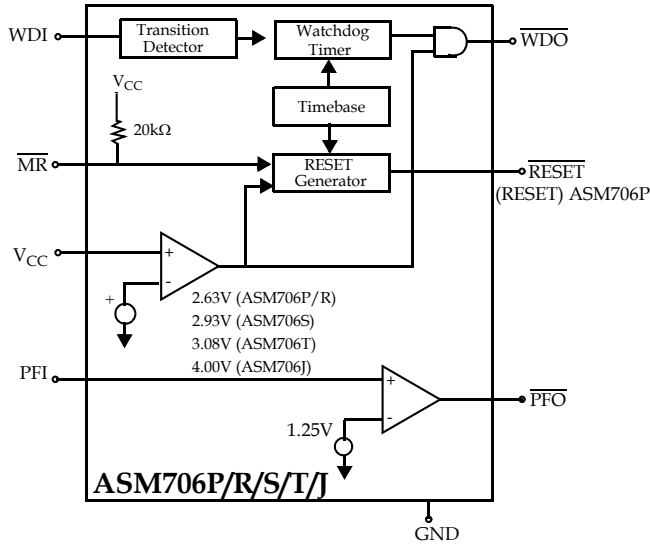

Pin Configuration

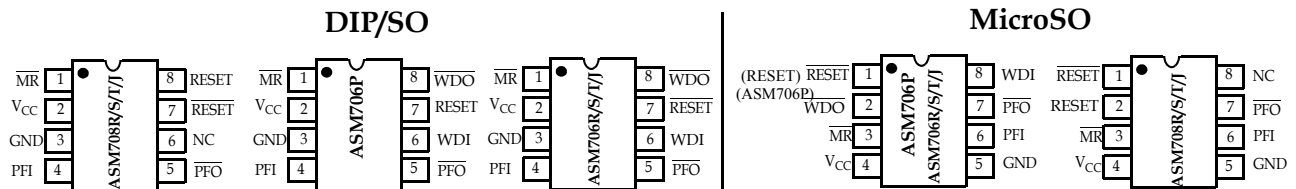



Pin Description

Pin Number						Name	Function
ASM706P		ASM706R/S/T/J		ASM708R/S/T/J			
DIP/ SO	MicroSO	DIP/ SO	MicroSO	DIP/ SO	MicroSO		
1	3	1	3	1	3	$\overline{\text{MR}}$	Manual reset input. The active LOW input triggers a reset pulse. It is pulled HIGH by a 20k Ω pull-up resistor. It is compatible with TTL/CMOS signals when $V_{\text{CC}} = 5\text{V}$. It can be shorted to ground through a mechanical switch. Leave floating or connect to V_{CC} if the function is not used.
2	4	2	4	2	4	V_{CC}	Monitored power supply input.
3	5	3	5	3	5	GND	Ground.
4	6	4	6	4	6	PFI	Power-fail input voltage monitor. With PFI less than 1.25V, $\overline{\text{PFO}}$ goes LOW. Connect PFI to Ground when not in use.
5	7	5	7	5	7	$\overline{\text{PFO}}$	Power-fail output. The output is active LOW and sinks current when PFI is less than 1.25V. If not used, leave the pin unconnected.
6	8	6	8	-	-	WDI	Watchdog input. WDI controls the internal watchdog timer. A HIGH or LOW signal for 1.6sec at WDI allows the internal timer to run-out, setting $\overline{\text{WDO}}$ low. A rising or falling edge must occur at WDI within 1.6 seconds or $\overline{\text{WDO}}$ goes LOW. The watchdog function is disabled by floating WDI. The internal watchdog timer clears when: RESET is asserted; WDI is three-stated ; or WDI sees a rising or falling edge.
-	-	-	-	6	8	NC	Not Connected
-	-	7	1	7	1	$\overline{\text{RESET}}$	Active LOW reset output. Pulses LOW for 200ms when triggered, and stays LOW whenever V_{CC} is below the reset threshold. RESET remains LOW for 200ms after V_{CC} rises above the reset threshold or $\overline{\text{MR}}$ goes from HIGH to LOW. A watchdog timeout will not trigger RESET unless $\overline{\text{WDO}}$ is connected to $\overline{\text{MR}}$.



Pin Number						Name	Function
ASM706P		ASM706R/S/T/J		ASM708R/S/T/J			
DIP/ SO	MicroSO	DIP/ SO	MicroSO	DIP/ SO	MicroSO		
8	2	8	2	-	-	$\overline{\text{WDO}}$	Watchdog output. $\overline{\text{WDO}}$ goes LOW when the 1.6 second interval watchdog timer times-out and does not go HIGH until a transition occurs at WDI. In addition, when V_{CC} falls below the reset threshold, $\overline{\text{WDO}}$ goes LOW. Unlike RESET, $\overline{\text{WDO}}$ does not have a minimum pulse width and as soon as V_{CC} exceeds the reset threshold, $\overline{\text{WDO}}$ becomes HIGH with no delay.
7	1	-	-	8	2	RESET	Active HIGH reset output. The inverse of $\overline{\text{RESET}}$.



rev 1.0

Detailed Descriptions

A proper reset input enables a microprocessor/microcontroller to start in a known state. ASM706 P/ R/ S/ T/ J and ASM708 R/ S/ T/ J assert reset to prevent code execution errors during power-up, power-down and brown-out conditions.

RESET/RESETE Operation

The RESET/RESETE signals are designed to start or return a $\mu\text{P}/\mu\text{C}$ to a known state.

With V_{CC} above 1.2V, RESET and RESETE are guaranteed to be asserted. During a power-up sequence, the reset outputs remain asserted until the supply rises above the threshold level. The resets are deasserted approximately 200ms after crossing the threshold.

In a brownout situation where V_{CC} falls below the threshold level, the reset outputs are asserted. If a brownout occurs during an already initiated reset period, the reset period will extend for an additional reset period of 200ms.

The ASM708 devices have dual reset outputs, one active LOW and one active HIGH. The ASM706P has a single active HIGH reset and the ASM706/R/S/T/J devices have an active LOW reset output.

Alliance Part #	RESET Polarity	Threshold	Watchdog Timer
ASM706P	HIGH	2.63V	YES
ASM706R	LOW	2.63V	YES
ASM706S	LOW	2.93V	YES
ASM706T	LOW	3.08V	YES
ASM706J	LOW	4.00V	YES
ASM708R	HIGH & LOW	2.63V	NO
ASM708S	HIGH & LOW	2.93V	NO
ASM708T	HIGH & LOW	3.08V	NO
ASM708J	HIGH & LOW	4.00V	NO

Manual Reset (MR)

The active-LOW manual reset input is pulled high by an internal 20k Ω pull-up resistor and can be driven low by CMOS/TTL logic or a mechanical switch to ground. An external debounce circuit is unnecessary since the 140ms minimum reset time will debounce mechanical pushbutton switches. The minimum MR input pulse width is 0.5 μs with a 3V V_{CC} input and 0.15 μs with a 5V V_{CC} input. If not used, tie MR to V_{CC} or leave floating.

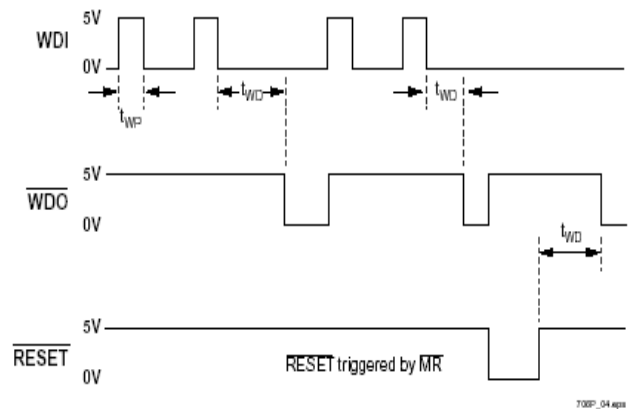

Figure 1: WDI Three-state operation

By connecting the watchdog output (WDO) and MR, a watchdog timeout forces a RESET to be generated.

Watchdog Timer

A watchdog timer available on the ASM706P/R/S/T/J monitors $\mu\text{P}/\mu\text{C}$ activity. An output line on the processor is used to toggle the WDI line. If the line is not toggled within 1.6 seconds on the Watchdog Input (WDI), the internal timer puts the Watchdog Output (WDO) into a LOW state. WDO will remain LOW until a toggle is detected at WDI.

The watchdog function is disabled, meaning it is cleared and not counting, if WDI is floated or connected to a three-stated circuit. The watchdog timer is also disabled if RESET is asserted. When RESET becomes inactive and the WDI input sees a high or low transition as short as 100ns ($V_{CC} = 2.7\text{V}$)



rev 1.0

50ns ($V_{CC} = 4.5V$), the watchdog timer will begin a 1.6 second countdown. Additional transitions at \overline{WDI} will reset the watchdog timer and initiate a new countdown sequence. \overline{WDO} will also become LOW and remain so, whenever the supply voltage, V_{CC} , falls below the device threshold level. \overline{WDO} goes HIGH as soon as V_{CC} transitions above the threshold. There is no minimum pulse width for \overline{WDO} as there is for the RESET outputs. If \overline{WDI} is floated, \overline{WDO} essentially acts as a low supply voltage output indicator.

Power-failure Detection With Auxiliary Comparator

All devices have an auxiliary comparator with 1.25V trip point. The output, \overline{PFO} , is active LOW and the noninverting input is PFI. This comparator can be used as a supply voltage monitor with an external resistor voltage divider. As the monitored voltage level falls, PFI is reduced causing the \overline{PFO} output to go LOW. Normally \overline{PFO} interrupts the processor so the system can be shut down in a controlled manner.

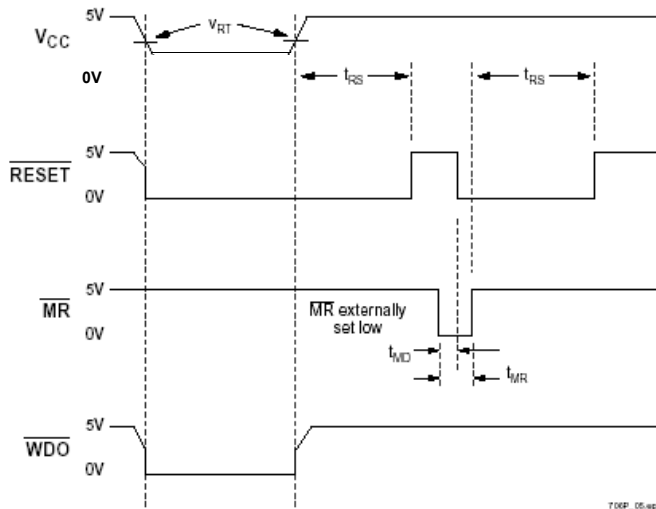

Figure 2: Watchdog timing

Application Information

Bi-directional Reset Pin Interfacing

The ASM706/8 can interface with $\mu P/\mu C$ bi-directional reset pins by connecting a 4.7k Ω resistor in series with the RESET output and the $\mu P/\mu C$ bi-directional reset pin.

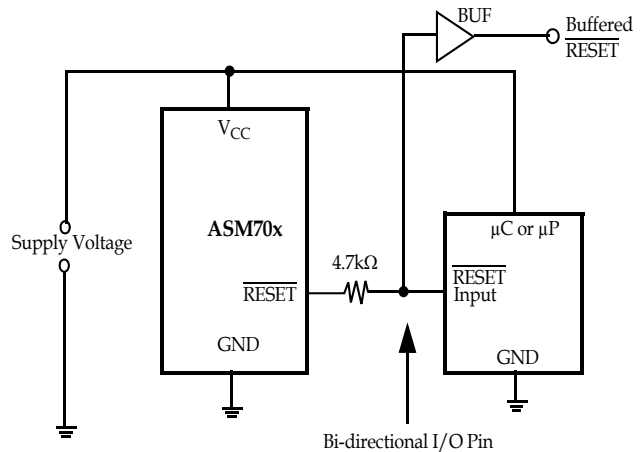

Figure 3: Bi-directional reset pin interfacing

Ensuring the \overline{RESET} is Valid Down to $V_{CC} = 0V$

When V_{CC} falls below 1.2V, the ASM706R/S/T/J and 708R/S/T/J \overline{RESET} reset outputs no longer pull down; it becomes indeterminate. To avoid the possibility that stray charges could build up and force \overline{RESET} to the wrong state, a pull-down resistor should be connected to the \overline{RESET} pin, thus draining such charges to ground. The resistor value is not critical. A100k Ω resistor will pull \overline{RESET} to ground without loading it.



rev 1.0

Monitoring Voltages Other Than V_{CC}

The ASM706/708 can monitor voltages other than V_{CC} using the Power Fail circuitry. If a resistive divider is connected from the voltage to be monitored to the PFI input, the $\overline{\text{PFO}}$ will go LOW if the voltage at PFI goes below 1.25V reference. Should hysteresis be desired, connect a resistor (equal to approximately 10 times the sum of the two resistors in the divider) between the PFI and $\overline{\text{PFO}}$ pins. A capacitor between PFI and GND will reduce circuit sensitivity to input high frequency noise. If it is desired to assert a reset in addition to the $\overline{\text{PFO}}$ flag, this may be achieved by connecting the $\overline{\text{PFO}}$ output to $\overline{\text{MR}}$.

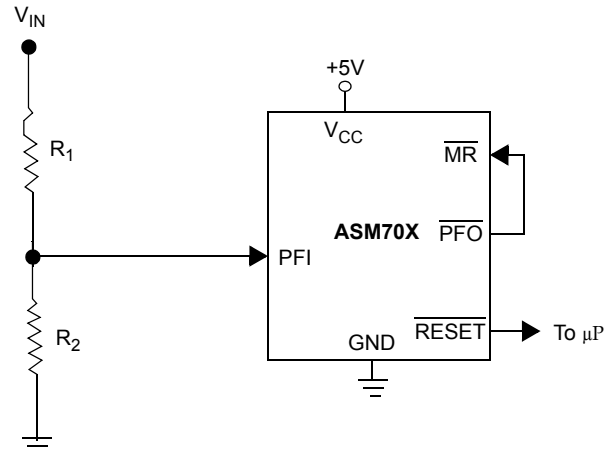

Figure 4: Monitoring +5V and an additional supply V_{IN}

Absolute Maximum Ratings

Parameter	Min	Max	Unit
Pin Terminal Voltage with Respect to Ground			
V _{CC}	-0.3	6.0	V
All other inputs	-0.3	V _{CC} + 0.3	V
Input Current at V _{CC} and GND		20	mA
Output Current: All outputs		20	mA
Rate of Rise at V _{CC}		100	V/μs
Plastic DIP Power Dissipation (Derate 9mW/°C above 70°C)		700	mW
SO Power Dissipation (Derate 5.9mW/°C above 70°C)		470	mW
MicroSO Power Dissipation (Derate 4.1mW/°C above 70°C)		330	mW
Operating Temperature Range			
ASM706xE, ASM708xE	-40	+85	°C
ASM706xC, ASM708xC	0	70	°C
Storage Temperature Range	-65	160	°C
Lead Temperature Soldering (10sec)		300	°C
Note: These are stress ratings only and functional operation is not implied. Exposure to absolute maximum ratings for prolonged time periods may affect device reliability.			



Electrical Characteristics

Unless otherwise noted, specifications are over the operating temperature range and V_{CC} supply voltages are 2.7V to 5.5V (ASM706P, ASM708R), 3.0 V to 5.5V (ASM706/708S), 3.15V to 5.5V (ASM706/708T) and 4.1V to 5.5.V (ASM706/708J)

Parameter	Symbol	Conditions	Min	Typ	Max	Unit
Operating Voltage Range	V_{CC}	ASM706xC, ASM708xC	1.1		5.5	V
		ASM706xE, ASM708xE	1.2		5.5	
Supply Current $V_{CC} < 3.6V$	I_{CC}	ASM706xC, ASM706xE, $\overline{MR} = V_{CC}$, WDI Floating		75	140	μA
		ASM708xC, ASM708xE, $\overline{MR} = V_{CC}$, WDI Floating		50	140	
Supply Current $V_{CC} < 5.5V$	I_{CC}	ASM706xC, ASM706xE, $\overline{MR} = V_{CC}$, WDI Floating		75	140	μA
		ASM708xC, ASM708xE, $\overline{MR} = V_{CC}$, WDI Floating		50	140	
RESET Threshold	V_{RT}	P and R devices	2.55	2.63	2.70	V
		S devices	2.85	2.93	3.00	
		T devices	3.00	3.08	3.15	
		J devices	3.89	4.00	4.10	
RESET Threshold Hysteresis			40			mV
RESET Pulse Width	t_{RS}	$V_{CC} = 3V$ (ASM706/8, P/R devices).	140	200	280	ms
		$V_{CC} = 3.3V$ (ASM706/8, S/T devices).				
		$V_{CC} = 4.4V$ (ASM706/8, J devices).				
		$V_{CC} = 5V$				
\overline{MR} Pulse Width	t_{MR}	$4.5V < V_{CC} < 5.5V$	150			ns
		$3.6V < V_{CC} < 4.5V$ (ASM706/8J devices) $V_{RST (MAX)} < V_{CC} < 3.6V$ (ASM706/8/P/R/S/T devices)	500			
\overline{MR} to RESET Out Delay	t_{MD}	$3.6V < V_{CC} < 4.5V$ (AS706/8J devices) $V_{RST (MAX)} < V_{CC} < 3.6V$ (ASM706/8/P/R/S/T devices)			750	ns
		$4.5V < V_{CC} < 5.5V$			250	



Parameter	Symbol	Conditions	Min	Typ	Max	Unit
$\overline{\text{MR}}$ Input Threshold	V_{IH}	$V_{RST(MAX)} < V_{CC} < 4.5V$	$0.7V_{CC}$		0.6	V
	V_{IL}	$V_{RST(MAX)} < V_{CC} < 4.5V$				
	V_{IH}	$4.5V < V_{CC} < 5.5V$	2.0			
	V_{IL}	$4.5V < V_{CC} < 5.5V$				
$\overline{\text{MR}}$ Pullup resistor	R_P		10	20	40	$k\Omega$
$\overline{\text{RESET}}$ Output Voltage (All R/S/T/J devices)	V_{OH}	$I_{SOURCE} = 800\mu A, 4.5V < V_{CC} < 5.5V$	$V_{CC} - 1.5$		0.4	V
	V_{OL}	$I_{SINK} = 3.2mA, 4.5V < V_{CC} < 5.5V$				
	V_{OH}	$I_{SOURCE} = 500\mu A, V_{RST(MAX)} < V_{CC} < 4.5V$	$0.8V_{CC}$			
	V_{OL}	$I_{SINK} = 1.2mA, V_{RST(MAX)} < V_{CC} < 4.5V$			0.3	
	V_{OL}	$I_{SINK} = 50\mu A, V_{CC} = 1.1V$ (ASM706xC, ASM708xC devices)			0.3	
	V_{OL}	$I_{SINK} = 100\mu A, V_{CC} = 1.2V$ (ASM706xE, ASM708xE devices)			0.3	
RESET Output Voltage ASM706P	V_{OH}	$I_{SOURCE} = 800\mu A, 4.5V < V_{CC} < 5.5V$	$V_{CC} - 1.5$		0.4	V
	V_{OL}	$I_{SINK} = 3.2mA, 4.5V < V_{CC} < 5.5V$				
	V_{OH}	$I_{SOURCE} = 500\mu A, V_{RST(MAX)} < V_{CC} < 3.6V$	$0.8V_{CC}$			
	V_{OL}	$I_{SINK} = 1.2mA, V_{RST(MAX)} < V_{CC} < 3.6V$			0.3	
RESET Output Voltage ASM708R/S/T/J	V_{OH}	$I_{SOURCE} = 800\mu A, 4.5V < V_{CC} < 5.5V$	$V_{CC} - 1.5$		0.4	V
	V_{OL}	$I_{SINK} = 3.2mA, 4.5V < V_{CC} < 5.5V$				
	V_{OH}	$I_{SOURCE} = 500\mu A, V_{RST(MAX)} < V_{CC} < 4.5V$	$0.8V_{CC}$			
	V_{OL}	$I_{SINK} = 1.2mA, V_{RST(MAX)} < V_{CC} < 4.5V$			0.3	
Watchdog Timeout Period	t_{WD}	$V_{CC} = 3V$ (ASM706, P/R devices).	1.0	1.6	2.25	s
		$V_{CC} = 3.3V$ (ASM706 S/T devices).				
		$V_{CC} = 4.4V$ (ASM706, J devices).				
WDI Pulse Width	t_{WP}	$V_{IL} = 0.4V, V_{IH} = 0.8V_{CC},$ $V_{RST(MAX)} < V_{CC} < 4.5V$	100			ns
		$V_{IL} = 0.4V, V_{IH} = 0.8V_{CC},$ $4.5V < V_{CC} < 5.5V$	50			



Parameter	Symbol	Conditions	Min	Typ	Max	Unit
WDI Input Threshold	V_{IH}	$V_{CC} = 5V$	3.5			V
	V_{IL}				0.8	
	V_{IH}	$V_{RST(MAX)} < V_{CC} < 4.5V$	$0.7V_{CC}$			
	V_{IL}				0.6	
WDI Input Current		WDI = V_{CC} , ASM706 only		50	150	μA
		WDI = 0V, ASM706 only	-150	-50		
\overline{WDO} Output Voltage	V_{OH}	$I_{SOURCE} = 800\mu A$, $4.5V < V_{CC} < 5.5V$	$V_{CC} - 1.5$			V
	V_{OL}	$I_{SINK} = 1.2mA$, $4.5V < V_{CC} < 5.5V$			0.4	
	V_{OH}	$I_{SOURCE} = 500\mu A$, $V_{RST(MAX)} < V_{CC} < 4.5V$	$0.8V_{CC}$			
	V_{OL}	$I_{SINK} = 1.2mA$, $V_{RST(MAX)} < V_{CC} < 4.5V$			0.3	
PFI Input Threshold		PFI falling. For P/R devices $V_{CC} = 3V$. For S/T devices $V_{CC} = 3.3V$. For J devices $V_{CC} = 4.4V$	1.2	1.25	1.3	V
PFI Input Current			-25	0.01	25	nA
\overline{PFO} Output Voltage	V_{OH}	$I_{SOURCE} = 800\mu A$, $4.5V < V_{CC} < 5.5V$	$V_{CC} - 1.5$			V
	V_{OL}	$I_{SINK} = 3.2mA$, $4.5V < V_{CC} < 5.5V$			0.4	
	V_{OH}	$I_{SOURCE} = 500\mu A$, $V_{RS(MAX)} < V_{CC} < 4.5V$	$0.8V_{CC}$			
	V_{OL}	$I_{SINK} = 1.2mA$, $V_{RS(MAX)} < V_{CC} < 4.5V$			0.3	



Package Dimensions

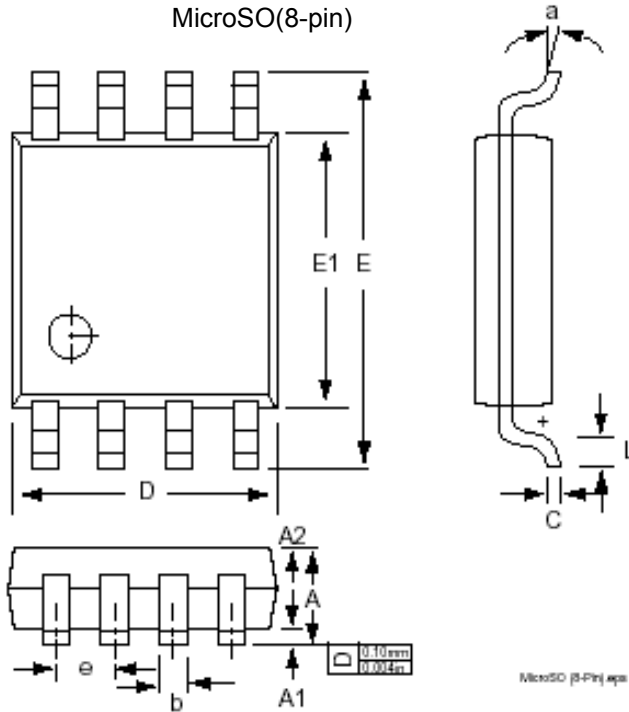

	Inches		Millimeters	
	Min	Max	Min	Max
A	-	0.0433	-	1.10
A1	0.0020	0.0059	0.050	0.15
A2	0.0295	0.0374	0.75	0.95
b	0.0098	0.0157	0.25	0.40
C	0.0051	0.0091	0.13	0.23
D	0.1142	0.1220	2.90	3.10
e	0.0256		0.65BS	
E	0.193B		4.90BS	
E1	0.1142	0.1220	2.90	3.10
L	0.0157	0.0276	0.40	0.70
a	0°	6°	0°	6°

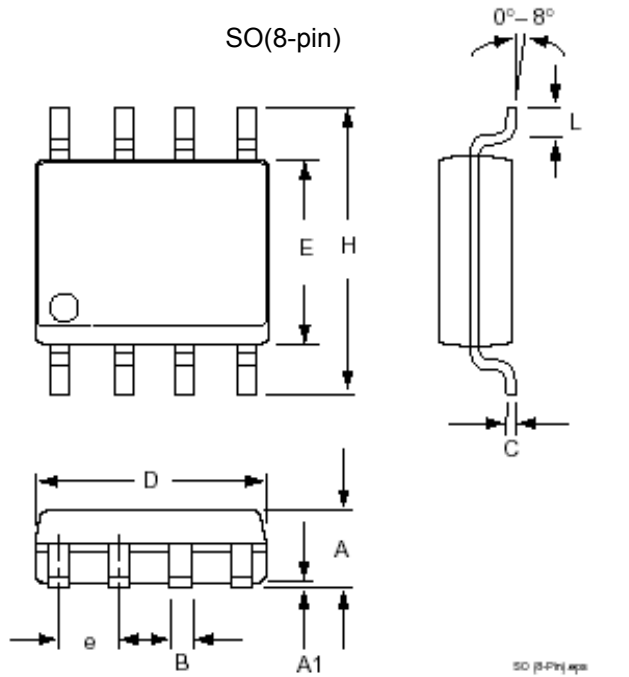

	Inches		Millimeters	
	Min	Max	Min	Max
A	0.053	0.069	1.35	1.75
A1	0.004	0.010	0.10	0.25
B	0.013	0.020	0.33	0.51
C	0.007	0.010	0.19	0.25
e	0.050		1.27	
E	0.150	0.157	3.80	4.00
H	0.228	0.244	5.80	6.20
L	0.016	0.50	0.40	1.27
D	0.189	0.197	4.80	2.00



Plastic DIP(8-pin)

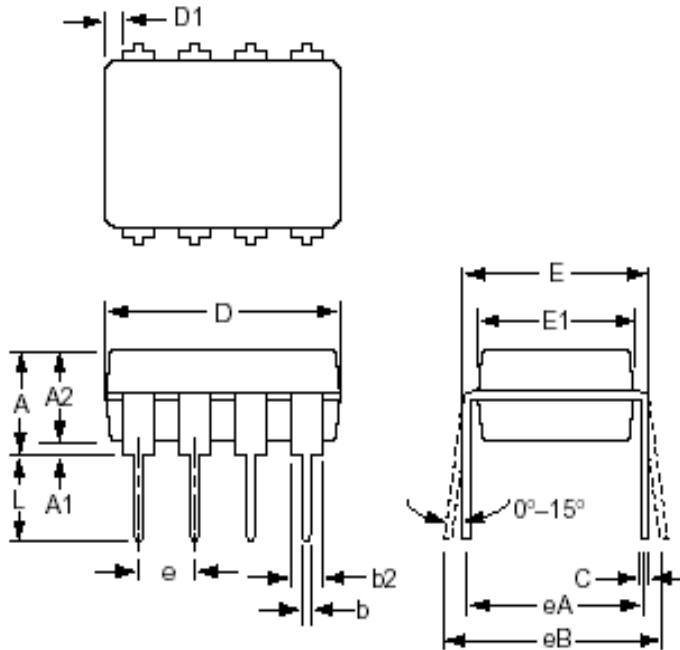

	Inches		Millimeters	
	Min	Max	Min	Max
A	-	0.210	-	5.33
A1	0.015	-	0.38	-
A2	0.115	0.195	2.92	4.95
b	0.014	0.022	0.36	0.56
b2	0.045	0.070	1.14	1.78
b3	0.030	0.045	0.080	1.14
D	0.355	0.400	9.02	10.16
D1	0.005	-	0.13	-
E	0.300	0.325	7.62	8.26
E1	0.240	0.280	6.10	7.11
e	0.100	-	2.54	
eA	0.300	-	7.62	
eB	-	0.430	-	10.92
eC	-	0.060		
L	0.115	0.150	2.92	3.81



Ordering Codes

Part Number	Package	Operating Temperature Range (°C)	Reset Threshold	Reset Polarity	Watchdog Timer
ASM706PCPA	8- Plastic DIP	0 to +70	2.63	HIGH	YES
ASM706PCSA	8-SO	0 to +70	2.63	HIGH	YES
ASM706PCUA	8-MicroSO	0 to +70	2.63	HIGH	YES
ASM706PEPA	8-Plastic DIP	-40 to +85	2.63	HIGH	YES
ASM706PESA	8-SO	-40 to +85	2.63	HIGH	YES
ASM706RCPA	8- Plastic DIP	0 to +70	2.63	LOW	YES
ASM706RCSA	8-SO	0 to +70	2.63	LOW	YES
ASM706RCUA	8-MicroSO	0 to +70	2.63	LOW	YES
ASM706REPA	8-Plastic DIP	-40 to +85	2.63	LOW	YES
ASM706RESA	8-SO	-40 to +85	2.63	LOW	YES
ASM706SCPA	8- Plastic DIP	0 to +70	2.93	LOW	YES
ASM706SCSA	8-SO	0 to +70	2.93	LOW	YES
ASM706SCUA	8-MicroSO	0 to +70	2.93	LOW	YES
ASM706SEPA	8-Plastic DIP	-40 to +85	2.93	LOW	YES
ASM706SESA	8-SO	-40 to +85	2.93	LOW	YES
ASM706TCPA	8- Plastic DIP	0 to +70	3.08	LOW	YES
ASM706TCSA	8-SO	0 to +70	3.08	LOW	YES
ASM706TCUA	8-MicroSO	0 to +70	3.08	LOW	YES
ASM706TEPA	8-Plastic DIP	-40 to +85	3.08	LOW	YES
ASM706TESA	8-SO	-40 to +85	3.08	LOW	YES
ASM706JCPA	8- Plastic DIP	0 to +70	4.00	LOW	YES
ASM706JCSA	8-SO	0 to +70	4.00	LOW	YES
ASM706JCUA	8-MicroSO	0 to +70	4.00	LOW	YES
ASM706JEPA	8-Plastic DIP	-40 to +85	4.00	LOW	YES
ASM706JESA	8-SO	-40 to +85	4.00	LOW	YES
ASM708RCPA	8- Plastic DIP	0 to +70	2.63	Dual: HIGH & LOW	NO
ASM708RCSA	8-SO	0 to +70	2.63	Dual: HIGH & LOW	NO
ASM708RCUA	8-MicroSO	0 to +70	2.63	Dual: HIGH & LOW	NO



Part Number	Package	Operating Temperature Range (°C)	Reset Threshold	Reset Polarity	Watchdog Timer
ASM708REPA	8-Plastic DIP	-40 to +85	2.63	Dual: HIGH & LOW	NO
ASM708RESA	8-SO	-40 to +85	2.63	Dual: HIGH & LOW	NO
ASM708SCPA	8- Plastic DIP	0 to +70	2.93	Dual: HIGH & LOW	NO
ASM708SCSA	8-SO	0 to +70	2.93	Dual: HIGH & LOW	NO
ASM708SCUA	8-MicroSO	0 to +70	2.93	Dual: HIGH & LOW	NO
ASM708SEPA	8-Plastic DIP	-40 to +85	2.93	Dual: HIGH & LOW	NO
ASM708SESA	8-SO	-40 to +85	2.93	Dual: HIGH & LOW	NO
ASM708TCPA	8- Plastic DIP	0 to +70	3.08	Dual: HIGH & LOW	NO
ASM708TCSA	8-SO	0 to +70	3.08	Dual: HIGH & LOW	NO
ASM708TCUA	8-MicroSO	0 to +70	3.08	Dual: HIGH & LOW	NO
ASM708TEPA	8-Plastic DIP	-40 to +85	3.08	Dual: HIGH & LOW	NO
ASM708TESA	8-SO	-40 to +85	3.08	Dual: HIGH & LOW	NO
ASM708JCPA	8- Plastic DIP	0 to +70	4.00	Dual: HIGH & LOW	NO
ASM708JCSA	8-SO	0 to +70	4.00	Dual: HIGH & LOW	NO
ASM708JCUA	8-MicroSO	0 to +70	4.00	Dual: HIGH & LOW	NO
ASM708JEPA	8-Plastic DIP	-40 to +85	4.00	Dual: HIGH & LOW	NO
ASM708JESA	8-SO	-40 to +85	4.00	Dual: HIGH & LOW	NO



Feature Summary

	ASM706P	ASM706R	ASM706S	ASM706 T	ASM706J	ASM708R	ASM708S	ASM708T	ASM708J
Power fail detector	◆	◆	◆	◆	◆	◆	◆	◆	◆
Brownout detection	◆	◆	◆	◆	◆	◆	◆	◆	◆
Debounced Manual RESET	◆	◆	◆	◆	◆	◆	◆	◆	◆
Power-up/down RESET	◆	◆	◆	◆	◆	◆	◆	◆	◆
Watchdog Timer	◆	◆	◆	◆	◆				
Active HIGH RESET	◆								
Active LOW RESET		◆	◆	◆	◆				
Active LOW and HIGH RESETs						◆	◆	◆	◆
RESET Threshold (V)	2.63	2.63	2.93	3.08	4.00	2.63	2.93	3.08	4.00

ASM706 P/ R/ S/ T/ J
ASM708 R/ S/ T/ J



Alliance Semiconductor Corporation
2575, Augustine Drive,
Santa Clara, CA 95054
Tel: 408 - 855 - 4900
Fax: 408 - 855 - 4999
www.alsc.com

Copyright © Alliance Semiconductor
All Rights Reserved
Part Number: ASM706 P/ R/ S/ T/ J
ASM708 R/ S/ T/ J
Document Version: 1.0

© Copyright 2003 Alliance Semiconductor Corporation. All rights reserved. Our three-point logo, our name and Intelliwatt are trademarks or registered trademarks of Alliance. All other brand and product names may be the trademarks of their respective companies. Alliance reserves the right to make changes to this document and its products at any time without notice. Alliance assumes no responsibility for any errors that may appear in this document. The data contained herein represents Alliance's best data and/or estimates at the time of issuance. Alliance reserves the right to change or correct this data at any time, without notice. If the product described herein is under development, significant changes to these specifications are possible. The information in this product data sheet is intended to be general descriptive information for potential customers and users, and is not intended to operate as, or provide, any guarantee or warrantee to any user or customer. Alliance does not assume any responsibility or liability arising out of the application or use of any product described herein, and disclaims any express or implied warranties related to the sale and/or use of Alliance products including liability or warranties related to fitness for a particular purpose, merchantability, or infringement of any intellectual property rights, except as express agreed to in Alliance's Terms and Conditions of Sale (which are available from Alliance). All sales of Alliance products are made exclusively according to Alliance's Terms and Conditions of Sale. The purchase of products from Alliance does not convey a license under any patent rights, copyrights; mask works rights, trademarks, or any other intellectual property rights of Alliance or third parties. Alliance does not authorize its products for use as critical components in life-supporting systems where a malfunction or failure may reasonably be expected to result in significant injury to the user, and the inclusion of Alliance products in such life-supporting systems implies that the manufacturer assumes all risk of such use and agrees to indemnify Alliance against all claims arising from such use.