

DESCRIPTION

THE Hynix HY57V161610E is a 16,777,216-bits CMOS Synchronous DRAM, ideally suited for the main memory and graphic applications which require large memory density and high bandwidth. HY57V161610E is organized as 2banks of 524,288x16.

HY57V161610E is offering fully synchronous operation referenced to a positive edge clock. All inputs and outputs are synchronized with the rising edge of the clock input. The data paths are internally pipelined to achieve very high bandwidth. All input and output voltage levels are compatible with LVTTTL.

Programmable options include the length of pipeline (Read latency of 1,2 or 3), the number of consecutive read or write cycles initiated by a single control command (Burst length of 1,2,4,8 or full page), and the burst count sequence(sequential or interleave). A burst of read or write cycles in progress can be terminated by a burst terminate command or can be interrupted and replaced by a new burst read or write command on any cycle. (This pipeline design is not restricted by a '2N' rule.)

FEATURES

- Single 3.0V to 3.6V power supply
- All device pins are compatible with LVTTTL interface
- JEDEC standard 400mil 50pin TSOP-II with 0.8mm of pin pitch(Lead Free)
- All inputs and outputs referenced to positive edge of system clock
- Data mask function by UDQM/LDQM
- Internal two banks operation
- Auto refresh and self refresh
- 4096 refresh cycles / 64ms
- Programmable Burst Length and Burst Type
 - 1, 2, 4, 8 and Full Page for Sequence Burst
 - 1, 2, 4 and 8 for Interleave Burst
- Programmable $\overline{\text{CAS}}$ Latency ; 1, 2, 3 Clocks

ORDERING INFORMATION

Part No.	Clock Frequency	Organization	Interface	Package
HY57V161610ETP-5	200MHz	2Banks x 512Kbits x 16	LVTTTL	400mil 50pin TSOP II
HY57V161610ETP-55	183MHz			
HY57V161610ETP-6	166MHz			
HY57V161610ETP-7	143MHz			
HY57V161610ETP-8	125MHz			
HY57V161610ETP-10	100MHz			
HY57V161610ETP-15	66MHz			

Note :

1. VDD(min) of HY57V161610ETP-5/55 is 3.15V

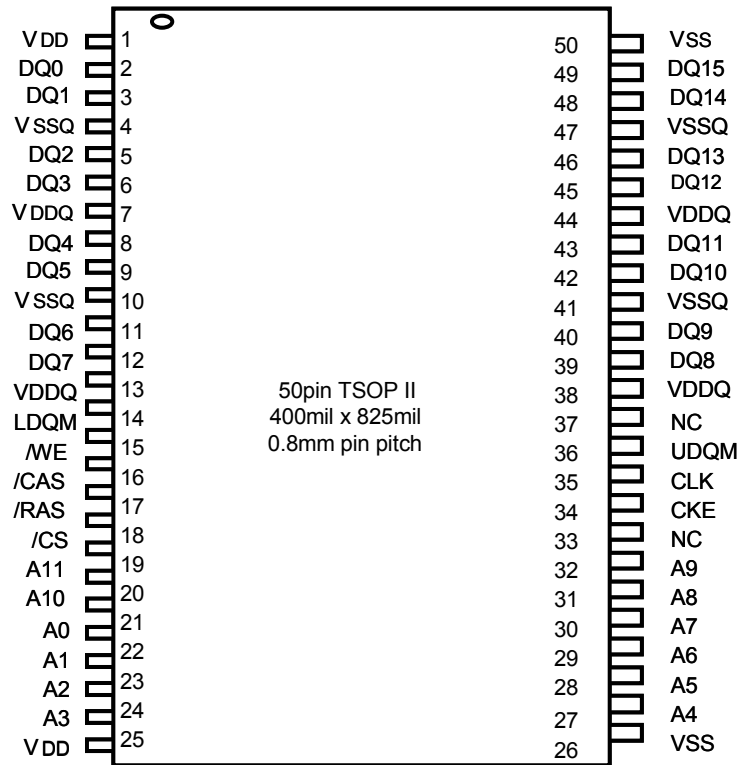
PIN CONFIGURATION

PIN DESCRIPTION

PIN	PIN NAME	DESCRIPTION
CLK	Clock	The system clock input. All other inputs are referenced to the SDRAM on the rising edge of CLK.
CKE	Clock Enable	Controls internal clock signal and when deactivated, the SDRAM will be one of the states among power down, suspend or self refresh.
$\overline{\text{CS}}$	Chip Select	Command input enable or mask except CLK, CKE and DQM
BA	Bank Address	Select either one of banks during both $\overline{\text{RAS}}$ and $\overline{\text{CAS}}$ activity.
A0 ~ A10	Address	Row Address : RA0 ~ RA10, Column Address : CA0 ~ CA7 Auto-precharge flag : A10
$\overline{\text{RAS}}$, $\overline{\text{CAS}}$, $\overline{\text{WE}}$	Row Address Strobe, Column Address Strobe, Write Enable	$\overline{\text{RAS}}$, $\overline{\text{CAS}}$ and $\overline{\text{WE}}$ define the operation. Refer function truth table for details
LDQM, UDQM	Data Input/Output Mask	DQM control output buffer in read mode and mask input data in write mode
DQ0 ~ DQ15	Data Input/Output	Multiplexed data input / output pin
VDD/VSS	Power Supply/Ground	Power supply for internal circuit and input buffer
VDDQ/VSSQ	Data Output Power/Ground	Power supply for DQ
NC	No Connection	No connection

FUNCTIONAL BLOCK DIAGRAM

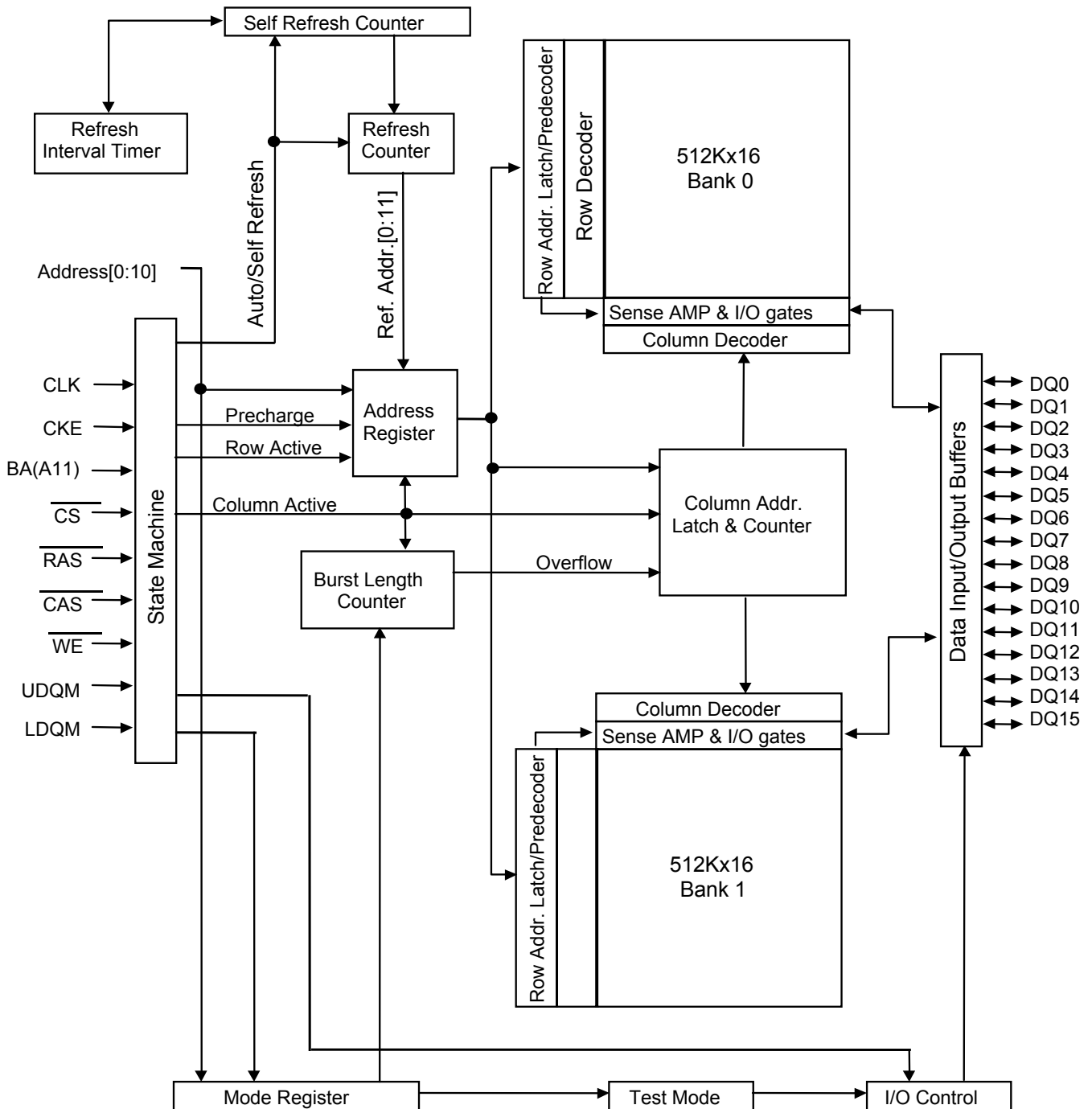
1Mx16 Synchronous DRAM



ABSOLUTE MAXIMUM RATINGS

Parameter	Symbol	Rating	Unit
Ambient Temperature	TA	0 ~ 70	°C
Storage Temperature	TSTG	-55 ~ 125	°C
Voltage on Any Pin relative to VSS	VIN, VOUT	-1.0 ~ 4.6	V
Voltage on VDD relative to VSS	VDD	-1.0 ~ 4.6	V
Short Circuit Output Current	IOS	50	mA
Power Dissipation	PD	1	W
Soldering Temperature-Time	TSOLDER	260-10	°C ·Sec

Note : Operation at above absolute maximum rating can adversely affect device reliability.

DC OPERATING CONDITION (TA=0°C to 70°C)

Parameter	Symbol	Min	Typ.	Max	Unit	Note
Power Supply Voltage	VDD, VDDQ	3.0	3.3	3.6	V	1, 2, 3
Input high voltage	VIH	2.0	3.0	VDD + 0.3	V	1, 4
Input low voltage	VIL	-0.3	0	0.8	V	1, 5

Note :

- All voltages are referenced to VSS = 0V.
- VDD(min) is 3.15V when HY57V161610ETP-7 operates at $\overline{\text{CAS}}$ latency=2
- VDD(min) of HY57V161610ETP-5/55 is 3.15V
- Vih(Max) : 4.6V AC pulse width with < 3ns of duration.
- Vil(min) : -1.5V AC pulse width with < 3ns of duration.

AC OPERATING CONDITION (TA=0°C to 70°C, VDD=3.0V to 3.6V, VSS=0V)

Parameter	Symbol	Value	Unit	Note
AC input high / low level voltage	VIH / VIL	2.4/0.4	V	
Input timing measurement reference level voltage	Vtrip	1.4	V	
Input rise / fall time	tR / tF	1	ns	
Output timing measurement reference level	Voutref	1.4	V	
Output load capacitance for access time measurement	CL	30	pF	1

Note :

- Output load to measure access times is equivalent to two TTL gates and one capacitance(30pF).
For details, refer to AC/DC output load circuit.
- VDD(min) is 3.15V when HY57V161610ETP-7 operates at $\overline{\text{CAS}}$ latency=2 and tCK2=8.9ns
- VDD(min) of HY57V161610ETP-5/55 is 3.15V'

CAPACITANCE (TA=25°C, f=1MHz)

Parameter	Pin	Symbol	Min	Max	Unit
Input capacitance	CLK	C11	2.5	4	pF
	A0 ~ A10, BA, CKE, CS, RAS, CAS, WE, UDQM, LDQM	C12	2.5	5	pF
Data input / output capacitance	DQ0 ~ DQ15	C1/O	4	6.5	pF

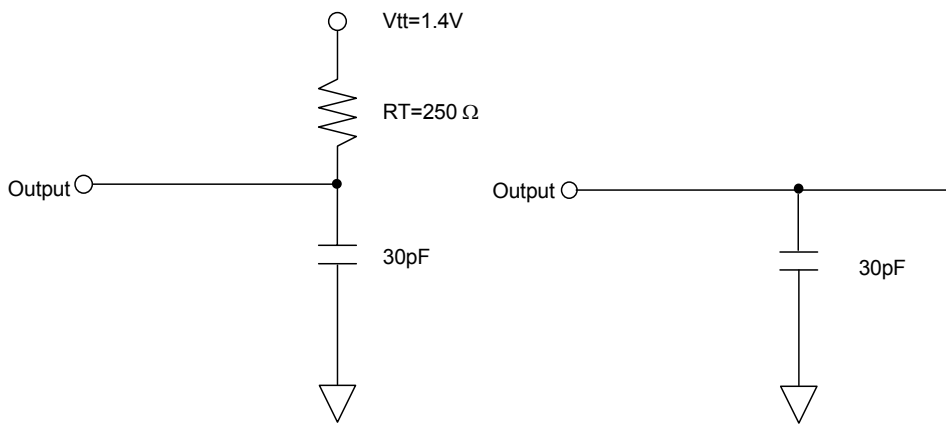
OUTPUT LOAD CIRCUIT

DC Output Load Circuit

AC Output Load Circuit

DC CHARACTERISTICS I (TA=0°C to 70°C)

Parameter	Symbol	Min.	Max	Unit	Note
Power Supply Voltage	VDD	3.0	3.6	V	1, 2
Input leakage current	IL	-1	1	uA	3
Output leakage current	IO	-1	1	uA	4
Output high voltage	VOH	2.4	-	V	IOH = -4mA
Output low voltage	VOL	-	0.4	V	IOL = +4mA

Note :

- VDD(min) is 3.15V when HY57V161610ETP-7 operates at CAS latency=2 and tCK2=8.9ns.
- VDD(min) of HY57V161610ETP-5/55 is 3.15V
- VIN = 0 to 3.6V, All other pins are not under test = 0V
- DOUT is disabled, VOUT=0 to 3.6V

DC CHARACTERISTICS II (TA=0°C to 70°C, VDD=3.0V to 3.6V, VSS=0V^{Note1,2})

Parameter	Symbol	Test Condition	Speed							Unit	Note	
			-5	-55	-6	-7	-8	-10	-15			
Operating Current	IDD1	Burst Length=1, One bank active tRAS ≥ tRAS(min), tRP ≥ tRP(min), IO=0mA	130	130	120	110	110	110	100	mA	2	
Precharge Standby Current in power down mode	IDD2P	CKE ≤ VIL(max), tCK = 15ns	2							mA		
	IDD2PS	CKE ≤ VIL(max), tCK = ∞	1									
Precharge Standby Current in non power down mode	IDD2N	CKE ≥ VIH(min), \overline{CS} ≥ VIH(min), tCK = 15ns Input signals are changed one time during 2Clks. All other pins ≥ VDD-0.2V or ≤ 0.2V	25							mA		
	IDD2NS	CKE ≥ VIH(min), tCK = ∞ Input signals are stable.	15									
Active Standby Current in power down mode	IDD3P	CKE ≤ VIL(max), tCK = min	3.0							mA		
	IDD3PS	CKE ≤ VIL(max), tCK = ∞	3.0									
Active Standby Current in non power down mode	IDD3N	CKE ≥ VIH(min), \overline{CS} ≥ VIH(min), tCK = min Input signals are changed one time during 2CLKs. All other pins ≥ VDD-0.2V or ≤ 0.2V	50							mA		
	IDD3NS	CKE ≥ VIH(min), tCK = ∞ Input signals are stable	30									
Burst Mode Operating Current	IDD4	tCK ≥ tCK(min), tRAS ≥ tRAS(min), IO=0mA All banks active	CL=3	130	130	120	110	110	90	80	mA	3
			CL=2	-	-	110	110	-	-	-		
			CL=1	-	-	-	-	-	-	70		
Auto Refresh Current	IDD5	tRRC ≥ tRRC(min), All banks active	130	130	110	110	110	110	100	mA		
Self Refresh Current	IDD6	CKE ≤ 0.2V	2							mA		

Note :

- VDD(min) is 3.15V when HY57V161610ETP-7 operates at \overline{CAS} latency=2 and tCK2=8.9ns.
- VDD(min) of HY57V161610ETP-5/55 is 3.15V
- IDD1 and IDD4 depend on output loading and cycle rates. Specified values are measured with the output open.

AC CHARACTERISTICS (TA=0°C to 70°C, VDD=3.0V to 3.6V, VSS=0V^{Note1,2})

Parameter		Symbol	-5		-55		-6		-7		Unit	Note
			Min	Max	Min	Max	Min	Max	Min	Max		
System clock cycle time	CL=3	tCK3	5		5.5		6	-	7	-	ns	3
	CL=2	tCK2	-		-		10	-	10	-		
	CL=1	tCK1	-		-		-	-	-	-		
Clock high pulse width		tCHW	2		2		2	-	2.5	-	ns	4
Clock low pulse width		tCLW	2		2		2	-	2.5	-	ns	4
Access time from clock	CL=3	tAC3		4.5		5	-	5.5	-	6	ns	3
	CL=2	tAC2					-	6	-	6		
	CL=1	tAC1					-	-	-	-		
Data-out hold time		tOH	1.5		2		2	-	2.5	-	ns	
Data-Input setup time		tDS	1.5		1.5		1.5	-	1.75	-	ns	4
Data-Input hold time		tDH	1		1		1	-	1	-	ns	4
Address setup time		tAS	1.5		1.5		1.5	-	1.75	-	ns	4
Address hold time		tAH	1		1		1	-	1	-	ns	4
CKE setup time		tCKS	1.5		1.5		1.5	-	1.75	-	ns	4
CKE hold time		tCKH	1		1		1	-	1	-	ns	4
Command setup time		tCS	1.5		1.5		1.5	-	1.75	-	ns	4
Command hold time		tCH	1		1		1	-	1	-	ns	4
CLK to data output in low Z-time		tOLZ	2		2		2	-	2	-	ns	
CLK to data output in high Z-time		tOHZ	2	5	2	5.5	2	6	2	7	ns	

AC CHARACTERISTICS (TA=0°C to 70°C, VDD=3.0V to 3.6V, VSS=0V^{Note1,2})

- continued -

Parameter		Symbol	-8		-10		-15		Unit	Note
			Min	Max	Min	Max	Min	Max		
System clock cycle time	CL=3	tCK3	8	-	10	-	15	-	ns	3
	CL=2	tCK2	12	-	12	-	15	-		
	CL=1	tCK1	-	-	-	-	15	-		
Clock high pulse width		tCHW	3	-	3	-	3	-	ns	4
Clock low pulse width		tCLW	3	-	3	-	3	-	ns	4
Access time from clock	CL=3	tAC3	-	6	-	7	-	7	ns	3
	CL=2	tAC2	-	6	-	7	-	7		
	CL=1	tAC1	-	-	-	-	-	14		
Data-out hold time		tOH	2.5	-	2.5	-	2.5	-	ns	
Data-Input setup time		tDS	2	-	2.5	-	2.5	-	ns	4
Data-Input hold time		tDH	1	-	1	-	1	-	ns	4
Address setup time		tAS	2	-	2.5	-	2.5	-	ns	4
Address hold time		tAH	1	-	1	-	1	-	ns	4
CKE setup time		tCKS	2	-	2.5	-	2.5	-	ns	4
CKE hold time		tCKH	1	-	1	-	1	-	ns	4
Command setup time		tCS	2	-	2.5	-	2.5	-	ns	4
Command hold time		tCH	1	-	1	-	1	-	ns	4
CLK to data output in low Z-time		tOLZ	2	-	2	-	2	-	ns	
CLK to data output in high Z-time		tOHZ	2	8	3	10	3	15	ns	

Note :

- 1.VDD(min) is 3.15V when HY57V161610ETP-7 operates at $\overline{\text{CAS}}$ latency=2 and tCK2=8.9ns.
- 2.VDD(min) of HY57V161610ETP-5/55 is 3.15V
- 3.tCK2 is 8.9ns only when tAC2 is 7.9ns in HY57V161610ET-6 and HY57V161610ETP-7.
- 4.Assume tR / tF (input rise and fall time) is 1ns.

AC CHARACTERISTICS (TA=0°C to 70°C, VDD=3.0V to 3.6V, VSS=0V^{Note1,2})

Paramter		Symbol	-5		-55		-6		-7		Unit	Note
			Min	Max	Min	Max	Min	Max	Min	Max		
$\overline{\text{RAS}}$ cycle time	Operation	tRC	55		55		60	-	70	-	ns	
	Auto Refresh	tRRC	55		55		60	-	70	-	ns	
$\overline{\text{RAS}}$ to $\overline{\text{CAS}}$ delay		tRCD	15		16.5		18	-	20	-	ns	
$\overline{\text{RAS}}$ active time		tRAS	40	100K	38.5	100K	40	100K	45	100K	ns	
$\overline{\text{RAS}}$ precharge time		tRP	3		3		3	-	3	-	CLK	
$\overline{\text{RAS}}$ to $\overline{\text{RAS}}$ bank active delay		tRRD	2		2		2	-	2	-	CLK	
$\overline{\text{CAS}}$ to $\overline{\text{CAS}}$ bank active delay		tCCD	1		1		1	-	1	-	CLK	
Write command to data-in delay		tWTL	0		0		0	-	0	-	CLK	
Data-in to precharge command		tDPL	1		1		1	-	1	-	CLK	
Data-in to active command		tDAL	5		4		4	-	4	-	CLK	
DQM to data-in Hi-Z		tDQZ	2		2		2	-	2	-	CLK	
DQM to data mask		tDQM	0		0		0	-	0	-	CLK	
MRS to new command		tMRD	2		2		2	-	2	-	CLK	
Precharge to data output Hi-Z		tPROZ	3		3		3	-	3	-	CLK	
Power down exit time		tPDE	1		1		1	-	1	-	CLK	
Self refresh exit time		tSRE	1		1		1	-	1	-	CLK	3
Refresh Time		tREF		64		64	-	64	-	64	ms	

AC CHARACTERISTICS (TA=0°C to 70°C, VDD=3.0V to 3.6V, VSS=0V^{Note1,2})

- continued

Paramter		Symbol	-8		-10		-15		Unit	Note
			Min	Max	Min	Max	Min	Max		
$\overline{\text{RAS}}$ cycle time	Operation	tRC	70	-	70	-	70	-	ns	
	Auto Refresh	tRRC	70	-	80	-	80	-	ns	
$\overline{\text{RAS}}$ to $\overline{\text{CAS}}$ delay		tRCD	20	-	20	-	20	-	ns	
$\overline{\text{RAS}}$ active time		tRAS	45	100K	45	100K	45	100K	ns	
$\overline{\text{RAS}}$ precharge time		tRP	3	-	2	-	2	-	CLK	
$\overline{\text{RAS}}$ to $\overline{\text{RAS}}$ bank active delay		tRRD	2	-	2	-	2	-	CLK	
$\overline{\text{CAS}}$ to $\overline{\text{CAS}}$ bank active delay		tCCD	1	-	1	-	1	-	CLK	
Write command to data-in delay		tWTL	0	-	0	-	0	-	CLK	
Data-in to precharge command		tDPL	1	-	1	-	1	-	CLK	
Data-in to active command		tDAL	4	-	3	-	3	-	CLK	
DQM to data-in Hi-Z		tDQZ	2	-	2	-	2	-	CLK	
DQM to data mask		tDQM	0	-	0	-	0	-	CLK	
MRS to new command		tMRD	2	-	2	-	2	-	CLK	
Precharge to data output Hi-Z		tPROZ	3	-	3	-	3	-	CLK	
Power down exit time		tPDE	1	-	1	-	1	-	CLK	
Self refresh exit time		tSRE	1	-	1	-	1	-	CLK	3
Refresh Time		tREF	-	64	-	64	-	64	ms	

- Note :
1. VDD(min) is 3.15V when HY57V161610ETP-7 operates at $\overline{\text{CAS}}$ latency=2 and tCK2=8.9ns.
 2. VDD(min) of HY57V161610ETP-5/55 is 3.15V
 3. A new command can be given tRRC after self refresh exit.

DEVICE OPERATING OPTION TABLE
HY57V161610ETP-5

	$\overline{\text{CAS}}$ Latency	tRCD	tRAS	tRC	tRP	tAC	tOH
200MHz	3CLKs	3CLKs	8CLKs	11CLKs	3CLKs	4.5ns	1.5ns
183MHz	3CLKs	3CLKs	7CLKs	10CLKs	3CLKs	5ns	2ns
166MHz	3CLKs	3CLKs	7CLKs	10CLKs	3CLKs	5.5ns	2ns

HY57V161610ETP-55

	CAS Latency	tRCD	tRAS	tRC	tRP	tAC	tOH
183MHz	3CLKs	3CLKs	7CLKs	10CLKs	3CLKs	5ns	2ns
166MHz	3CLKs	3CLKs	7CLKs	10CLKs	3CLKs	5.5ns	2ns
143MHz	3CLKs	3CLKs	7CLKs	10CLKs	3CLKs	5.5ns	2.5ns

HY57V161610ETP-6

	CAS Latency	tRCD	tRAS	tRC	tRP	tAC	tOH
166MHz	3CLKs	3CLKs	7CLKs	10CLKs	3CLKs	5.5ns	2ns
143MHz	3CLKs	3CLKs	7CLKs	10CLKs	3CLKs	5.5ns	2.5ns
125MHz	3CLKs	2CLKs	6CLKs	9CLKs	3CLKs	6ns	2.5ns

HY57V161610ETP-7

	CAS Latency	tRCD	tRAS	tRC	tRP	tAC	tOH
143MHz	3CLKs	3CLKs	7CLKs	10CLKs	3CLKs	5.5ns	2.5ns
125MHz	3CLKs	3CLKs	6CLKs	9CLKs	3CLKs	6ns	2.5ns
100MHz	2CLKs	2CLKs	5CLKs	7CLKs	2CLKs	7ns	2.5ns

HY57V161610ETP-8

	CAS Latency	tRCD	tRAS	tRC	tRP	tAC	tOH
125MHz	3CLKs	3CLKs	6CLKs	9CLKs	3CLKs	6ns	2.5ns
100MHz	3CLKs	2CLKs	5CLKs	7CLKs	2CLKs	7ns	2.5ns
83MHz	2CLKs	2CLKs	4CLKs	6CLKs	2CLKs	7ns	2.5ns

HY57V161610ETP-10

	CAS Latency	tRCD	tRAS	tRC	tRP	tAC	tOH
100MHz	3CLKs	2CLKs	5CLKs	7CLKs	2CLKs	7ns	2.5ns
83MHz	2CLKs	2CLKs	4CLKs	6CLKs	2CLKs	7ns	2.5ns

HY57V161610ETP-15

	CAS Latency	tRCD	tRAS	tRC	tRP	tAC	tOH
66MHz	1CLKs	2CLKs	4CLKs	6CLKs	2CLKs	14ns	2.5ns

COMMAND TRUTH TABLE

Command		CKEn-1	CKEn	\overline{CS}	\overline{RAS}	\overline{CAS}	\overline{WE}	DQM	A0~A9	A10/AP	BA	Note
Mode Register Set		H	X	L	L	L	L	X	OP code			
No Operation		H	X	H	X	X	X	X	X			
				L	H	H	H					
Bank Active		H	X	L	L	H	H	X	Row Address		V	
Read		H	X	L	H	L	H	X	Column Address	L	V	
Read with Auto precharge										H		
Write		H	X	L	H	L	L	X	Column Address	L	V	
Write with Auto precharge										H		
Precharge All Bank		H	X	L	L	H	L	X	X	H	X	
Precharge selected Bank										L	V	
Burst Stop		H	X	L	H	H	L	X	X			
U/LDQM		H	X					V	X			
Auto Refresh		H	H	L	L	L	H	X	X			
Burst-READ-Single-WRITE		H	X	L	L	L	L	X	A9 Pin High (Other Pins OP code)			
Self Refresh ¹	Entry	H	L	L	L	L	H	X	X			
	Exit	L	H	H	X	X	X	X				
Precharge power down	Entry	H	L	H	X	X	X	X	X			
				L	H	H	H					
	Exit	L	H	H	X	X	X	X				
				L	H	H	H					
Clock Suspend	Entry	H	L	H	X	X	X	X	X			
	Exit			L	H	X						

Note :

1. Exiting Self Refresh occurs by asynchronously bringing CKE from low to high.
2. X=Do not care, L=Low, H=High, BA=Bank Address, RA= Row Address, CA=Column Address, Opcode=Operand Code, NOP=No Operation.

PACKAGE INFORMATION

400mil 50pin Thin Small Outline Package (TC)
1Mx16 Synchronous DRAM

UNIT : mm(inch)

