

APTR3216EC HIGH EFFICIENCY RED
 APTR3216SGC SUPER BRIGHT GREEN
 APTR3216YC YELLOW

Features

- 3.2mmx1.6mm SMT LED, 1.05mm THICKNESS.
- LOW POWER CONSUMPTION.
- WIDE VIEWING ANGLE.
- IDEAL FOR BACKLIGHT AND INDICATOR.
- VARIOUS COLORS AND LENS TYPES AVAILABLE.
- PACKAGE : 2000PCS / REEL.

Description

The High Efficiency Red source color devices are made with Gallium Arsenide Phosphide on Gallium Phosphide Orange Light Emitting Diode.

The Super Bright Green source color devices are made with Gallium Phosphide Green Light Emitting Diode.

The Yellow source color devices are made with Gallium Arsenide Phosphide on Gallium Phosphide Yellow Light Emitting Diode.

Package Dimensions

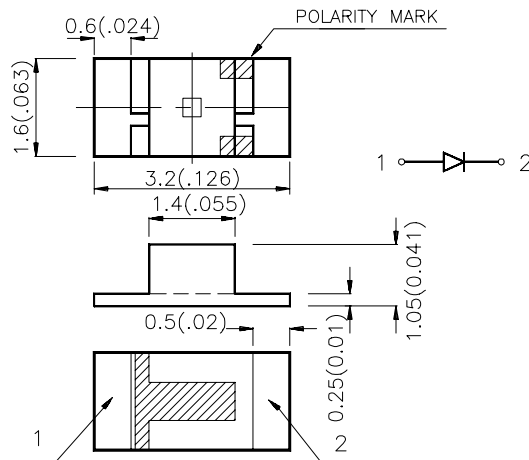

Notes:

1. All dimensions are in millimeters (inches).
2. Tolerance is ± 0.2 (0.0079") unless otherwise noted.
3. Lead spacing is measured where the lead emerge package.
4. Specifications are subject to change without notice.

Selection Guide

Part No.	Dice	Lens Type	Iv (mcd) @ 20 mA		Viewing Angle
			Min.	Typ.	θ1/2
APTR3216EC	HIGH EFFICIENCY RED(GaAsP/GaP)	WATER CLEAR	5	12	120°
APTR3216SGC	SUPER BRIGHT GREEN (GaP)	WATER CLEAR	3	12	120°
APTR3216YC	YELLOW (GaAsP/GaP)	WATER CLEAR	1.6	8	120°

Note:

1. θ1/2 is the angle from optical centerline where the luminous intensity is 1/2 the optical centerline value.

Electrical / Optical Characteristics at T_A=25°C

Symbol	Parameter	Device	Typ.	Max.	Units	Test Conditions
λ _{peak}	Peak Wavelength	High Efficiency Red Super Bright Green Yellow	627 565 590		nm	IF=20mA
λ _D	Dominate Wavelength	High Efficiency Red Super Bright Green Yellow	625 568 588		nm	IF=20mA
Δλ _{1/2}	Spectral Line Halfwidth	High Efficiency Red Super Bright Green Yellow	45 30 35		nm	IF=20mA
C	Capacitance	High Efficiency Red Super Bright Green Yellow	15 15 20		pF	VF=0V;f=1MHz
V _F	Forward Voltage	High Efficiency Red Super Bright Green Yellow	2.0 2.2 2.1	2.5 2.5 2.5	V	IF=20mA
I _R	Reverse Current	High Efficiency Red Super Bright Green Yellow		10	μA	VR = 5V

Absolute Maximum Ratings at T_A=25°C

Parameter	High Efficiency red	Super Bright Green	Yellow	Units
Power dissipation	105	105	105	mW
DC Forward Current	30	25	30	mA
Peak Forward Current [1]	160	140	140	mA
Reverse Voltage	5	5	5	V
Operating Temperature	-40°C To +85°C			
Storage Temperature	-40°C To +85°C			

Note:

1. 1/10 Duty Cycle, 0.1ms Pulse Width.

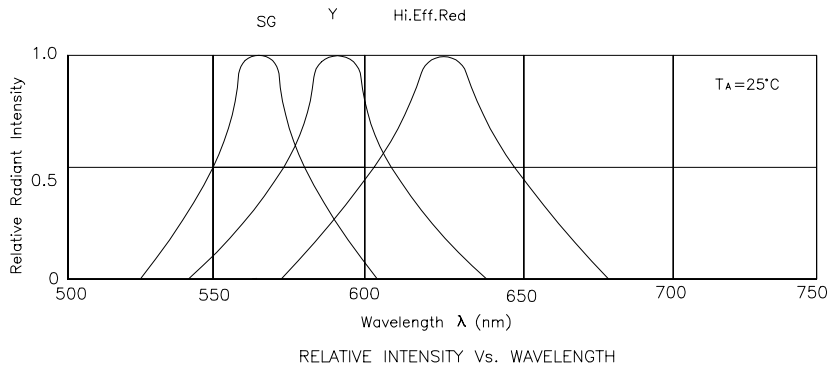

High Efficiency Red APTR3216EC

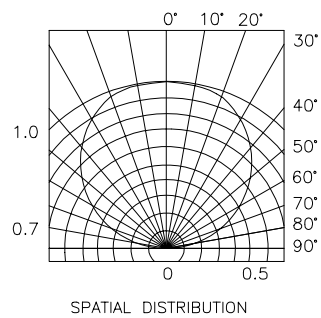
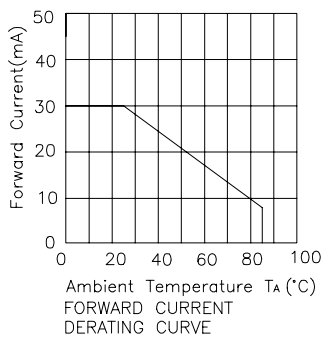
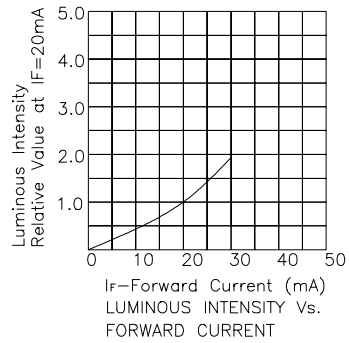
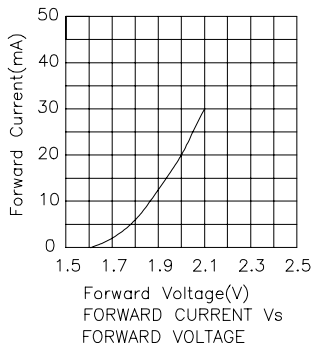

Super Bright Green APTR3216SGC

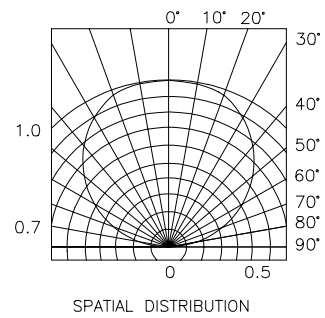
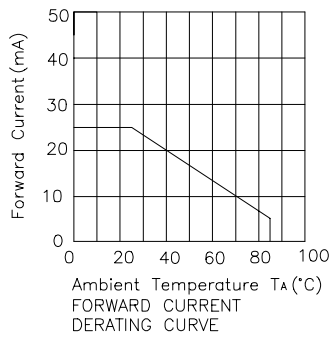
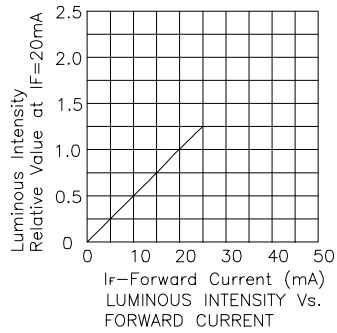
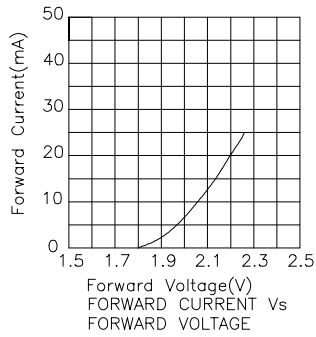

Yellow APTR3216YC

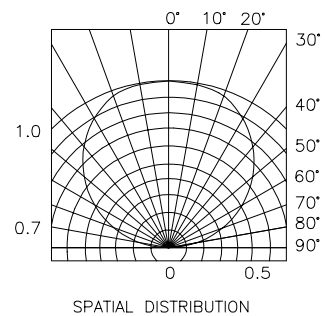
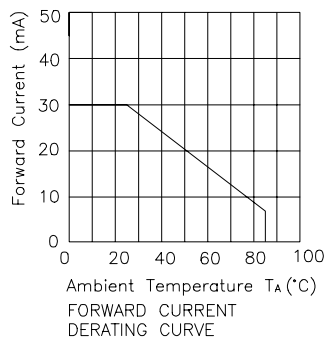
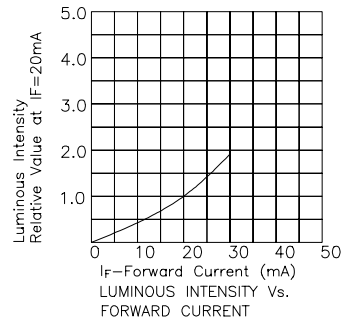
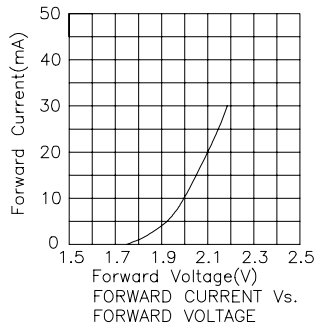

APTR3216 SMT Reflow Soldering Instructions

Number of reflow process shall be less than 2 times and cooling process to normal temperature is required between first and second soldering process.

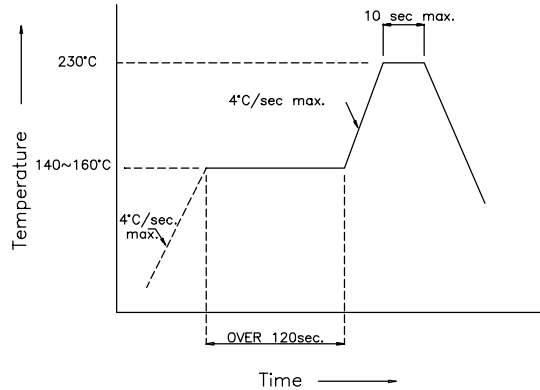

Recommended Soldering Pattern (Units : mm)

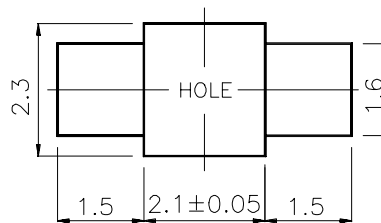

Tape Specifications (Units : mm)

