



# BAT400D

## 0.5A Surface Mount Schottky Barrier Rectifier



Voltage Range  
40 Volts  
480m Watts Power Dissipation

### SOT-23

### Features

- ✧ Low forward voltage drop
- ✧ High conductance

### Mechanical Data

- ✧ Case: SOT-23, Molded plastic
- ✧ Terminals: Solderable per MIL-STD-202, Method 208
- ✧ Polarity: See diagram
- ✧ Marking: KSJ
- ✧ Weight: 0.008 grams (approx.)

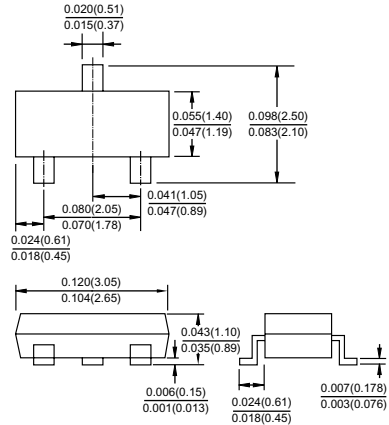

### Maximum Ratings and Electrical Characteristics

Rating at 25°C ambient temperature unless otherwise specified.

#### Maximum Ratings

Type Number	Symbol	BAT400D	Units
Peak Repetitive Reverse Voltage	VRRM		
Working Peak Reverse Voltage	VRWM	40	V
DC Blocking Voltage	VR		
RMS Reverse Voltage	VR(RMS)	28	V
Average Rectified Current	Io	0.5	A
Non-repetitive Peak Forward Surge Current 8.3ms Single half Sine-Wave Superimposed on Rated Load (JEDEC Method)	IFSM	3	A
Power Dissipation (see figure 1)	Pd	480	mW
Thermal Resistance Junction to Ambient Air (Note 1)	RθJA	286	°C/W
Operating and Storage Temperature Range	TJ, TSTG	-40 to + 125	°C

#### Electrical Characteristics

Type Number	Symbol	Min	Typ	Max	Units
Reverse Breakdown Voltage IR=1mA	V(BR)	40	-	-	V
Reverse Leakage Current (Note 2) VR=10V	IR	--	1.0	30	uA
VR=30V		--	2.0	50	uA
Forward Voltage Drop (Note 2) IF=10mA	VF	-	285	300	mV
IF=500mA		-	480	550	mV
Junction Capacitance VR=0, f=1.0MHz	Cj	-	125	-	pF
VR=10, f=1.0MHz		-	20	-	pF

- Notes: 1. Valid Provided that Terminals are Kept at Ambient Temperature.  
2. Short Duration Pulse Test used to Minimize Self-Heating Effect..

## RATINGS AND CHARACTERISTIC CURVES (BAT400D)

FIG.1- POWER DERATING CURVE

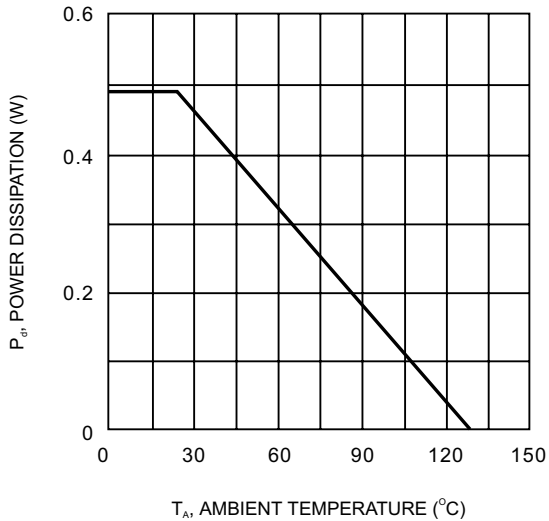

FIG.2- TYPICAL FWD CHARACTERISTICS

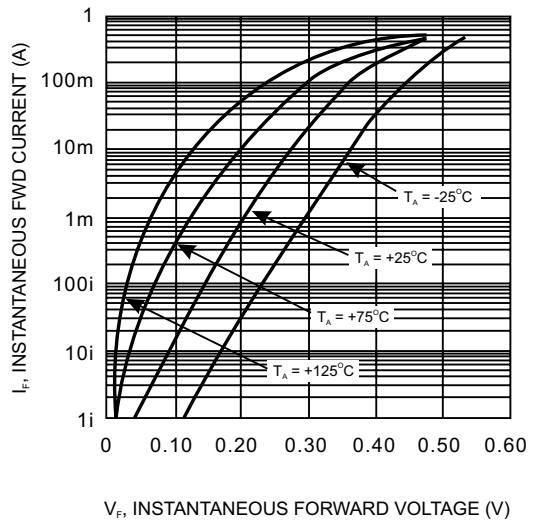

FIG.3- TYPICAL REVERSE CHARACTERISTICS

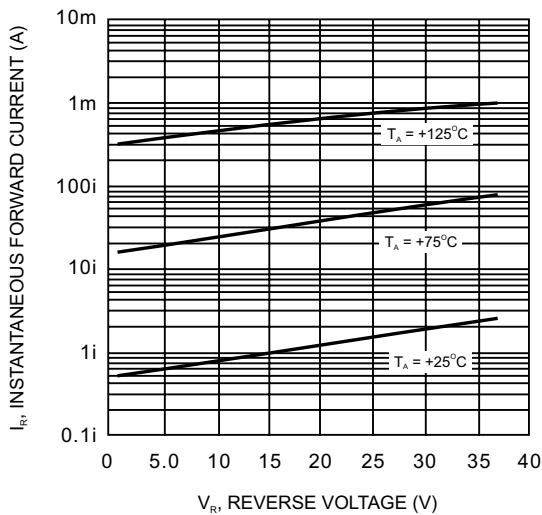

FIG.4- TYPICAL JUNCTION CAPACITANCE VS REVERSE VOLTAGE

