



# BAV23S

## Surface Mount Switching Diode



Voltage Range  
200 Volts  
350m Watts Power Dissipation

### Features

- ✧ Fast switching speed
- ✧ Surface mount package ideally suited for automatic insertion
- ✧ For general purpose switching applications
- ✧ High conductance

### Mechanical Data

- ✧ Case: SOT-23, Molded plastic
- ✧ Terminals: Solderable per MIL-STD-202, Method 208
- ✧ Polarity: See diagram
- ✧ Marking: KL31
- ✧ Weight: 0.008 gram (approx.)

### SOT-23

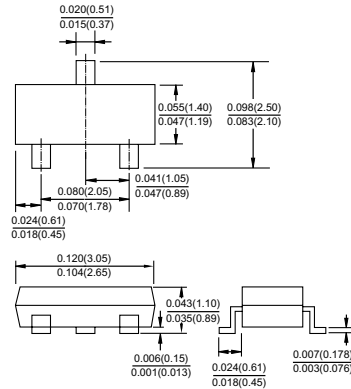

### Maximum Ratings and Electrical Characteristics

Rating at 25°C ambient temperature unless otherwise specified.

#### Maximum Ratings

Type Number	Symbol	BAV23S	Units
Repetitive Peak Reverse Voltage	VRRM	250	V
Working Peak Reverse Voltage	VRWM	200	V
DC Blocking Voltage	VR		V
RMS Reverse Voltage	VR(RMS)	141	V
Forward Continuous Current (Note 1)	IFM	400	mA
Average Rectifier Output Current (Note 1)	Io	200	mA
Non-Repetitive Peak Forward Surge Current @ t=1.0uS @ t=100uS @ t=10mS	IFSM	9.0 3.0 1.7	A
Repetitive Peak Forward Surge Current	IFRM	625	mA
Power Dissipation (Note 1)	Pd	350	mW
Thermal Resistance Junction to Ambient Air (Note 1)	RθJA	357	K/W
Operating and Storage Temperature Range	TJ, TSTG	-65 to + 150	°C

#### Electrical Characteristics

Type Number	Symbol	Min	Max	Units
Forward Voltage IF=100mA IF= 200mA	VF	-	1.0 1.25	V
Peak Reverse Current Tj=25 °C Tj=100°C	IR	-	100 100	nA uA
Junction Capacitance VR=0, f=1.0MHz	Cj	-	5.0	pF
Reverse Recovery Time (Note 2)	trr	-	50	nS

Notes: 1. Valid Provided that Terminals are Kept at Ambient Temperature.

2. Reverse Recovery Test Conditions: IF=IR=10mA, Irr=0.1 x IR, RL=100Ω.

## RATINGS AND CHARACTERISTIC CURVES (BAV23S)

FIG.1- FORWARD CHARACTERISTICS

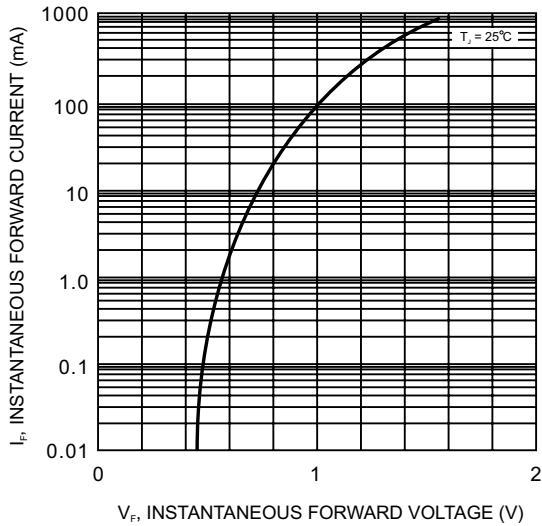

FIG.2- LEAKAGE CURRENT VS JUNCTION TEMPERATURE

