



# SB305 THRU SB3100

## Single Phase 3.0 AMPS. Silicon Bridge Rectifiers



Voltage Range  
50 to 1000 Volts  
Current  
3.0 Amperes

### Features

- ✧ UL Recognized File # E-96005
- ✧ High surge current capability
- ✧ Low forward voltage drop
- ✧ High temperature soldering guaranteed:  
260°C / 10 seconds / 0.375" ( 9.5mm )  
lead length at 5 lbs., ( 2.3 kg ) tension
- ✧ Small size, simple installation
- ✧ Leads solderable per MIL-STD-202,  
Method 208

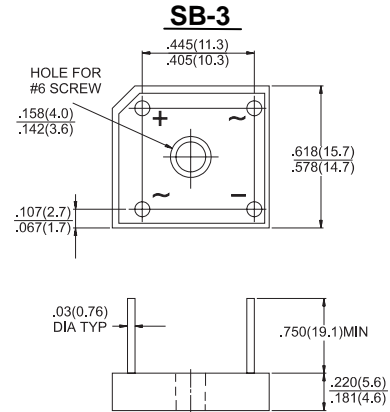

Dimensions in inches and (millimeters)

### Maximum Ratings and Electrical Characteristics

Rating at 25°C ambient temperature unless otherwise specified.

Single phase, half wave, 60 Hz, resistive or inductive load.

For capacitive load, derate current by 20%

Type Number	Symbol	SB 305	SB 310	SB 320	SB 340	SB 360	SB 380	SB 3100	Units
Maximum Recurrent Peak Reverse Voltage	$V_{RRM}$	50	100	200	400	600	800	1000	V
Maximum RMS Voltage	$V_{RMS}$	35	70	140	280	420	560	700	V
Maximum DC Blocking Voltage	$V_{DC}$	50	100	200	400	600	800	1000	V
Maximum Average Forward Rectified Current @ $T_A = 50^\circ\text{C}$	$I_{(AV)}$	3.0							A
Peak Forward Surge Current, 8.3 ms Single Half Sine-wave Superimposed on Rated Load (JEDEC method)	$I_{FSM}$	60							A
Maximum Instantaneous Forward Voltage @ 1.5A	$V_F$	1.1							V
Maximum DC Reverse Current @ $T_A=25^\circ\text{C}$ at Rated DC Blocking Voltage @ $T_A=100^\circ\text{C}$	$I_R$	10 500							$\mu\text{A}$ $\mu\text{A}$
Typical Thermal Resistance (Note)	$R_{\theta_{JC}}$	10							$^\circ\text{C}/\text{W}$
Operating Temperature Range	$T_J$	-55 to +125							$^\circ\text{C}$
Storage Temperature Range	$T_{STG}$	-55 to +150							$^\circ\text{C}$

Note: Thermal Resistance from Junction to Case per Leg.

## RATINGS AND CHARACTERISTIC CURVES (SB305 THRU SB3100)

