

# RF LDMOS Wideband Integrated Power Amplifiers

The MW4IC915MB/GMB wideband integrated circuit is designed for GSM and GSM EDGE base station applications. It uses Freescale's newest High Voltage (26 to 28 Volts) LDMOS IC technology and integrates a multi-stage structure. Its wideband On-Chip design makes it usable from 750 to 1000 MHz. The linearity performances cover all modulations for cellular applications: GSM, GSM EDGE, TDMA, N-CDMA and W-CDMA.

### Final Application

- Typical Performance:  $V_{DD} = 26$  Volts,  $I_{DQ1} = 60$  mA,  $I_{DQ2} = 240$  mA,  $P_{out} = 15$  Watts CW, Full Frequency Band (860-960 MHz)  
 Power Gain — 30 dB  
 Power Added Efficiency — 44%

### Driver Application

- Typical GSM/GSM EDGE Performances:  $V_{DD} = 26$  Volts,  $I_{DQ1} = 60$  mA,  $I_{DQ2} = 240$  mA,  $P_{out} = 3$  Watts Avg., Full Frequency Band (869-894 MHz and 921-960 MHz)  
 Power Gain — 31 dB  
 Power Added Efficiency — 19%  
 Spectral Regrowth @ 400 kHz Offset = -65 dBc  
 Spectral Regrowth @ 600 kHz Offset = -83 dBc  
 EVM — 1.5%
- Capable of Handling 5:1 VSWR, @ 26 Vdc, 921 MHz, 15 Watts CW Output Power
- Characterized with Series Equivalent Large-Signal Impedance Parameters
- On-Chip Matching (50 Ohm Input, DC Blocked, >3 Ohm Output)
- Integrated Quiescent Current Temperature Compensation with Enable/Disable Function
- On-Chip Current Mirror  $g_m$  Reference FET for Self Biasing Application<sup>(1)</sup>
- Integrated ESD Protection
- Also Available in Gull Wing for Surface Mount
- In Tape and Reel. R1 Suffix = 500 Units per 44 mm, 13 inch Reel.

## MW4IC915MBR1 MW4IC915GMBR1

**860 - 960 MHz, 15 W, 26 V  
 GSM/GSM EDGE, N-CDMA  
 RF LDMOS WIDEBAND  
 INTEGRATED POWER AMPLIFIERS**

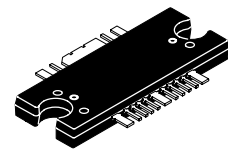

**CASE 1329-09  
 TO-272 WB-16  
 PLASTIC  
 MW4IC915MBR1**

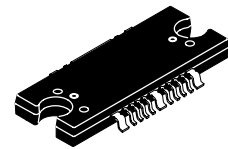

**CASE 1329A-03  
 TO-272 WB-16 GULL  
 PLASTIC  
 MW4IC915GMBR1**

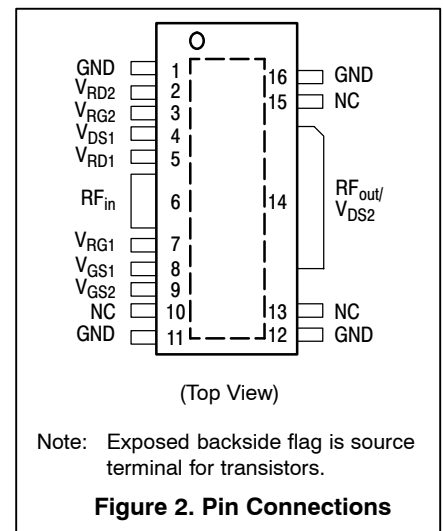
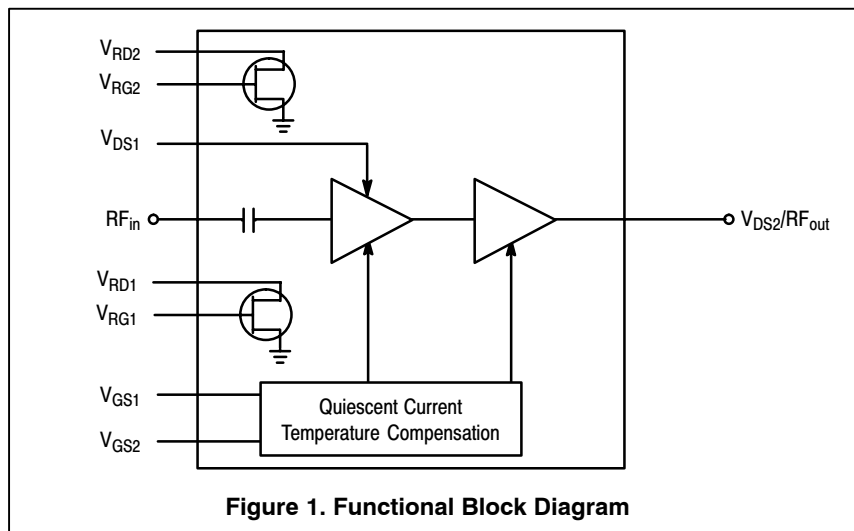

1. Refer to AN1987/D, *Quiescent Current Control for the RF Integrated Circuit Device Family*. Go to <http://www.freescale.com/rf>. Select Documentation/Application Notes - AN1987.

**Table 1. Maximum Ratings**

Rating	Symbol	Value	Unit
Drain-Source Voltage	$V_{DSS}$	-0.5. +65	Vdc
Gate-Source Voltage	$V_{GS}$	-0.5. +15	Vdc
Storage Temperature Range	$T_{stg}$	-65 to +175	°C
Operating Junction Temperature	$T_J$	200	°C

**Table 2. Thermal Characteristics**

Characteristic	Symbol	Value (1)	Unit
Thermal Resistance, Junction to Case	$R_{\theta JC}$		°C/W
GSM Application ( $P_{out} = 15$ W CW)	Stage 1, 26 Vdc, $I_{DQ} = 60$ mA Stage 2, 26 Vdc, $I_{DQ} = 240$ mA	7.3 1.7	
GSM EDGE Application ( $P_{out} = 7.5$ W CW)	Stage 1, 26 Vdc, $I_{DQ} = 60$ mA Stage 2, 26 Vdc, $I_{DQ} = 240$ mA	7.3 1.8	
CDMA Application ( $P_{out} = 3.75$ W CW)	Stage 1, 26 Vdc, $I_{DQ} = 60$ mA Stage 2, 26 Vdc, $I_{DQ} = 240$ mA	7.4 1.9	

**Table 3. ESD Protection Characteristics**

Test Conditions	Class
Human Body Model	1 (Minimum)
Machine Model	M3 (Minimum)
Charge Device Model	C2 (Minimum)

**Table 4. Moisture Sensitivity Level**

Test Methodology	Rating	Package Peak Temperature	Unit
Per JESD 22-A113D, IPC/JEDEC J-STD-020C	3	260	°C

**Table 5. Electrical Characteristics** ( $T_C = 25^\circ\text{C}$  unless otherwise noted)

Characteristic	Symbol	Min	Typ	Max	Unit
----------------	--------	-----	-----	-----	------

**Functional Tests** (In Freescale Test Fixture, 50 ohm system)  $V_{DS} = 26$  Vdc,  $I_{DQ1} = 90$  mA,  $I_{DQ2} = 240$  mA,  $P_{out} = 15$  W PEP,  $f_1 = 869$  MHz,  $f_2 = 869.1$  MHz and  $f_1 = 960$  MHz and  $f_2 = 960.1$  MHz, Two-Tone

Power Gain	$G_{ps}$	29	31	—	dB
Power Added Efficiency	PAE	29	31	—	%
Intermodulation Distortion	IMD	—	-40	-29	dBc
Input Return Loss	IRL	—	-15	-10	dB

1. Refer to AN1955/D, *Thermal Measurement Methodology of RF Power Amplifiers*. Go to <http://www.freescale.com/rf>.  
Select Documentation/Application Notes - AN1955.

(continued)

**Table 5. Electrical Characteristics** ( $T_C = 25^\circ\text{C}$  unless otherwise noted) (continued)

Characteristic	Symbol	Min	Typ	Max	Unit
<b>Typical Performances</b> (In Freescale Reference Board) $V_{DS} = 26\text{ V}$ , $I_{DQ1} = 60\text{ mA}$ , $I_{DQ2} = 240\text{ mA}$ , 869 MHz<Frequency>960 MHz					
Quiescent Current Accuracy over Temperature with 1.8 k $\Omega$ Gate Feed Resistors (-10 to 85°C) (1)	$\Delta I_{QT}$	—	$\pm 5$	—	%
Gain Flatness in 40 MHz Bandwidth @ $P_{out} = 3\text{ W CW}$	$G_F$	—	0.2	—	dB
Deviation from Linear Phase in 40 MHz Bandwidth @ $P_{out} = 3\text{ W CW}$	$\Phi$	—	$\pm 0.6$	—	°
Delay @ $P_{out} = 3\text{ W CW}$ Including Output Matching	Delay	—	2.5	—	ns
Part-to-Part Phase Variation @ $P_{out} = 3\text{ W CW}$	$\Delta\Phi$	—	$\pm 15$	—	°

**Typical GSM/GSM EDGE Performances** (In Freescale Reference Board)  $V_{DS} = 26\text{ V}$ ,  $I_{DQ1} = 60\text{ mA}$ ,  $I_{DQ2} = 240\text{ mA}$ , 869 MHz<Frequency>960 MHz

Output Power, 1dB Compression Point	P1dB	—	20	—	Watts
Power Gain @ $P_{out} = 15\text{ W CW}$	$G_{ps}$	—	30	—	dB
Power Added Efficiency @ $P_{out} = 15\text{ W CW}$	PAE	—	44	—	%
Input Return Loss @ $P_{out} = 15\text{ W CW}$	IRL	—	-15	—	dB
Error Vector Magnitude @ $P_{out} = 3\text{ W Avg.}$ including 0.6% rms source EVM	EVM	—	1.5	—	% rms
Spectral Regrowth at 400 kHz Offset @ $P_{out} = 3\text{ W Avg.}$	SR1	—	-65	—	dBc
Spectral Regrowth at 600 kHz Offset @ $P_{out} = 3\text{ W Avg.}$	SR2	—	-83	—	dBc

1. Refer to AN1977/D, *Quiescent Current Thermal Tracking Circuit in the RF Integrated Circuit Family*. Go to <http://www.freescale.com/rf>. Select Documentation/Application Notes - AN1977.

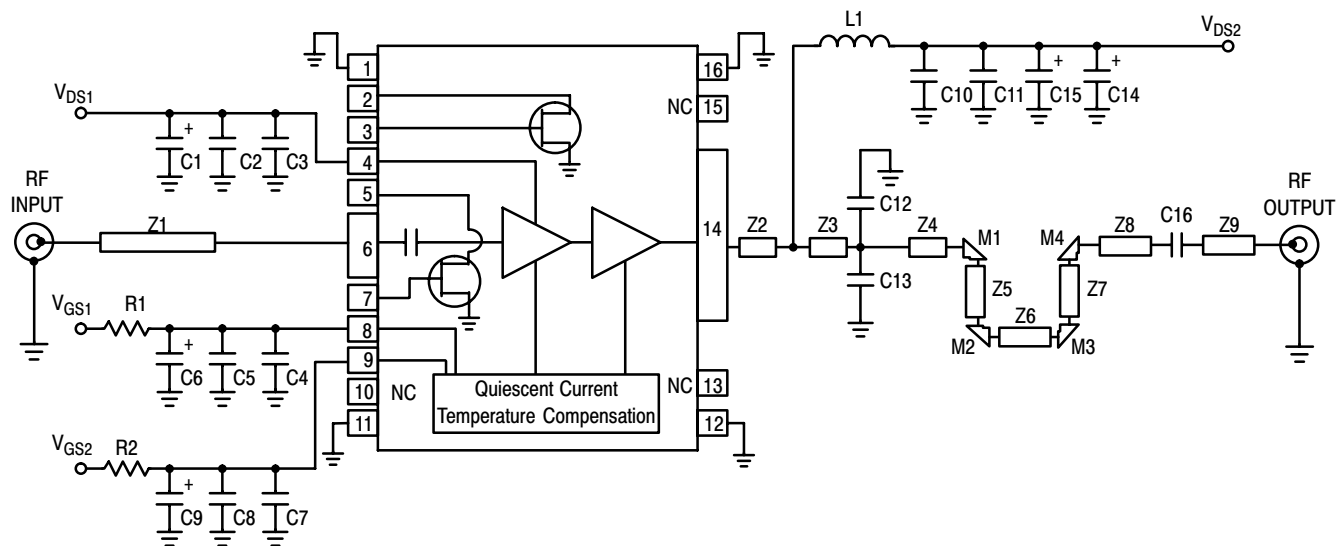

Z1	0.086" , 50 $\Omega$ Microstrip	Z6	0.157" x 0.283" Microstrip
Z2	0.133" x 0.236" Microstrip	Z7	0.429" x 0.283" Microstrip
Z3	0.435" x 0.283" Microstrip	Z8	0.394" x 0.088" Microstrip
Z4	0.171" x 0.283" Microstrip	Z9	0.181" x 0.088" Microstrip
Z5	0.429" x 0.283" Microstrip	PCB	Taconic TLX8, 0.030" , $\epsilon_r = 2.55$

**Figure 3. MW4IC915MBR1(GMBR1) Test Fixture Schematic**

**Table 6. MW4IC915MBR1(GMBR1) Test Fixture Component Designations and Values**

Part	Description	Part Number	Manufacturer
C1, C6, C9, C14	22 $\mu$ F, 35 V Tantalum Chip Capacitors	TAJE226M035R	AVX
C2, C5, C8, C11	1000 pF Chip Capacitors	100B102JCA500X	ATC
C3, C4, C7, C10, C16	22 pF Chip Capacitors	100B220JCA500X	ATC
C12, C13	10 pF Chip Capacitors	100B100JCA500X	ATC
C15	10 $\mu$ F Tantalum Chip Capacitor	T491X226K035AS4394	Kemet
L1	12.5 nH Inductor		
M1, M2, M3, M4	0.283" , 90° Mitered Microstrip Bends		
R1, R2	10 k $\Omega$ , 1/4 W Chip Resistor (1206)		

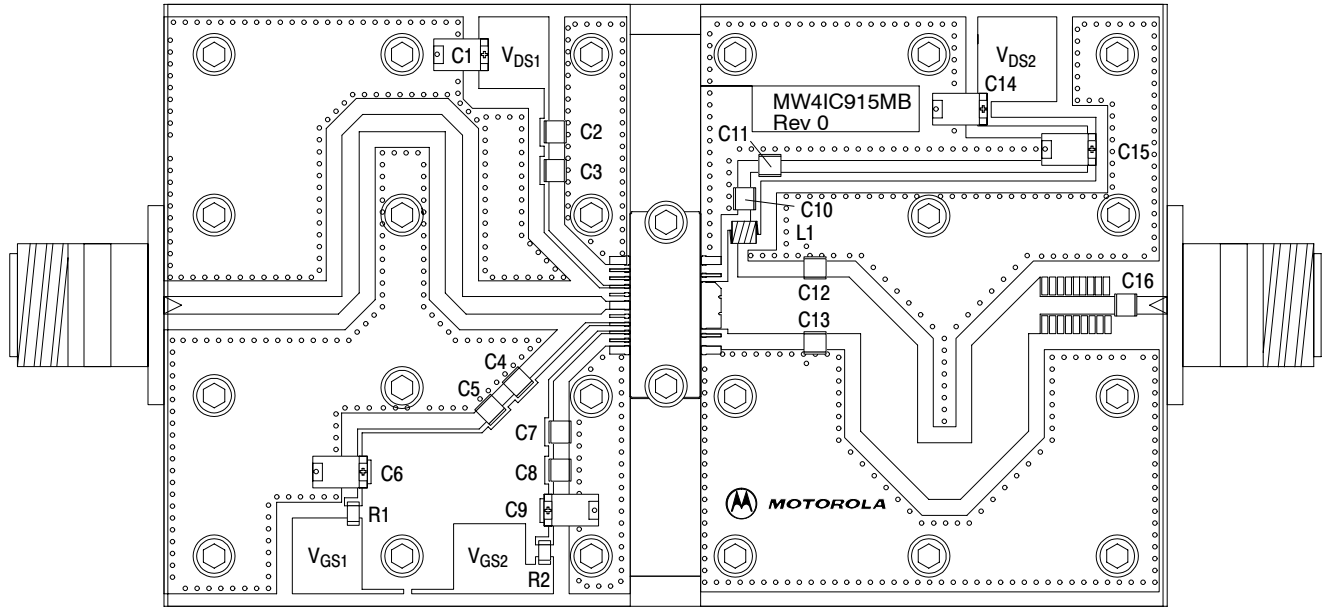

Freescale has begun the transition of marking Printed Circuit Boards (PCBs) with the Freescale Semiconductor signature/logo. PCBs may have either Motorola or Freescale markings during the transition period. These changes will have no impact on form, fit or function of the current product.

**Figure 4. MW4IC915MBR1(GMBR1) Test Fixture Component Layout**

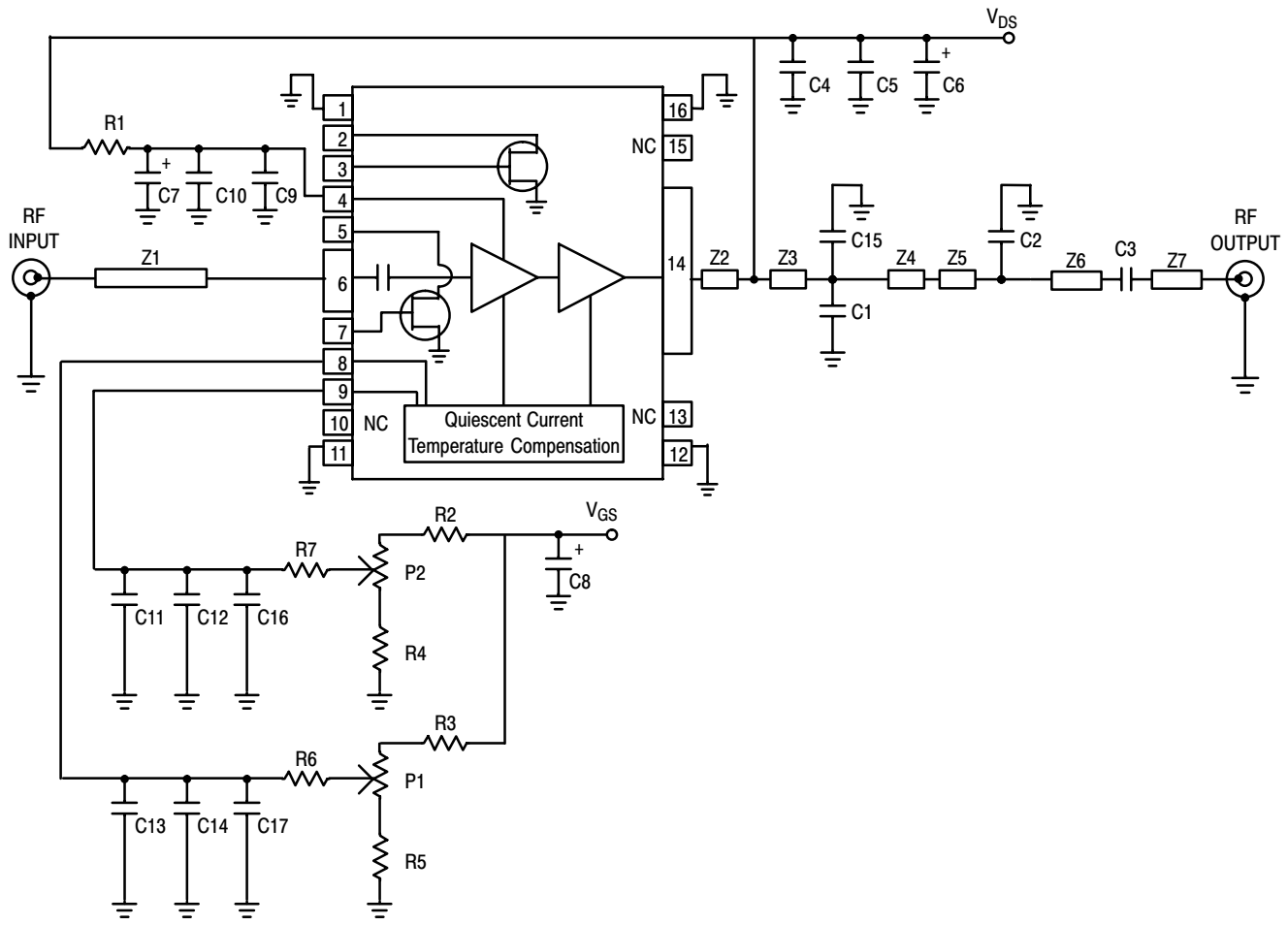

Z1	0.681" x 0.039", 50 $\Omega$ Microstrip	Z5	0.566" x 0.043" Microstrip
Z2	0.157" x 0.228" Microstrip	Z6	0.165" x 0.043" Microstrip
Z3	0.468" x 0.157" Microstrip	Z7	0.078" x 0.043" Microstrip
Z4	0.220" x 0.157" Microstrip	PCB	Taconic RF35, 0.02", $\epsilon_r = 3.5$

**Figure 5. MW4IC915MBR1(GMBR1) Reference Board Schematic**

**Table 7. MW4IC915MBR1(GMBR1) Reference Board Component Designations and Values**

Part	Description	Part Number	Manufacturer
C1, C15	10 pF Chip Capacitors (0805), ACCU-P	08051J100GBT	AVX
C2	5.6 pF Chip Capacitor (0805), ACCU-P	08051J5R6BBT	AVX
C3, C4, C9, C11, C13	33 pF Chip Capacitors (0805), ACCU-P	08051J330GB	AVX
C5, C10, C12, C14	10 nF Chip Capacitors (0805)	08055C103KAT	AVX
C6, C7, C8	22 $\mu$ F, 35 V Tantalum Capacitors	TAJE226MO35R	AVX
C16, C17	100 nF Chip Capacitors (0805)	08055C104KAT	AVX
P1, P2	5 k $\Omega$ Potentiometer CMS Cermet Multi-turn	3224W	Bourns
R1, R2, R3, R4, R5	0 $\Omega$ , 1/8 W Chip Resistors (0805)		
R6, R7	10 k $\Omega$ , 1/4 W Chip Resistors (1206)		

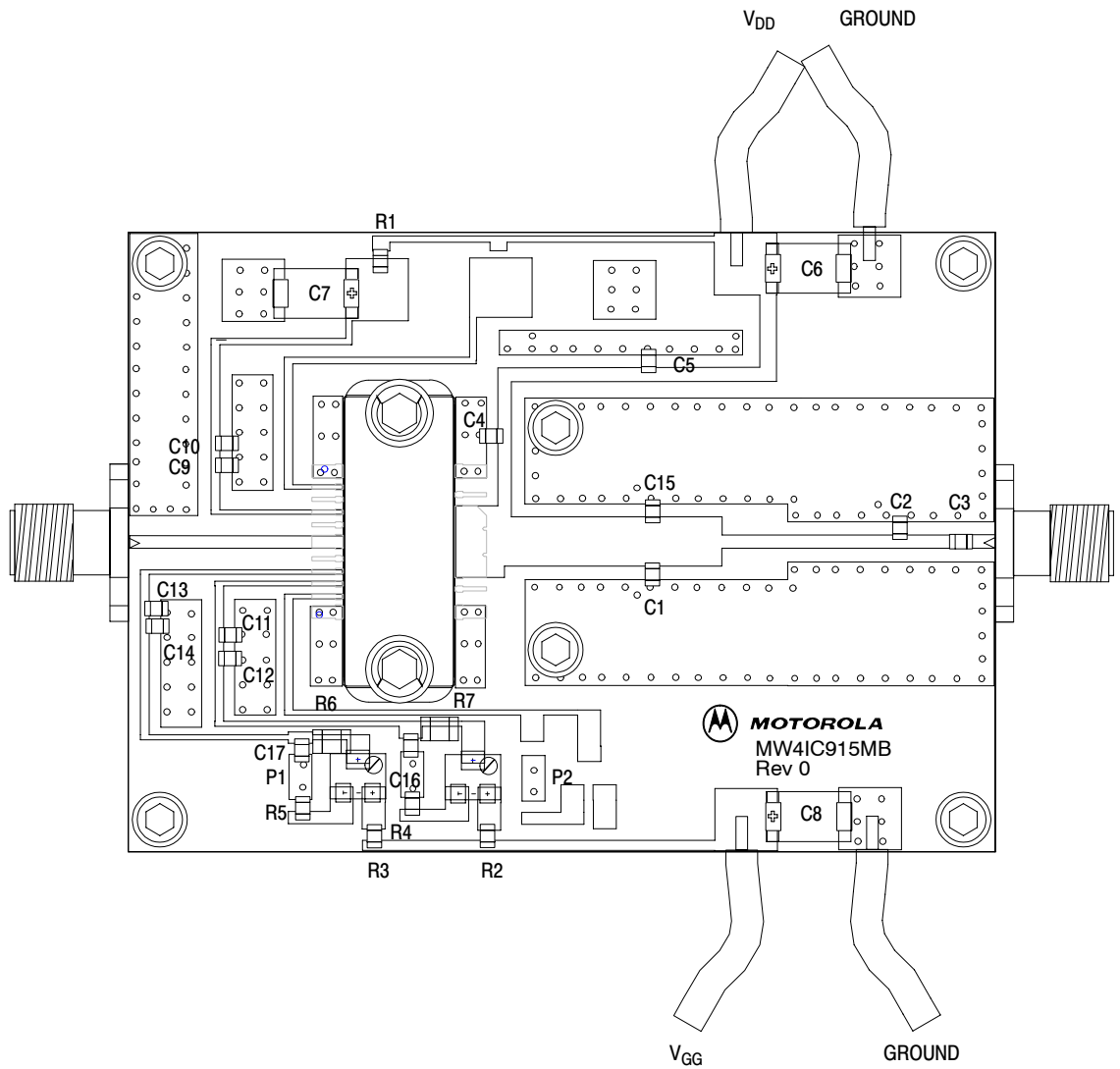

Freescale has begun the transition of marking Printed Circuit Boards (PCBs) with the Freescale Semiconductor signature/logo. PCBs may have either Motorola or Freescale markings during the transition period. These changes will have no impact on form, fit or function of the current product.

**Figure 6. MW4IC915MBR1(GMBR1) Reference Board Component Layout**

TYPICAL CHARACTERISTICS (FREESCALE TEST FIXTURE, 50 OHM SYSTEM)

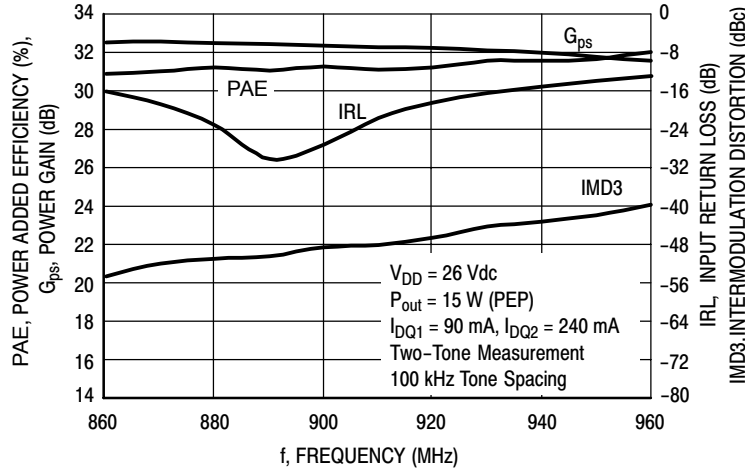

Figure 7. Two-Tone Wideband Circuit Performance @  $P_{out} = 15$  Watts PEP

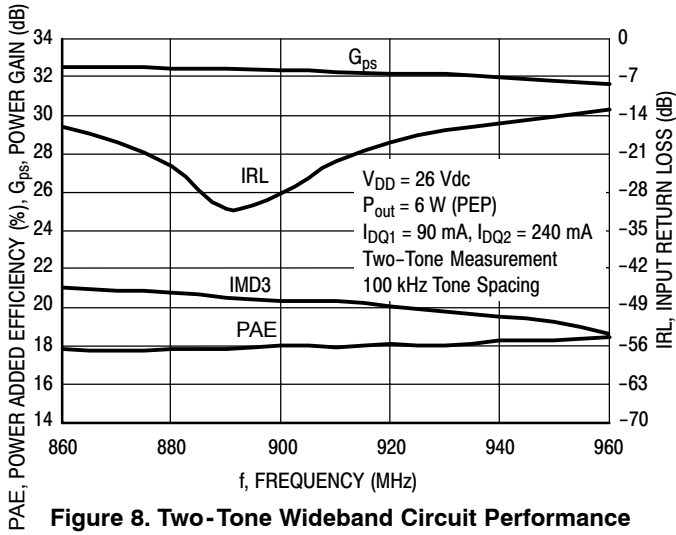

Figure 8. Two-Tone Wideband Circuit Performance @  $P_{out} = 6$  Watts

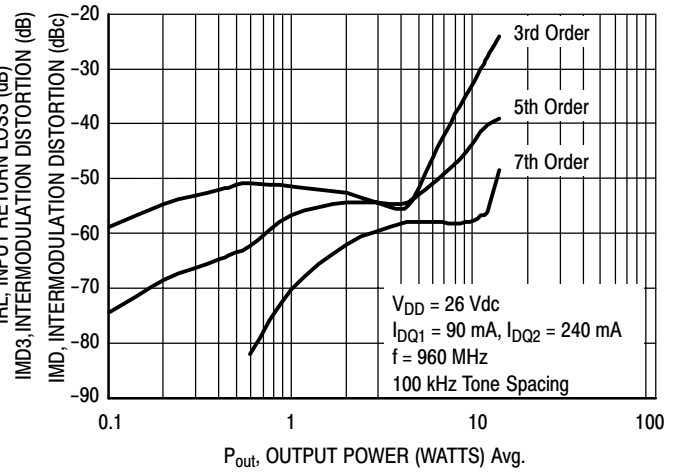

Figure 9. Intermodulation Distortion Products versus Output Power

TYPICAL CHARACTERISTICS (FREESCALE REFERENCE BOARD)

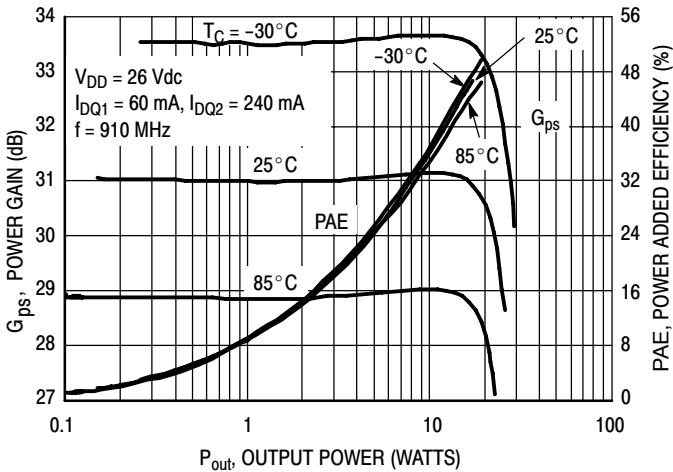

Figure 10. Power Gain and Power Added Efficiency versus Output Power

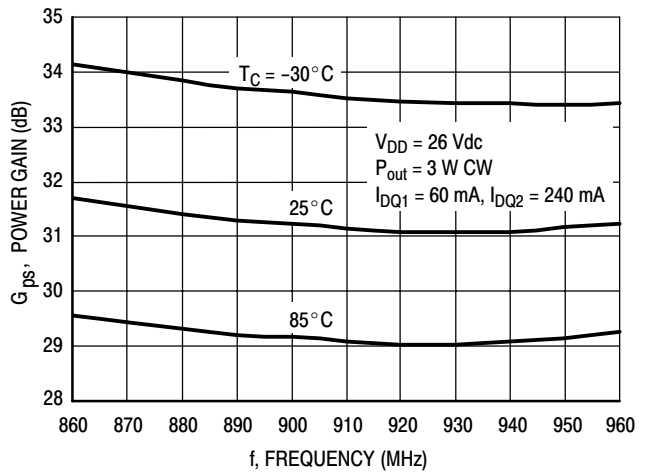

Figure 11. Power Gain versus Frequency

TYPICAL CHARACTERISTICS (FREESCALE REFERENCE BOARD) - CONTINUED

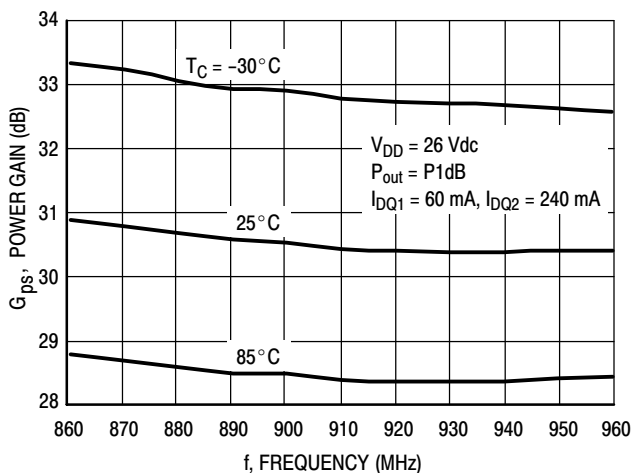

Figure 12. Power Gain versus Frequency

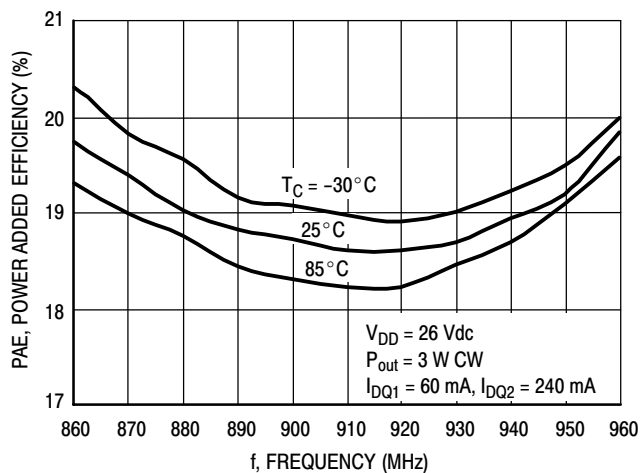

Figure 13. Power Added Efficiency versus Frequency

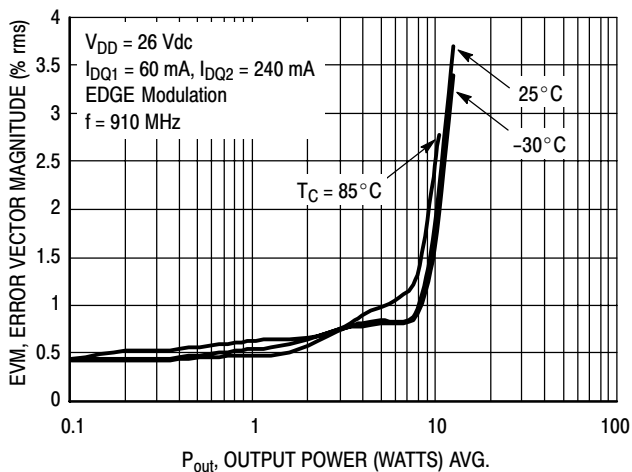

Figure 14. Error Vector Magnitude versus Output Power

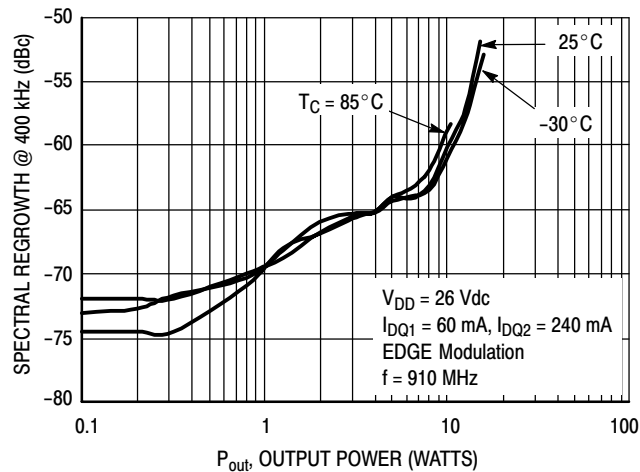

Figure 15. Spectral Regrowth at 400 kHz versus Output Power

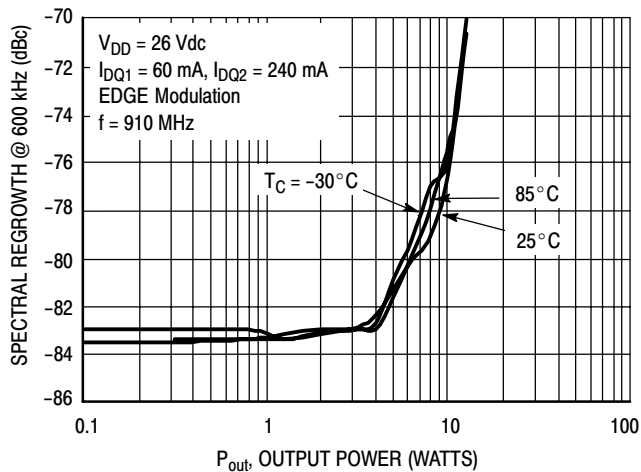
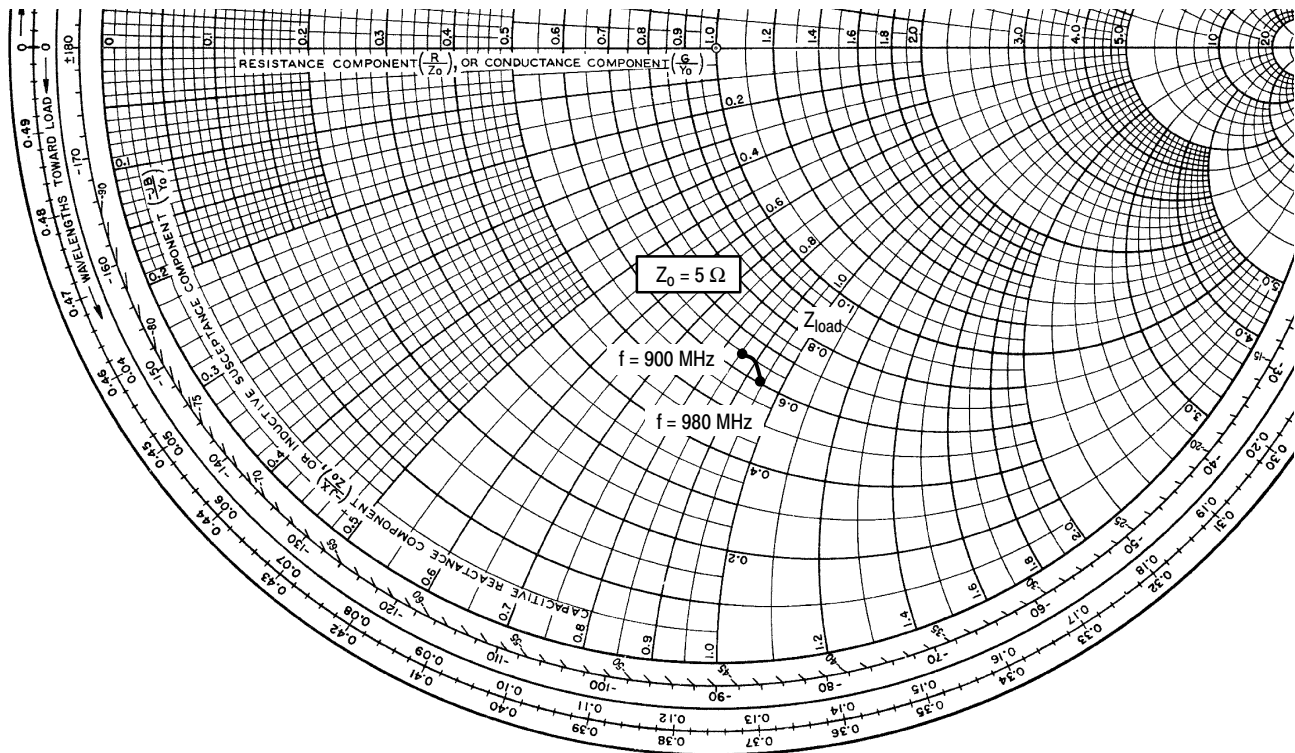

Figure 16. Spectral Regrowth at 600 kHz versus Output Power



$V_{DD} = 26\text{ V}$ ,  $I_{DQ1} = 60\text{ mA}$ ,  $I_{DQ2} = 240\text{ mA}$ ,  $P_{out} = P_{1dB}$

f MHz	$Z_{load}$ $\Omega$
900	3.23 - j4.30
910	3.24 - j4.36
920	3.25 - j4.42
930	3.25 - j4.47
940	3.23 - j4.52
950	3.21 - j4.56
960	3.16 - j4.60
970	3.11 - j4.65
980	3.04 - j4.70

$Z_{load}$  = Test circuit impedance as measured from drain to ground.

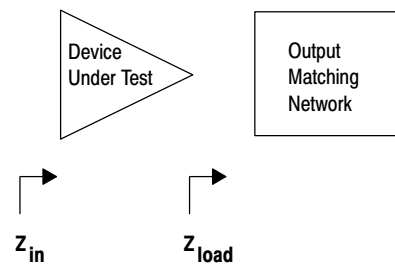

Figure 17. Series Equivalent Input and Load Impedance



# NOTES

# NOTES



# NOTES



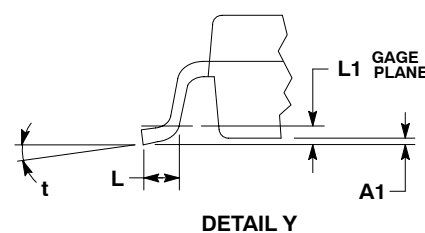
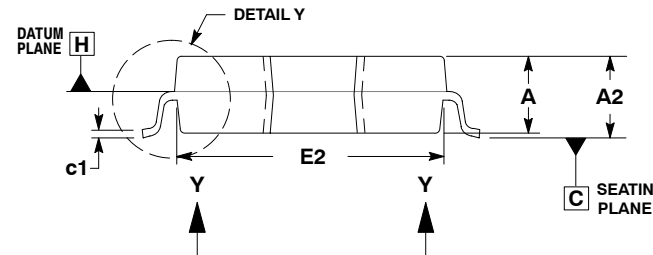
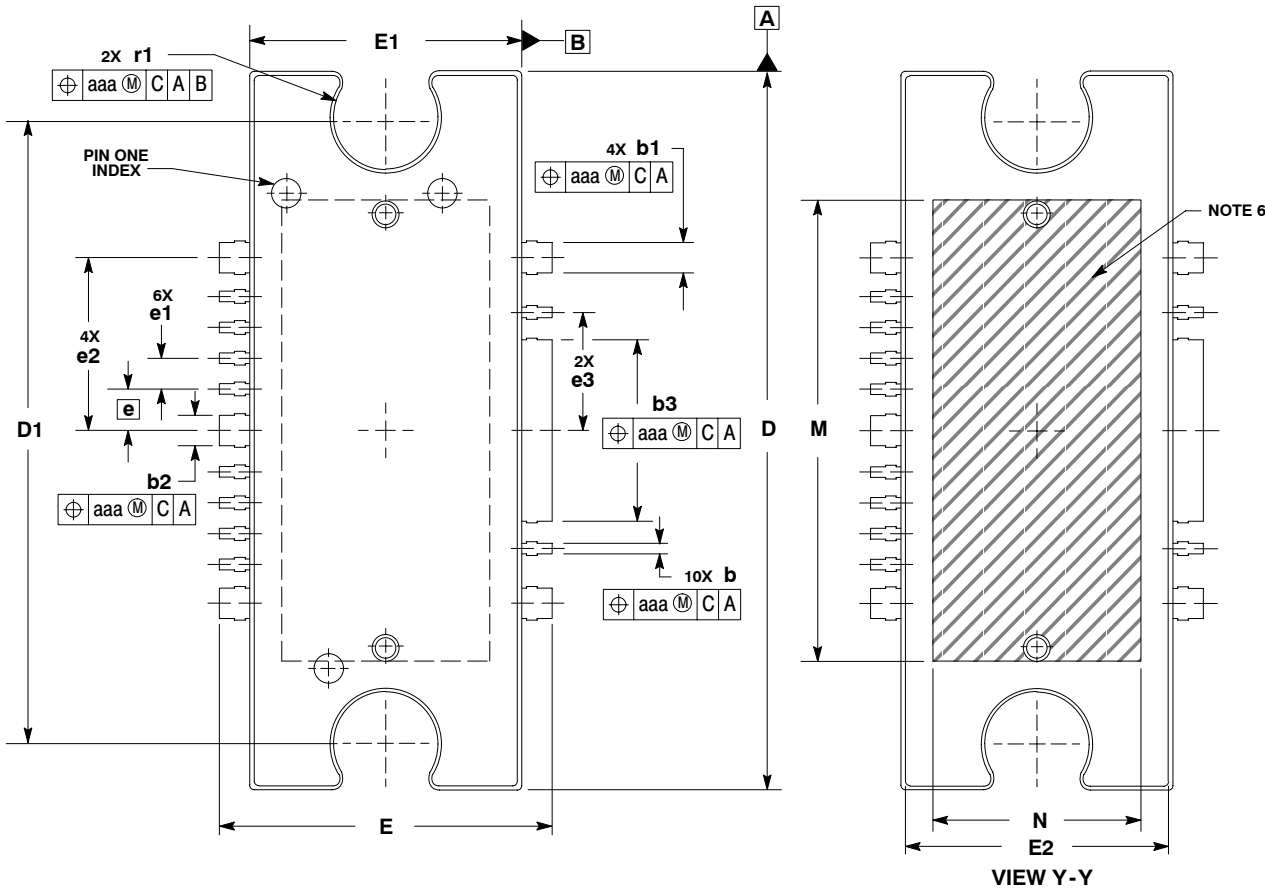

- NOTES:
1. CONTROLLING DIMENSION: INCH.
  2. INTERPRET DIMENSIONS AND TOLERANCES PER ASME Y14.5M-1994.
  3. DATUM PLANE -H- IS LOCATED AT TOP OF LEAD AND IS COINCIDENT WITH THE LEAD WHERE THE LEAD EXITS THE PLASTIC BODY AT THE TOP OF THE PARTING LINE.
  4. DIMENSIONS "D" AND "E1" DO NOT INCLUDE MOLD PROTRUSION. ALLOWABLE PROTRUSION IS .006 (0.15) PER SIDE. DIMENSIONS "D" AND "E1" DO INCLUDE MOLD MISMATCH AND ARE DETERMINED AT DATUM PLANE -H-.
  5. DIMENSIONS "b", "b1", "b2" AND "b3" DO NOT INCLUDE DAMBAR PROTRUSION. ALLOWABLE DAMBAR PROTRUSION SHALL BE .005 (0.13) TOTAL IN EXCESS OF THE "b", "b1", "b2" AND "b3" DIMENSIONS AT MAXIMUM MATERIAL CONDITION.
  6. HATCHING REPRESENTS THE EXPOSED AREA OF THE HEAT SINK.

DIM	INCHES		MILLIMETERS	
	MIN	MAX	MIN	MAX
A	.100	.104	2.54	2.64
A1	.001	.004	0.02	0.10
A2	.099	.110	2.51	2.79
D	.928	.932	23.57	23.67
D1	.810 BSC		20.57 BSC	
E	.429	.437	10.90	11.10
E1	.353	.357	8.97	9.07
E2	.346	.350	8.79	8.89
L	.018	.024	4.90	5.06
L1	.01 BSC		0.25 BSC	
M	.600	---	15.24	---
N	.270	---	6.86	---
b	.011	.017	0.28	0.43
b1	.037	.043	0.94	1.09
b2	.037	.043	0.94	1.09
b3	.225	.231	5.72	5.87
c1	.007	.011	.18	.28
e	.054 BSC		1.37 BSC	
e1	.040 BSC		1.02 BSC	
e2	.224 BSC		5.69 BSC	
e3	.150 BSC		3.81 BSC	
r1	.063	.068	1.6	1.73
t	2°	8°	2°	8°
aaa	.004		.10	

**CASE 1329A-03  
ISSUE B  
TO-272 WB-16 GULL  
PLASTIC  
MW4IC915GMBR1**

MW4IC915GMBR1 MW4IC915GMBR1

## **How to Reach Us:**

**Home Page:**  
[www.freescale.com](http://www.freescale.com)

**E-mail:**  
[support@freescale.com](mailto:support@freescale.com)

**USA/Europe or Locations Not Listed:**  
Freescale Semiconductor  
Technical Information Center, CH370  
1300 N. Alma School Road  
Chandler, Arizona 85224  
+1-800-521-6274 or +1-480-768-2130  
[support@freescale.com](mailto:support@freescale.com)

**Europe, Middle East, and Africa:**  
Freescale Halbleiter Deutschland GmbH  
Technical Information Center  
Schatzbogen 7  
81829 Muenchen, Germany  
+44 1296 380 456 (English)  
+46 8 52200080 (English)  
+49 89 92103 559 (German)  
+33 1 69 35 48 48 (French)  
[support@freescale.com](mailto:support@freescale.com)

**Japan:**  
Freescale Semiconductor Japan Ltd.  
Headquarters  
ARCO Tower 15F  
1-8-1, Shimo-Meguro, Meguro-ku,  
Tokyo 153-0064  
Japan  
0120 191014 or +81 3 5437 9125  
[support.japan@freescale.com](mailto:support.japan@freescale.com)

**Asia/Pacific:**  
Freescale Semiconductor Hong Kong Ltd.  
Technical Information Center  
2 Dai King Street  
Tai Po Industrial Estate  
Tai Po, N.T., Hong Kong  
+800 2666 8080  
[support.asia@freescale.com](mailto:support.asia@freescale.com)

**For Literature Requests Only:**  
Freescale Semiconductor Literature Distribution Center  
P.O. Box 5405  
Denver, Colorado 80217  
1-800-441-2447 or 303-675-2140  
Fax: 303-675-2150  
[LDCForFreescaleSemiconductor@hibbertgroup.com](mailto:LDCForFreescaleSemiconductor@hibbertgroup.com)

Information in this document is provided solely to enable system and software implementers to use Freescale Semiconductor products. There are no express or implied copyright licenses granted hereunder to design or fabricate any integrated circuits or integrated circuits based on the information in this document.

Freescale Semiconductor reserves the right to make changes without further notice to any products herein. Freescale Semiconductor makes no warranty, representation or guarantee regarding the suitability of its products for any particular purpose, nor does Freescale Semiconductor assume any liability arising out of the application or use of any product or circuit, and specifically disclaims any and all liability, including without limitation consequential or incidental damages. "Typical" parameters that may be provided in Freescale Semiconductor data sheets and/or specifications can and do vary in different applications and actual performance may vary over time. All operating parameters, including "Typicals", must be validated for each customer application by customer's technical experts. Freescale Semiconductor does not convey any license under its patent rights nor the rights of others. Freescale Semiconductor products are not designed, intended, or authorized for use as components in systems intended for surgical implant into the body, or other applications intended to support or sustain life, or for any other application in which the failure of the Freescale Semiconductor product could create a situation where personal injury or death may occur. Should Buyer purchase or use Freescale Semiconductor products for any such unintended or unauthorized application, Buyer shall indemnify and hold Freescale Semiconductor and its officers, employees, subsidiaries, affiliates, and distributors harmless against all claims, costs, damages, and expenses, and reasonable attorney fees arising out of, directly or indirectly, any claim of personal injury or death associated with such unintended or unauthorized use, even if such claim alleges that Freescale Semiconductor was negligent regarding the design or manufacture of the part.

Freescale™ and the Freescale logo are trademarks of Freescale Semiconductor, Inc. All other product or service names are the property of their respective owners.  
© Freescale Semiconductor, Inc. 2004. All rights reserved.

