



NEC's MEDIUM POWER NPN SILICON HIGH FREQUENCY TRANSISTOR

NE677M04

FEATURES

- **HIGH GAIN BANDWIDTH:**
f_T = 15 GHz
- **HIGH OUTPUT POWER:**
P_{-1dB} = 15 dBm at 1.8 GHz
- **HIGH LINEAR GAIN:**
G_L = 15.5 dB at 1.8 GHz
- **NEW LOW PROFILE M04 PACKAGE:**
SOT-343 footprint, with a height of only 0.59 mm
Flat lead style for better RF performance

DESCRIPTION

NEC's NE677M04 is fabricated using NEC's HFT3 wafer process. With a transition frequency of 15 GHz, the NE677M04 is usable in applications from 100 MHz to 3 GHz. The NE677M04 provides P_{1dB} of 15 dBm, even with low voltage and low current, making this device an excellent choice for the driver stage for mobile or fixed wireless applications.

NEC's NE677M04 is housed in NEC's new low profile/flat lead style "M04" package

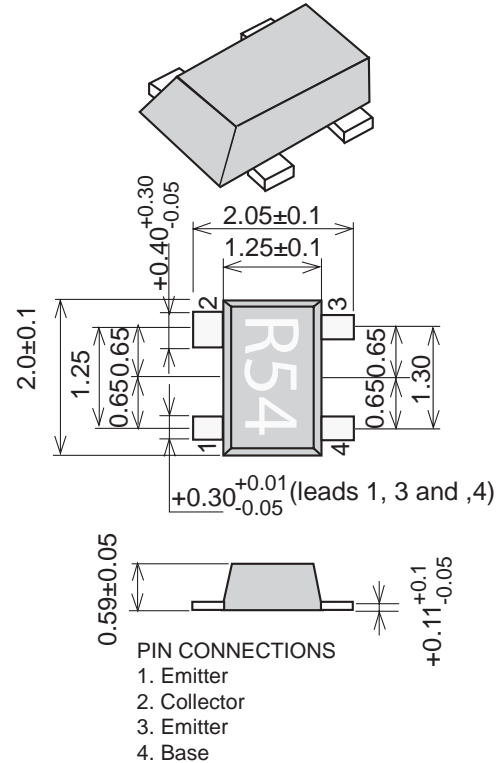

ELECTRICAL CHARACTERISTICS (T_A = 25°C)

PART NUMBER PACKAGE OUTLINE EIAJ ³ REGISTRATION NUMBER		NE677M04 M04 2SC5751				
SYMBOLS	PARAMETERS AND CONDITIONS	UNITS	MIN	TYP	MAX	
DC	I _{CBO}	Collector Cutoff Current at V _{CB} = 5V, I _E = 0	nA		100	
	I _{EBO}	Emitter Cutoff Current at V _{EB} = 1V, I _C = 0	nA		100	
	h _{FE}	DC Current ¹ Gain at V _{CE} = 3V, I _C = 20 mA		75	120	150
RF	P _{1dB}	Output Power at 1 dB compression point at V _{CE} = 2.8V, I _{CQ} = 8 mA, f = 1.8 GHz, P _{in} = 1 dBm	dBm		15.0	
	G _L	Linear Gain at V _{CE} = 2.8V, I _{CQ} = 8 mA, f = 1.8 GHz, P _{in} = -10 dBm	dB		15.5	
	MAG	Maximum Available Gain ⁴ at V _{CE} = 3V, I _C = 20 mA, f = 2 GHz	dBm		16.0	
	S _{21E} ²	Insertion Power Gain at V _{CE} = 3V, I _C = 20 mA, f = 2 GHz	dB	10.0	13.5	
	η _c	Collector Efficiency at V _{CE} = 2.8V, I _{CQ} = 8 mA, f = 1.8 GHz, P _{in} = 1 dBm	%		50	
	NF	Noise Figure at V _{CE} = 3V, I _C = 5 mA, f = 2 GHz, Z _s = Z _{OPT}	dB		1.7	2.5
	f _T	Gain Bandwidth at V _{CE} = 3V, I _C = 20 mA, f = 2 GHz	GHz		15	
Cre	Reverse Transfer Capacitance ² at V _{CB} = 3V, I _C = 0, f = 1 MHz	pF		0.22	0.50	

Notes:

1. Pulsed measurement, pulse width ≤ 350 μs, duty cycle ≤ 2 %.
2. Collector to Base capacitance measured by capacitance meter (automatic balance bridge method) when emitter pin is connected to the guard pin of capacitance meter.
3. Electronic Industrial Association of Japan
4. $MAG = \frac{|S_{21}|}{|S_{12}|} (K \pm \sqrt{K^2 - 1})$.

ABSOLUTE MAXIMUM RATINGS¹ (T_A = 25°C)

SYMBOLS	PARAMETERS	UNITS	RATINGS
V _{CB0}	Collector to Base Voltage	V	9.0
V _{CE0}	Collector to Emitter Voltage	V	6.0
V _{EB0}	Emitter to Base Voltage	V	2.0
I _C	Collector Current	mA	50
P _T	Total Power Dissipation ²	mW	205
T _J	Junction Temperature	°C	150
T _{STG}	Storage Temperature	°C	-65 to +150

Note:

1. Operation in excess of any one of these parameters may result in permanent damage.
2. Mounted on a 1.08cm² x 1.0 mm thick glass epoxy PCB.

ORDERING INFORMATION

PART NUMBER	QUANTITY
NE677M04-T2	3k pcs./reel

THERMAL RESISTANCE

SYMBOLS	PARAMETERS	UNITS	RATINGS
R _{th j-a}	Thermal Resistance from Junction to Ambient	°C/W	600

Note:

1. Mounted on a 1.08cm² x 1.0 mm thick glass epoxy PCB.

TYPICAL PERFORMANCE CURVES (T_A = 25 °C)

TOTAL POWER DISSIPATION vs. AMBIENT TEMPERATURE

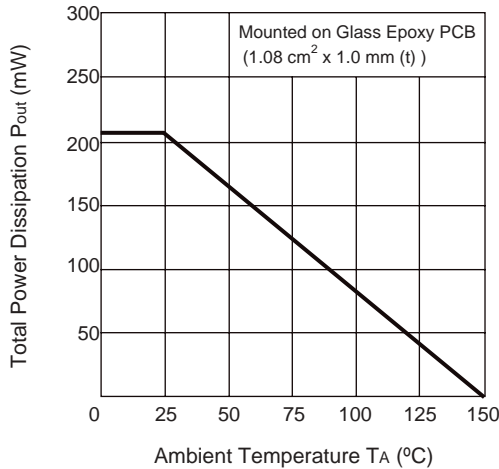

REVERSE TRANSFER CAPACITANCE vs. COLLECTOR TO BASE VOLTAGE

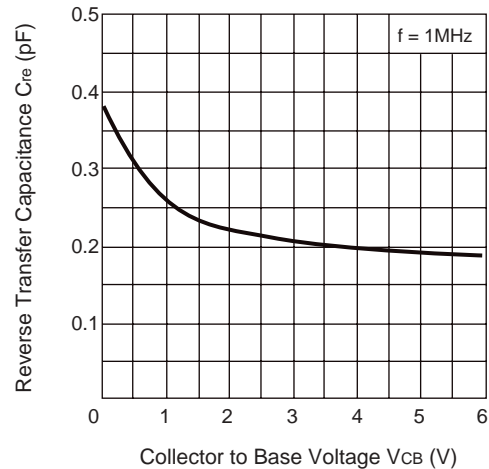

COLLECTOR CURRENT vs. COLLECTOR TO EMITTER VOLTAGE

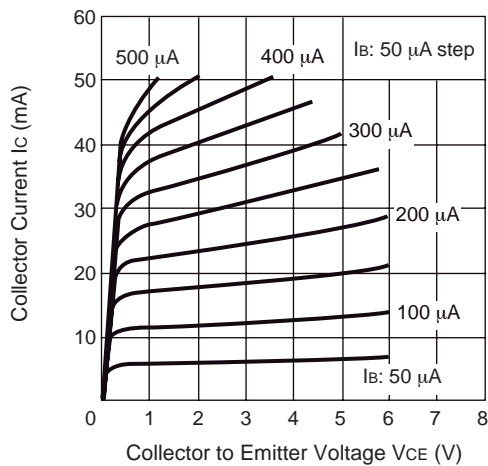

DC CURRENT GAIN vs. COLLECTOR CURRENT

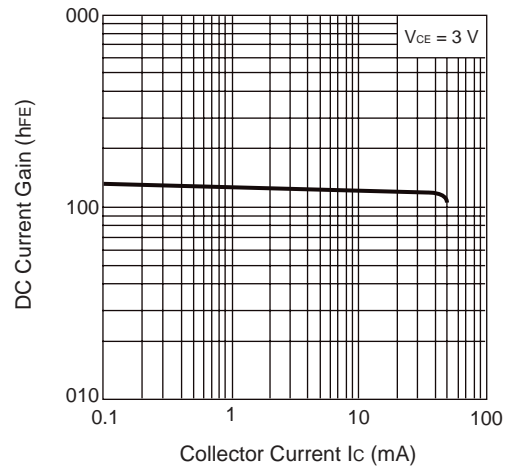

TYPICAL PERFORMANCE CURVES (TA = 25 °C)

GAIN BANDWIDTH PRODUCT vs. COLLECTOR CURRENT

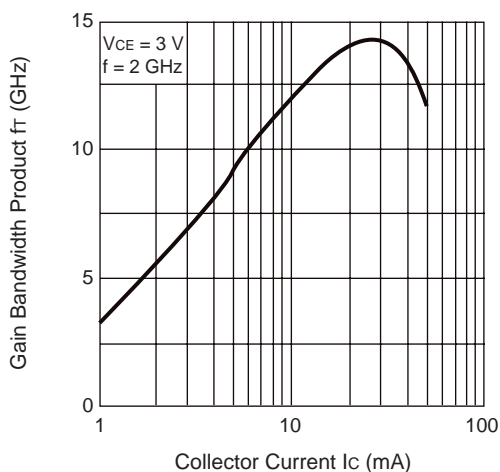

INSERTION POWER GAIN, MAG, MSG vs. FREQUENCY

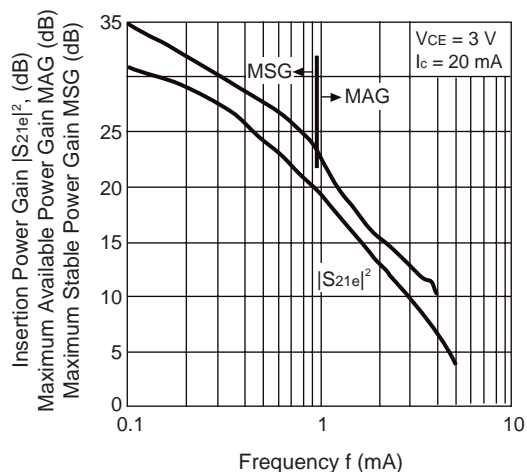

INSERTION POWER GAIN, MAG, MSG vs. COLLECTOR CURRENT

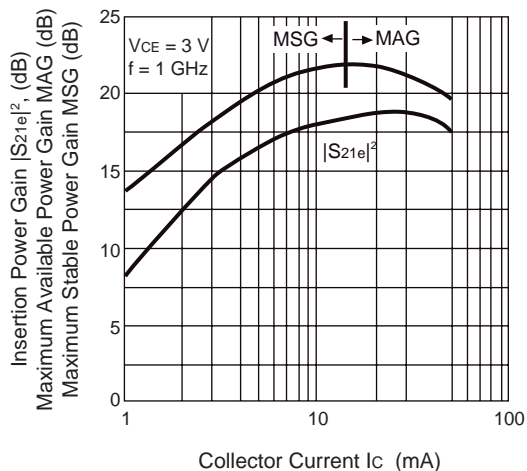

INSERTION POWER GAIN, MAG, MSG vs. COLLECTOR CURRENT

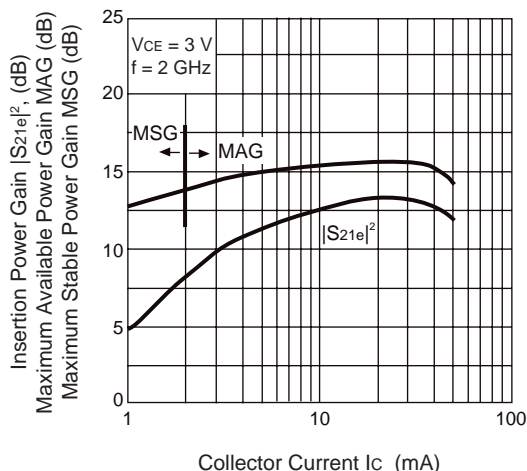

INSERTION POWER GAIN, MAG vs. COLLECTOR CURRENT

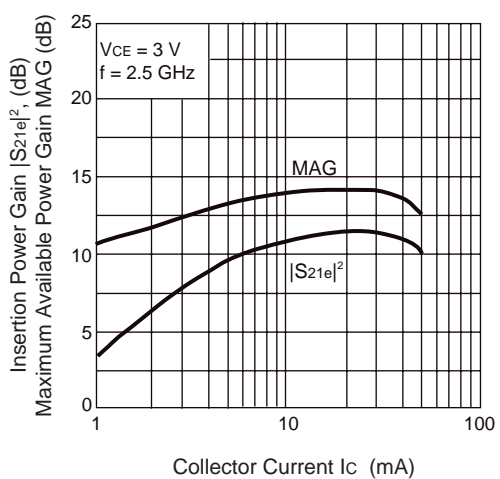

NOISE FIGURE, ASSOCIATED GAIN vs. COLLECTOR CURRENT

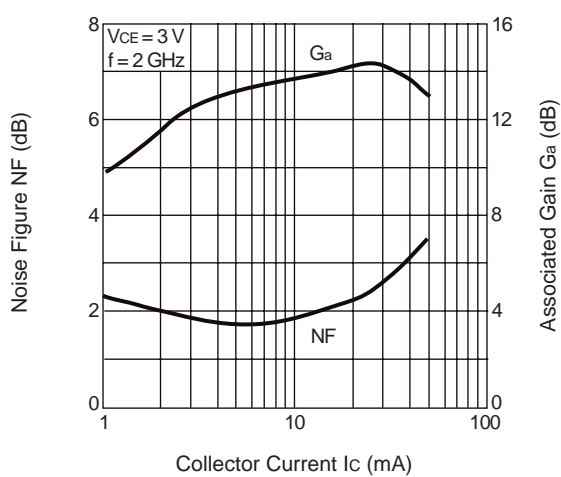

TYPICAL PERFORMANCE CURVES (TA = 25 °C)

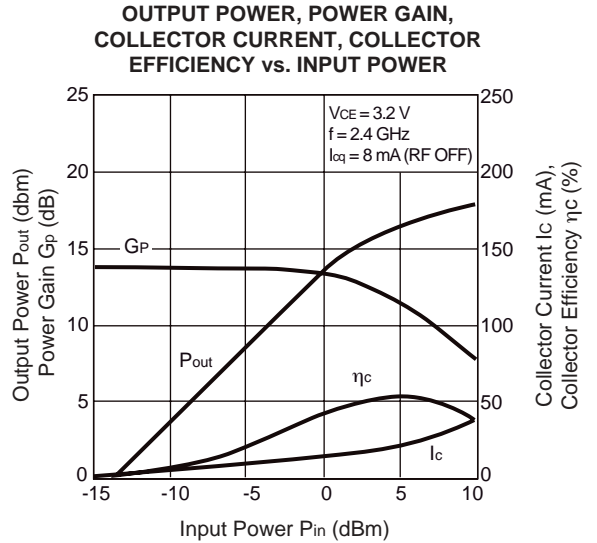
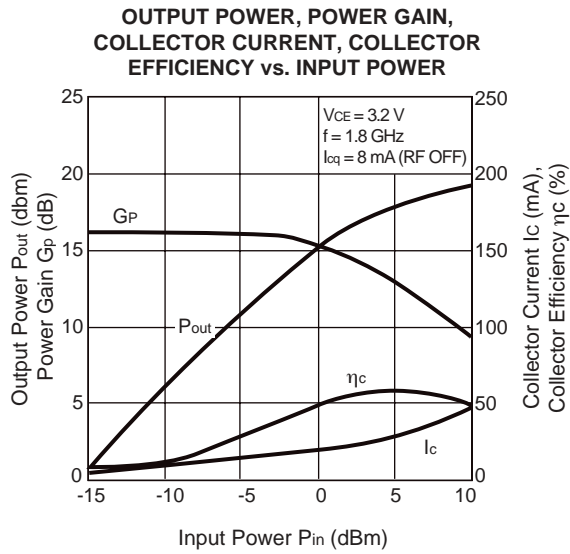
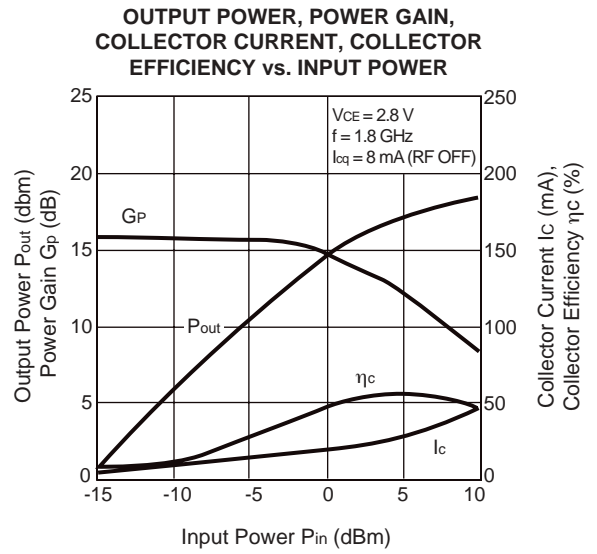
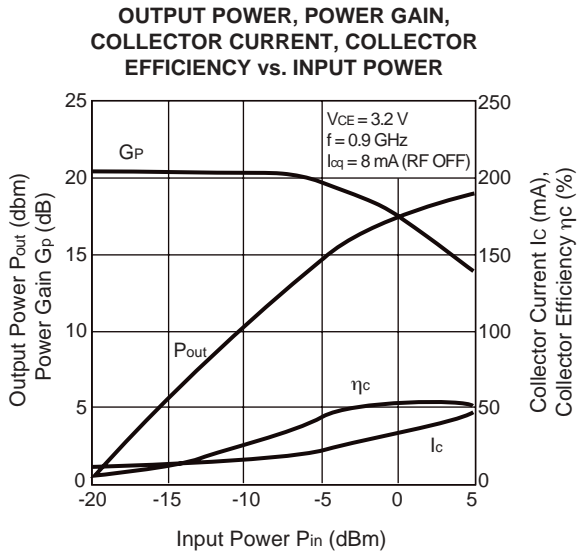

TYPICAL SCATTERING PARAMETERS (TA = 25°C)

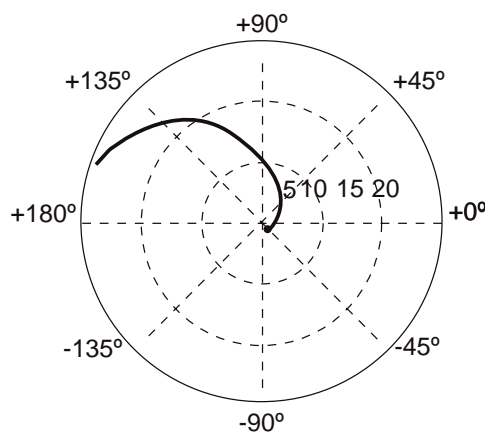
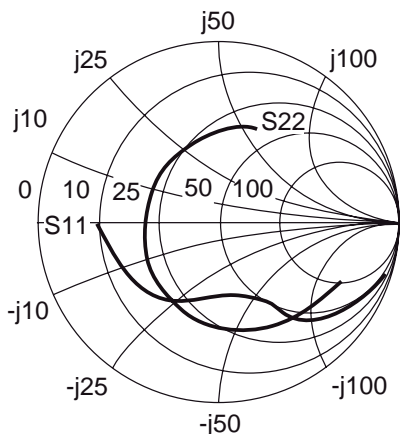

NE677M04
Vc = 2 V, Ic = 10 mA

FREQUENCY GHz	S11		S21		S12		S22		K	MAG ¹ (dB)
	MAG	ANG	MAG	ANG	MAG	ANG	MAG	ANG		
0.100	0.72	-28.02	23.85	159.39	0.01	76.80	0.94	-17.17	0.11	32.34
0.200	0.67	-53.32	21.19	142.90	0.02	61.76	0.85	-30.90	0.22	29.46
0.300	0.62	-74.47	18.36	129.52	0.03	53.97	0.75	-41.48	0.30	27.71
0.400	0.57	-91.69	15.78	119.03	0.04	47.84	0.66	-49.21	0.38	26.40
0.500	0.54	-105.42	13.68	110.66	0.04	44.49	0.60	-55.01	0.46	25.44
0.600	0.50	-119.13	11.77	103.58	0.04	41.61	0.51	-57.12	0.62	24.54
0.700	0.48	-128.64	10.42	97.78	0.04	40.18	0.48	-61.53	0.69	23.81
0.800	0.47	-136.17	9.33	92.96	0.05	39.74	0.45	-63.91	0.75	23.13
0.900	0.46	-143.27	8.43	88.43	0.05	39.29	0.43	-66.99	0.82	22.51
1.000	0.46	-148.66	7.70	84.44	0.05	39.40	0.42	-69.40	0.87	21.95
1.500	0.44	-170.56	5.30	67.31	0.06	40.48	0.39	-82.07	1.10	17.66
1.800	0.43	179.75	4.47	58.55	0.06	41.76	0.39	-89.26	1.19	15.82
1.900	0.43	176.51	4.24	55.72	0.07	41.66	0.39	-91.76	1.20	15.33
2.000	0.43	173.63	4.04	52.97	0.07	42.00	0.40	-94.18	1.22	14.87
2.500	0.42	159.00	3.26	39.73	0.08	42.28	0.42	-105.45	1.26	13.00
3.000	0.42	144.48	2.73	27.19	0.10	40.73	0.46	-115.95	1.24	11.64
3.500	0.43	129.44	2.34	15.06	0.11	38.24	0.49	-125.23	1.18	10.67
4.000	0.45	115.14	2.04	3.42	0.13	34.92	0.53	-134.51	1.11	9.99
4.500	0.48	102.37	1.79	-7.89	0.14	30.39	0.56	-144.23	1.04	9.71
5.000	0.50	91.32	1.59	-18.83	0.16	25.33	0.59	-154.88	0.97	9.94
5.500	0.53	81.53	1.42	-29.44	0.18	19.49	0.62	-165.89	0.90	9.00
6.000	0.55	72.28	1.27	-39.61	0.20	13.49	0.66	-176.84	0.85	8.11

Note:

1. Gain Calculations:

$$MAG = \frac{|S_{21}|}{|S_{12}|} (K - \sqrt{K^2 - 1})$$

When $K \geq 1$, MAG is undefined and MSG values are used. $MSG = \frac{|S_{21}|}{|S_{12}|}$, $K = \frac{1 + |\Delta|^2 - |S_{11}|^2 - |S_{22}|^2}{2 |S_{12} S_{21}|}$, $\Delta = S_{11} S_{22} - S_{21} S_{12}$

MAG = Maximum Available Gain

MSG = Maximum Stable Gain

TYPICAL SCATTERING PARAMETERS (TA = 25°C)

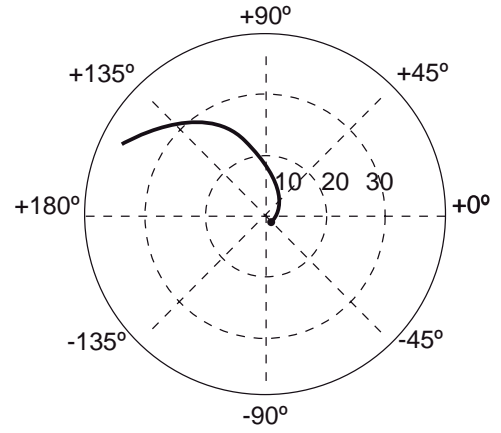
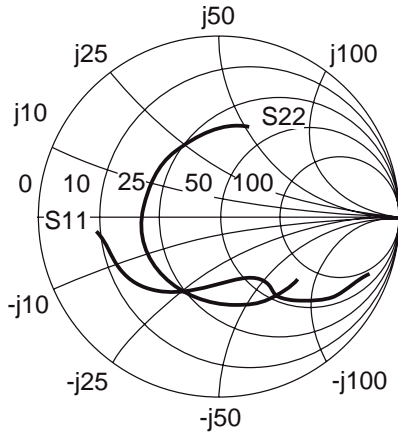

NE677M04

Vc = 3 V, Ic = 20 mA

FREQUENCY GHz	S11		S21		S12		S22		K	MAG ¹ (dB)
	MAG	ANG	MAG	ANG	MAG	ANG	MAG	ANG		
0.100	0.58	-36.91	34.82	154.30	0.01	65.53	0.91	-19.74	0.28	35.64
0.200	0.53	-67.97	29.03	135.74	0.02	59.98	0.78	-33.77	0.34	32.23
0.300	0.49	-91.49	23.80	122.19	0.02	55.05	0.67	-43.13	0.45	30.35
0.400	0.46	-108.88	19.70	112.29	0.03	51.06	0.58	-49.18	0.56	28.90
0.500	0.44	-121.87	16.66	104.71	0.03	49.50	0.52	-53.43	0.65	27.72
0.600	0.42	-135.00	14.16	98.54	0.03	48.74	0.45	-53.84	0.81	26.72
0.700	0.42	-143.29	12.41	93.35	0.03	49.30	0.42	-57.21	0.89	25.86
0.800	0.41	-149.68	11.03	89.03	0.03	50.12	0.40	-58.72	0.95	25.08
0.900	0.41	-155.84	9.91	84.93	0.04	50.69	0.39	-61.16	0.99	24.32
1.000	0.41	-160.23	9.01	81.35	0.04	51.41	0.38	-63.04	1.04	22.48
1.500	0.40	-178.96	6.14	65.55	0.05	53.28	0.37	-74.89	1.17	18.28
1.800	0.39	-172.52	5.16	57.30	0.06	53.31	0.38	-82.12	1.20	16.70
1.900	0.39	-169.64	4.90	54.62	0.06	53.31	0.38	-84.61	1.20	16.25
2.000	0.39	-167.05	4.66	52.02	0.06	53.16	0.38	-87.15	1.21	15.82
2.500	0.39	-153.59	3.75	39.33	0.08	51.37	0.42	-98.84	1.19	14.09
3.000	0.39	-139.95	3.14	27.21	0.10	48.43	0.45	-109.77	1.15	12.83
3.500	0.41	-125.64	2.68	15.39	0.11	44.68	0.49	-119.46	1.09	12.00
4.000	0.43	-111.98	2.34	3.97	0.13	40.02	0.53	-129.07	1.02	11.72
4.500	0.45	-99.88	2.06	-7.19	0.15	34.90	0.56	-139.11	0.95	11.48
5.000	0.48	-89.38	1.83	-18.07	0.16	29.26	0.60	-150.00	0.88	10.49
5.500	0.51	-80.01	1.64	-28.76	0.18	22.90	0.63	-161.27	0.82	9.55
6.000	0.53	-71.10	1.47	-39.12	0.20	16.56	0.66	-172.54	0.77	8.69

Note:

1. Gain Calculations:

$$MAG = \frac{|S_{21}|}{|S_{12}|} (K - \sqrt{K^2 - 1})$$

. When $K \geq 1$, MAG is undefined and MSG values are used. $MSG = \frac{|S_{21}|}{|S_{12}|}$, $K = \frac{1 + |\Delta|^2 - |S_{11}|^2 - |S_{22}|^2}{2 |S_{12} S_{21}|}$, $\Delta = S_{11} S_{22} - S_{21} S_{12}$

MAG = Maximum Available Gain

MSG = Maximum Stable Gain

TYPICAL SCATTERING PARAMETERS (T_A = 25°C)

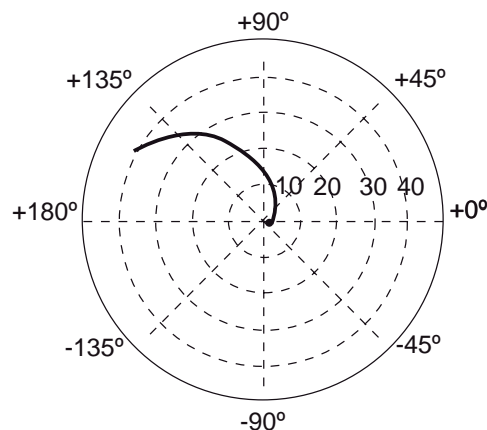
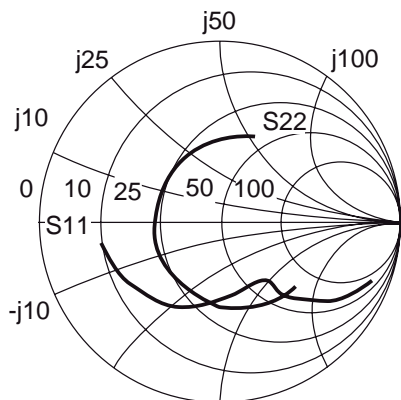

NE677M04

V_c = 5 V, I_c = 30 mA

FREQUENCY GHz	S ₁₁		S ₂₁		S ₁₂		S ₂₂		K	MAG ¹ (dB)
	MAG	ANG	MAG	ANG	MAG	ANG	MAG	ANG		
0.100	0.53	-41.03	40.66	151.83	0.01	79.56	0.89	-20.30	0.21	36.62
0.200	0.48	-73.66	32.81	132.70	0.02	64.08	0.75	-33.75	0.39	33.32
0.300	0.44	-97.50	26.31	119.35	0.02	56.29	0.63	-42.07	0.53	31.43
0.400	0.42	-114.52	21.49	109.81	0.02	53.44	0.56	-47.07	0.66	30.03
0.500	0.41	-127.00	18.03	102.57	0.02	53.31	0.50	-50.52	0.75	28.75
0.600	0.39	-139.82	15.28	96.73	0.03	53.08	0.43	-50.09	0.90	27.65
0.700	0.39	-147.57	13.34	91.78	0.03	54.05	0.41	-52.99	0.98	26.75
0.800	0.38	-153.47	11.83	87.64	0.03	55.02	0.40	-54.21	1.02	24.98
0.900	0.38	-159.31	10.62	83.69	0.03	55.65	0.39	-56.48	1.06	23.55
1.000	0.38	-163.26	9.64	80.25	0.04	56.16	0.38	-58.27	1.09	22.49
1.500	0.37	-179.14	6.55	64.91	0.05	58.22	0.37	-70.16	1.18	18.69
1.800	0.37	-171.01	5.50	56.83	0.06	57.93	0.38	-77.47	1.19	17.16
1.900	0.37	-168.30	5.22	54.20	0.06	57.51	0.39	-80.11	1.20	16.71
2.000	0.37	-165.83	4.96	51.65	0.06	57.41	0.39	-82.71	1.20	16.30
2.500	0.37	-152.63	3.99	39.13	0.08	54.90	0.43	-94.79	1.17	14.62
3.000	0.37	-139.29	3.33	27.15	0.09	51.63	0.46	-106.02	1.12	13.43
3.500	0.38	-125.14	2.85	15.43	0.11	47.27	0.50	-116.01	1.05	12.75
4.000	0.40	-111.70	2.49	4.05	0.13	42.60	0.54	-125.90	0.99	12.91
4.500	0.43	-99.67	2.19	-7.08	0.15	37.08	0.58	-136.09	0.91	11.79
5.000	0.46	-89.42	1.95	-17.99	0.16	31.31	0.61	-147.22	0.84	10.78
5.500	0.49	-80.22	1.74	-28.73	0.18	25.13	0.65	-158.70	0.78	9.86
6.000	0.51	-71.38	1.56	-39.19	0.20	18.62	0.68	-170.08	0.73	8.98

Note:

1. Gain Calculations:

$$MAG = \frac{|S_{21}|}{|S_{12}|} (K - \sqrt{K^2 - 1})$$

When $K \geq 1$, MAG is undefined and MSG values are used. $MSG = \frac{|S_{21}|}{|S_{12}|}$, $K = \frac{1 + |\Delta|^2 - |S_{11}|^2 - |S_{22}|^2}{2 |S_{12} S_{21}|}$, $\Delta = S_{11} S_{22} - S_{21} S_{12}$

MAG = Maximum Available Gain

MSG = Maximum Stable Gain

Life Support Applications

These NEC products are not intended for use in life support devices, appliances, or systems where the malfunction of these products can reasonably be expected to result in personal injury. The customers of CEL using or selling these products for use in such applications do so at their own risk and agree to fully indemnify CEL for all damages resulting from such improper use or sale.

EXCLUSIVE NORTH AMERICAN AGENT FOR NEC RF, MICROWAVE & OPTOELECTRONIC SEMICONDUCTORS

CEL CALIFORNIA EASTERN LABORATORIES • Headquarters • 4590 Patrick Henry Drive • Santa Clara, CA 95054-1817 • (408) 988-3500 • Telex 34-6393 • FAX (408) 988-0279
 DATA SUBJECT TO CHANGE WITHOUT NOTICE

Internet: <http://WWW.CEL.COM>

11/22/2002