

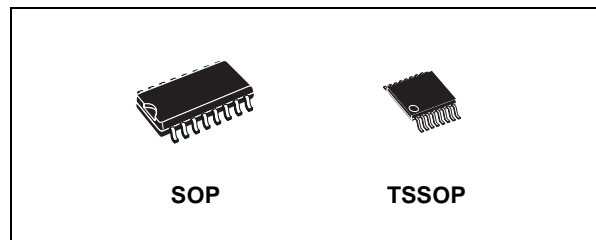

74LVX594

LOW VOLTAGE CMOS 8 BIT SHIFT REGISTER WITH OUTPUT REGISTER (5V TOLERANT INPUTS)

- HIGH SPEED :
 $t_{PD} = 5.5ns$ (TYP.) at $V_{CC} = 3.3V$
- 5V TOLERANT INPUTS
- INPUT VOLTAGE LEVEL :
 $V_{IL} = 0.8V$, $V_{IH} = 2V$ at $V_{CC} = 3V$
- LOW POWER DISSIPATION:
 $I_{CC} = 4 \mu A$ (MAX.) at $T_A = 25^\circ C$
- LOW NOISE:
 $V_{OLP} = 0.3V$ (TYP.) at $V_{CC} = 3.3V$
- SYMMETRICAL OUTPUT IMPEDANCE:
 $|I_{OH}| = I_{OL} = 4mA$ (MIN)
- BALANCED PROPAGATION DELAYS:
 $t_{PLH} \cong t_{PHL}$
- OPERATING VOLTAGE RANGE:
 $V_{CC}(OPR) = 2V$ to $3.6V$ (1.2V Data Retention)
- PIN AND FUNCTION COMPATIBLE WITH
 74 SERIES 594
- IMPROVED LATCH-UP IMMUNITY
- POWER DOWN PROTECTION ON INPUTS



ORDER CODES

PACKAGE	TUBE	T & R
SOP	74LVX594M	74LVX594MTR
TSSOP		74LVX594TTR

DESCRIPTION

The 74LVX594 is a low voltage CMOS 8 BIT SHIFT REGISTER WITH OUTPUT REGISTER fabricated with sub-micron silicon gate and double-layer metal wiring C²MOS technology. It is ideal for low power, battery operated and low noise 3.3V applications.

This device contains an 8-bit serial-in, parallel-out shift register that feeds an 8-bit D-type storage register. Separate clocks and direct overriding clear (SCLR, RCLR) are provided for both the shift

register and the storage register. A serial (QH') output is provided for cascading purposes. Both the shift register and storage register use positive-edge triggered clocks. If the clocks are connected together, the shift register state will always be one clock pulse ahead of the storage register.

Power down protection is provided on all inputs and 0 to 7V can be accepted on inputs with no regard to the supply voltage. This device can be used to interface 5V to 3V system. It combines high speed performance with the true CMOS low power consumption.

All inputs and outputs are equipped with protection circuits against static discharge, giving them 2KV ESD immunity and transient excess voltage.

PIN CONNECTION AND IEC LOGIC SYMBOLS

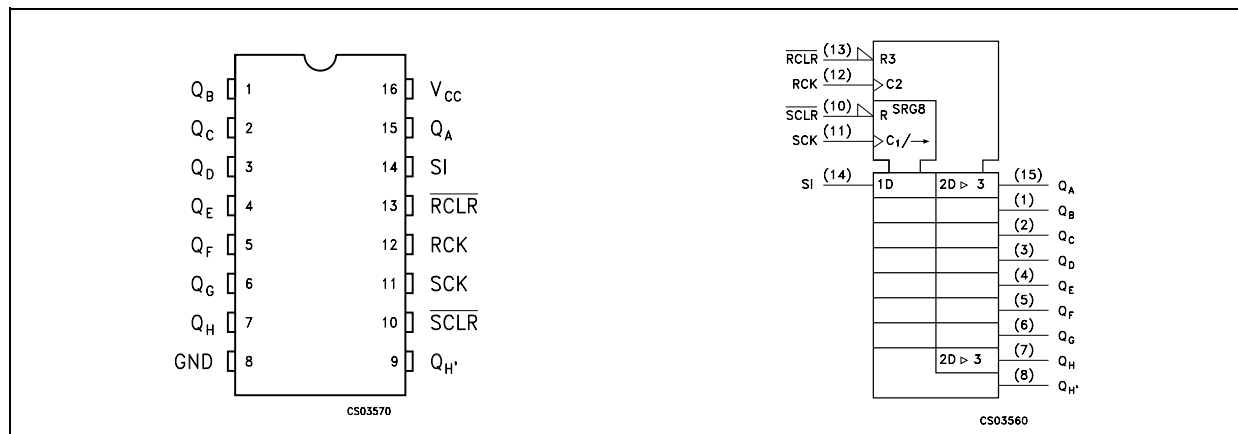

INPUT EQUIVALENT CIRCUIT

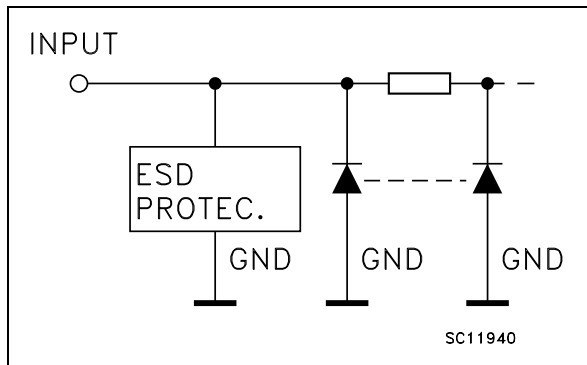

PIN DESCRIPTION

PIN No	SYMBOL	NAME AND FUNCTION
1, 2, 3, 4, 5, 6, 7, 15	QA to QH	Data Outputs
9	QH'	Serial Data Output
10	SCLR	Shift Register Clear Input
11	SCK	Shift Register Clock Input
13	RCLR	Storage Register Clear Input
14	SI	Serial Data Input
12	RCK	Storage Register Clock Input
8	GND	Ground (0V)
16	V _{CC}	Positive Supply Voltage

TRUTH TABLE

INPUTS					OUTPUTS
SI	SCK	$\overline{\text{SCLR}}$	RCK	$\overline{\text{RCLR}}$	
X	X	L	X	X	SHIFT REGISTER IS CLEAR
L		H	X	X	FIRST STAGE OF SHIFT REGISTER GOES LOW OTHER STAGES STORE THE DATA OF PREVIOUS STAGE, RESPECTIVELY
H		H	X	X	FIRST STAGE OF SHIFT REGISTER GOES HIGH OTHER STAGES STORE THE DATA OF PREVIOUS STAGE, RESPECTIVELY
L		H	X	X	SHIFT REGISTER STATE IS NOT CHANGED
X	X	X	X	L	STORAGE REGISTER IS CLEARED
X	X	X		H	SHIFT REGISTER DATA IS STORED IN THE STORAGE REGISTER
X	X	X		H	STORAGE REGISTER STATE IS NOT CHANGED

X : Don't Care

LOGIC DIAGRAM

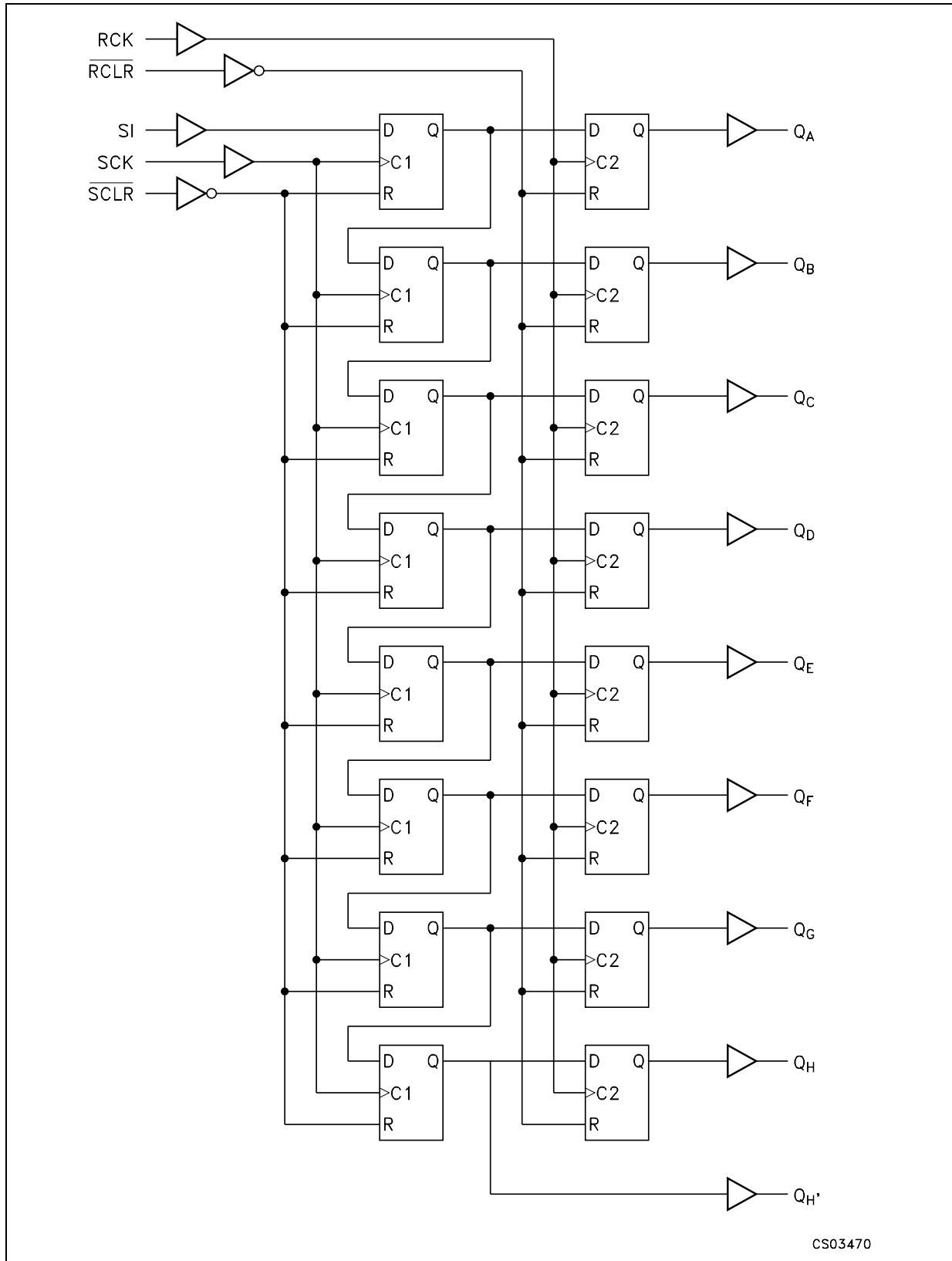

This logic diagram has not been used to estimate propagation delays



TIMING CHART

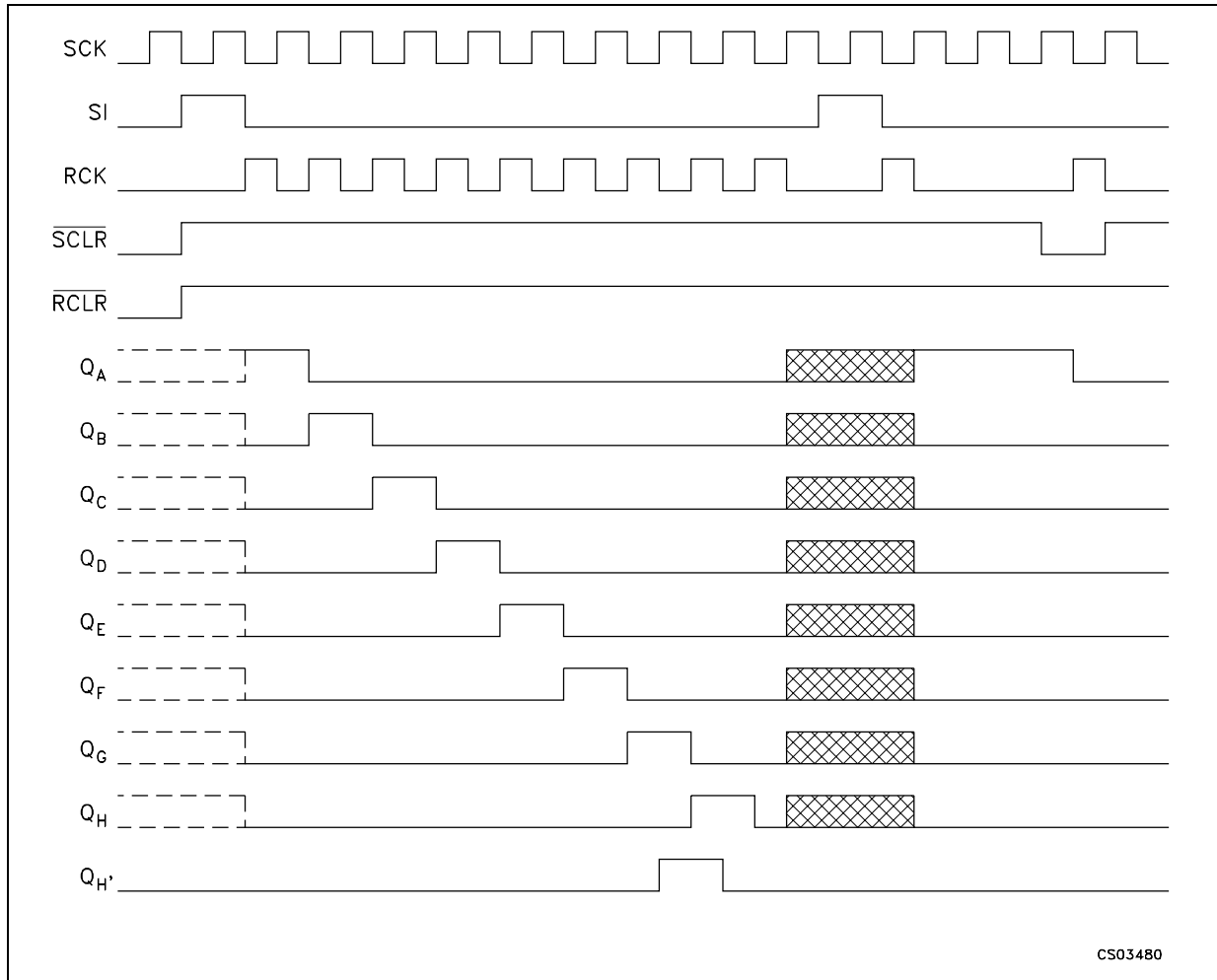

ABSOLUTE MAXIMUM RATINGS

Symbol	Parameter	Value	Unit
V_{CC}	Supply Voltage	-0.5 to +7.0	V
V_I	DC Input Voltage	-0.5 to +7.0	V
V_O	DC Output Voltage	-0.5 to $V_{CC} + 0.5$	V
I_{IK}	DC Input Diode Current	- 20	mA
I_{OK}	DC Output Diode Current	± 20	mA
I_O	DC Output Current	± 25	mA
I_{CC} or I_{GND}	DC V_{CC} or Ground Current	± 50	mA
T_{stg}	Storage Temperature	-65 to +150	$^{\circ}C$
T_L	Lead Temperature (10 sec)	300	$^{\circ}C$

Absolute Maximum Ratings are those values beyond which damage to the device may occur. Functional operation under these conditions is not implied.

RECOMMENDED OPERATING CONDITIONS

Symbol	Parameter	Value	Unit
V_{CC}	Supply Voltage (note 1)	2 to 3.6	V
V_I	Input Voltage	0 to 5.5	V
V_O	Output Voltage	0 to V_{CC}	V
T_{op}	Operating Temperature	-55 to 125	°C
dt/dv	Input Rise and Fall Time (note 2) ($V_{CC} = 3.3V$)	0 to 100	ns/V

1) Truth Table guaranteed: 1.2V to 3.6V

2) V_{IN} from 0.8V to 2.0V

DC SPECIFICATIONS

Symbol	Parameter	Test Condition		Value						Unit	
		V_{CC} (V)		$T_A = 25^\circ C$			-40 to $85^\circ C$		-55 to $125^\circ C$		
				Min.	Typ.	Max.	Min.	Max.	Min.		Max.
V_{IH}	High Level Input Voltage	2.0		1.5			1.5		1.5		V
		3.0		2.0			2.0		2.0		
		3.6		2.4			2.4		2.4		
V_{IL}	Low Level Input Voltage	2.0				0.5		0.5		0.5	V
		3.0				0.8		0.8		0.8	
		3.6				0.8		0.8		0.8	
V_{OH}	High Level Output Voltage	2.0	$I_O = -50 \mu A$	1.9	2.0		1.9		1.9		V
		3.0	$I_O = -50 \mu A$	2.9	3.0		2.9		2.9		
		3.0	$I_O = -4 mA$	2.58			2.48		2.4		
V_{OL}	Low Level Output Voltage	2.0	$I_O = 50 \mu A$		0.0	0.1		0.1		0.1	V
		3.0	$I_O = 50 \mu A$		0.0	0.1		0.1		0.1	
		3.0	$I_O = 4 mA$			0.36		0.44		0.55	
I_I	Input Leakage Current	3.6	$V_I = 5V$ or GND			± 0.1		± 1		± 1	μA
I_{CC}	Quiescent Supply Current	3.6	$V_I = V_{CC}$ or GND			4		40		40	μA

DYNAMIC SWITCHING CHARACTERISTICS

Symbol	Parameter	Test Condition		Value						Unit	
		V_{CC} (V)		$T_A = 25^\circ C$			-40 to $85^\circ C$		-55 to $125^\circ C$		
				Min.	Typ.	Max.	Min.	Max.	Min.		Max.
V_{OLP}	Dynamic Low Voltage Quiet Output (note 1, 2)	3.3	$C_L = 50 pF$		0.3	0.5					V
V_{OLV}				-0.5	-0.3						
V_{IHD}	Dynamic High Voltage Input (note 1, 3)	3.3		2							
V_{ILD}	Dynamic Low Voltage Input (note 1, 3)	3.3				0.8					

1) Worst case package.

2) Max number of outputs defined as (n). Data inputs are driven 0V to 3.3V, (n-1) outputs switching and one output at GND.

3) Max number of data inputs (n) switching. (n-1) switching 0V to 3.3V. Inputs under test switching: 3.3V to threshold (V_{ILD}), 0V to threshold (V_{IHD}), $f=1MHz$.

AC ELECTRICAL CHARACTERISTICS (Input $t_r = t_f = 3\text{ns}$)

Symbol	Parameter	Test Condition		Value								Unit
		V_{CC} (V)	C_L (pF)	$T_A = 25^\circ\text{C}$			-40 to 85°C		-55 to 125°C			
				Min.	Typ.	Max.	Min.	Max.	Min.	Max.		
t_{PLH} t_{PHL}	Propagation Delay Time (RCK - Qn)	2.7	15		5.5	9.5	1.0	10.0	1.0	10.0	ns	
		2.7	50		9.0	13.0	1.0	14.5	1.0	14.5		
		3.3 ^(*)	15		4.9	8.2	1.0	8.8	1.0	8.8		
		3.3 ^(*)	50		8.1	11.9	1.0	13.1	1.0	13.1		
t_{PLH} t_{PHL}	Propagation Delay Time (SCK - QH')	2.7	15		6.5	11.0	1.0	12.5	1.0	12.5	ns	
		2.7	50		9.2	14.0	1.0	16.0	1.0	16.0		
		3.3 ^(*)	15		5.5	9.2	1.0	9.9	1.0	9.9		
		3.3 ^(*)	50		8.4	12.5	1.0	13.9	1.0	13.9		
t_{PHL}	Propagation Delay Time (RCLR - Qn)	2.7	15		7.3	11.0	1.0	13.0	1.0	13.0	ns	
		2.7	50		10.5	14.5	1.0	16.0	1.0	16.0		
		3.3 ^(*)	15		6.0	9.8	1.0	10.6	1.0	10.6		
		3.3 ^(*)	50		9.0	13.1	1.0	14.4	1.0	14.4		
t_{PLH} t_{PHL}	Propagation Delay Time (SCLR - QH')	2.7	15		6.3	10.5	1.0	12.0	1.0	12.0	ns	
		2.7	50		9.0	13.5	1.0	15.5	1.0	15.5		
		3.3 ^(*)	15		5.6	9.2	1.0	10.0	1.0	10.0		
		3.3 ^(*)	50		8.5	12.4	1.0	14.0	1.0	14.0		
f_{MAX}	Maximum Clock Frequency	2.7	15		70	110		60		60	MHz	
		2.7	50		40	90		35		35		
		3.3 ^(*)	15		80	120		70		70		
		3.3 ^(*)	50		55	105		50		50		
$t_{W(H)}$	Minimum Pulse Width (SCK, RCK)	2.7	50		6.5			6.5		6.5	ns	
		3.3 ^(*)	50		5.5			5.5		5.5		
$t_{W(L)}$	Minimum Pulse Width (SCLR, RCLR)	2.7	50		5.0			5.0		5.0	ns	
		3.3 ^(*)	50		5.0			5.0		5.0		
t_s	Minimum Set-Up Time (SI - CCK)	2.7	50		3.5			3.5		3.5	ns	
		3.3 ^(*)	50		3.0			3.0		3.0		
t_s	Minimum Set - Up Time (SCK, RCK)	2.7	50		9.0			9.0		9.0	ns	
		3.3 ^(*)	50		8.5			8.5		8.5		
t_s	Minimum Set - Up Time (SCLR - RCK)	2.7	50		8.0			8.0		8.0	ns	
		3.3 ^(*)	50		7.5			7.5		7.5		
t_h	Minimum Hold Time	2.7	50		1.5			1.5		1.5	ns	
		3.3 ^(*)	50		1.5			1.5		1.5		
t_{REM}	Minimum Clear-Removal Time	2.7	50		3.0			3.0		3.0	ns	
		3.3 ^(*)	50		3.0			3.0		3.0		
t_{OSLH} t_{OSHL}	Output To Output Skew Time (note 1, 2)	2.7	50			0.5	1.0		1.5		1.5	ns
		3.3 ^(*)	50			0.5	1.0		1.5		1.5	

1) Skew is defined as the absolute value of the difference between the actual propagation delay for any two outputs of the same device switching in the same direction, either HIGH or LOW

2) Parameter guaranteed by design

(*) Voltage range is $3.3\text{V} \pm 0.3\text{V}$

CAPACITIVE CHARACTERISTICS

Symbol	Parameter	Test Condition		Value						Unit	
		V _{CC} (V)		T _A = 25°C			-40 to 85°C		-55 to 125°C		
				Min.	Typ.	Max.	Min.	Max.	Min.		Max.
C _{IN}	Input Capacitance	3.3			7	10		10		10	pF
C _{OUT}	Output Capacitance	3.3			9						pF
C _{PD}	Power Dissipation Capacitance (note 1)	3.3	f _{IN} = 10MHz		55						pF

1) C_{PD} is defined as the value of the IC's internal equivalent capacitance which is calculated from the operating current consumption without load. (Refer to Test Circuit). Average operating current can be obtained by the following equation. $I_{CC(opr)} = C_{PD} \times V_{CC} \times f_{IN} + I_{CC}$

TEST CIRCUIT

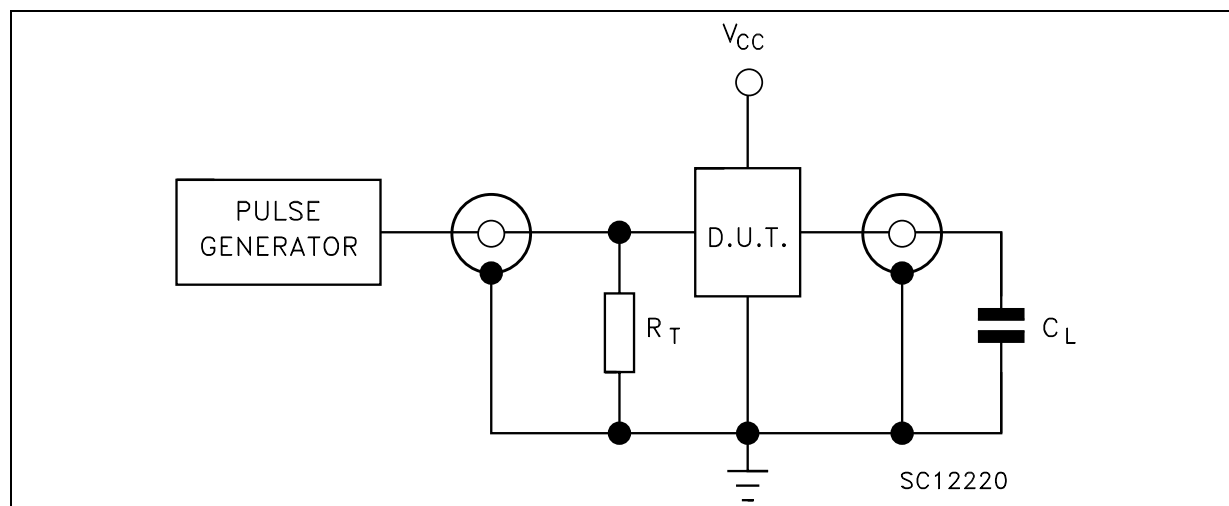

C_L = 15/50pF or equivalent (includes jig and probe capacitance)
R_T = Z_{OUT} of pulse generator (typically 50Ω)

WAVEFORM 1 : PROPAGATION DELAYS, SETUP AND HOLD TIMES (f=1MHz; 50% duty cycle)

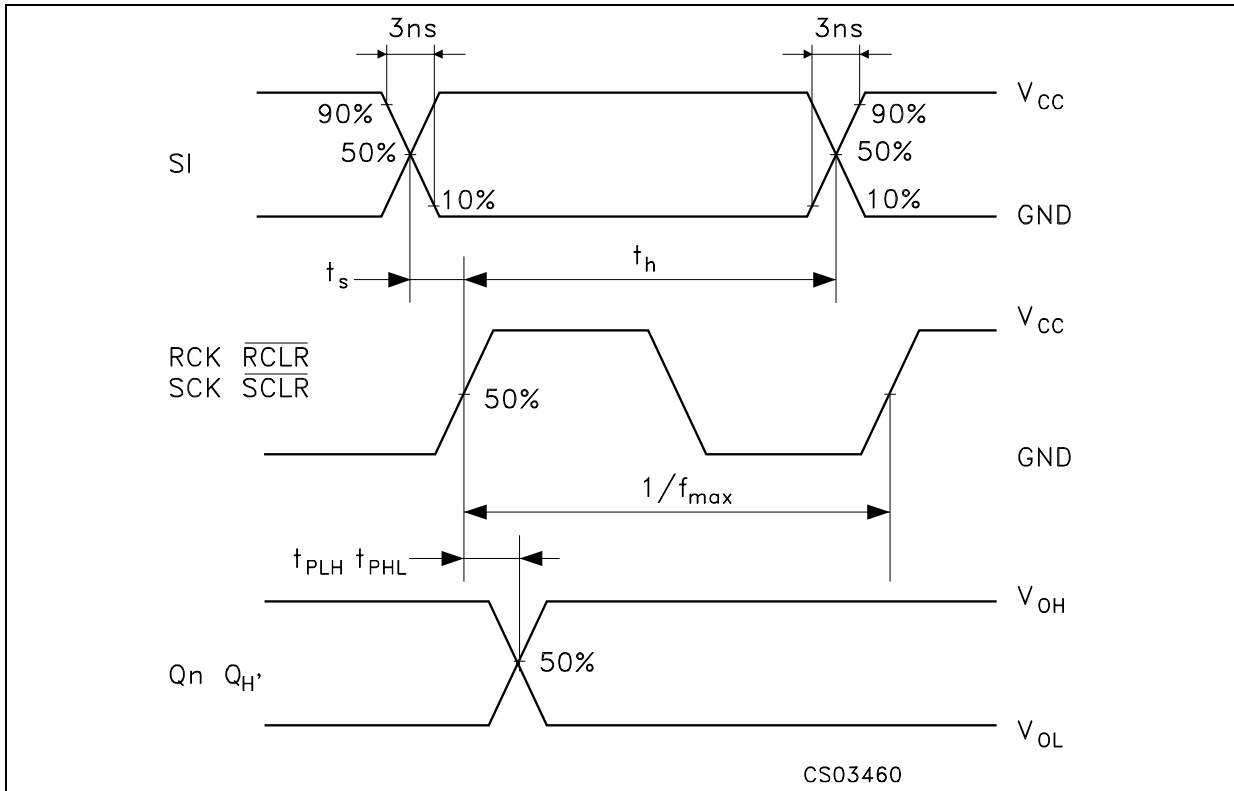

WAVEFORM 2: MINIMUM PULSE WIDTH (f=1MHz; 50% duty cycle)

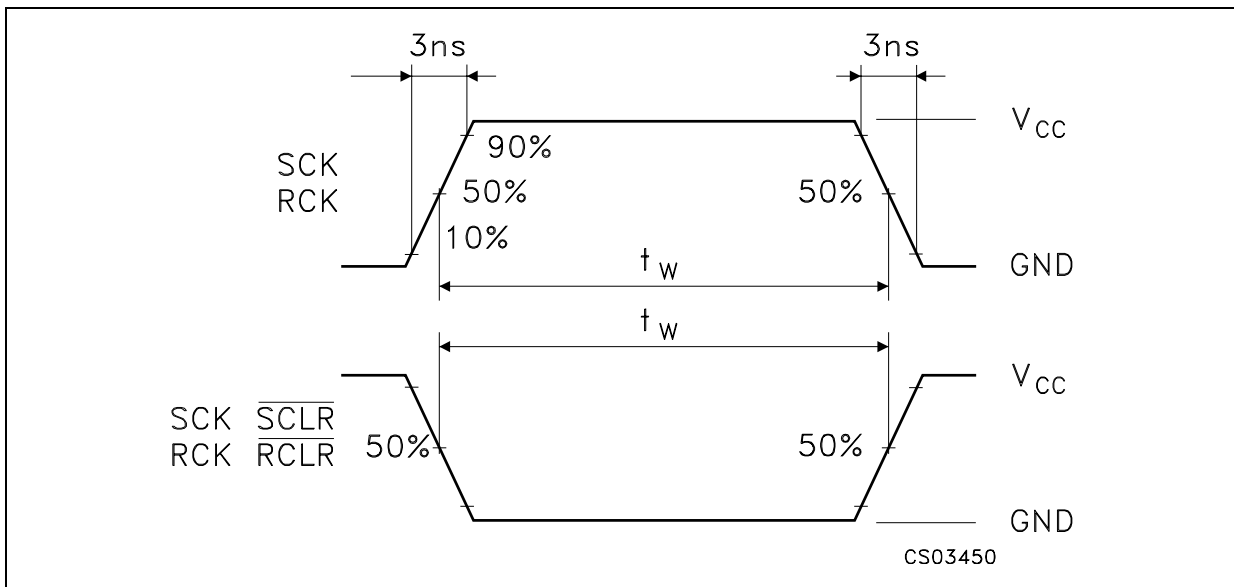

SO-16 MECHANICAL DATA

DIM.	mm.			inch		
	MIN.	TYP.	MAX.	MIN.	TYP.	MAX.
A			1.75			0.068
a1	0.1		0.2	0.003		0.007
a2			1.65			0.064
b	0.35		0.46	0.013		0.018
b1	0.19		0.25	0.007		0.010
C		0.5			0.019	
c1	45° (typ.)					
D	9.8		10	0.385		0.393
E	5.8		6.2	0.228		0.244
e		1.27			0.050	
e3		8.89			0.350	
F	3.8		4.0	0.149		0.157
G	4.6		5.3	0.181		0.208
L	0.5		1.27	0.019		0.050
M			0.62			0.024
S	8° (max.)					

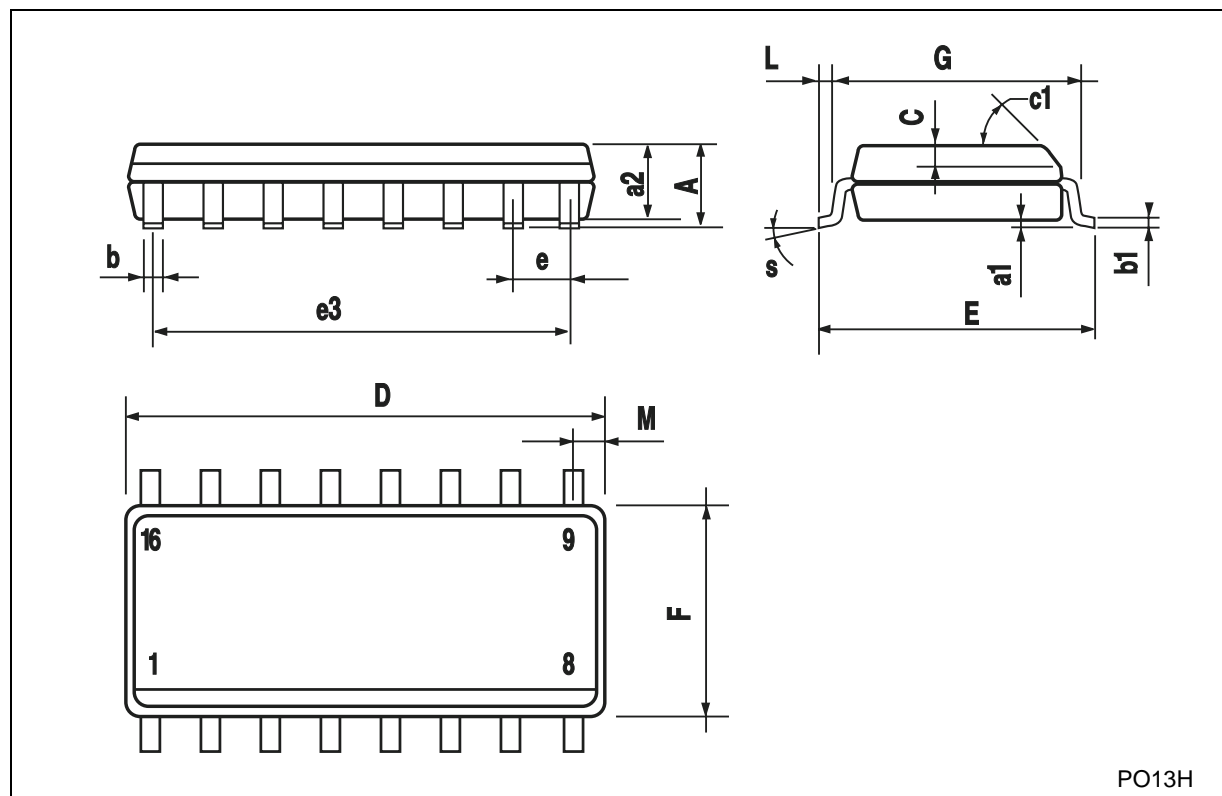

TSSOP16 MECHANICAL DATA

DIM.	mm.			inch		
	MIN.	TYP	MAX.	MIN.	TYP.	MAX.
A			1.2			0.047
A1	0.05		0.15	0.002	0.004	0.006
A2	0.8	1	1.05	0.031	0.039	0.041
b	0.19		0.30	0.007		0.012
c	0.09		0.20	0.004		0.0089
D	4.9	5	5.1	0.193	0.197	0.201
E	6.2	6.4	6.6	0.244	0.252	0.260
E1	4.3	4.4	4.48	0.169	0.173	0.176
e		0.65 BSC			0.0256 BSC	
K	0°		8°	0°		8°
L	0.45	0.60	0.75	0.018	0.024	0.030

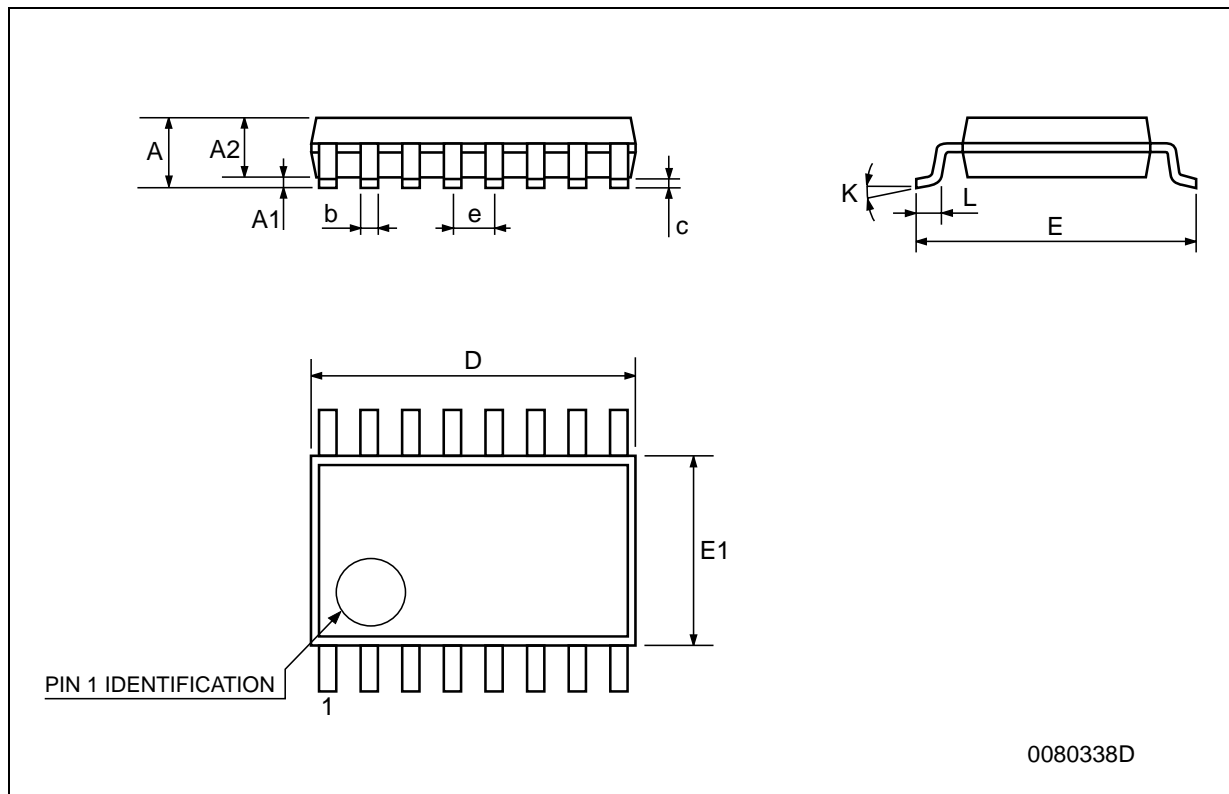

Information furnished is believed to be accurate and reliable. However, STMicroelectronics assumes no responsibility for the consequences of use of such information nor for any infringement of patents or other rights of third parties which may result from its use. No license is granted by implication or otherwise under any patent or patent rights of STMicroelectronics. Specifications mentioned in this publication are subject to change without notice. This publication supersedes and replaces all information previously supplied. STMicroelectronics products are not authorized for use as critical components in life support devices or systems without express written approval of STMicroelectronics.

© The ST logo is a registered trademark of STMicroelectronics

© 2001 STMicroelectronics - Printed in Italy - All Rights Reserved
STMicroelectronics GROUP OF COMPANIES

Australia - Brazil - China - Finland - France - Germany - Hong Kong - India - Italy - Japan - Malaysia - Malta - Morocco
Singapore - Spain - Sweden - Switzerland - United Kingdom

© <http://www.st.com>

