

## RF & MICROWAVE TRANSISTORS AVIONICS APPLICATIONS

- $P_{OUT} = 500\text{ W MIN. WITH } 8.5\text{ dB MIN. GAIN}$
- 10:1 LOAD VSWR CAPABILITY @  $10\mu\text{S.}, 1\% \text{ DUTY}$
- SIXPAC™ HERMETIC METAL/CERAMIC PACKAGE
- EMITTER SITE BALLASTED OVERLAY GEOMETRY
- REFRACTORY/GOLD METALLIZATION
- LOW THERMAL RESISTANCE
- INTERNAL INPUT/OUTPUT MATCHING
- CHARACTERIZED UNDER  $32\mu\text{S.}, 2\% \text{ DUTY CYCLE PULSE CONDITIONS}$

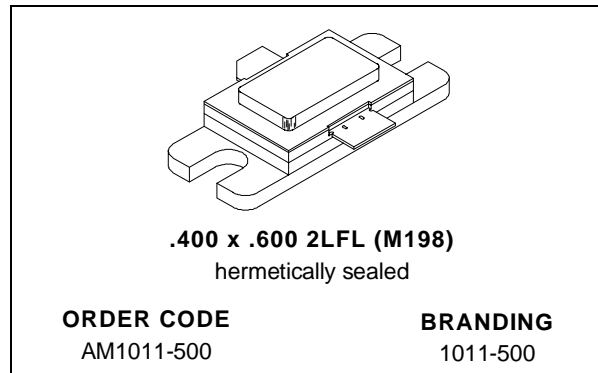

### DESCRIPTION

The AM1011-500 device is a high power Class C transistor specifically designed for L-Band Avionic applications involving high pulse burst duty cycles.

This device is capable of operation over a wide range of pulse widths, duty cycles, and temperatures. Low RF thermal resistance and computerized automatic wire bonding techniques ensure high reliability and product consistency.

The AM1011-500 is supplied in the SIXPAC™ Hermetic metal/ceramic package with internal input/output matching structures.

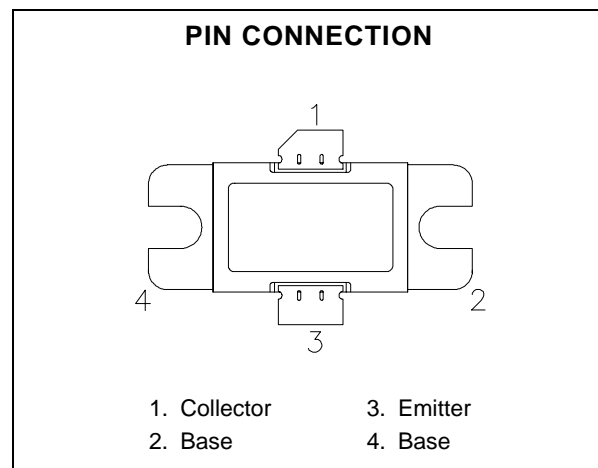

### ABSOLUTE MAXIMUM RATINGS ( $T_{case} = 25^{\circ}\text{C}$ )

Symbol	Parameter	Value	Unit
$P_{DISS}$	Power Dissipation* ( $T_C \leq 100^{\circ}\text{C}$ )	1,360	W
$I_C$	Device Current*	27	A
$V_{CC}$	Collector-Supply Voltage*	55	V
$T_J$	Junction Temperature (Pulsed RF Operation)	250	$^{\circ}\text{C}$
$T_{STG}$	Storage Temperature	- 65 to +200	$^{\circ}\text{C}$

### THERMAL DATA

$R_{TH(j-c)}$	Junction-Case Thermal Resistance*	0.11	$^{\circ}\text{C/W}$
---------------	-----------------------------------	------	----------------------

\*Applies only to rated RF amplifier operation

ELECTRICAL SPECIFICATIONS (T<sub>case</sub> = 25°C)

STATIC

Symbol	Test Conditions		Value			Unit
			Min.	Typ.	Max.	
BV <sub>CBO</sub>	I <sub>C</sub> = 50 mA	I <sub>E</sub> = 0 mA	70	—	—	V
BV <sub>EBO</sub>	I <sub>E</sub> = 30 mA	I <sub>C</sub> = 0 mA	3.0	—	—	V
BV <sub>CES</sub>	I <sub>C</sub> = 50 mA	V <sub>BE</sub> = 0 V	70	—	—	V
I <sub>CES</sub>	V <sub>BE</sub> = 0 V	V <sub>CE</sub> = 50 V	—	—	40	mA
h <sub>FE</sub>	V <sub>CE</sub> = 5 V	I <sub>C</sub> = 1.0 A	10	—	200	—

DYNAMIC

Symbol	Test Conditions			Value			Unit
				Min.	Typ.	Max.	
P <sub>OUT</sub>	f = 1090 MHz	P <sub>IN</sub> = 70 W	V <sub>CC</sub> = 50 V	500	—	—	W
hc	f = 1090 MHz	P <sub>OUT</sub> = 500 W	V <sub>CC</sub> = 50 V	40	—	—	%
G <sub>P</sub>	f = 1090 MHz	P <sub>OUT</sub> = 500 W	V <sub>CC</sub> = 50 V	8.5	—	—	dB
Load Mismatch	P <sub>OUT</sub> = 500 W Peak F = 1090MHz V <sub>CC</sub> = 50 V	VSWR = 10:1, 10μS, 1% Duty VSWR = 5:1, 32μS, 2% Duty		No Degradation in Output Power			

Note: Pulse Width = 32μSec, Duty Cycle = 2%

TYPICAL PERFORMANCE

POWER OUTPUT & COLLECTOR EFFICIENCY vs POWER INPUT

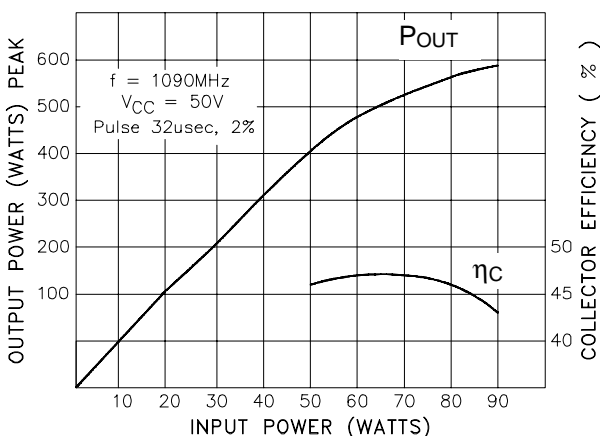

POWER OUTPUT & COLLECTOR EFFICIENCY vs POWER INPUT

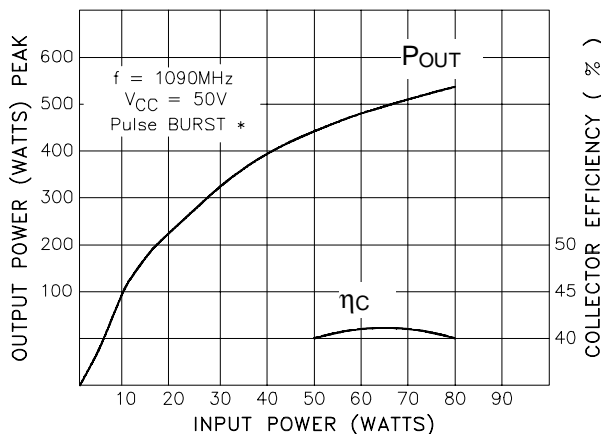

\* Pulse Burst conditions:  
 128 μSec train, 0.5 μSec on,  
 0.5 μSec off; with a period of 6.4 msec.

IMPEDANCE DATA

FREQ.	Z <sub>IN</sub> (Ω)	Z <sub>CL</sub> (Ω)
1030 MHz	4.35 + j 6.97	1.38 - j 4.08
1090 MHz	4.38 + j 2.75	.874 - j 3.55
1120 MHz	4.69 + j 2.95	1.3 - j 4.97

P<sub>IN</sub> = 70W

V<sub>CC</sub> = 50V

TEST CIRCUIT

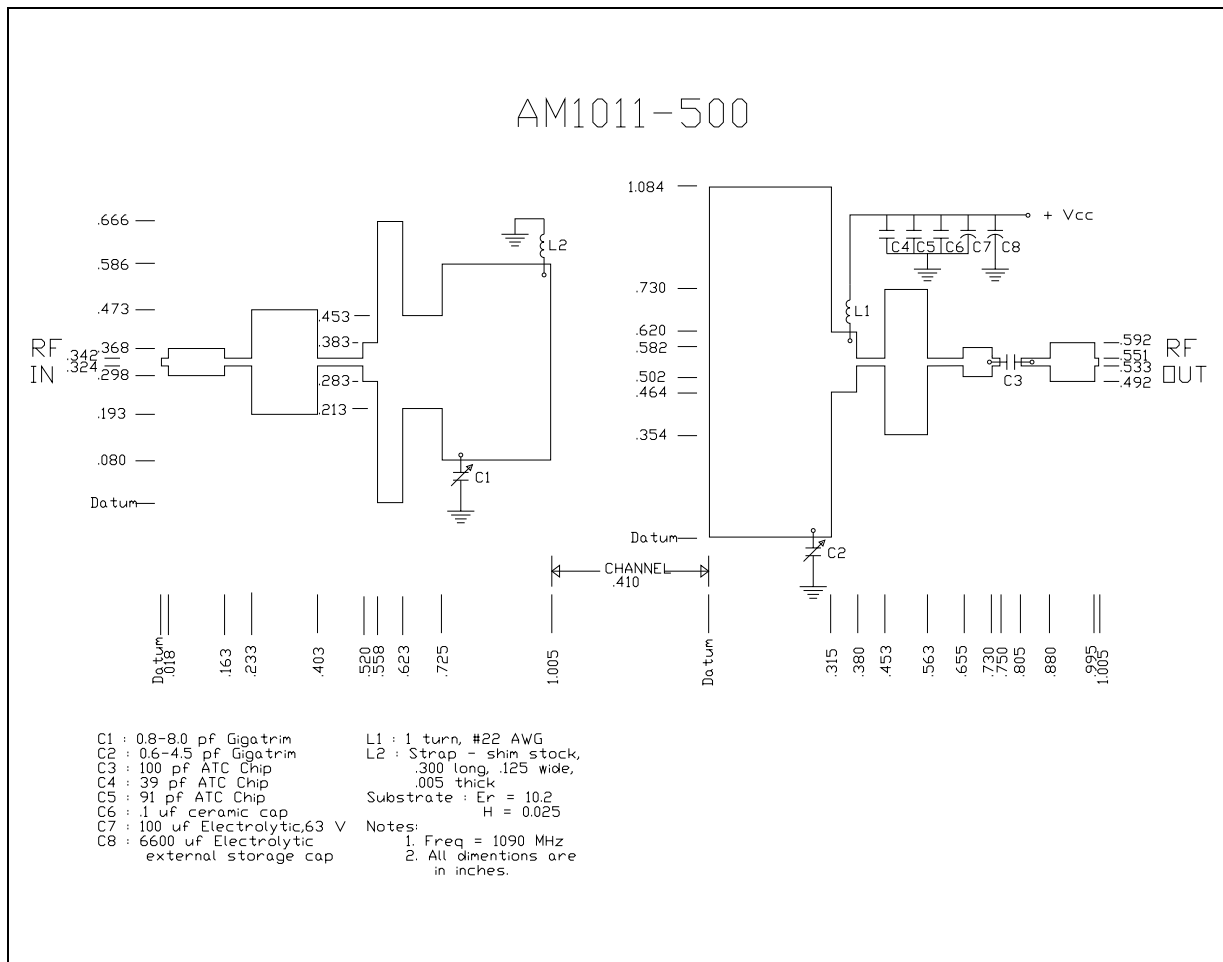

PACKAGE MECHANICAL DATA

Ref.: Dwg. No. 12-0198 rev. A

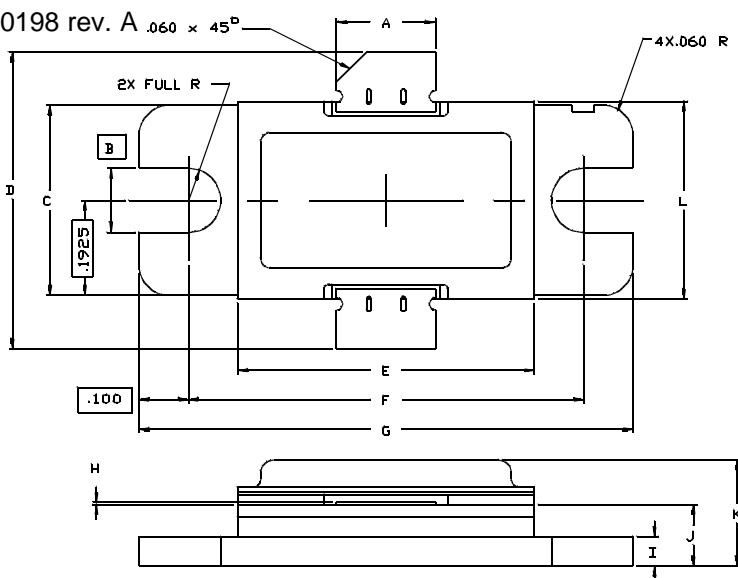

SGS-THOMSON MICROELECTRONICS		CONT'D			
	MINIMUM Inches/mm	MAXIMUM Inches/mm		MINIMUM Inches/mm	MAXIMUM Inches/mm
A	.195/4,95	.205/5,21	K		.230/5,84
B	.130/3,30		L	.393/9,98	.407/10,34
C	.380/9,65	.390/9,91			
D	.570/14,48				
E	.593/15,06	.607/15,42			
F	.790/20,07	.810/20,57			
G	.995/25,27	1.005/25,53			
H	.002/0,05	.006/0,15			
I	.055/1,40	.065/1,65			
J	.110/2,79	.130/3,30			

Information furnished is believed to be accurate and reliable. However, SGS-THOMSON Microelectronics assumes no responsibility for the consequences of use of such information nor for any infringement of patents or other rights of third parties which may result from its use. No license is granted by implication or otherwise under any patent or patent rights of SGS-THOMSON Microelectronics. Specifications mentioned in this publication are subject to change without notice. This publication supersedes and replaces all information previously supplied. SGS-THOMSON Microelectronics products are not authorized for use as critical components in life support devices or systems without express written approval of SGS-THOMSON Microelectronics.

©1995 SGS-THOMSON Microelectronics - All Rights Reserved

SGS-THOMSON Microelectronics GROUP OF COMPANIES

Australia - Brazil - France - Germany - Hong Kong - Italy - Japan - Korea - Malaysia - Malta - Morocco - The Netherlands - Singapore - Spain - Sweden - Switzerland - Taiwan - Thailand - United Kingdom - U.S.A.