



BUT11A

HIGH VOLTAGE FAST-SWITCHING NPN POWER TRANSISTOR

- STMicroelectronics PREFERRED SALESTYPE
- NPN TRANSISTOR
- HIGH VOLTAGE CAPABILITY
- FAST SWITCHING SPEED

APPLICATIONS:

- FLYBACK AND FORWARD SINGLE TRANSISTOR LOW POWER CONVERTERS

DESCRIPTION

The BUT11A is a silicon Multiepitaxial Mesa NPN transistor in Jedec TO-220 plastic package, particularly intended for switching application.

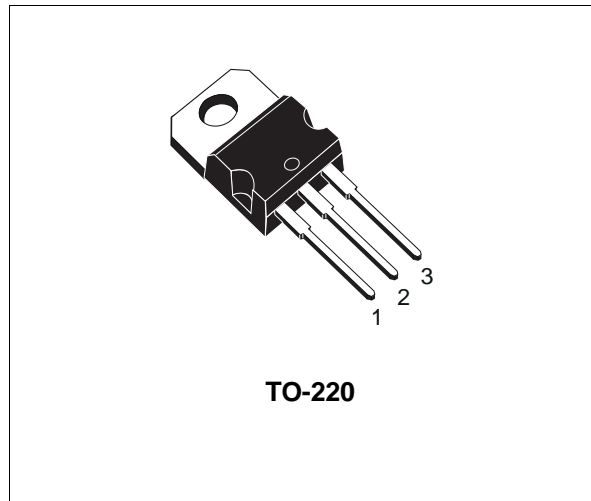

TO-220

INTERNAL SCHEMATIC DIAGRAM

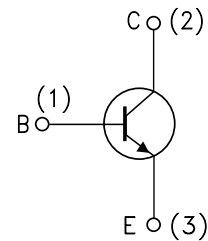

ABSOLUTE MAXIMUM RATINGS

Symbol	Parameter	Value	Unit
V_{CES}	Collector-Emitter Voltage ($V_{BE} = 0$ V)	1000	V
V_{CEO}	Collector-Emitter Voltage ($I_B = 0$)	450	V
V_{EBO}	Emitter-Base Voltage ($I_C = 0$)	9	V
I_C	Collector Current	5	A
I_{CM}	Collector Peak Current ($t_p < 5$ ms)	10	A
I_B	Base Current	2	A
I_{BM}	Base Peak Current ($t_p < 5$ ms)	4	A
P_{tot}	Total Power Dissipation at $T_c \leq 25$ °C	83	W
T_{stg}	Storage Temperature	-65 to 150	°C
T_j	Max. Operating Junction Temperature	150	°C

BUT11A

THERMAL DATA

$R_{thj-case}$	Thermal Resistance Junction-case	Max	1.5	$^{\circ}C/W$
----------------	----------------------------------	-----	-----	---------------

ELECTRICAL CHARACTERISTICS ($T_{case} = 25^{\circ}C$ unless otherwise specified)

Symbol	Parameter	Test Conditions	Min.	Typ.	Max.	Unit
I_{CES}	Collector Cut-off Current ($V_{BE} = 0$)	$V_{CE} = \text{rated } V_{CES}$ at $T_c = 125^{\circ}C$			1 2	mA mA
I_{EBO}	Emitter Cut-off Current ($I_C = 0$)	$I_C = 0$ $V_{BE} = 9 V$			10	mA
$V_{CEO(sus)*}$	Collector-emitter Sustaining Voltage ($I_B = 0$)	$I_{B(off)} = 0$ $I_C = 100 \text{ mA}$	450			V
$V_{CE(sat)*}$	Collector-emitter Saturation Voltage	$I_C = 2.5 A$ $I_B = 0.5 A$			1.5	V
$V_{BE(sat)*}$	Base-emitter Saturation Voltage	$I_C = 2.5 A$ $I_B = 0.5 A$			1.3	V
t_{on} t_s t_f	RESISTIVE LOAD Turn on Time Storage Time Fall Time	$I_C = 2.5 A$ $V_{CC} = 250 V$ $I_B = -I_{B2} = 0.5 A$			1 4 0.8	μs μs μs

* Pulsed: Pulse duration = 300 μs , duty cycle 1.5 %.

TO-220 MECHANICAL DATA

DIM.	mm			inch		
	MIN.	TYP.	MAX.	MIN.	TYP.	MAX.
A	4.40		4.60	0.173		0.181
C	1.23		1.32	0.048		0.052
D	2.40		2.72	0.094		0.107
E	0.49		0.70	0.019		0.027
F	0.61		0.88	0.024		0.034
F1	1.14		1.70	0.044		0.067
F2	1.14		1.70	0.044		0.067
G	4.95		5.15	0.194		0.202
G1	2.40		2.70	0.094		0.106
H2	10.00		10.40	0.394		0.409
L2		16.40			0.645	
L4	13.00		14.00	0.511		0.551
L5	2.65		2.95	0.104		0.116
L6	15.25		15.75	0.600		0.620
L7	6.20		6.60	0.244		0.260
L9	3.50		3.93	0.137		0.154
M		2.60			0.102	
DIA.	3.75		3.85	0.147		0.151

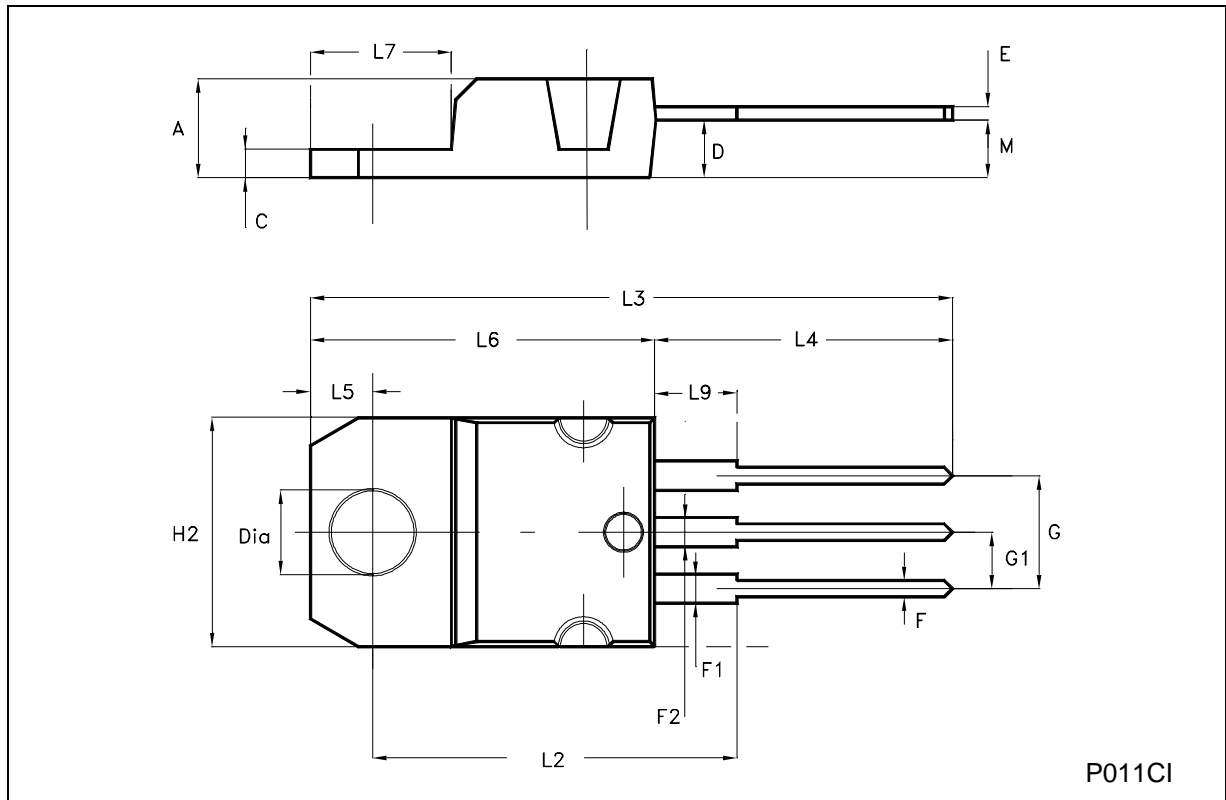

P011CI

Information furnished is believed to be accurate and reliable. However, STMicroelectronics assumes no responsibility for the consequences of use of such information nor for any infringement of patents or other rights of third parties which may result from its use. No license is granted by implication or otherwise under any patent or patent rights of STMicroelectronics. Specification mentioned in this publication are subject to change without notice. This publication supersedes and replaces all information previously supplied. STMicroelectronics products are not authorized for use as critical components in life support devices or systems without express written approval of STMicroelectronics.

The ST logo is a trademark of STMicroelectronics

© 2003 STMicroelectronics – Printed in Italy – All Rights Reserved

STMicroelectronics GROUP OF COMPANIES

Australia - Brazil - Canada - China - Finland - France - Germany - Hong Kong - India - Israel - Italy - Japan - Malaysia - Malta - Morocco - Singapore - Spain - Sweden - Switzerland - United Kingdom - United States.

<http://www.st.com>