

QUAD DARLINGTON SWITCH

- FOUR NON INVERTING INPUTS WITH ENABLE
- OUTPUT VOLTAGE UP TO 60 V
- OUTPUT CURRENT UP TO 1.8 A
- VERY LOW SATURATION VOLTAGE
- TTL COMPATIBLE INPUTS
- INTEGRAL FAST RECIRCULATION DIODES

DESCRIPTION

The L6221 monolithic quad darlington switch is designed for high current, high voltage switching applications. Each of the four switches is controlled by a logic input and all four are controlled by a common enable input. All inputs are TTL-compatible for direct connection to logic circuits.

Each switch consists of an open-collector darlington transistor plus a fast diode for switching applications with inductive device loads. The emitters of the four switches are commoned. Any number of inputs and

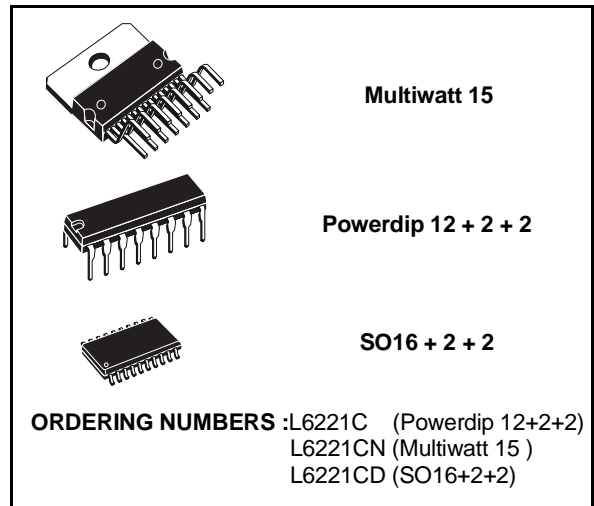

outputs of the same device may be paralleled. Three versions are available : the L6221C mounted in a Powerdip 12 + 2 + 2 package and the L6221CN mounted in a 15--lead Multiwatt package, the L6221CD in SO16+2+2 package.

BLOCK DIAGRAM

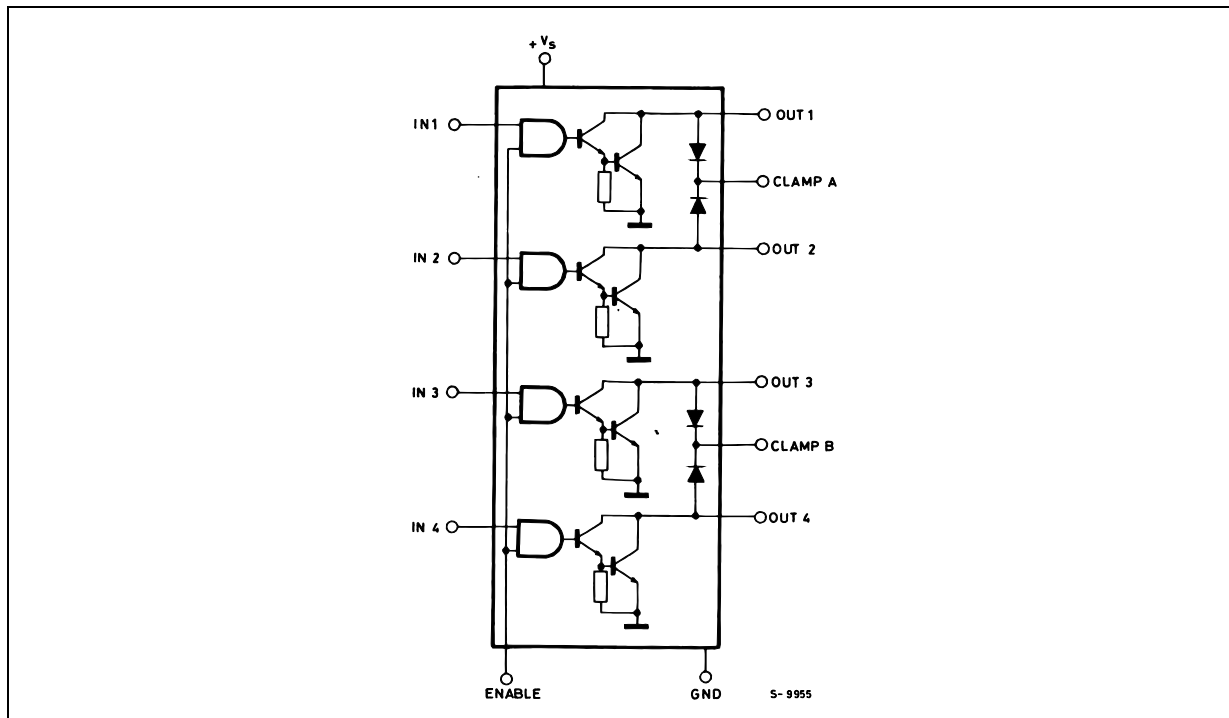

L6221C-L6221CN-L6221CD

THERMAL DATA

Symbol	Parameter		SO20	Powerdip	Multiwatt15	Unit
$R_{th\ j-pins}$	Thermal Resistance Junction-pins	Max.	17	14	–	°C/W
$R_{th\ j-case}$	Thermal Resistance Junction-case	Max.	–	–	3	°C/W
$R_{th\ j-amb}$	Thermal Resistance Junction-ambient	Max.	80	80	35	°C/W

PIN CONNECTIONS (top views)

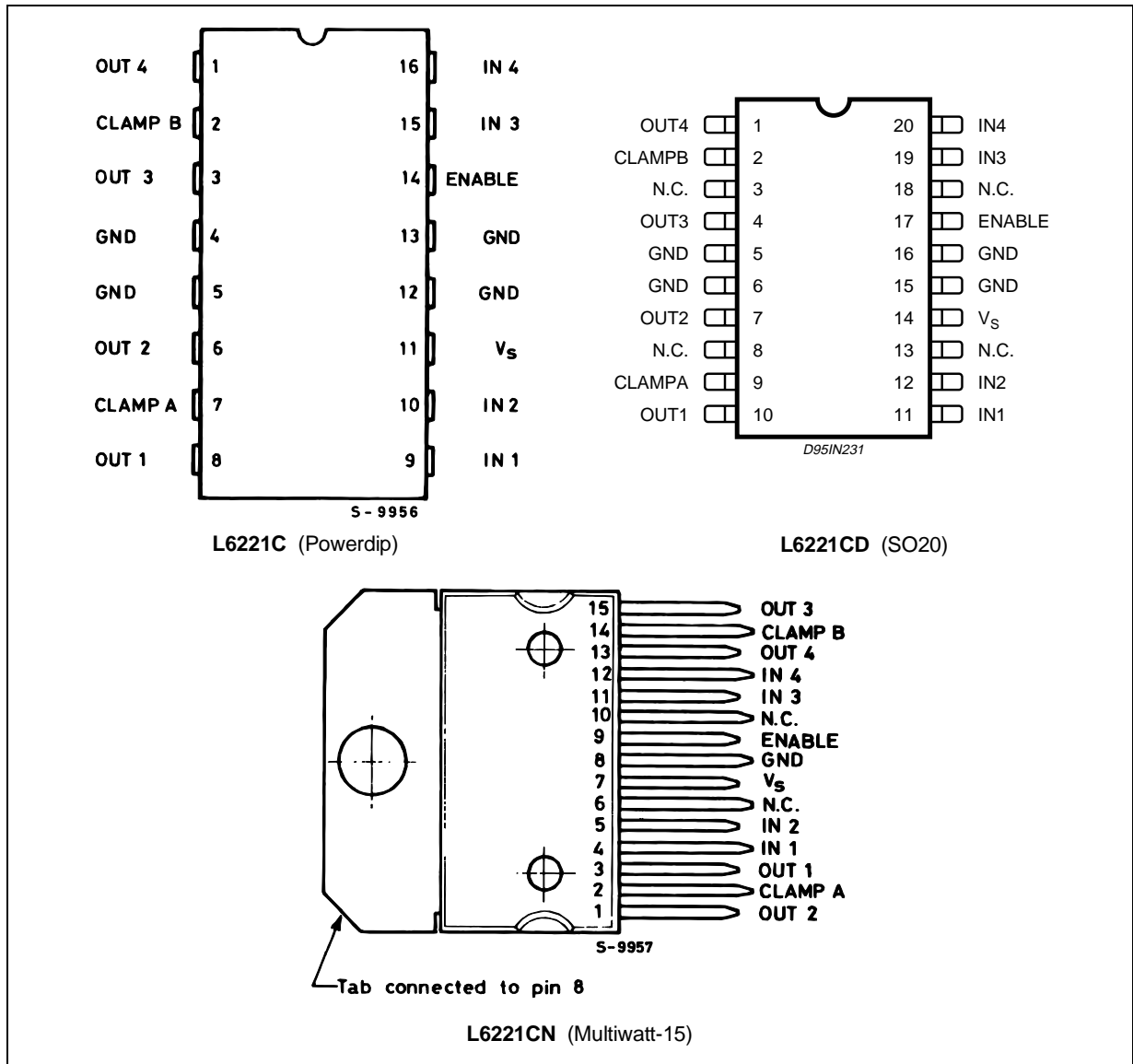

ABSOLUTE MAXIMUM RATINGS

Symbol	Parameter	Value	Unit
V _O	Output Voltage	60	V
V _S	Logic Supply Voltage	7	V
V _{IN} , V _{EN}	Input Voltage, Enable Voltage	V _S	
I _C	Continuous Collector Current (for each channel)		1.8
		for L6221CD	1.2
I _C	Collector Peak Current (repetitive, duty cycle = 10% ton = 5ms)		2.5
		for L6221CD	1.7
I _C	Collector Peak Current (non repetitive, t = 10μs)		3.2
		for L6221CD	2.2
T _{op}	Operating Temperature Range (junction)	-40 to +150	°C
T _{stg}	Storage Temperature Range	-55 to +150	°C
I _{sub}	Output Substrate Current	350	mA
P _{tot}	Total Power Dissipation	at T _{pins} = 90°C (powerdip)	4.3
		at T _{case} = 90°C (multiwatt)	20
		at T _{case} = 90°C (SO20)	3.5
		at T _{amb} = 70°C (powerdip)	1
		at T _{amb} = 70°C (multiwatt)	2.3
		at T _{amb} = 70°C (SO20)	1

TRUTH TABLE

Enable	Input	Power Out
H	H	ON
H	L	OFF
L	X	OFF

For each input : H = High level
 L = Low level
 X = Don't care

PIN FUNCTIONS (see block diagram)

Name	Function
IN 1	Input to Driver 1
IN 2	Input to Driver 2
OUT 1	Output of Driver 1
OUT 2	Output of Driver 2
CLAMP A	Diode Clamp to Driver 1 and Driver 2
IN 3	Input to Driver 3
IN 4	Input to Driver 4
OUT 3	Output of Driver 3
OUT 4	Output of Driver 4
CLAMP B	Diode Clamp to Driver3 and Driver 4
ENABLE	Enable Input to All Drivers
VS	Logic Supply Voltage
GND	Common Ground

L6221C-L6221CN-L6221CD

ELECTRICAL CHARACTERISTICS Refer to The Test Circuit to Fig.1 to Fig.9 ($V_S = 5V$, $T_{amb} = 25^\circ C$ unless otherwise specified)

Symbol	Parameter	Test Condition	Min.	Typ.	Max.	Unit
V_S	Logic Supply Voltage		4.5		5.5	V
I_S	Logic Supply Current	All outputs ON $I_C = 0.7A$ All outputs OFF			20 20	mA mA
I_{CEX}	Output Leakage Current	$V_{CE} = 60V$ $V_{EN} = V_{ENH}$ $V_{IN} = V_{INL}$			1	mA
$V_{CE(sat)}$	Collector Emitter Saturation Voltage (one input on; all others inputs off).	$V_S = 4.5V$ $V_{IN} = V_{INH}$ $V_{EN} = V_{ENH}$ $I_C = 1A$ (* $I_C = 2A$)			1.4 1.85	V V
V_{INL}, V_{ENL}	Input Low Voltage				0.8	V
I_{INL}, I_{ENL}	Input Low Current	$V_{IN} = V_{INL}$ $V_{EN} = V_{ENL}$			-100	μA
V_{INH}, V_{ENH}	Input High Voltage		2			V
I_{INH}, I_{ENH}	Input High Current	$V_{IN} = V_{INH}$ $V_{EN} = V_{ENH}$			100	μA
I_R	Clamp Diode Leakage Current	$V_R = 60V$ $V_{EN} = V_{ENH}$ $V_{IN} = V_{INL}$			100	μA
V_F	Clamp Diode Forward Voltage	$I_F = 1A$ $I_F = 2A$ (*)			1.8 2.2	V V
$t_{d(on)}$	Turn on Delay Time	$V_P = 5V$ $R_L = 10\Omega$			2	ms
$t_{d(off)}$	Turn off Delay Time	$V_P = 5V$ $R_L = 10\Omega$			5	μs
ΔI_S	Logic Supply Current Variation	$V_{IN} = 5V$ $V_{EN} = 5V$ $I_{out} = -500mA$ for Each Channel			150	mA

(*) Only for L6221C - L6221CN types

TEST CIRCUITS

(X) = Referred to Multiwatt package

X = Referred to Powerdip package

Figure 1 : Logic supply current.

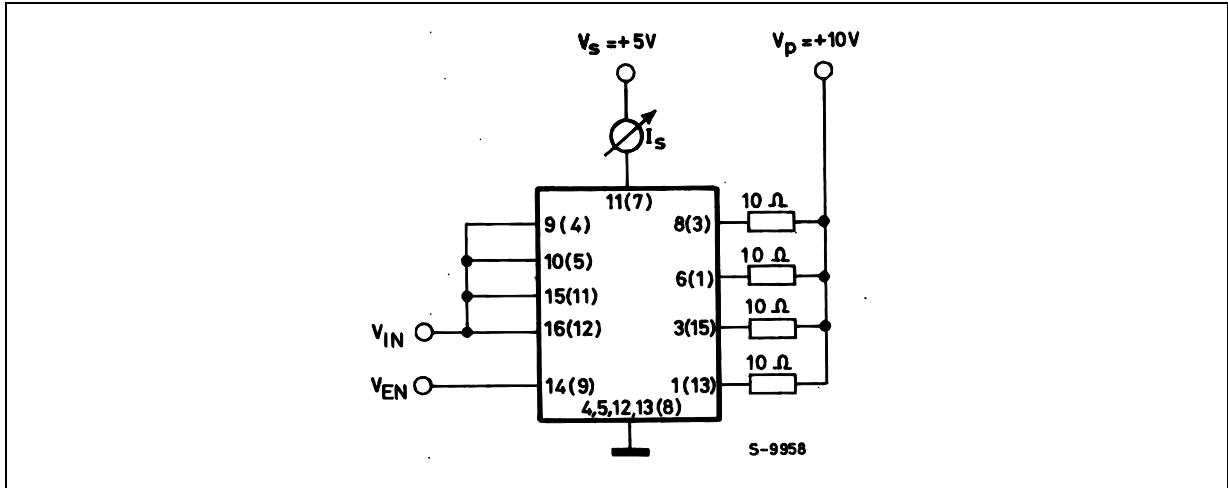

Set $V_{IN} = 4.5V$, $V_{EN} = 0.8V$, or $V_{IN} = 0.8V$, $V_{EN} = 4.5V$, for I_S (all outputs off)
 Set $V_{IN} = 2V$, $V_{EN} = 2V$, for I_S (all outputs on)

Figure 2 : Output Sustaining Voltage.

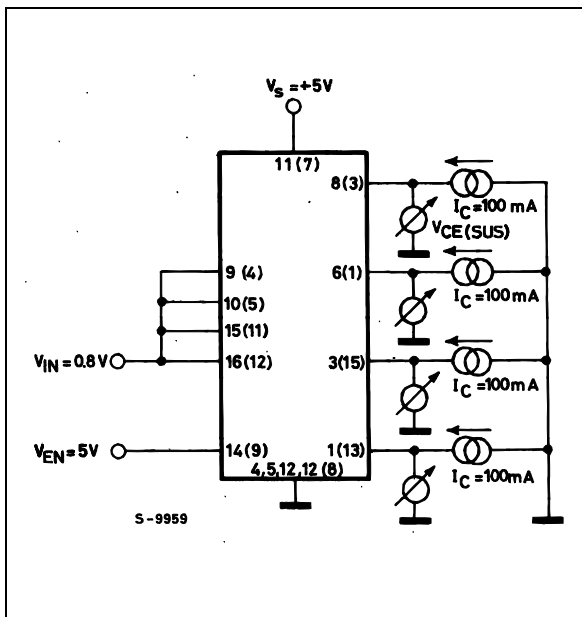
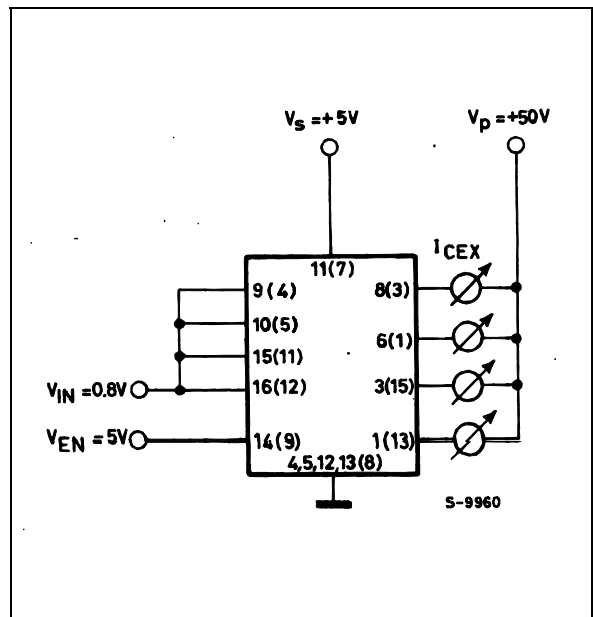

Figure 3 : Output Leakage Current.



$V_P = +60V$

Figure 4 : Collector-emitter Saturation Voltage.

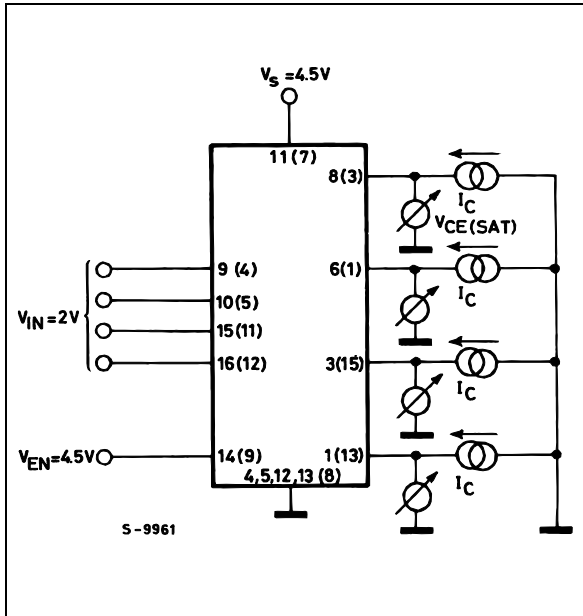
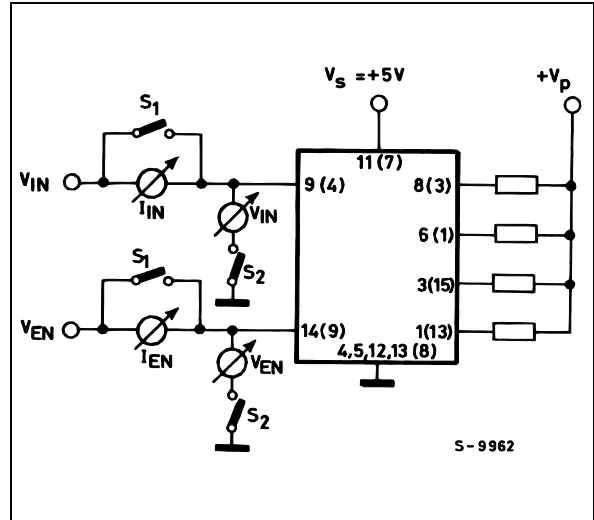
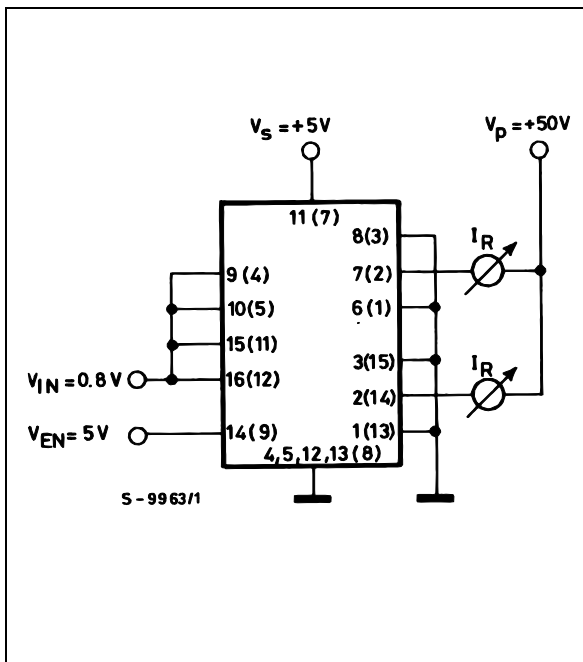

Figure 5 : Logic Input Characteristics.



Set S1, S2 open, $V_{IN}, V_{EN} = 0.8V$ for $I_{IN L}, I_{EN L}$
 Set S1, S2 open, $V_{IN}, V_{EN} = 2V$ for $I_{IN H}, I_{EN H}$
 Set S1, S2 close, $V_{IN}, V_{EN} = 0.8V$ for $V_{IN L}, V_{EN L}$
 Set S1, S2 close, $V_{IN}, V_{EN} = 2V$ for $V_{IN H}, V_{EN H}$

Figure 6 : Clamp Diode Leakage Current.



$V_p = +60V$

Figure 7 : Clamp Diode Forward Voltage.

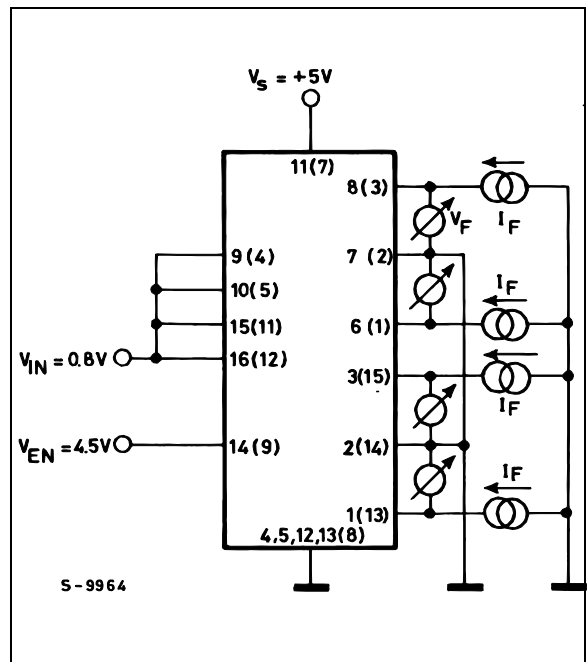

Figure 8 : Switching Times Test Circuit.

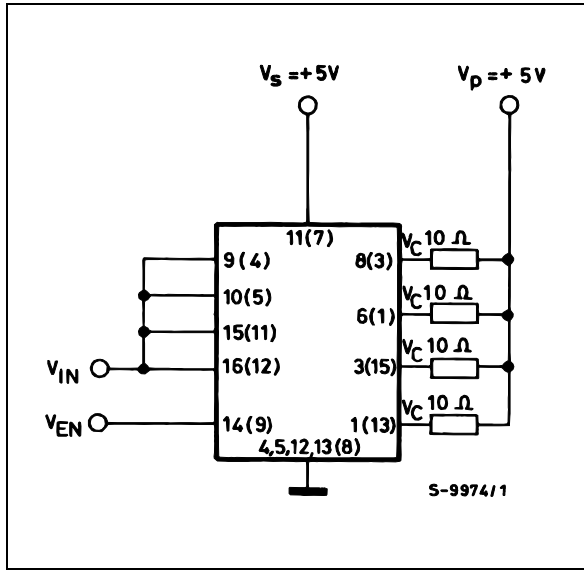

Figure 9 : Switching Times Waveforms.

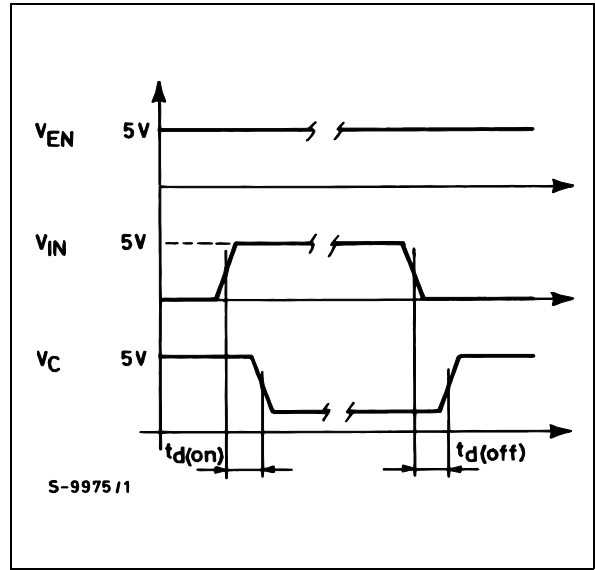

Figure 10 : Allowed Peak Collector Current vs. Duty Cycle for 1, 2, 3 or 4 Contemporary Working Outputs (L6221C).

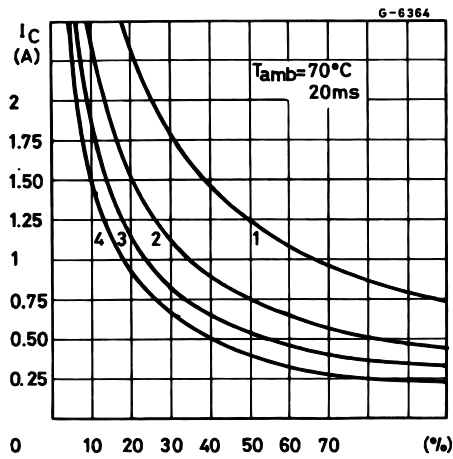

Figure 11 : Allowed Peak Collector Current vs. Duty Cycle for 1, 2, 3 or 4 Contemporary Working Outputs (L6221CN).

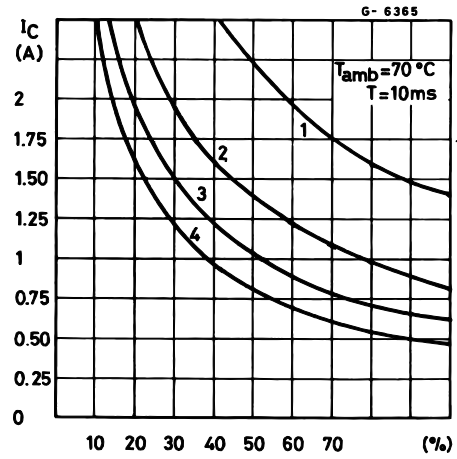

Figure 12 : Collector Saturation Voltage vs. Collector Current.

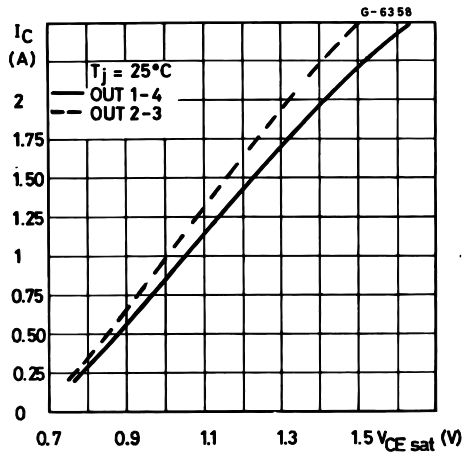

Figure 13 : Free-wheeling Diode Forward Voltage vs. Diode Current .

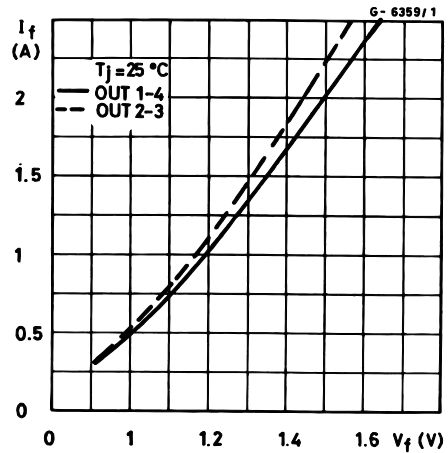

Figure 14 : Collector Saturation Voltage vs. Junction Temperature at $I_C = 1A$.

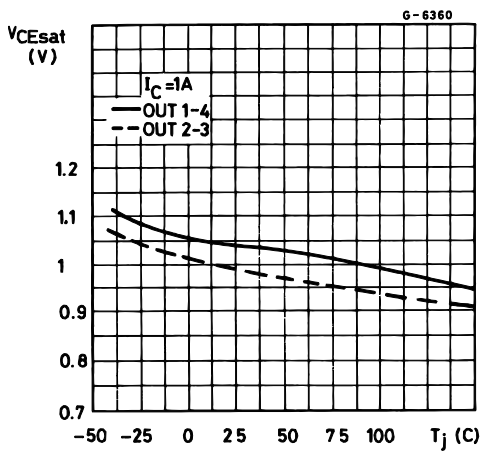

Figure 15 : Free-wheeling Diode Forward Voltage vs. Junction Temperature at $I_f = 1A$.

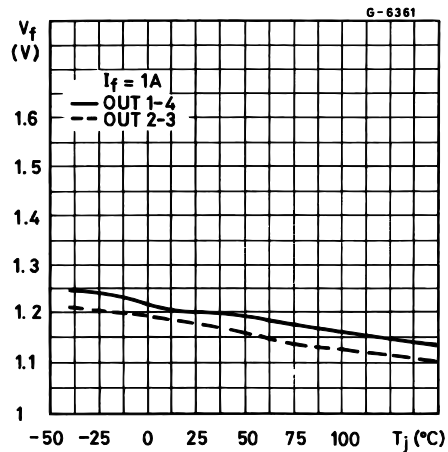

Figure 16 : Saturation Voltage vs. Junction Temperature at $I_C = 1.8A$.

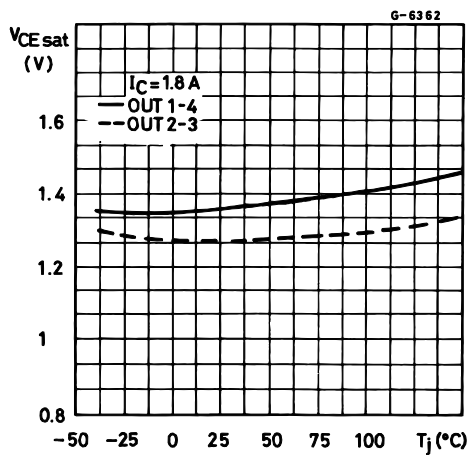

Figure 17 : Free-wheeling Diode Forward Voltage vs. Junction Temperature at $I_f = 1.8A$.

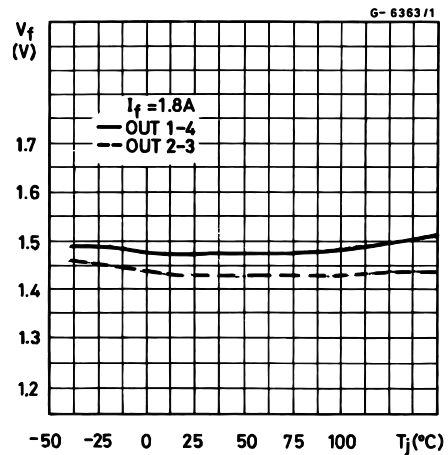
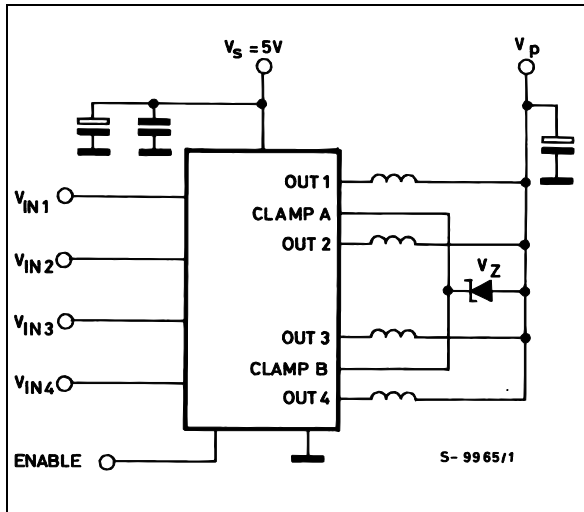

Figure 18.



APPLICATION INFORMATION

When inductive loads are driven by L6221C/CD, a zener diode in series with the integral free-wheeling diodes increases the voltage across which energy stored in the load is discharged and therefore speeds the current decay (fig. 18).

The zener has to be chosen in such a way that V_{CLAMP} is limited to 60V taking into account the zener's voltage changes due to: spread on V_z , temperature changes, and the voltage drop due to ohmic resistance.

Moreover, the instantaneous power must be limited in order to avoid the reverse second breakdown.

Figure 19 : Driver for Solenoids up to 3A.

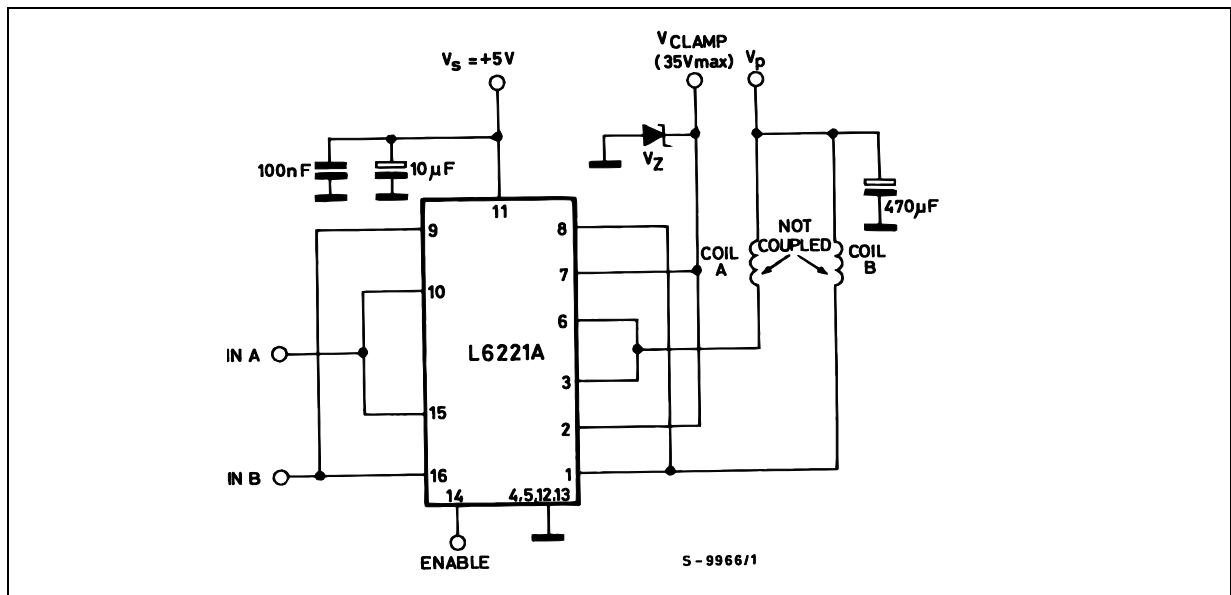

Some care must be taken to ensure that the collectors are placed close together to avoid different current partitioning at turn-off.

We suggest to put in parallel channel 1 and 4 and channel 2 and 3 as shown in figure 19 for the similar

electrical characteristics of the logic section (turn-on and turn-off delay time) and the power stages (collector saturation voltage, free-wheeling diode forward voltage).

Figure 20 : Saturation Voltage vs. Collector Current.

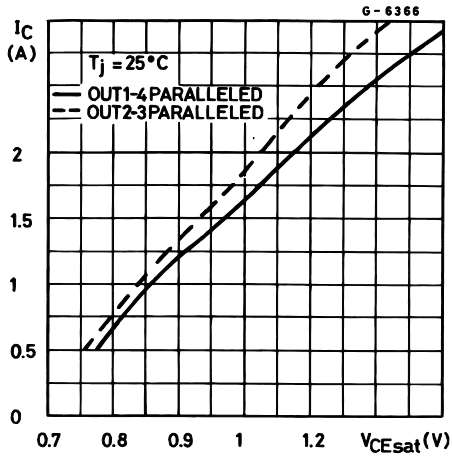

Figure 21 : Peak Collector Current vs. Duty Cycle for 1 or 2 Paralleled Outputs Driven (L6221N).

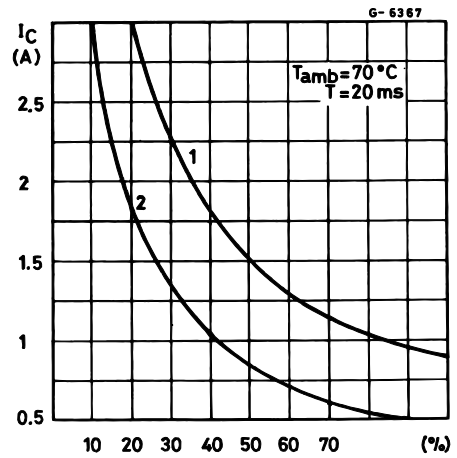
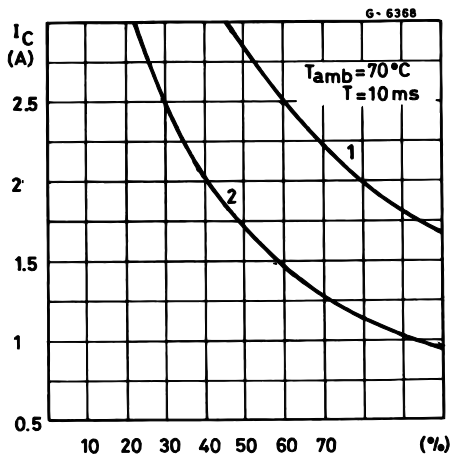

Figure 22 : Peak Collector Current vs. Duty Cycle for 1 or 2 Paralleled Outputs Driven (L6221CN).



MOUNTING INSTRUCTION

The $R_{th\ j-amb}$ of the L6221C can be reduced by soldering the GND pins to a suitable copper area of the printed circuit board (Fig. 23) or to an external heatsink (Fig. 24).

The diagram of figure 25 shows the maximum dissippable power P_{tot} and the $R_{th\ j-amb}$ as a function of the side " α " of two equal square copper areas hav-

ing a thickness of 35μ (1.4 mils). During soldering the pins temperature must not exceed $260\text{ }^{\circ}\text{C}$ and the soldering time must not be longer than 12 seconds.

The external heatsink or printed circuit copper area must be connected to electrical ground.

Figure 23 : Example of P.C. Board Copper Area Which is Used as Heatsink.

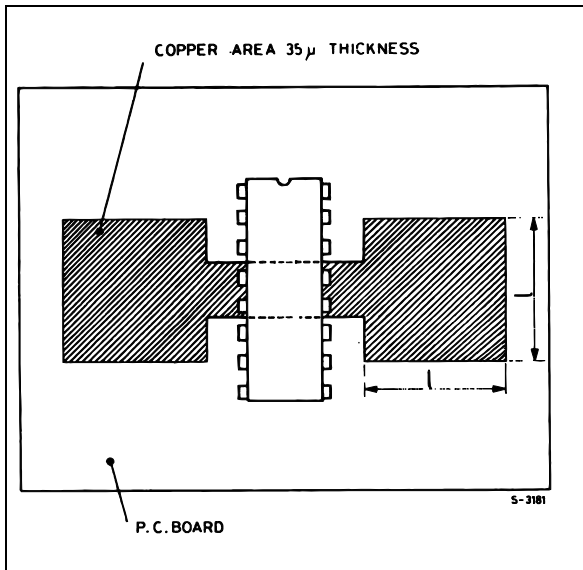

Figure 24 : External Heatsink Mounting Example.

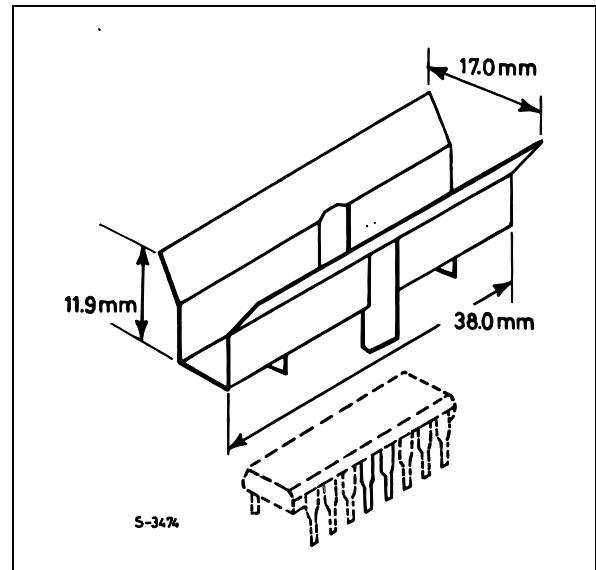

Figure 25 : Maximum Dissippable Power and Junction to Ambient Thermal Resistance vs. Side " α ".

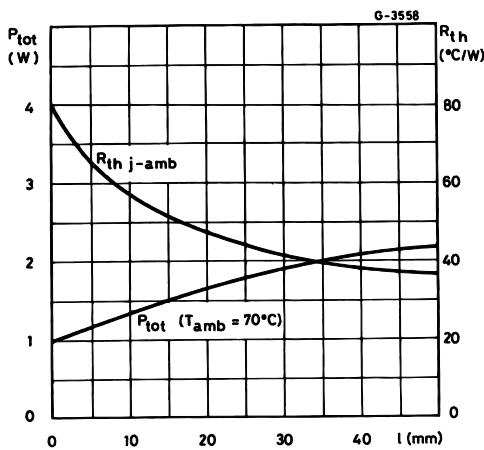
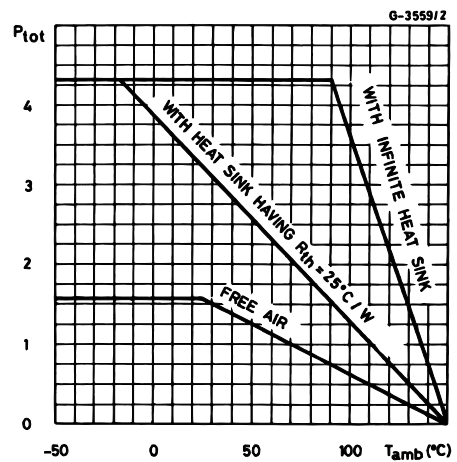
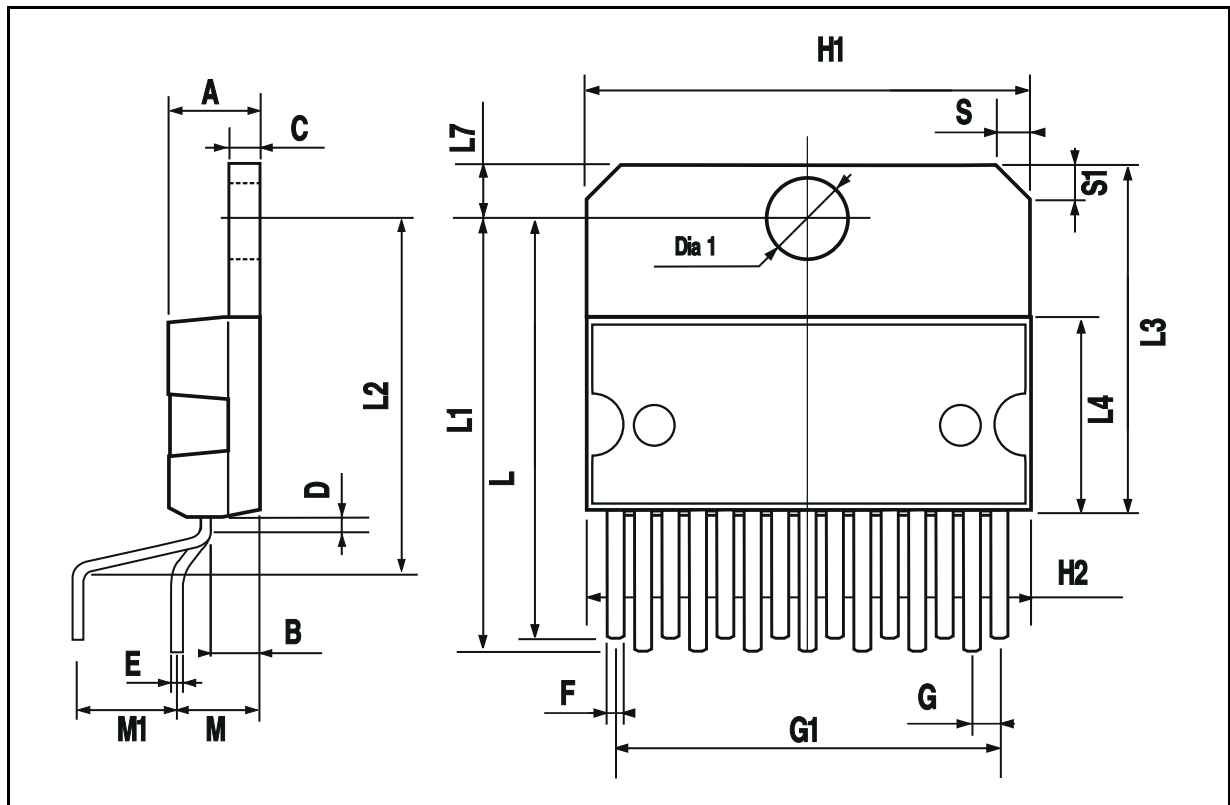

Figure 26 : Maximum Allowable Power Dissipation vs. Ambient Temperature.



MULTIWATT15 PACKAGE MECHANICAL DATA

DIM.	mm			inch		
	MIN.	TYP.	MAX.	MIN.	TYP.	MAX.
A			5			0.197
B			2.65			0.104
C			1.6			0.063
D		1			0.039	
E	0.49		0.55	0.019		0.022
F	0.66		0.75	0.026		0.030
G	1.14	1.27	1.4	0.045	0.050	0.055
G1	17.57	17.78	17.91	0.692	0.700	0.705
H1	19.6			0.772		
H2			20.2			0.795
L	22.1		22.6	0.870		0.890
L1	22		22.5	0.866		0.886
L2	17.65		18.1	0.695		0.713
L3	17.25	17.5	17.75	0.679	0.689	0.699
L4	10.3	10.7	10.9	0.406	0.421	0.429
L7	2.65		2.9	0.104		0.114
M	4.2	4.3	4.6	0.165	0.169	0.181
M1	4.5	5.08	5.3	0.177	0.200	0.209
S	1.9		2.6	0.075		0.102
S1	1.9		2.6	0.075		0.102
Dia1	3.65		3.85	0.144		0.152



POWERDIP16 PACKAGE MECHANICAL DATA

DIM.	mm			inch		
	MIN.	TYP.	MAX.	MIN.	TYP.	MAX.
a1	0.51			0.020		
B	0.85		1.40	0.033		0.055
b		0.50			0.020	
b1	0.38		0.50	0.015		0.020
D			20.0			0.787
E		8.80			0.346	
e		2.54			0.100	
e3		17.78			0.700	
F			7.10			0.280
I			5.10			0.201
L		3.30			0.130	
Z			1.27			0.050

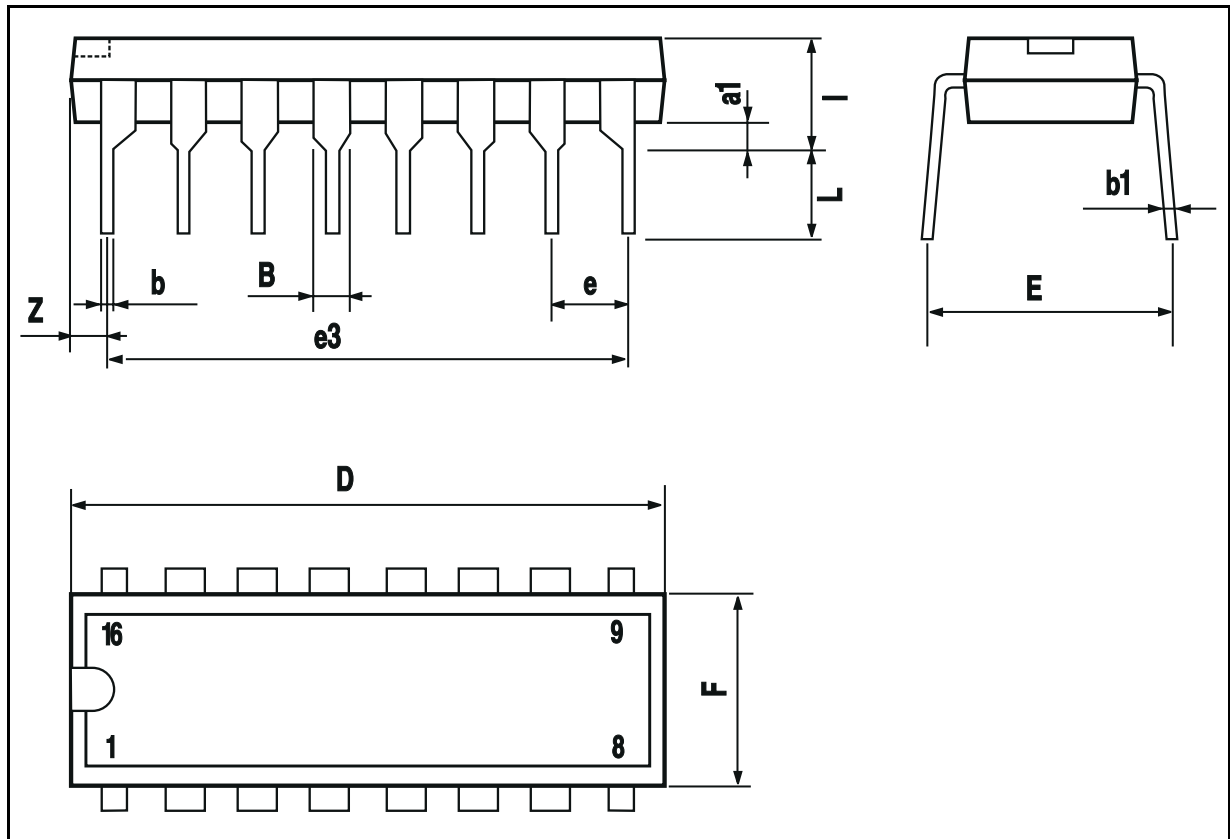

SO20 PACKAGE MECHANICAL DATA

DIM.	mm			inch		
	MIN.	TYP.	MAX.	MIN.	TYP.	MAX.
A			2.65			0.104
a1	0.1		0.3	0.004		0.012
a2			2.45			0.096
b	0.35		0.49	0.014		0.019
b1	0.23		0.32	0.009		0.013
C		0.5			0.020	
c1	45 (typ.)					
D	12.6		13.0	0.496		0.512
E	10		10.65	0.394		0.419
e		1.27			0.050	
e3		11.43			0.450	
F	7.4		7.6	0.291		0.299
L	0.5		1.27	0.020		0.050
M			0.75			0.030
S	8 (max.)					

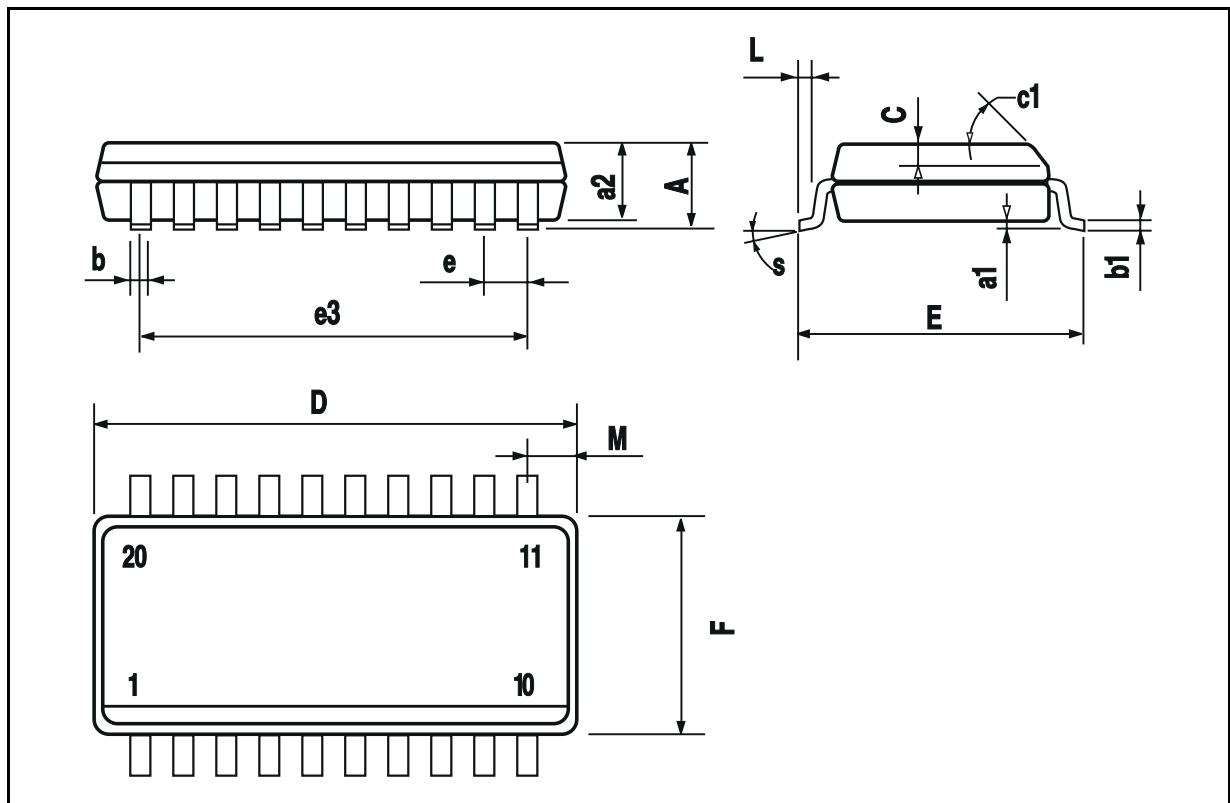

Information furnished is believed to be accurate and reliable. However, SGS-THOMSON Microelectronics assumes no responsibility for the consequences of use of such information nor for any infringement of patents or other rights of third parties which may result from its use. No license is granted by implication or otherwise under any patent or patent rights of SGS-THOMSON Microelectronics. Specification mentioned in this publication are subject to change without notice. This publication supersedes and replaces all information previously supplied. SGS-THOMSON Microelectronics products are not authorized for use as critical components in life support devices or systems without express written approval of SGS-THOMSON Microelectronics.

© 1997 SGS-THOMSON Microelectronics – Printed in Italy – All Rights Reserved

SGS-THOMSON Microelectronics GROUP OF COMPANIES

Australia - Brazil - Canada - China - France - Germany - Hong Kong - Italy - Japan - Korea - Malaysia - Malta - Morocco -
The Netherlands - Singapore - Spain - Sweden - Switzerland - Taiwan - Thailand - United Kingdom - U.S.A.