



# L6910

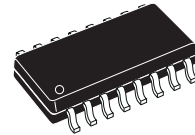
## ADJUSTABLE STEP DOWN CONTROLLER WITH SYNCHRONOUS RECTIFICATION

### FEATURE

- OPERATING SUPPLY VOLTAGE FROM 5V TO 12V BUSES
- UP TO 1.3A GATE CURRENT CAPABILITY
- ADJUSTABLE OUTPUT VOLTAGE
- N-INVERTING E/A INPUT AVAILABLE
- $0.9V \pm 1.5\%$  VOLTAGE REFERENCE
- VOLTAGE MODE PWM CONTROL
- VERY FAST LOAD TRANSIENT RESPONSE
- 0% TO 100% DUTY CYCLE
- POWER GOOD OUTPUT
- OVERVOLTAGE PROTECTION
- HICCUP OVERCURRENT PROTECTION
- 200kHz INTERNAL OSCILLATOR
- OSCILLATOR EXTERNALLY ADJUSTABLE FROM 50kHz TO 1MHz
- SOFT START AND INHIBIT
- PACKAGE: SO-16

### APPLICATIONS

- SUPPLY FOR MEMORIES AND TERMINATIONS
- COMPUTER ADD-ON CARDS
- LOW VOLTAGE DISTRIBUTED DC-DC
- MAG-AMP REPLACEMENT



SO-16 (Narrow)  
ORDERING NUMBERS: L6910  
L6910TR (Tape & Reel)

### DESCRIPTION

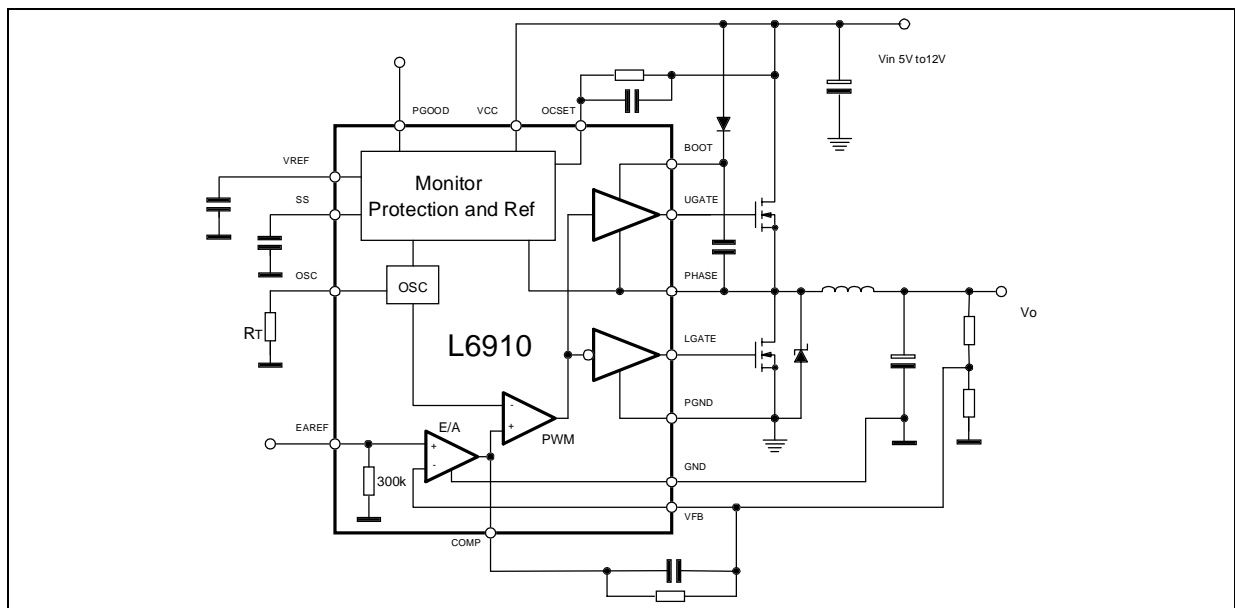
The device is a pwm controller for high performance dc-dc conversion from 3.3V, 5V and 12V buses.

The output voltage is adjustable down to 0.9V; higher voltages can be obtained with an external voltage divider.

High peak current gate drivers provide for fast switching to the external power section, and the output current can be in excess of 20A.

The device assures protections against load overcurrent and overvoltage. An internal crowbar is also provided turning on the low side mosfet as long as the over-voltage is detected. In case of over-current detection, the soft start capacitor is discharged and the system works in HICCUP mode.

### BLOCK DIAGRAM



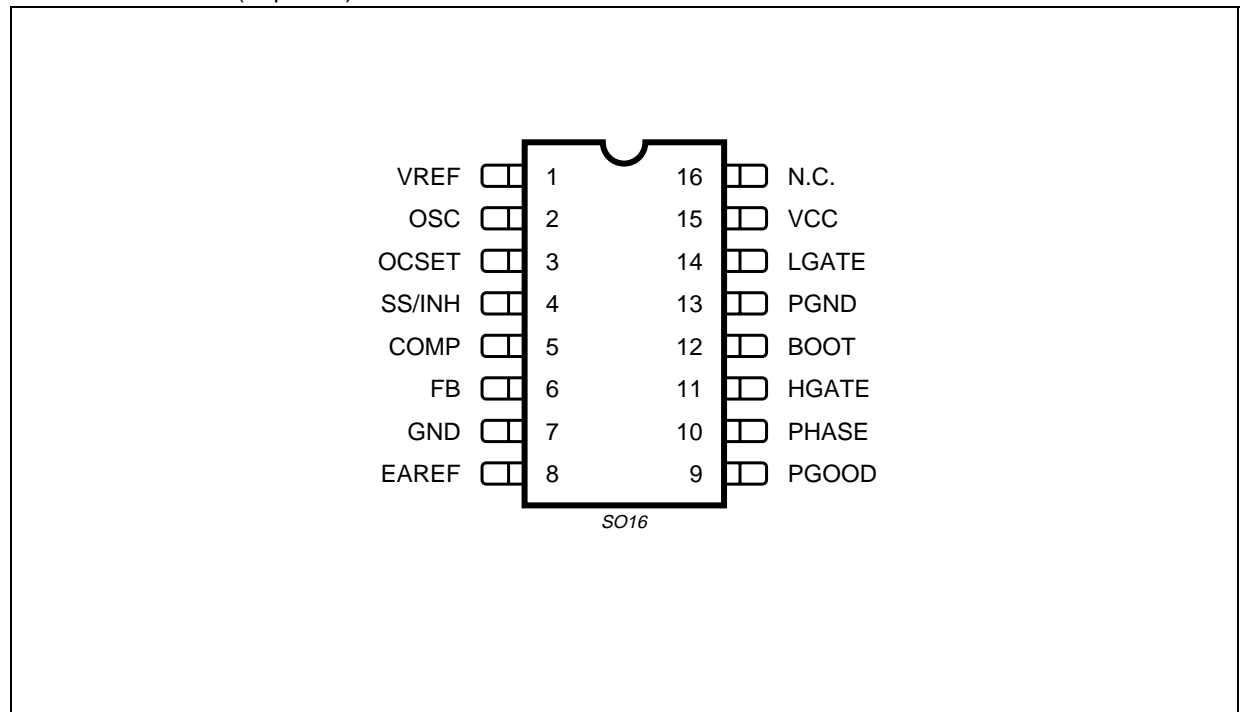
**ABSOLUTE MAXIMUM RATINGS**

Symbol	Parameter	Value	Unit
V <sub>cc</sub>	V <sub>cc</sub> to GND, PGND	15	V
V <sub>BOOT</sub> V <sub>PHASE</sub>	Boot Voltage	15	V
V <sub>HGATE</sub> - V <sub>PHASE</sub>		15	V
	OCSET, LGATE, PHASE	-0.3 to V <sub>cc</sub> +0.3	V
	SS, FB, PGOOD, VREF, EAREF, RT	7	V
	COMP	6.5	V
T <sub>j</sub>	Junction Temperature Range	-40 to 150	°C
T <sub>stg</sub>	Storage temperature range	-40 to 150	°C
P <sub>tot</sub>	Maximum power dissipation at T <sub>amb</sub> = 25°C	1	W

**THERMAL DATA**

Symbol	Parameter	Value	Unit
R <sub>th j-amb</sub>	Thermal Resistance Junction to Ambient	120	°C/W

**PIN CONNECTION (Top view)**



## PIN FUNCTION

N	Name	Description
1	VREF	Internal 0.9V $\pm$ 1.5% reference is available for external regulators or for the internal error amplifier (connecting this pin to EAREF) if external reference is not available. A minimum 1nF capacitor is required. If the pin is forced to a voltage lower than 70%, the device enters the hiccup mode.
2	OSC	Oscillator switching frequency pin. Connecting an external resistor ( $R_T$ ) from this pin to GND, the external frequency is increased according to the equation: $f_{OSC,RT} = 200KHz + \frac{4.94 \cdot 10^6}{R_T(K\Omega)}$ Connecting a resistor ( $R_T$ ) from this pin to Vcc (12V), the switching frequency is reduced according to the equation: $f_{OSC,RT} = 200KHz - \frac{4.306 \cdot 10^7}{R_T(K\Omega)}$ If the pin is not connected, the switching frequency is 200KHz. The voltage at this pin is fixed at 1.23V. Forcing a 50 $\mu$ A current into this pin, the built in oscillator stops to switch. In Over Voltage condition this pin goes over 3V until that condition is removed.
3	OCSET	A resistor connected from this pin and the upper Mos Drain sets the current limit protection. The internal 200 $\mu$ A current generator sinks a constant current through the external resistor. The Over-Current threshold is due to the following equation: $I_P = \frac{I_{OCSET} \cdot R_{OCSET}}{R_{DSon}}$
4	SS/INH	The soft start time is programmed connecting an external capacitor from this pin and GND. The internal current generator forces through the capacitor 10 $\mu$ A. This pin can be used to disable the device forcing a voltage lower than 0.4V
5	COMP	This pin is connected to the error amplifier output and is used to compensate the voltage control feedback loop.
6	FB	This pin is connected to the error amplifier inverting input and is used to compensate the voltage control feedback loop. Connected to the output resistor divider, if used, or directly to Vout, it manages also over-voltage conditions and the PGOOD signal
7	GND	All the internal references are referred to this pin. Connect it to the PCB signal ground.
8	EAREF	Error amplifier non-inverting input. Connect to this pin an external reference (from 0.9V to 3V) for the PWM regulation or short it to VREF pin to use the internal reference. If this pin goes under 650mV (typ), the device shuts down.
9	PGOOD	This pin is an open collector output and it is pulled low if the output voltage is not within the above specified thresholds. If not used it may be left floating.
10	PHASE	This pin is connected to the source of the upper mosfet and provides the return path for the high side driver. This pin monitors the drop across the upper mosfet for the current limit together with OCSET.
11	HGATE	High side gate driver output.
12	BOOT	Bootstrap capacitor pin. Through this pin is supplied the high side driver and the upper mosfet. Connect through a capacitor to the PHASE pin and through a diode to Vcc (cathode vs. boot).
13	PGND	Power ground pin. This pin has to be connected closely to the low side mosfet source in order to reduce the noise injection into the device
14	LGATE	This pin is the lower mosfet gate driver output
15	VCC	Device supply voltage. The operative supply voltage ranges is from 5V to 12V. DO NOT CONNECT $V_{IN}$ TO A VOLTAGE GREATER THAN $V_{CC}$ .
16	N.C.	This pin is not internally bonded. It may be left floating or connected to GND.

**ELECTRICAL CHARACTERISTICS** ( $V_{CC} = 12V$ ,  $T_J = 25^\circ C$  unless otherwise specified)

Symbol	Parameter	Test Condition	Min	Typ	Max	Unit
<b>V<sub>CC</sub> SUPPLY CURRENT</b>						
I <sub>CC</sub>	V <sub>CC</sub> Supply current	OSC = open; SS to GND	4	7	9	mA
<b>POWER-ON</b>						
	Turn-On V <sub>CC</sub> threshold	VOCSET = 4V	4.0	4.3	4.6	V
	Turn-Off V <sub>CC</sub> threshold	VOCSET = 4V	3.8	4.1	4.4	V
	Rising VOCSET threshold			1.24	1.4	V
	Turn On EAREF threshold	VOCSET = 4V		650	750	mV
<b>SOFT START AND INHIBIT</b>						
I <sub>SS</sub>	Soft start Current S.S. current in INH condition	SS = 2V SS = 0 to 0.4V	6	10 35	14 60	μA μA
<b>OSCILLATOR</b>						
f <sub>OSC</sub>	Initial Accuracy	OSC = OPEN OSC = OPEN; T <sub>j</sub> = 0° to 125°	180 170	200	220 230	KHz kHz
f <sub>OSC,RT</sub>	Total Accuracy	16 KΩ < R <sub>T</sub> to GND < 200 KΩ	-15		15	%
ΔV <sub>osc</sub>	Ramp amplitude			1.9		V
<b>REFERENCE</b>						
V <sub>REF</sub>	Reference Voltage	C <sub>REF</sub> = 1nF; I <sub>REF</sub> = 0 to 100μA	0.886	0.900	0.913	V
V <sub>OUT</sub>	Output Voltage Accuracy	V <sub>OUT</sub> = V <sub>FB</sub> ; V <sub>EAREF</sub> = V <sub>REF</sub>	0.886	0.900	0.913	V
V <sub>REF</sub>	Reference Voltage	C <sub>REF</sub> = 1nF; T <sub>J</sub> = 0 to 125°C	-2		+2	%
<b>ERROR AMPLIFIER</b>						
I <sub>EAREF</sub>	N.I. bias current	V <sub>EAREF</sub> = 3V		10		μA
	EAREF Input Resistance	Vs. GND		300		kΩ
I <sub>FB</sub>	I.I. bias current	V <sub>FB</sub> = 0V to 3V		0.01	0.5	μA
V <sub>CM</sub>	Common Mode Voltage		0.8		3	V
V <sub>COMP</sub>	Output Voltage		0.5		4	V
G <sub>V</sub>	Open Loop Voltage Gain		70	85		dB
GBWP	Gain-Bandwidth Product			10		MHz
SR	Slew-Rate	COMP = 10pF		10		V/μs
<b>GATE DRIVERS</b>						
I <sub>HGATE</sub>	High Side Source Current	V <sub>BOOT</sub> - V <sub>PHASE</sub> = 12V V <sub>HGATE</sub> - V <sub>PHASE</sub> = 6V	1	1.3		A
R <sub>HGATE</sub>	High Side Sink Resistance	V <sub>BOOT</sub> - V <sub>PHASE</sub> = 12V		2	4	Ω
I <sub>LGATE</sub>	Low Side Source Current	V <sub>CC</sub> = 12V; V <sub>LGATE</sub> = 6V	0.9	1.1		A
R <sub>LGATE</sub>	Low Side Sink Resistance	V <sub>CC</sub> = 12V		1.5	3	Ω
	Output Driver Dead Time	PHASE connected to GND	90		210	ns
<b>PROTECTIONS</b>						
I <sub>OCSET</sub>	OCSET Current Source	VOCSET = 4V	170	200	230	μA
	Over Voltage Trip (V <sub>FB</sub> / V <sub>EAREF</sub> )	V <sub>FB</sub> Rising		117	120	%
I <sub>OSC</sub>	OSC Sourcing Current	V <sub>FB</sub> > OVP Trip	15	30		mA
<b>POWER GOOD</b>						
	Upper Threshold (V <sub>FB</sub> / V <sub>EAREF</sub> )	V <sub>FB</sub> Rising	108	110	112	%
	Lower Threshold (V <sub>FB</sub> / V <sub>EAREF</sub> )	V <sub>FB</sub> Falling	88	90	92	%
	Hysteresis (V <sub>FB</sub> / V <sub>EAREF</sub> )	Upper and Lower threshold		2		%
V <sub>PGOOD</sub>	PGOOD Voltage Low	I <sub>PGOOD</sub> = -5mA		0.5		V

## Device Description

The device is an integrated circuit realized in BCD technology. The controller provides complete control logic and protection for a high performance step-down DC-DC converter. It is designed to drive N Channel Mosfets in a synchronous-rectified buck topology. The output voltage of the converter can be precisely regulated down to 900mV with a maximum tolerance of  $\pm 1.5\%$  when the internal reference is used (simply connecting together EAREF and VREF pins). The device allows also using an external reference (0.9V to 3V) for the regulation. The device provides voltage-mode control with fast transient response. It includes a 200kHz free-running oscillator that is adjustable from 50kHz to 1MHz. The error amplifier features a 10MHz gain-bandwidth product and 10V/ $\mu$ s slew rate that permits to realize high converter bandwidth for fast transient performance. The PWM duty cycle can range from 0% to 100%. The device protects against over-current conditions entering in HICCUP mode. The device monitors the current by using the  $r_{DS(ON)}$  of the upper MOSFET(s) that eliminates the need for a current sensing resistor. The device is available in SO16 narrow package.

## Oscillator

The switching frequency is internally fixed to 200kHz. The internal oscillator generates the triangular waveform for the PWM charging and discharging with a constant current an internal capacitor. The current delivered to the oscillator is typically 50 $\mu$ A ( $F_{sw} = 200\text{kHz}$ ) and may be varied using an external resistor ( $R_T$ ) connected between OSC pin and GND or  $V_{CC}$ . Since the OSC pin is maintained at fixed voltage (typ. 1.235V), the frequency is varied proportionally to the current sunk (forced) from (into) the pin.

In particular connecting  $R_T$  vs. GND the frequency is increased (current is sunk from the pin), according to the following relationship:

$$f_{OSC,RT} = 200\text{kHz} + \frac{4.94 \cdot 10^6}{R_T(\text{K}\Omega)}$$

Connecting  $R_T$  to  $V_{CC} = 12\text{V}$  or to  $V_{CC} = 5\text{V}$  the frequency is reduced (current is forced into the pin), according to the following relationships:

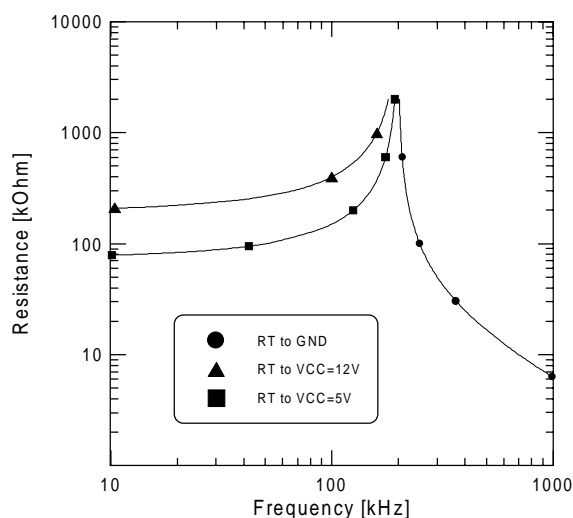
$$f_{OSC,RT} = 200\text{kHz} - \frac{4.306 \cdot 10^7}{R_T(\text{K}\Omega)} \quad V_{CC} = 12\text{V}$$

$$f_{OSC,RT} = 200\text{kHz} - \frac{15 \cdot 10^6}{R_T(\text{K}\Omega)} \quad V_{CC} = 5\text{V}$$

Switching frequency variation vs.  $R_T$  are repeated in Fig. 1.

Note that forcing a 50 $\mu$ A current into this pin, the device stops switching because no current is delivered to the oscillator.

**Figure 1.**



## Reference

A precise  $\pm 1.5\%$  0.9V reference is available. This reference must be filtered with 1nF ceramic capacitor to avoid instability in the internal linear regulator. It is able to deliver up to 100 $\mu$ A and may be used as reference for the device regulation and also for other devices. If forced under 70% of its nominal value, the device enters in Hiccup mode until this condition is removed.

Through the EAREF pin the reference for the regulation is taken. This pin directly connects the non-inverting input of the error amplifier. An external reference (or the internal 0.9V  $\pm 1.5\%$ ) may be used. The input for this pin can range from 0.9V to 3V. It has an internal pull-down (300k $\Omega$  resistor) that forces the device shutdown if no reference is connected (pin floating). However the device is shut down if the voltage on the EAREF pin is lower than 650mV (typ).

**Soft Start**

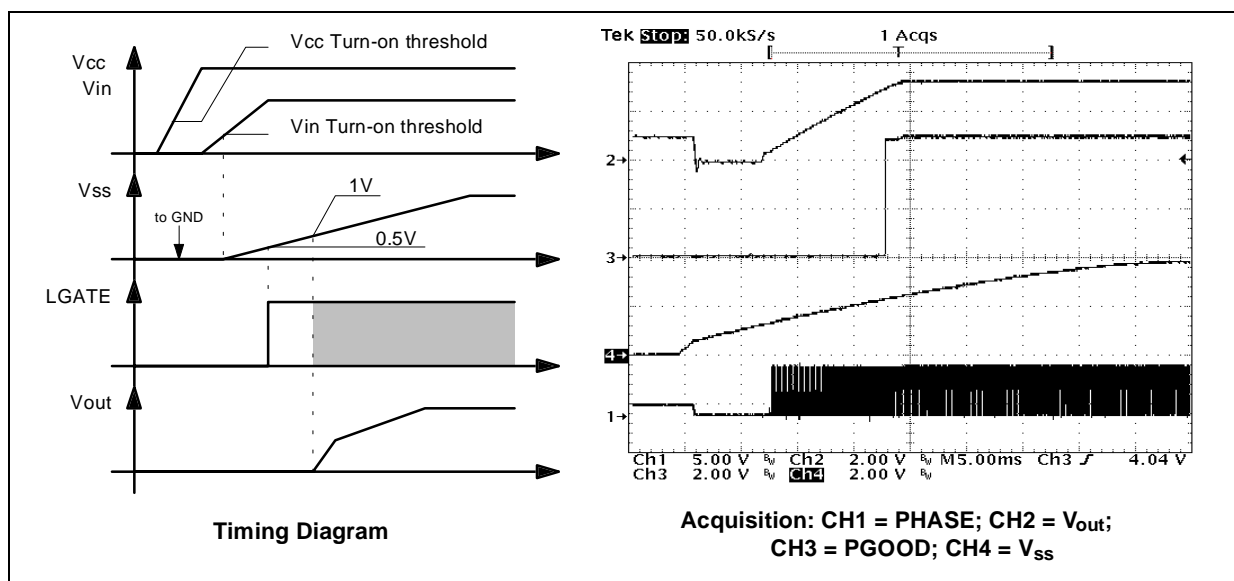
At start-up a ramp is generated charging the external capacitor  $C_{SS}$  with an internal current generator. The initial value for this current is of  $35\mu A$  and speeds-up the charge of the capacitor up to 0.5V. After that it becomes  $10\mu A$  until the final charge value of approximately 4V.

When the voltage across the soft start capacitor ( $V_{SS}$ ) reaches 0.5V the lower power MOS is turned on to discharge the output capacitor. As  $V_{SS}$  reaches 1.1V (i.e. the oscillator triangular wave inferior limit) also the upper MOS begins to switch and the output voltage starts to increase.

No switching activity is observable if SS is kept lower than 0.5V and both mosfets are off.

If VCC and OCSET pins are not above their own turn-on thresholds and  $V_{EAREF}$  is not above 650mV, the Soft-Start will not take place, and the relative pin is internally shorted to GND. During normal operation, if any under-voltage is detected on one of the two supplies, the SS pin is internally shorted to GND and so the SS capacitor is rapidly discharged.

**Figure 2. Soft Start (with Reference Present)**



**Driver Section**

The driver capability on the high and low side drivers allows using different types of power MOS (also multiple MOS to reduce the  $R_{DS(on)}$ ), maintaining fast switching transition.

The low-side mos driver is supplied directly by Vcc while the high-side driver is supplied by the BOOT pin.

Adaptative dead time control is implemented to prevent cross-conduction and allow to use several kinds of mosfets. The upper mos turn-on is avoided if the lower gate is over about 200mV while the lower mos turn-on is avoided if the PHASE pin is over about 500mV. The lower mos is in any case turned-on after 200ns from the high side turn-off.

The peak current is shown for both the upper (fig. 3) and the lower (fig. 4) driver at 5V and 12V. A 3.3nF capacitive load has been used in these measurements.

For the lower driver, the source peak current is 1.1A @  $V_{CC} = 12V$  and 500mA @  $V_{CC} = 5V$ , and the sink peak current is 1.3A @  $V_{CC} = 12V$  and 500mA @  $V_{CC} = 5V$ .

Similarly, for the upper driver, the source peak current is 1.3A @  $V_{boot-V_{phase}} = 12V$  and 600mA @  $V_{boot-V_{phase}} = 5V$ , and the sink peak current is 1.3A @  $V_{boot-V_{phase}} = 12V$  and 550mA @  $V_{boot-V_{phase}} = 5V$ .

Figure 3. High Side driver peak current.  $V_{boot}-V_{phase} = 12V$  (right)  $V_{boot}-V_{phase} = 5V$  (left)

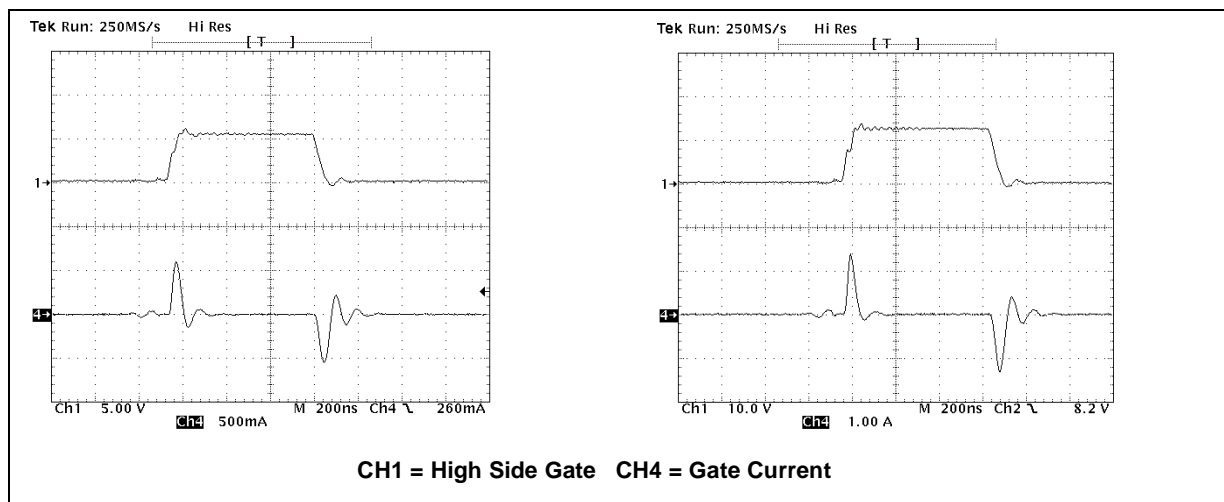
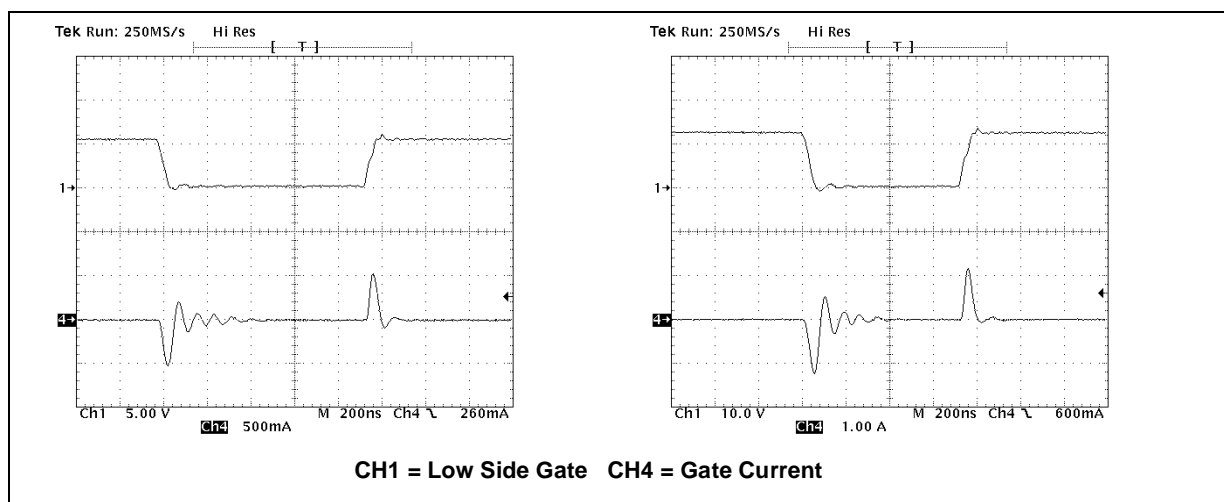


Figure 4. Low Side driver peak current.  $V_{CC} = 12V$  (right)  $V_{CC} = 5V$  (left)



### Monitoring and Protections

The output voltage is monitored by means of pin FB. If it is not within  $\pm 10\%$  (typ.) of the programmed value, the powergood output is forced low.

The device provides overvoltage protection, when the voltage sensed on pin FB reaches a value 17% (typ.) greater than the reference the OSC pin is forced high (3V typ.) and the lower driver is turned on as long as the over-voltage is detected.

Overcurrent protection is performed by the device comparing the drop across the high side MOS, due to the  $R_{DS(on)}$ , with the voltage across the external resistor ( $R_{OCS}$ ) connected between the OCSET pin and drain of the upper MOS. Thus the overcurrent threshold ( $I_P$ ) can be calculated with the following relationship:

$$I_P = \frac{R_{OCS} \cdot I_{OCS}}{R_{dsON}}$$

Where the typical value of  $I_{OCS}$  is  $200\mu A$ . To calculate the  $R_{OCS}$  value it must be considered the maximum  $R_{dsON}$  (also the variation with temperature) and the minimum value of  $I_{OCS}$ . To avoid undesirable trigger of overcurrent protection this relationship must be satisfied:

$$I_P \geq I_{OUTMAX} + \frac{\Delta I}{2} = I_{PEAK}$$

Where  $\Delta I$  is the inductance ripple current and  $I_{OUTMAX}$  is the maximum output current.

In case of over current detection the soft start capacitor is discharged with constant current (10 $\mu$ A typ.) and when the SS pin reaches 0.5V the soft start phase is restarted. During the soft start the over-current protection is always active and if such kind of event occurs, the device turns off both mosfets, and the SS capacitor is discharged again (after reaching the upper threshold of about 4V). The system is now working in HICCUP mode, as shown in figure 5. After removing the cause of the over-current, the device restart working normally without power supplies turn off and on.

Figure 5. Hiccup Mode

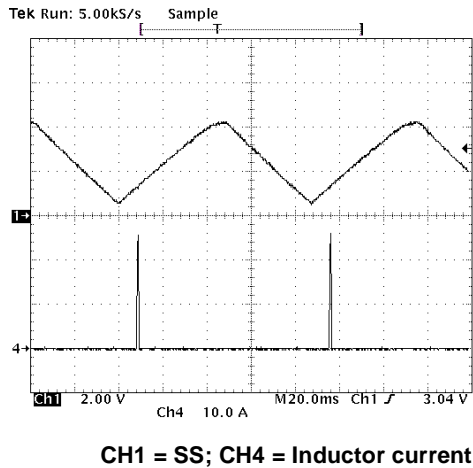
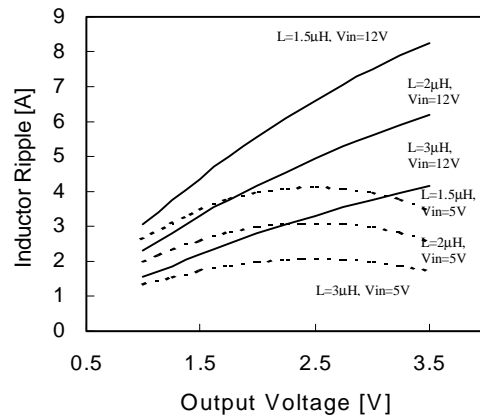


Figure 6. Inductor ripple current vs. Vout



**Inductor design**

The inductance value is defined by a compromise between the transient response time, the efficiency, the cost and the size. The inductor has to be calculated to sustain the output and the input voltage variation to maintain the ripple current  $\Delta I_L$  between 20% and 30% of the maximum output current. The inductance value can be calculated with this relationship:

$$L = \frac{V_{IN} - V_{OUT}}{f_{sw} \cdot \Delta I_L} \cdot \frac{V_{OUT}}{V_{IN}}$$

Where  $f_{sw}$  is the switching frequency,  $V_{IN}$  is the input voltage and  $V_{OUT}$  is the output voltage. Figure 6 shows the ripple current vs. the output voltage for different values of the inductor, with  $V_{IN} = 5V$  and  $V_{IN} = 12V$ .

Increasing the value of the inductance reduces the ripple current but, at the same time, reduces the converter response time to a load transient. If the compensation network is well designed, the device is able to open or close the duty cycle up to 100% or down to 0%. The response time is now the time required by the inductor to change its current from initial to final value. Since the inductor has not finished its charging time, the output current is supplied by the output capacitors. Minimizing the response time can minimize the output capacitance required.

The response time to a load transient is different for the application or the removal of the load: if during the application of the load the inductor is charged by a voltage equal to the difference between the input and the output voltage, during the removal it is discharged only by the output voltage. The following expressions give approximate response time for  $\Delta I$  load transient in case of enough fast compensation network response:

$$t_{application} = \frac{L \cdot \Delta I}{V_{IN} - V_{OUT}} \quad t_{removal} = \frac{L \cdot \Delta I}{V_{OUT}}$$

The worst condition depends on the input voltage available and the output voltage selected. Anyway the worst case is the response time after removal of the load with the minimum output voltage programmed and the maximum input voltage available.

### Output Capacitor

The output capacitor is a basic component for the fast response of the power supply. In fact, during load transient, for first few microseconds they supply the current to the load. The controller recognizes immediately the load transient and sets the duty cycle at 100%, but the current slope is limited by the inductor value. The output voltage has a first drop due to the current variation inside the capacitor (neglecting the effect of the ESL):

$$\Delta V_{OUT} = \Delta I_{OUT} \cdot ESR$$

A minimum capacitor value is required to sustain the current during the load transient without discharge it. The voltage drop due to the output capacitor discharge is given by the following equation:

$$\Delta V_{OUT} = \frac{\Delta I_{OUT}^2 \cdot L}{2 \cdot C_{OUT} \cdot (V_{INMIN} \cdot D_{MAX} - V_{OUT})}$$

Where  $D_{MAX}$  is the maximum duty cycle value that is 100%. The lower is the ESR, the lower is the output drop during load transient and the lower is the output voltage static ripple.

### Input Capacitor

The input capacitor has to sustain the ripple current produced during the on time of the upper MOS, so it must have a low ESR to minimize the losses. The rms value of this ripple is:

$$I_{rms} = I_{OUT} \sqrt{D \cdot (1 - D)}$$

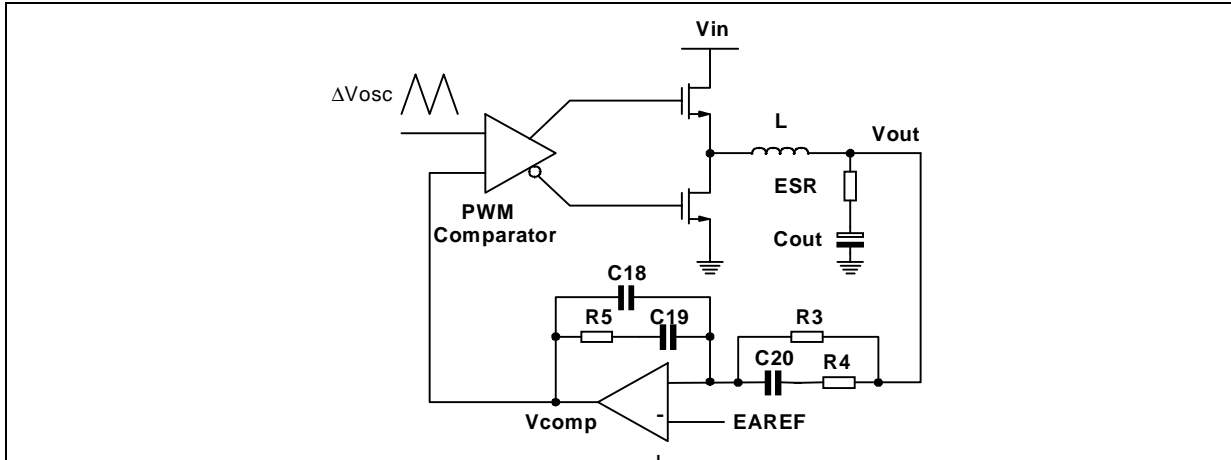
Where D is the duty cycle. The equation reaches its maximum value with  $D = 0.5$ . The losses in worst case are:

$$P = ESR \cdot I_{rms}^2$$

### Compensation network design

The control loop is a voltage mode (figure 7). The output voltage is regulated to the input Reference voltage level (EAREF). The error amplifier output  $V_{COMP}$  is then compared with the oscillator triangular wave to provide a pulse-width modulated (PWM) wave with an amplitude of  $V_{IN}$  at the PHASE node. This wave is filtered by the output filter. The modulator transfer function is the small-signal transfer function of  $V_{OUT}/V_{COMP}$ . This function has a double pole at frequency  $F_{LC}$  depending on the L- $C_{out}$  resonance and a zero at  $F_{ESR}$  depending on the output capacitor ESR. The DC Gain of the modulator is simply the input voltage  $V_{IN}$  divided by the peak-to-peak oscillator voltage  $\Delta V_{OSC}$ .

Figure 7. Compensation Network



The compensation network consists in the internal error amplifier and the impedance networks  $Z_{IN}$  (R3, R4 and C20) and  $Z_{FB}$  (R5, C18 and C19). The compensation network has to provide a closed loop transfer function with the highest 0dB crossing frequency to have fast response (but always lower than  $f_{sw}/10$ ) and the highest gain in DC conditions to minimize the load regulation.

A stable control loop has a gain crossing with -20dB/decade slope and a phase margin greater than 45°. Include worst-case component variations when determining phase margin.

To locate poles and zeroes of the compensation networks, the following suggestions may be used:

Modulator singularity frequencies:

$$\omega_{LC} = \frac{1}{\sqrt{L \cdot C_{OUT}}} \quad \omega_{ESR} = \frac{1}{ESR \cdot C_{OUT}}$$

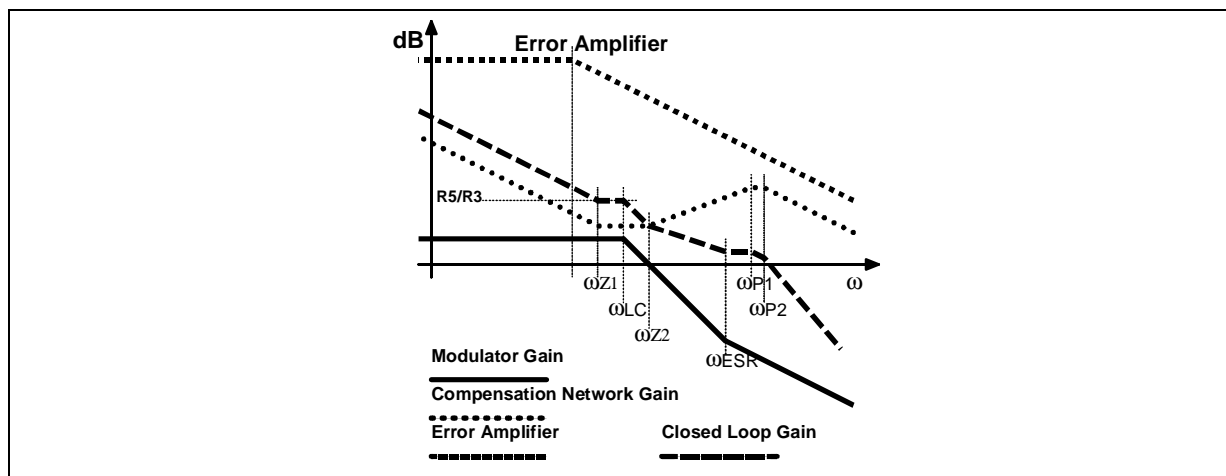
Compensation network singularity frequency:

$$\omega_{P1} = \frac{1}{R5 \cdot \left( \frac{C18 \cdot C19}{C18 + C19} \right)} \quad \omega_{P2} = \frac{1}{R4 \cdot C20}$$

$$\omega_{Z1} = \frac{1}{R5 \cdot C19} \quad \omega_{Z2} = \frac{1}{(R3 + R4) \cdot C20}$$

- Put the gain R5/R3 in order to obtain the desired converter bandwidth;
- Place  $\omega_{Z1}$  before the output filter resonance  $\omega_{LC}$ ;
- Place  $\omega_{Z2}$  at the output filter resonance  $\omega_{LC}$ ;
- Place  $\omega_{P1}$  at the output capacitor ESR zero  $\omega_{ESR}$ ;
- Place  $\omega_{P2}$  at one half of the switching frequency;
- Check the loop gain considering the error amplifier open loop gain.

Figure 8. Asymptotic Bode plot of Converter's gain



20A Demo Board Description

The demo board shows the operation of the device in a general purpose application. This evaluation board allows voltage adjustability from 0.9V to 5V through the switches S2-S5 according to the reported table when the internal 0.9V reference is used (G1 closed). Output current in excess of 20A can be reached dependently on the kind of mosfet used: up to three SO8 mosfet may be used for both High side and Low side switches. External reference may be used for the regulation simply leaving open G1 and the switches S2-S5. The device may also be disabled with the switch S1. The 12V input rail supplies the device while the power conversion starts from the 5V input rail. The device is also able to operate with a single supply voltage; in this case the jumper G2 has to be closed and a 5V to 12V input can be directly connected to the  $V_{IN}$  input. The four layers demo board's copper thickness is of  $70\mu m$  in order to minimize conduction losses considering the high current that the circuit is able to deliver. Figure 9 shows the demo board's schematic circuit

Figure 9. 20A Demo Board Schematic

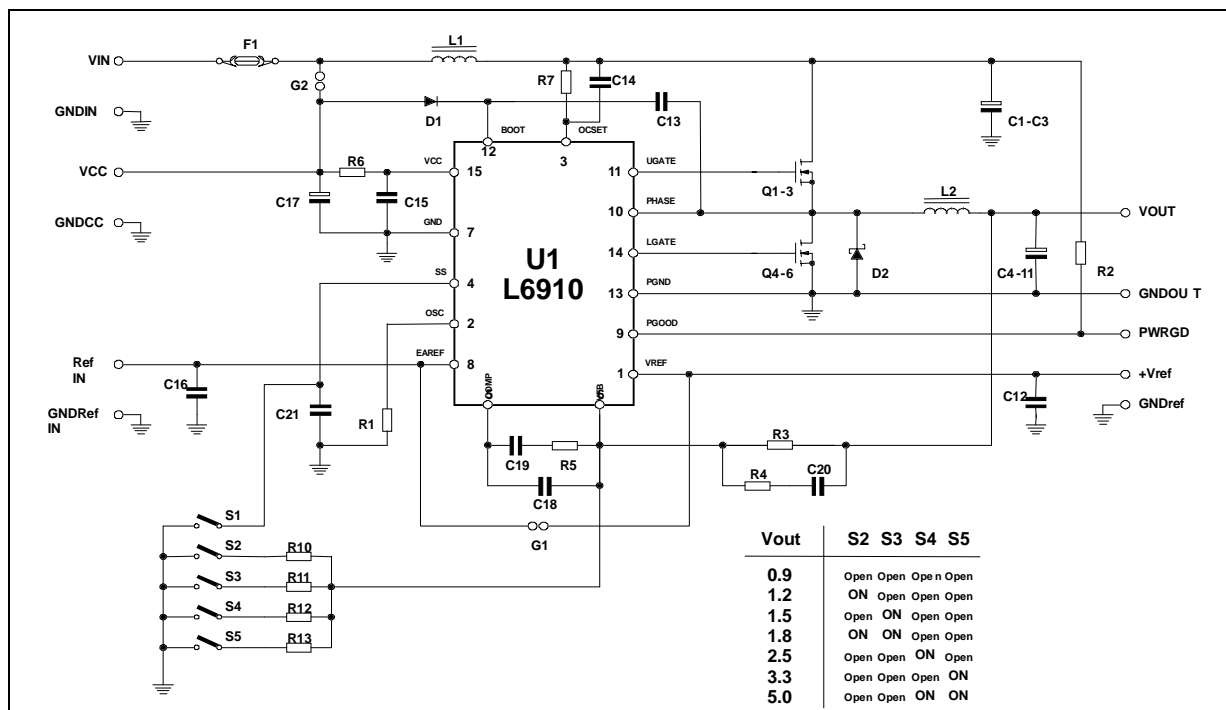


Figure 10. PCB and Components Layouts

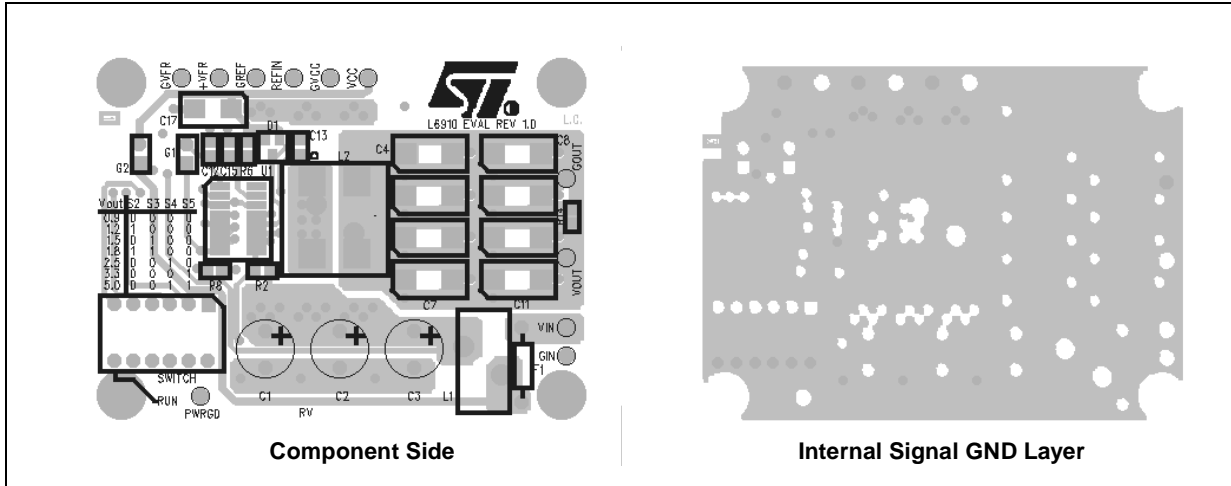
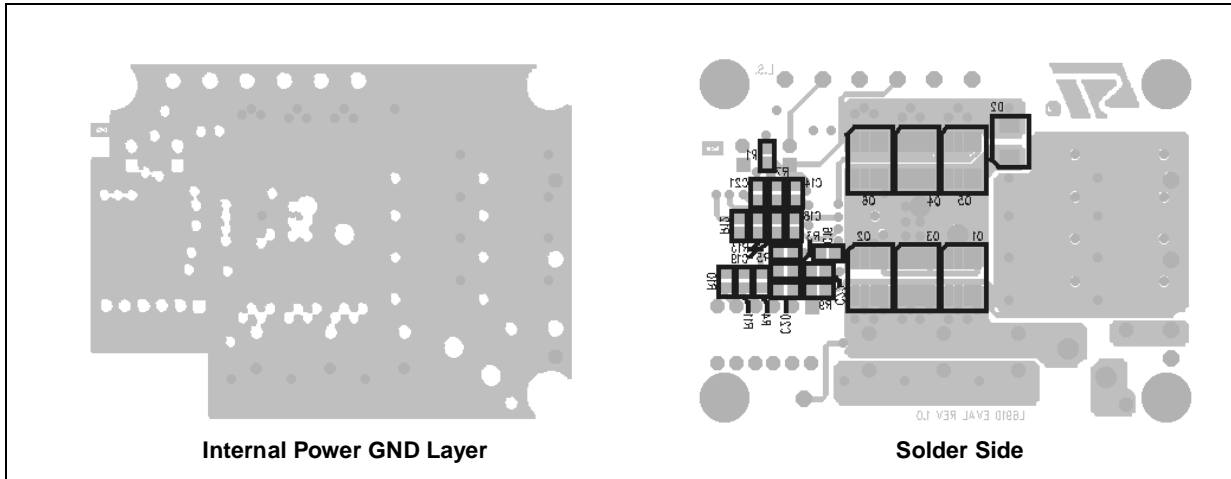


Figure 11. PCB and Components Layouts



Figures 10 and 11 show the demo board layout. Considering the flexibility in the power mosfet configuration (up to three mosfet for both high side and low side), it is possible to obtain different application idea with the same board. In the following paragraphs, it will be described the standard demo-board configuration (8A) and the high current configuration.

**APPLICATION IDEA: 5V TO 12V INPUT; 0.9V TO 5V / 8A OUTPUT**

This is a typical bus termination application in which the output voltage is programmed by the switch to 1.2V typ (it can range from 0.9V to 5V) and the maximum output current is of 8A DC. The power mosfet are configured with one STS12NF30L (30V, 10mΩ typ @ Vgs=4.5V ) for both hgh side and low side.

**Inductor selection**

Since the maximum output current is 8A, to have a 15% ripple (1A) in worst case the inductor chosen is 4.1μH. SUMIDA CEE125 series inductor has been chosen with a 4.2μA typical value.

### Output Capacitor

In the demo 5 POSCAP capacitors, model 6TPB330M, are used, with a maximum ESR equal to 40mΩ each. Therefore the resultant ESR is of 8mΩ. For load transient of 8A in the worst case the voltage drop is of:

$$\Delta V_{\text{out}} = 8 \cdot 0.008 = 64\text{mV}$$

The voltage drop due to the capacitor discharge during load transient, considering that the maximum duty cycle is equal to 100% results in 16.4mV with 1.2V of programmed output.

### Input Capacitor

For  $I_{\text{OUT}} = 8\text{A}$  and  $D=0.5$  (worst case for input ripple current),  $I_{\text{rms}}$  is equal to 4A. Three OSCON electrolytic capacitors 20SA100M, with a maximum ESR equal to 30mΩ, are chosen to sustain the ripple. Therefore, the resultant ESR is equal to 30mΩ/3 = 10mΩ. So the losses in worst case are:

$$P = \text{ESR} \cdot I_{\text{rms}}^2 = 160\text{mW}$$

### Over-Current Protection

The peak current is in this case equal to 12A, substituting the demo board parameters in the relationship reported in the relative section, ( $I_{\text{OCSMIN}} = 170\mu\text{A}$ ;  $I_{\text{P}} = 12\text{A}$ ;  $R_{\text{DSONMAX}} = 9\text{m}\Omega$ ) it results that  $R_{\text{OCS}} = 620\Omega$ .

**Table 1. Part List**

R2	10k		SMD 0805
R3	4.7k	1%	SMD 0805
R5	47k		SMD 0805
R6	10		SMD 0805
R7	620		SMD 0805
R10	14k	E96 1%	SMD 0805
R11	6.98k	E96 1% (optional)	SMD 0805
R12	2.61k	E96 1% (optional)	SMD 0805
R13	1.74k	E96 1% (optional)	SMD 0805
C1	100μ	OSCON - 20SA100M	Radial 10x10.5mm
C4...C11	330μ	POSCAP - 6TPB330M	SMD 7343
C12, C13, C15, C21	100n	Ceramic	SMD 0805
C14	1n	Ceramic	SMD 0805
C19	56n	Ceramic	SMD 0805
L1	1.5μ	T44-52 Core, 7T-18AWG	
L2	4.2μ	SUMIDA CEE125 series	
U1	L6910	STMicroelectronics	SO16 NARROW
Q1, Q4	STS12NF30L	STMicroelectronics	SO8
D1	1N4148	STMicroelectronics	SOT23
D2	STPS3340U	STMicroelectronics	SMB
F1	251015A-15°	Littlefuse	AXIAL

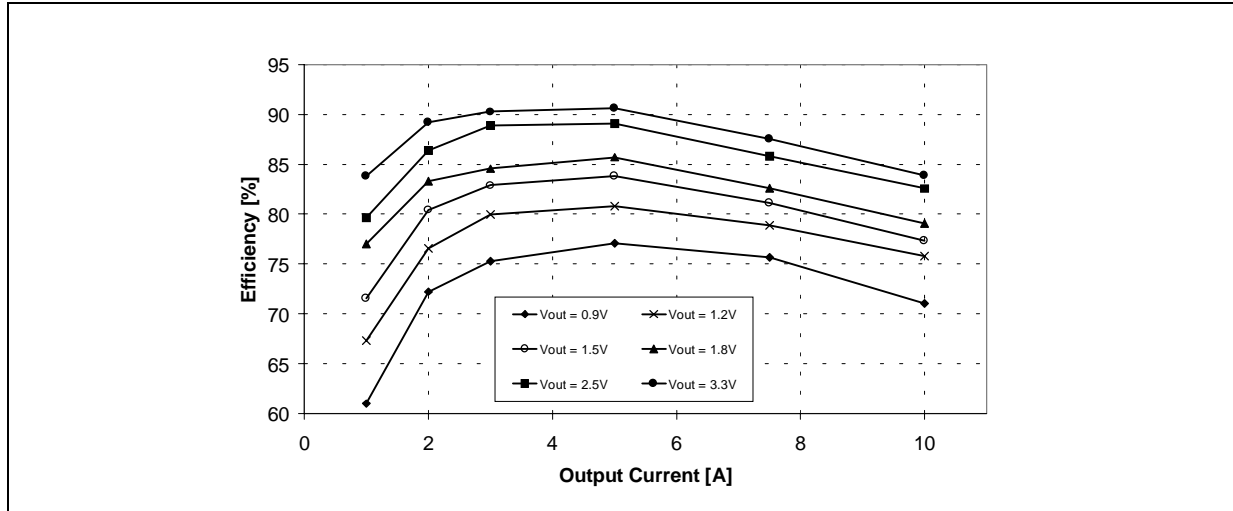
### Efficiency

Figure 12 shows the measured efficiency versus load current for different values of output voltage. The measure was done at  $V_{\text{in}} = 5\text{V}$  for different values of the output voltage (0.9V, 1.2V, 1.5V, 1.8V, 2.5V and 3.3V). IC supply voltage is of 12V.

In the application one mosfets STS12NF30L (30V, 10mΩ typ @  $V_{\text{gs}} = 4.5\text{V}$ ) is used for both the low and the high side.

Since the board has been layed out with the possibility to use up to three SO8 mosfets for both high and low side switch, to increase efficiency at low output voltages, an additional mosfet on the low side can be considered because of the duty cycle.

Figure 12. Demo Board Efficiency @  $V_{in} = 5V$



**APPLICATION IDEA: 5V TO 12V INPUT; 3.3V / 25A OUTPUT**

This is a typical application to replace the mag-amp in the silver box. The output voltage is programmed by the switch to 3.3V and the maximum output current is of 25A DC. The power mosfet are configured with three STS11NF30L (30V, 9mΩ typ @  $V_{gs} = 10V$ ) for high side and two of them for the low side.

**Inductor selection**

Since the maximum output current is 25A, to have a 20% ripple (5A) in worst case the inductor chosen is 1.1μH. An iron powder core (TO50-52B) with 6 windings has been chosen.

**Output Capacitor**

4 POSCAP capacitors, model 6TPB330M, are used, with a maximum ESR equal to 40mΩ each. Therefore the resultant ESR is of 10mΩ. For load transient of 20A in the worst case the voltage drop is lower than 5%:

$$\Delta V_{out} = 20 \cdot 0.01 = 200mV$$

**Input Capacitor**

For  $I_{OUT} = 25A$  and  $D = 0.5$  (worst case for input ripple current),  $I_{rms}$  is equal to 12.5A. Three OSCON electrolytic capacitors 6SP680M, with a maximum ESR equal to 13mΩ, are chosen to sustain the ripple. Therefore, the resultant ESR is equal to  $13m\Omega / 3 = 4.3m\Omega$ . So the losses in worst case are:

$$P = ESR \cdot I_{rms}^2 = 670mW$$

**Over-Current Protection**

The peak current is in this case equal to 30A, substituting the demo board parameters in the relationship reported in the relative section, ( $I_{OCSMIN} = 170\mu A$ ;  $I_P = 30A$ ;  $R_{DSONMAX} = 3m\Omega$ ) it results that  $R_{OCS} = 530\Omega$ .

Table 2. Part List

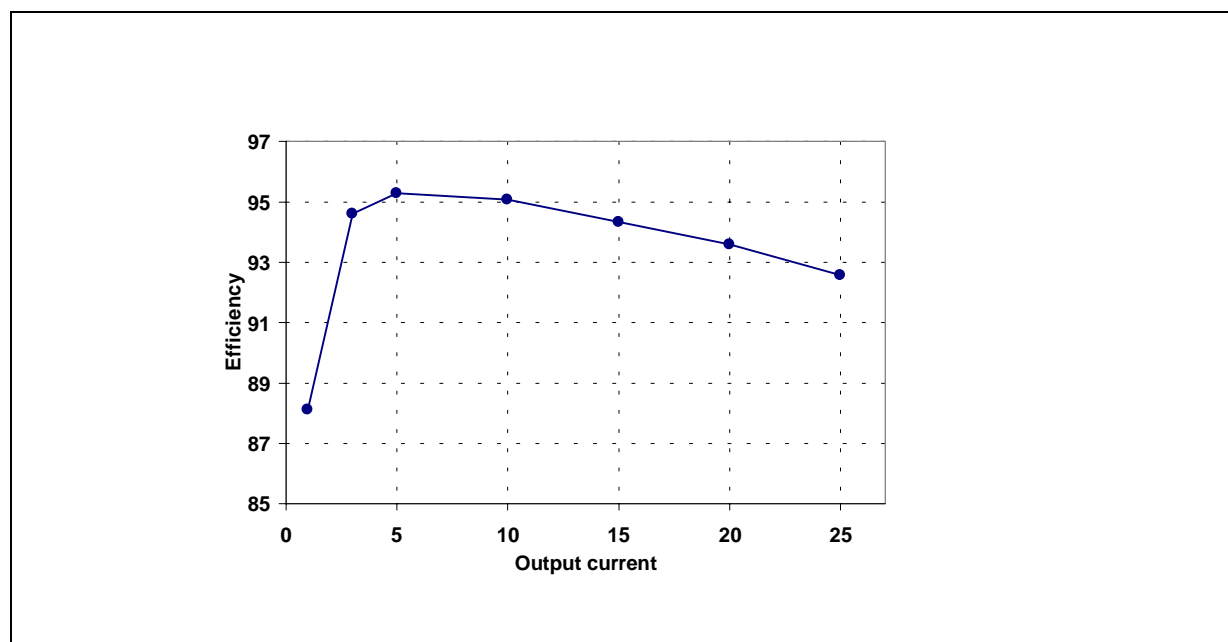
R2	10k		SMD 0805
R3	4.7k	1%	SMD 0805
R4	220		SMD 0805
R5	10k		SMD 0805
R6	10		SMD 0805
R7	620		SMD 0805
R9	0		SMD 0805
R10	1.74k	1%	SMD 0805
C1,C2, C3	680 $\mu$	OSCON - 6SP680M	Radial 10x10.5mm
C4 to C8	330 $\mu$	POSCAP - 6TPB330M	SMD 7343
C13, C15	100n	Ceramic	SMD 0805
C14, C16	1n	Ceramic	SMD 0805
C18	2.2n	Ceramic	SMD 0805
C19	3.3n	Ceramic	SMD 0805
C20	6.8n	Ceramic	SMD 0805
L1	1.5 $\mu$	T44-52 Core, 7T-18AWG	
L2	1.1 $\mu$	T50-52B Core, 6T	
U1	L6910	STMicroelectronics	SO16 NARROW
Q1 to Q5	ST511NF30L	STMicroelectronics	SO8
D1	1N4148	STMicroelectronics	SOT23
D2	STPS340U	STMicroelectronics	SMB
F1	251015A-15 $^{\circ}$	Littlefuse	AXIAL

### Efficiency

Figure 13 shows the measured efficiency versus load current at  $V_{in}=5V$ .

In the application three mosfets ST511NF30L (30V, 9m $\Omega$  typ @  $V_{gs} = 10V$ ) are used for high side swith while two of them are used for the low side..

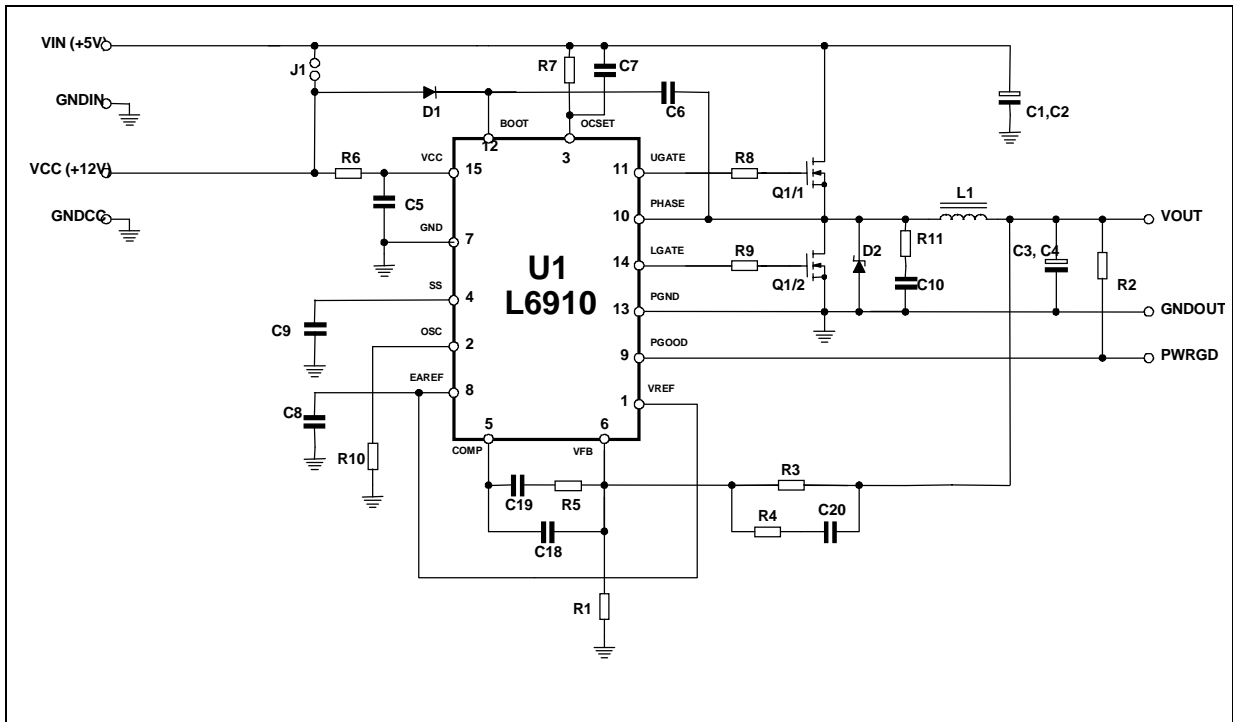
Figure 13. Demo Board Efficiency @  $V_{in} = 5V$  &  $V_{out} = 3.3V$



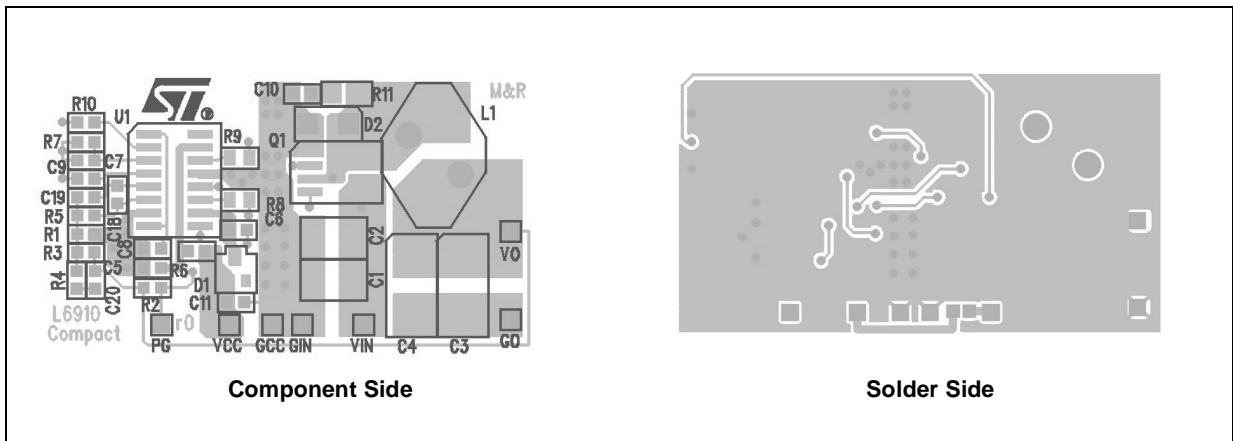
**5A Demo Board Description**

The demo board shows the operation of the device in a general purpose application. The internal reference is used for the regulation. The external power mosfets are included in one SO8 package to save space and increase power density. The 12V input rail supplies the device while the power conversion starts from the 5V input rail. The device is also able to operate with a single supply voltage; in this case the jumper J1 on the board bottom has to be closed and a 5V to 12V input can be directly connected to the  $V_{IN}$  input.

**Figure 14. 5A Demo Board Schematic**

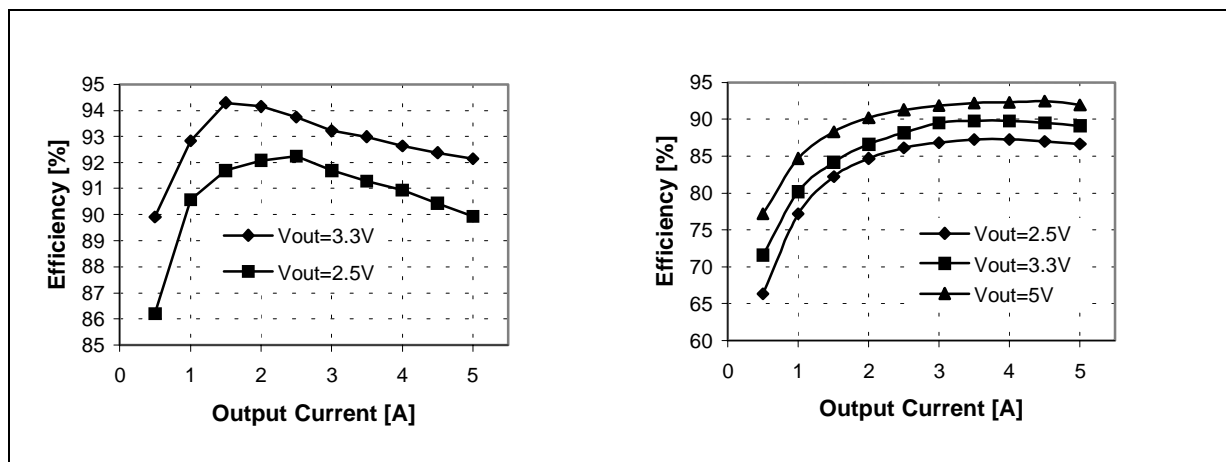


**Figure 15. PCB and Components Layouts**



**Efficiency**

Figure 16 shows the measured efficiency versus load current for different values of output voltage. The measure was done at 5V and 12V input for different values of the output voltage (2.5V, 3.3V and 5V only when  $V_{in}=12V$ ). Output voltage has been changed modifying the value of R1 in the demo board as reported in the part list.

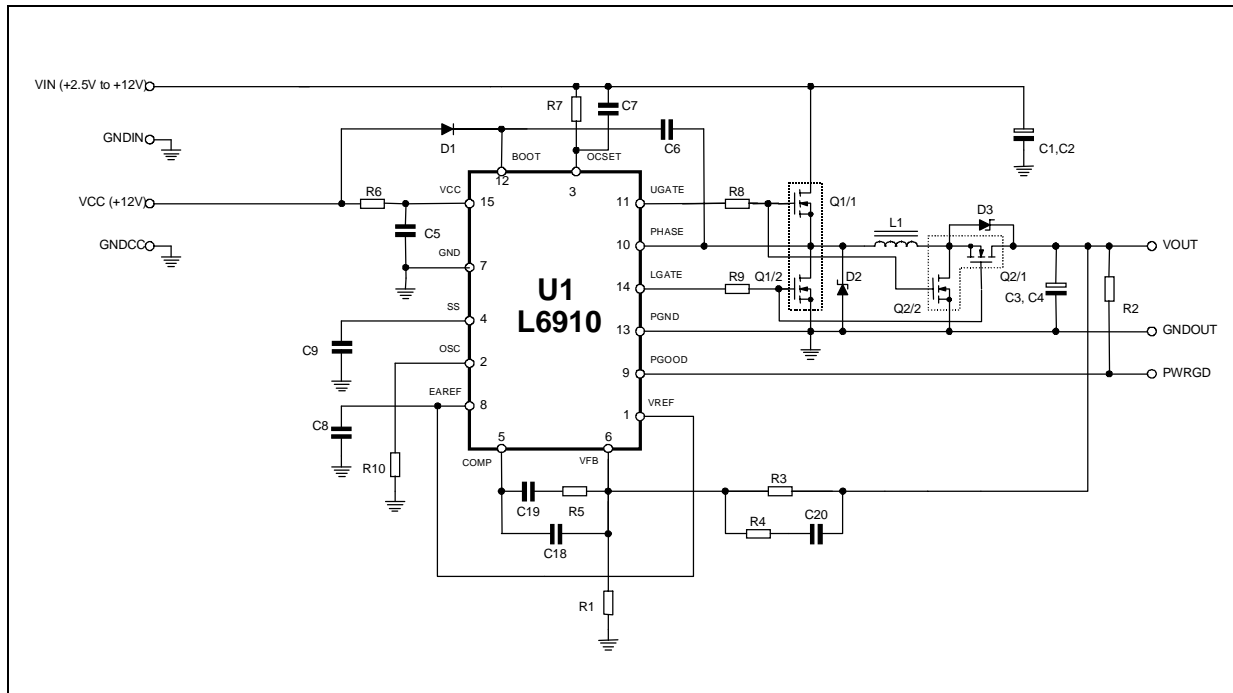
Figure 16. Demoboard efficiency with  $V_{CC} = V_{IN} = 5V$  (left), and with  $V_{CC} = V_{IN} = 12V$  (right).

## Part List

Resistors			
R1	560 375 220	1%; (Vout = 2.5V) 1%; (Vout = 3.3V) 1%; (Vout = 5V)	SMD 0805
R2	10K		SMD 0805
R3	1K		SMD 0805
R4	33		SMD 0805
R5	2.7K		SMD 0805
R6	10		SMD 0805
R7	680		SMD 0805
R8, R9	2.2		SMD 0805
Capacitors			
C1, C2	10 $\mu$ F	TOKIN C34Y5U1E106ZTE12	SMD 7343
C3, C4	100 $\mu$ F – 6.3V	POSCAP 6TPB100M	SMD 7343
C5, C6, C9	100nF		SMD 0805
C7, C8	1nF		SMD 0805
C18	1.5n		SMD 0805
C19	15n		SMD 0805
C20	47n		SMD 0805
Magnetics			
L1	10 $\mu$ H	T50-52B Core, 12T	
Transistors			
Q1	STS7DNF30L	STMicroelectronics	SO8
Diodes			
D1	1N4148		SOT23
D2	STPS125A	STMicroelectronics	SMA
Ics			
U1	L6910	STMicroelectronics	SO16Narrow

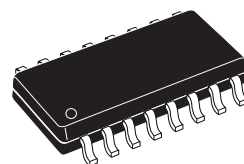
APPLICATION IDEA: BUCK-BOOST CONVERTER 3V TO 10V INPUT / 5V 2A OUTPUT

Figure 17. buck-boost converter 3V to 10V input / 5V 2A Output Circuit



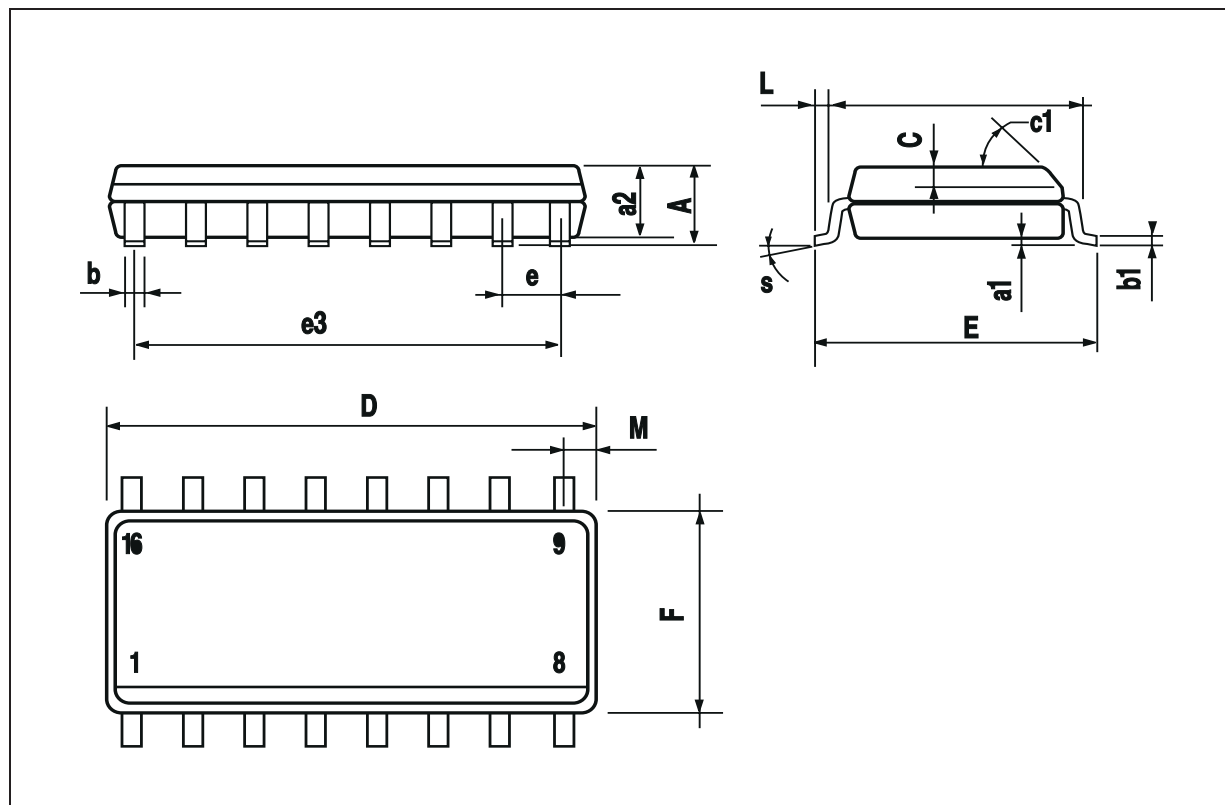
DIM.	mm			inch		
	MIN.	TYP.	MAX.	MIN.	TYP.	MAX.
A			1.75			0.069
a1	0.1		0.25	0.004		0.009
a2			1.6			0.063
b	0.35		0.46	0.014		0.018
b1	0.19		0.25	0.007		0.010
C		0.5			0.020	
c1	45° (typ.)					
D (1)	9.8		10	0.386		0.394
E	5.8		6.2	0.228		0.244
e		1.27			0.050	
e3		8.89			0.350	
F (1)	3.8		4	0.150		0.157
G	4.6		5.3	0.181		0.209
L	0.4		1.27	0.016		0.050
M			0.62			0.024
S	8°(max.)					

## OUTLINE AND MECHANICAL DATA



## SO16 Narrow

(1) D and F do not include mold flash or protrusions. Mold flash or protrusions shall not exceed 0.15mm (.006inch).



Information furnished is believed to be accurate and reliable. However, STMicroelectronics assumes no responsibility for the consequences of use of such information nor for any infringement of patents or other rights of third parties which may result from its use. No license is granted by implication or otherwise under any patent or patent rights of STMicroelectronics. Specifications mentioned in this publication are subject to change without notice. This publication supersedes and replaces all information previously supplied. STMicroelectronics products are not authorized for use as critical components in life support devices or systems without express written approval of STMicroelectronics.

The ST logo is a registered trademark of STMicroelectronics  
© 2002 STMicroelectronics - All Rights Reserved

STMicroelectronics GROUP OF COMPANIES  
Australia - Brazil - Canada - China - Finland - France - Germany - Hong Kong - India - Israel - Italy - Japan -Malaysia - Malta - Morocco -  
Singapore - Spain - Sweden - Switzerland - United Kingdom - United States.  
<http://www.st.com>