

---

**5V, 64 Kbit (8Kb x 8) ZEROPOWER<sup>®</sup> SRAM**

---

**FEATURES SUMMARY**

- INTEGRATED, ULTRA LOW POWER SRAM AND POWER-FAIL CONTROL CIRCUIT
- UNLIMITED WRITE CYCLES
- READ CYCLE TIME EQUALS WRITE CYCLE TIME
- AUTOMATIC POWER-FAIL CHIP DESELECT AND WRITE PROTECTION
- WRITE PROTECT VOLTAGES  
( $V_{PFD}$  = Power-fail Deselect Voltage):
  - M48Z08:  $V_{CC} = 4.75$  to  $5.5V$   
 $4.5V \leq V_{PFD} \leq 4.75V$
  - M48Z18:  $V_{CC} = 4.5$  to  $5.5V$   
 $4.2V \leq V_{PFD} \leq 4.5V$
- SELF-CONTAINED BATTERY IN THE CAPHAT<sup>™</sup> DIP PACKAGE
- PIN AND FUNCTION COMPATIBLE WITH JEDEC STANDARD 8K x 8 SRAMs

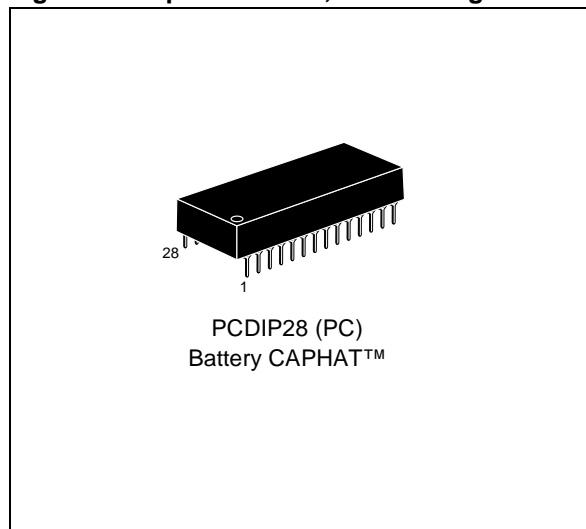
**Figure 1. 28-pin CAPHAT, DIP Package**

## TABLE OF CONTENTS

FEATURES SUMMARY .....	1
SUMMARY DESCRIPTION.....	4
MAXIMUM RATING.....	5
DC AND AC PARAMETERS.....	6
OPERATION MODES .....	7
READ Mode .....	8
WRITE Mode.....	9
Data Retention Mode.....	11
V <sub>CC</sub> Noise And Negative Going Transients.....	12
PACKAGE MECHANICAL INFORMATION .....	13
PART NUMBERING .....	14
REVISION HISTORY.....	15

## SUMMARY DESCRIPTION

The M48Z08/18 ZEROPOWER® RAM is a 8K x 8 non-volatile static RAM which is pin and functional compatible with the DS1225.

The monolithic chip is available in two special packages to provide a highly integrated battery backed-up memory solution.

The M48Z08/18 is a non-volatile pin and function equivalent to any JEDEC standard 8K x 8 SRAM.

It also easily fits into many ROM, EPROM, and EEPROM sockets, providing the non-volatility of PROMs without any requirement for special write timing or limitations on the number of writes that can be performed.

The 28-pin, 600mil DIP CAPHAT™ houses the M48Z08/18 silicon with a long life lithium button cell in a single package.

Figure 2. Logic Diagram

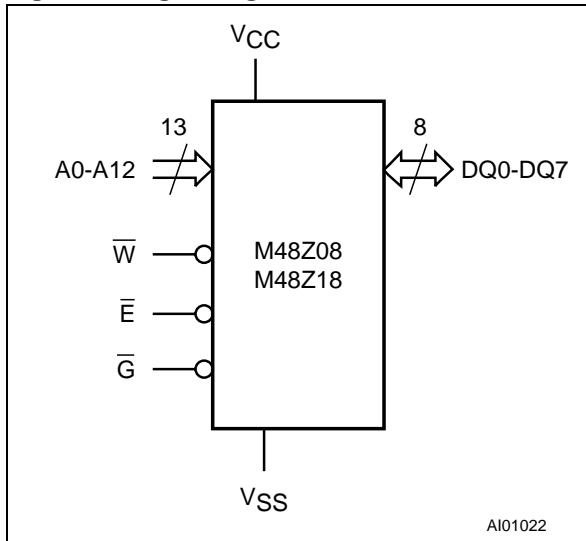

Table 1. Signal Names

A0-A12	Address Inputs
DQ0-DQ7	Data Inputs / Outputs
$\bar{E}$	Chip Enable
$\bar{G}$	Output Enable
$\bar{W}$	WRITE Enable
V <sub>CC</sub>	Supply Voltage
V <sub>SS</sub>	Ground
NC	Not Connected Internally

Figure 3. DIP Connections

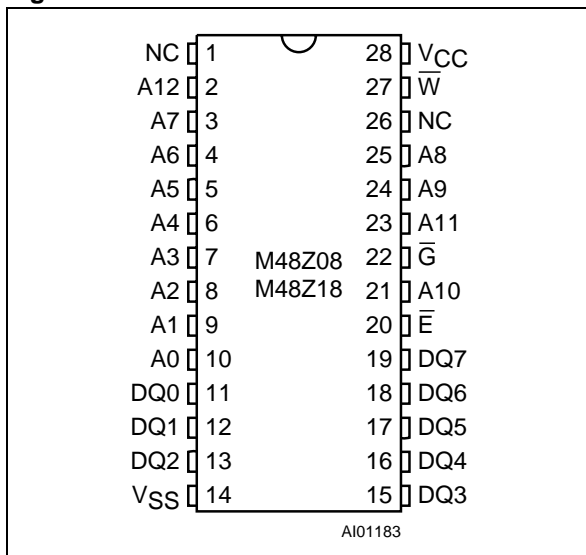
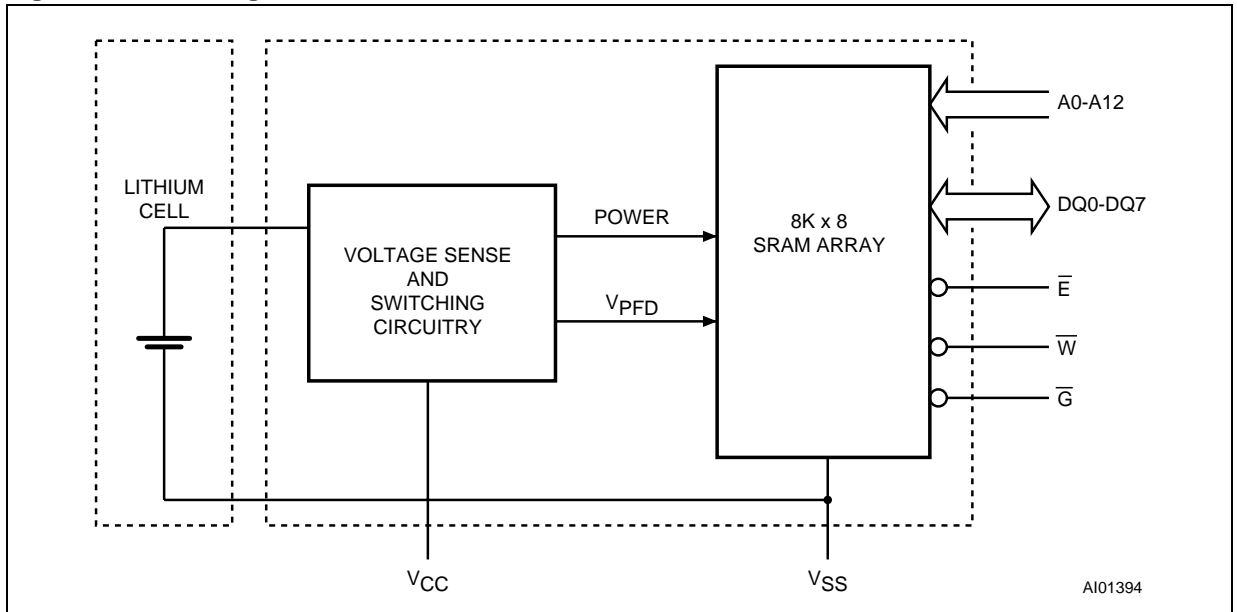

Figure 4. Block Diagram



## MAXIMUM RATING

Stressing the device above the rating listed in the “Absolute Maximum Ratings” table may cause permanent damage to the device. These are stress ratings only and operation of the device at these or any other conditions above those indicated in the Operating sections of this specification is

not implied. Exposure to Absolute Maximum Rating conditions for extended periods may affect device reliability. Refer also to the STMicroelectronics SURE Program and other relevant quality documents.

Table 2. Absolute Maximum Ratings

Symbol	Parameter	Value	Unit
T <sub>A</sub>	Ambient Operating Temperature	0 to 70	°C
T <sub>STG</sub>	Storage Temperature (V <sub>CC</sub> Off, Oscillator Off)	-40 to 85	°C
T <sub>SLD</sub> <sup>(1)</sup>	Lead Solder Temperature for 10 seconds	260	°C
V <sub>IO</sub>	Input or Output Voltages	-0.3 to 7	V
V <sub>CC</sub>	Supply Voltage	-0.3 to 7	V
I <sub>O</sub>	Output Current	20	mA
P <sub>D</sub>	Power Dissipation	1	W

Note: 1. For DIP package: Soldering temperature not to exceed 260°C for 10 seconds (total thermal budget not to exceed 150°C for longer than 30 seconds).

**CAUTION:** Negative undershoots below -0.3V are not allowed on any pin while in the Battery Back-up mode.

## DC AND AC PARAMETERS

This section summarizes the operating and measurement conditions, as well as the DC and AC characteristics of the device. The parameters in the following DC and AC Characteristic tables are derived from tests performed under the Measure-

ment Conditions listed in the relevant tables. Designers should check that the operating conditions in their projects match the measurement conditions when using the quoted parameters.

**Table 3. Operating and AC Measurement Conditions**

Parameter	M48Z08	M48Z18	Unit
Supply Voltage ( $V_{CC}$ )	4.75 to 5.5	4.5 to 5.5	V
Ambient Operating Temperature ( $T_A$ )	0 to 70	0 to 70	°C
Load Capacitance ( $C_L$ )	100	100	pF
Input Rise and Fall Times	$\leq 5$	$\leq 5$	ns
Input Pulse Voltages	0 to 3	0 to 3	V
Input and Output Timing Ref. Voltages	1.5	1.5	V

Note: Output Hi-Z is defined as the point where data is no longer driven.

**Figure 5. AC Testing Load Circuit**

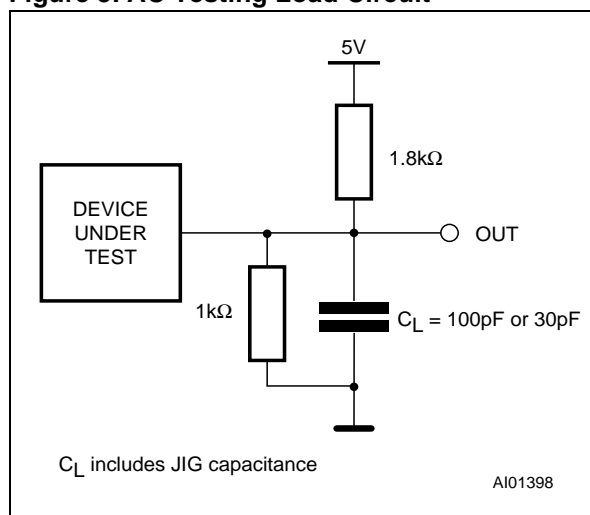

**Table 4. Capacitance**

Symbol	Parameter <sup>(1,2)</sup>	Min	Max	Unit
$C_{IN}$	Input Capacitance		10	pF
$C_{IO}^{(3)}$	Input / Output Capacitance		10	pF

Note: 1. Effective capacitance measured with power supply at 5V; sampled only, not 100% tested.

2. At 25°C,  $f = 1\text{MHz}$ .

3. Outputs deselected.

**Table 5. DC Characteristics**

Symbol	Parameter	Test Condition <sup>(1)</sup>	Min	Max	Unit
$I_{LI}$	Input Leakage Current	$0V \leq V_{IN} \leq V_{CC}$		$\pm 1$	$\mu A$
$I_{LO}^{(2)}$	Output Leakage Current	$0V \leq V_{OUT} \leq V_{CC}$		$\pm 1$	$\mu A$
$I_{CC}$	Supply Current	Outputs open		80	mA
$I_{CC1}$	Supply Current (Standby) TTL	$\bar{E} = V_{IH}$		3	mA
$I_{CC2}$	Supply Current (Standby) CMOS	$\bar{E} = V_{CC} - 0.2V$		3	mA
$V_{IL}^{(3)}$	Input Low Voltage		-0.3	0.8	V
$V_{IH}$	Input High Voltage		2.2	$V_{CC} + 0.3$	V
$V_{OL}$	Output Low Voltage	$I_{OL} = 2.1mA$		0.4	V
$V_{OH}$	Output High Voltage	$I_{OH} = -1mA$	2.4		V

Note: 1. Valid for Ambient Operating Temperature:  $T_A = 0$  to  $70^\circ C$ ;  $V_{CC} = 4.75$  to  $5.5V$  or  $4.5$  to  $5.5V$  (except where noted).

2. Outputs deselected.

3. Negative spikes of  $-1V$  allowed for up to 10ns once per Cycle.

## OPERATION MODES

The M48Z08/18 also has its own Power-fail Detect circuit. The control circuitry constantly monitors the single 5V supply for an out of tolerance condition. When  $V_{CC}$  is out of tolerance, the circuit write protects the SRAM, providing a high degree of

data security in the midst of unpredictable system operation brought on by low  $V_{CC}$ . As  $V_{CC}$  falls below approximately 3V, the control circuitry connects the battery which maintains data until valid power returns.

**Table 6. Operating Modes**

Mode	$V_{CC}$	$\bar{E}$	$\bar{G}$	$\bar{W}$	DQ0-DQ7	Power
Deselect	4.75 to 5.5V or 4.5 to 5.5V	$V_{IH}$	X	X	High Z	Standby
WRITE		$V_{IL}$	X	$V_{IL}$	$D_{IN}$	Active
READ		$V_{IL}$	$V_{IL}$	$V_{IH}$	$D_{OUT}$	Active
READ		$V_{IL}$	$V_{IH}$	$V_{IH}$	High Z	Active
Deselect	$V_{SO}$ to $V_{PFD}(\min)^{(1)}$	X	X	X	High Z	CMOS Standby
Deselect	$\leq V_{SO}^{(1)}$	X	X	X	High Z	Battery Back-up Mode

Note: X =  $V_{IH}$  or  $V_{IL}$ ;  $V_{SO}$  = Battery Back-up Switchover Voltage.

1. See [Table 10.](#), [page 11](#) for details.

## READ Mode

The M48Z08/18 is in the READ Mode whenever  $\overline{W}$  (WRITE Enable) is high and  $\overline{E}$  (Chip Enable) is low. The device architecture allows ripple-through access of data from eight of 65,536 locations in the static storage array. Thus, the unique address specified by the 13 address inputs defines which one of the 8,192 bytes of data is to be accessed. Valid data will be available at the Data I/O pins within address access time ( $t_{AVQV}$ ) after the last address input signal is stable, providing that the  $\overline{E}$  and  $\overline{G}$  access times are also satisfied. If the  $\overline{E}$  and  $\overline{G}$  access times are not met, valid data will be

available after the latter of the Chip Enable Access time ( $t_{ELQV}$ ) or Output Enable Access time ( $t_{GLQV}$ ).

The state of the eight three-state Data I/O signals is controlled by  $\overline{E}$  and  $\overline{G}$ . If the outputs are activated before  $t_{AVQV}$ , the data lines will be driven to an indeterminate state until  $t_{AVQV}$ . If the address inputs are changed while  $\overline{E}$  and  $\overline{G}$  remain active, output data will remain valid for Output Data Hold time ( $t_{AXQX}$ ) but will go indeterminate until the next address access.

Figure 6. READ Mode AC Waveforms

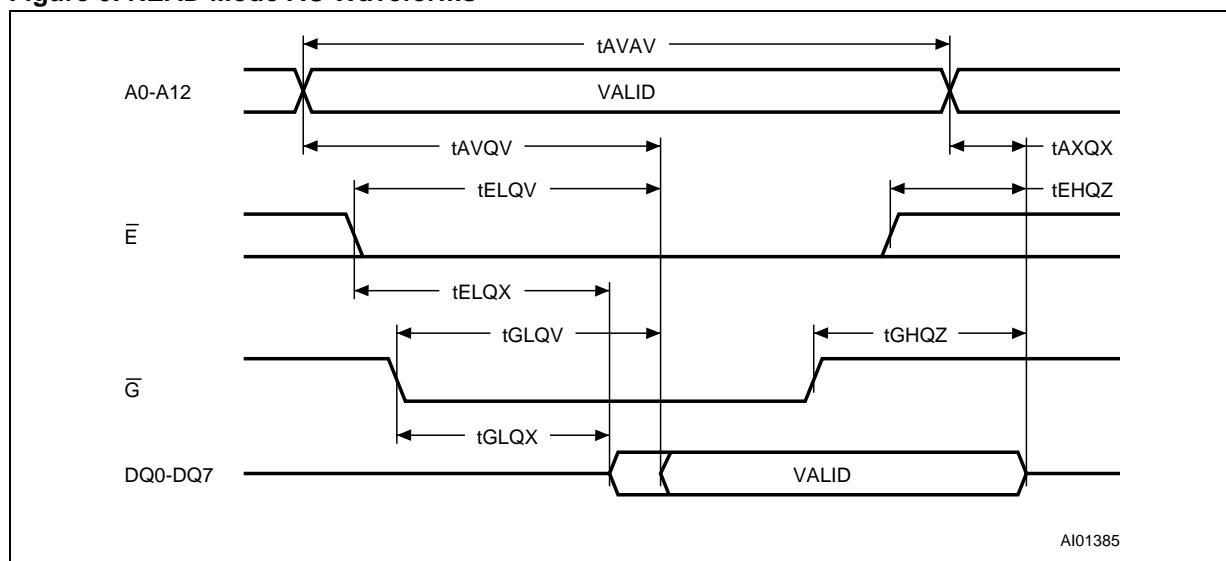

Note: WRITE Enable ( $\overline{W}$ ) = High.

Table 7. READ Mode AC Characteristics

Symbol	Parameter <sup>(1)</sup>	M48Z08/M48Z18		Unit
		Min	Max	
$t_{AVAV}$	READ Cycle Time	100		ns
$t_{AVQV}$	Address Valid to Output Valid		100	ns
$t_{ELQV}$	Chip Enable Low to Output Valid		100	ns
$t_{GLQV}$	Output Enable Low to Output Valid		50	ns
$t_{ELQX}^{(2)}$	Chip Enable Low to Output Transition	10		ns
$t_{GLQX}^{(2)}$	Output Enable Low to Output Transition	5		ns
$t_{EHQZ}^{(2)}$	Chip Enable High to Output Hi-Z		50	ns
$t_{GHQZ}^{(2)}$	Output Enable High to Output Hi-Z		40	ns
$t_{AXQX}$	Address Transition to Output Transition	5		ns

Note: 1. Valid for Ambient Operating Temperature:  $T_A = 0$  to  $70^\circ\text{C}$ ;  $V_{CC} = 4.75$  to  $5.5\text{V}$  or  $4.5$  to  $5.5\text{V}$  (except where noted).

2.  $C_L = 30\text{pF}$ .

**WRITE Mode**

The M48Z08/18 is in the WRITE Mode whenever  $\overline{W}$  and  $\overline{E}$  are active. The start of a WRITE is referenced from the latter occurring falling edge of  $\overline{W}$  or  $\overline{E}$ .

A WRITE is terminated by the earlier rising edge of  $\overline{W}$  or  $\overline{E}$ . The addresses must be held valid throughout the cycle.  $\overline{E}$  or  $\overline{W}$  must return high for a minimum of  $t_{EHAX}$  from Chip Enable or  $t_{WHAX}$  from

WRITE Enable prior to the initiation of another READ or WRITE cycle. Data-in must be valid  $t_{DVWH}$  prior to the end of WRITE and remain valid for  $t_{WHDX}$  afterward.  $\overline{G}$  should be kept high during WRITE cycles to avoid bus contention; although, if the output bus has been activated by a low on  $\overline{E}$  and  $\overline{G}$ , a low on  $\overline{W}$  will disable the outputs  $t_{WLQZ}$  after  $\overline{W}$  falls.

**Figure 7. WRITE Enable Controlled, WRITE Mode AC Waveform**

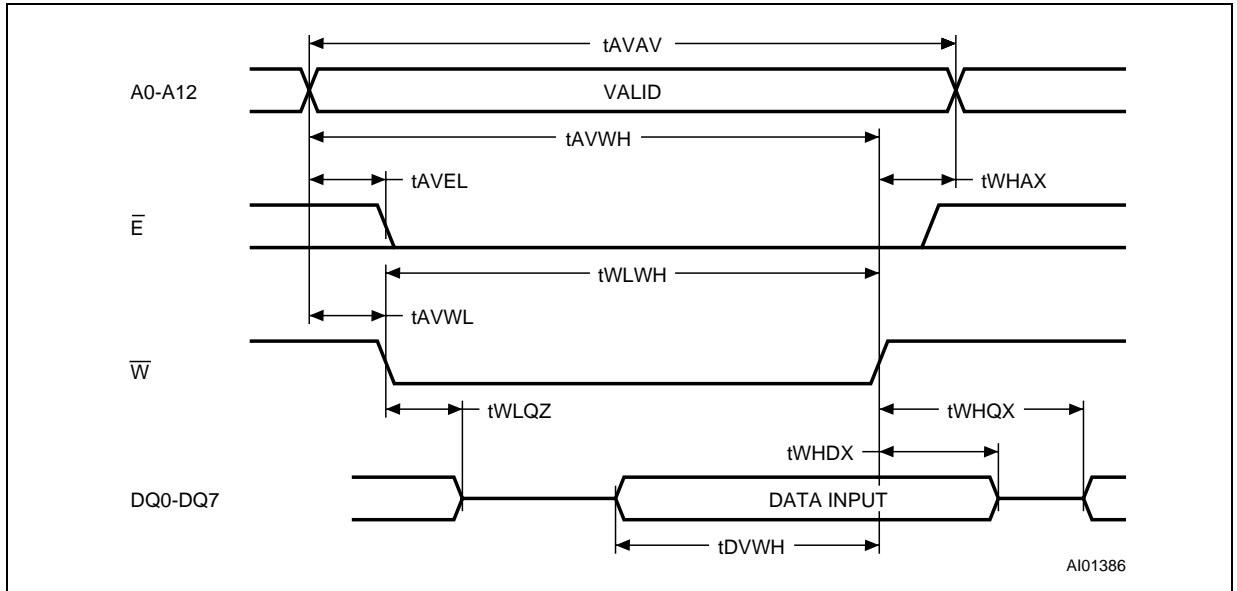

**Figure 8. Chip Enable Controlled, WRITE Mode AC Waveforms**

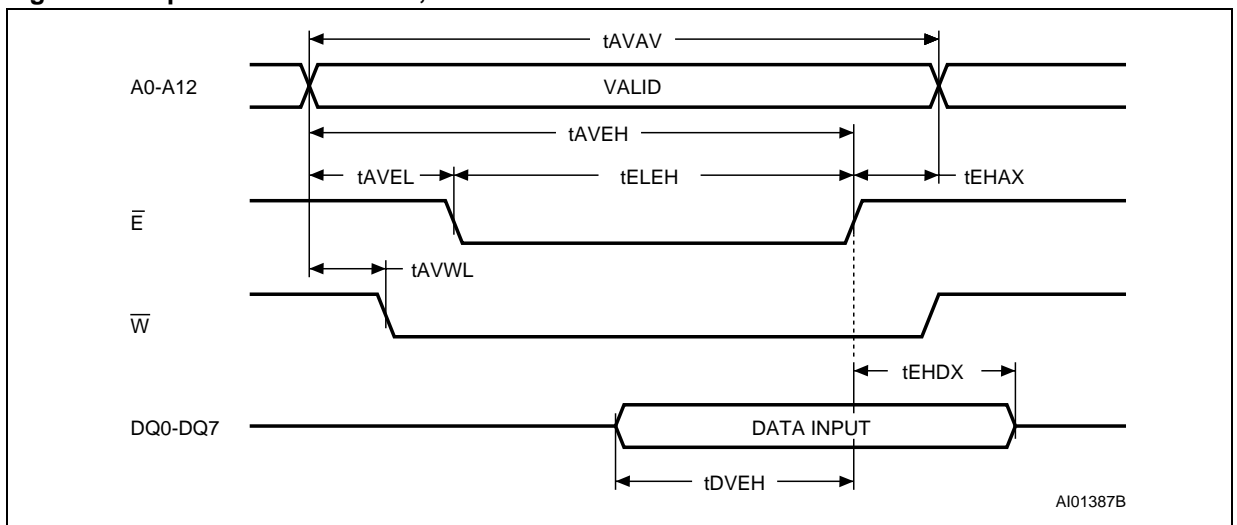

Table 8. WRITE Mode AC Characteristics

Symbol	Parameter <sup>(1)</sup>	M48Z08/M48Z18		Unit
		Min	Max	
t <sub>AVAV</sub>	WRITE Cycle Time	100		ns
t <sub>AVWL</sub>	Address Valid to WRITE Enable Low	0		ns
t <sub>AVEL</sub>	Address Valid to Chip Enable 1 Low	0		ns
t <sub>WLWH</sub>	WRITE Enable Pulse Width	80		ns
t <sub>ELEH</sub>	Chip Enable Low to Chip Enable 1 High	80		ns
t <sub>WHAX</sub>	WRITE Enable High to Address Transition	10		ns
t <sub>EHAX</sub>	Chip Enable High to Address Transition	10		ns
t <sub>DVWH</sub>	Input Valid to WRITE Enable High	50		ns
t <sub>DVEH</sub>	Input Valid to Chip Enable 1 High	30		ns
t <sub>WHDX</sub>	WRITE Enable High to Input Transition	5		ns
t <sub>EHDX</sub>	Chip Enable High to Input Transition	5		ns
t <sub>WLQZ</sub> <sup>(2,3)</sup>	WRITE Enable Low to Output Hi-Z		50	ns
t <sub>AVWH</sub>	Address Valid to WRITE Enable High	80		ns
t <sub>AVEH</sub>	Address Valid to Chip Enable High	80		ns
t <sub>WHQX</sub> <sup>(2,3)</sup>	WRITE Enable High to Output Transition	10		ns

Note: 1. Valid for Ambient Operating Temperature: T<sub>A</sub> = 0 to 70°C; V<sub>CC</sub> = 4.75 to 5.5V or 4.5 to 5.5V (except where noted).

2. C<sub>L</sub> = 30pF.

3. If  $\bar{E}$  goes low simultaneously with  $\bar{W}$  going low, the outputs remain in the high impedance state.

**Data Retention Mode**

With valid  $V_{CC}$  applied, the M48Z08/18 operates as a conventional BYTEWIDE™ static RAM. Should the supply voltage decay, the RAM will automatically power-fail deselect, write protecting itself when  $V_{CC}$  falls within the  $V_{PFD}$  (max),  $V_{PFD}$  (min) window. All outputs become high impedance, and all inputs are treated as “Don't care.”

**Note:** A power failure during a WRITE cycle may corrupt data at the currently addressed location, but does not jeopardize the rest of the RAM's content. At voltages below  $V_{PFD}$  (min), the user can be assured the memory will be in a write protected state, provided the  $V_{CC}$  fall time is not less than  $t_F$ . The M48Z08/18 may respond to transient noise spikes on  $V_{CC}$  that reach into the deselect window during the time the device is sampling  $V_{CC}$ . There-

fore, decoupling of the power supply lines is recommended.

When  $V_{CC}$  drops below  $V_{SO}$ , the control circuit switches power to the internal battery which preserves data. The internal button cell will maintain data in the M48Z08/18 for an accumulated period of at least 11 years when  $V_{CC}$  is less than  $V_{SO}$ .

As system power returns and  $V_{CC}$  rises above  $V_{SO}$ , the battery is disconnected, and the power supply is switched to external  $V_{CC}$ . Write protection continues until  $V_{CC}$  reaches  $V_{PFD}$  (min) plus  $t_{REC}$  (min).  $\bar{E}$  should be kept high as  $V_{CC}$  rises past  $V_{PFD}$  (min) to prevent inadvertent write cycles prior to system stabilization. Normal RAM operation can resume  $t_{REC}$  after  $V_{CC}$  exceeds  $V_{PFD}$  (max).

For more information on Battery Storage Life refer to the Application Note AN1012.

**Figure 9. Power Down/Up Mode AC Waveforms**

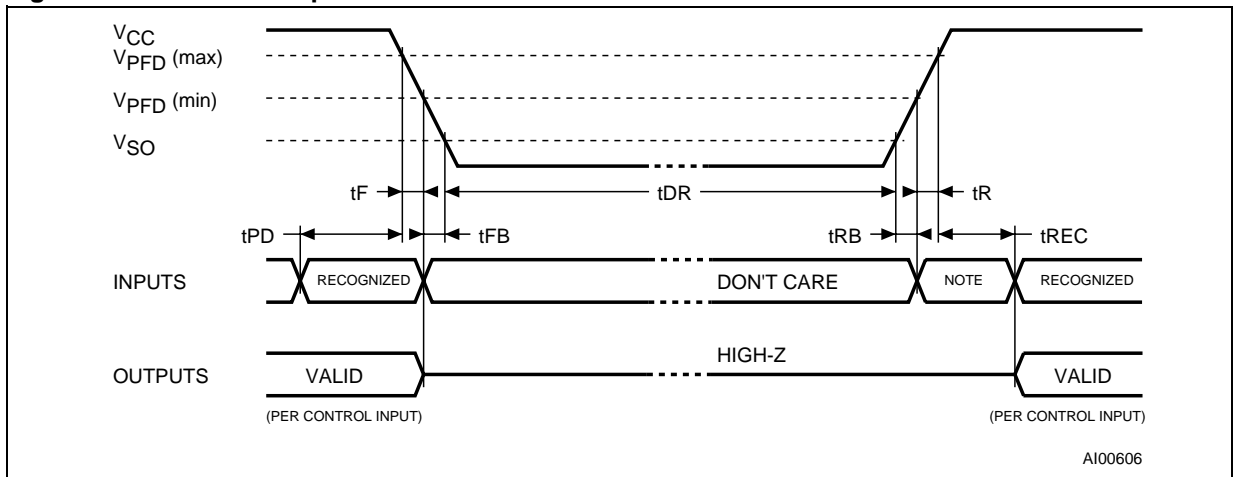

Note: Inputs may or may not be recognized at this time. Caution should be taken to keep  $\bar{E}$  high as  $V_{CC}$  rises past  $V_{PFD}$  (min). Some systems may perform inadvertent WRITE cycles after  $V_{CC}$  rises above  $V_{PFD}$  (min) but before normal system operations begin. Even though a power on reset is being applied to the processor, a reset condition may not occur until after the system is running.

**Table 9. Power Down/Up AC Characteristics**

Symbol	Parameter <sup>(1)</sup>	Min	Max	Unit
$t_{PD}$	$\bar{E}$ or $\bar{W}$ at $V_{IH}$ before Power Down	0		$\mu s$
$t_F^{(2)}$	$V_{PFD}$ (max) to $V_{PFD}$ (min) $V_{CC}$ Fall Time	300		$\mu s$
$t_{FB}^{(3)}$	$V_{PFD}$ (min) to $V_{SS}$ $V_{CC}$ Fall Time	10		$\mu s$
$t_R$	$V_{PFD}$ (min) to $V_{PFD}$ (max) $V_{CC}$ Rise Time	0		$\mu s$
$t_{RB}$	$V_{SS}$ to $V_{PFD}$ (min) $V_{CC}$ Rise Time	1		$\mu s$
$t_{REC}$	$\bar{E}$ or $\bar{W}$ at $V_{IH}$ before Power Up	2		ms

Note: 1. Valid for Ambient Operating Temperature:  $T_A = 0$  to  $70^\circ C$ ;  $V_{CC} = 4.75$  to  $5.5V$  or  $4.5$  to  $5.5V$  (except where noted).  
 2.  $V_{PFD}$  (max) to  $V_{PFD}$  (min) fall time of less than  $t_F$  may result in deselection/write protection not occurring until  $200\mu s$  after  $V_{CC}$  passes  $V_{PFD}$  (min).  
 3.  $V_{PFD}$  (min) to  $V_{SS}$  fall time of less than  $t_{FB}$  may cause corruption of RAM data.

**Table 10. Power Down/Up Trip Points DC Characteristics**

Symbol	Parameter <sup>(1,2)</sup>	Min	Typ	Max	Unit	
$V_{\text{PFD}}$	Power-fail Deselect Voltage	M48Z08	4.5	4.6	4.75	V
		M48Z18	4.2	4.3	4.5	V
$V_{\text{SO}}$	Battery Back-up Switchover Voltage		3.0		V	
$t_{\text{DR}}^{(3)}$	Expected Data Retention Time	11			YEARS	

Note: 1. All voltages referenced to  $V_{\text{SS}}$ .

2. Valid for Ambient Operating Temperature:  $T_{\text{A}} = 0$  to  $70^{\circ}\text{C}$ ;  $V_{\text{CC}} = 4.75$  to  $5.5\text{V}$  or  $4.5$  to  $5.5\text{V}$  (except where noted).

3. At  $25^{\circ}\text{C}$ ,  $V_{\text{CC}} = 0\text{V}$ .

### **$V_{\text{CC}}$ Noise And Negative Going Transients**

$I_{\text{CC}}$  transients, including those produced by output switching, can produce voltage fluctuations, resulting in spikes on the  $V_{\text{CC}}$  bus. These transients can be reduced if capacitors are used to store energy which stabilizes the  $V_{\text{CC}}$  bus. The energy stored in the bypass capacitors will be released as low going spikes are generated or energy will be absorbed when overshoots occur. A ceramic bypass capacitor value of  $0.1\mu\text{F}$  (as shown in Figure 10) is recommended in order to provide the needed filtering.

In addition to transients that are caused by normal SRAM operation, power cycling can generate negative voltage spikes on  $V_{\text{CC}}$  that drive it to values below  $V_{\text{SS}}$  by as much as one volt. These negative spikes can cause data corruption in the SRAM while in battery backup mode. To protect from these voltage spikes, STMicroelectronics recommends connecting a schottky diode from  $V_{\text{CC}}$  to  $V_{\text{SS}}$  (cathode connected to  $V_{\text{CC}}$ , anode to  $V_{\text{SS}}$ ). Schottky diode 1N5817 is recommended for through hole and MBR120T3 is recommended for surface mount.

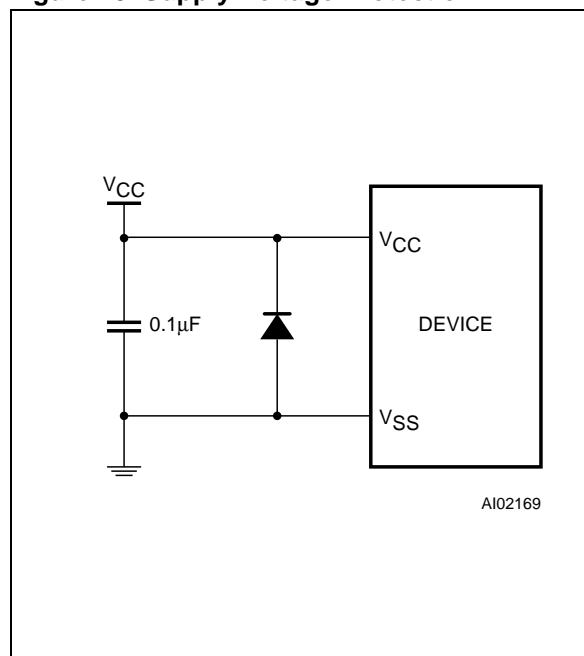
**Figure 10. Supply Voltage Protection**

## PACKAGE MECHANICAL INFORMATION

Figure 11. PCDIP28 – 28-pin Plastic DIP, battery CAPHAT, Package Outline

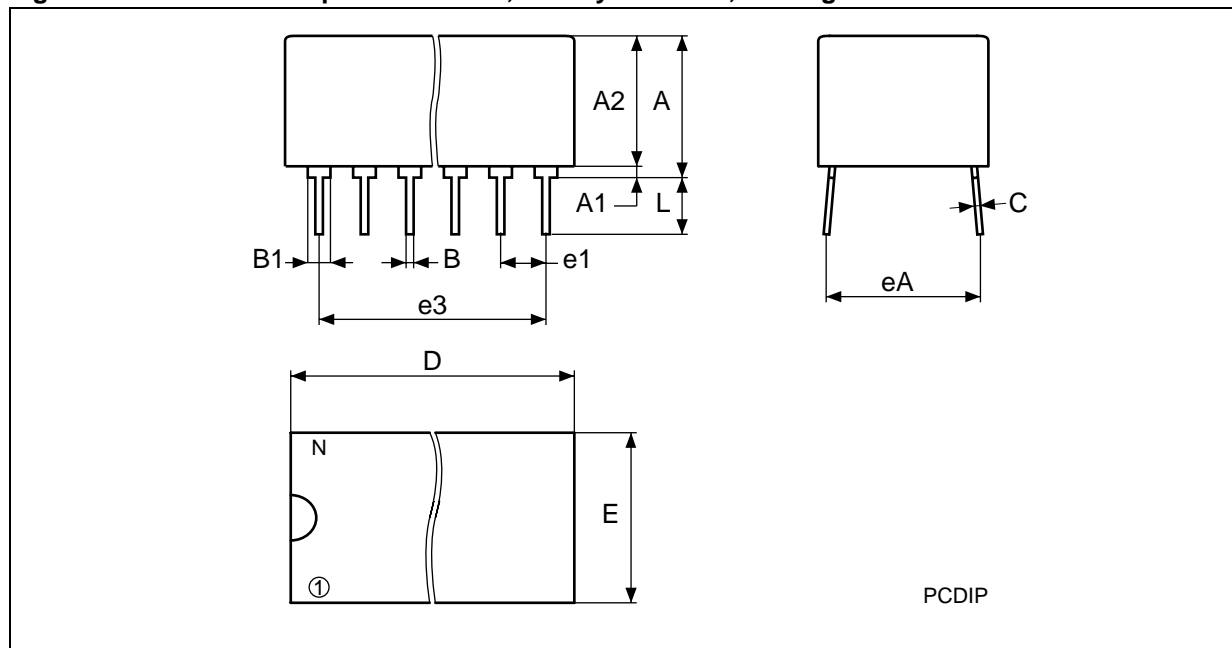

Note: Drawing is not to scale.

Table 11. PCDIP28 – 28-pin Plastic DIP, battery CAPHAT, Package Mechanical Data

Symb	mm			inches			
	Typ	Min	Max	Typ	Min	Max	
A		8.89	9.65		0.350	0.380	
A1		0.38	0.76		0.015	0.030	
A2		8.38	8.89		0.330	0.350	
B		0.38	0.53		0.015	0.021	
B1		1.14	1.78		0.045	0.070	
C		0.20	0.31		0.008	0.012	
D		39.37	39.88		1.550	1.570	
E		17.83	18.34		0.702	0.722	
e1		2.29	2.79		0.090	0.110	
e3		29.72	36.32		1.170	1.430	
eA		15.24	16.00		0.600	0.630	
L		3.05	3.81		0.120	0.150	
N		28			28		

## PART NUMBERING

**Table 12. Ordering Information Scheme**

Example:	M48Z	08	-100	PC	1	TR
<b>Device Type</b>	M48Z					
<b>Supply Voltage and Write Protect Voltage</b>	08 <sup>(1)</sup> = V <sub>CC</sub> = 4.75 to 5.5V; V <sub>PFD</sub> = 4.5 to 4.75V 18 = V <sub>CC</sub> = 4.5 to 5.5V; V <sub>PFD</sub> = 4.2 to 4.5V					
<b>Speed</b>	-100 = 100ns					
<b>Package</b>	PC = PCDIP28					
<b>Temperature Range</b>	1 = 0 to 70°C					
<b>Shipping Method</b>	blank = Tubes TR = Tape & Reel					

Note: 1. The M48Z08/18 part is offered with the PCDIP28 (e.g., CAPHAT™) package only.

For other options, or for more information on any aspect of this device, please contact the ST Sales Office nearest you.

## REVISION HISTORY

**Table 13. Document Revision History**

Date	Rev. #	Revision Details
March 1999	1.0	First issue
19-Jul-01	2.0	2-socket SOH and 2-pin SH packages removed; reformatted; temperature information added to tables (Table 4, 5, 7, 8, 9, 10)
19-Dec-01	2.1	Remove all references to “clock”
21-Dec-01	2.2	Changes to text to reflect addition of M48Z08Y option
20-May-02	2.3	Modify reflow time and temperature footnotes (Table 2)
10-Sep-02	2.4	Remove all references to “SNAPHAT” and M48Z08Y part (Figure 2; Table 2, 3, 7, 8, 10, 12)
01-Apr-03	3.0	v2.2 template applied; updated test condition (Table 10)
28-Aug-04	4.0	Reformatted; removed references to ‘crystal’ (Figure 1)

Information furnished is believed to be accurate and reliable. However, STMicroelectronics assumes no responsibility for the consequences of use of such information nor for any infringement of patents or other rights of third parties which may result from its use. No license is granted by implication or otherwise under any patent or patent rights of STMicroelectronics. Specifications mentioned in this publication are subject to change without notice. This publication supersedes and replaces all information previously supplied. STMicroelectronics products are not authorized for use as critical components in life support devices or systems without express written approval of STMicroelectronics.

The ST logo is a registered trademark of STMicroelectronics.

All other names are the property of their respective owners

© 2004 STMicroelectronics - All rights reserved

STMicroelectronics group of companies

Australia - Belgium - Brazil - Canada - China - Czech Republic - Finland - France - Germany - Hong Kong - India - Israel - Italy - Japan - Malaysia - Malta - Morocco - Singapore - Spain - Sweden - Switzerland - United Kingdom - United States of America

[www.st.com](http://www.st.com)