



M48Z128

M48Z128Y, M48Z128V*

5.0V OR 3.3V, 1 Mbit (128 Kbit x 8) ZEROPOWER® SRAM

FEATURES SUMMARY

- INTEGRATED, ULTRA LOW POWER SRAM, POWER-FAIL CONTROL CIRCUIT, AND BATTERY
- CONVENTIONAL SRAM OPERATION; UNLIMITED WRITE CYCLES
- 10 YEARS OF DATA RETENTION IN THE ABSENCE OF POWER
- BATTERY INTERNALLY ISOLATED UNTIL POWER IS FIRST APPLIED
- AUTOMATIC POWER-FAIL CHIP DESELECT and WRITE PROTECTION
- WRITE PROTECT VOLTAGES:
(V_{PFD} = Power-fail Deselect Voltage)
 - M48Z128: $V_{CC} = 4.75$ to $5.5V$
 $4.5V \leq V_{PFD} \leq 4.75V$
 - M48Z128Y: $V_{CC} = 4.5$ to $5.5V$
 $4.2V \leq V_{PFD} \leq 4.5V$
 - M48Z128V: $V_{CC} = 3.0$ to $3.6V$
 $2.8V \leq V_{PFD} \leq 3.0V$
- SOIC PACKAGE PROVIDES DIRECT CONNECTION FOR A SNAPHAT TOP WHICH CONTAINS THE BATTERY
- SNAPHAT HOUSING (BATTERY) IS REPLACEABLE
- PIN AND FUNCTION COMPATIBLE WITH JEDEC STANDARD 128K x 8 SRAMs
- EQUIVALENT SURFACE-MOUNT (SMT) SOLUTION REQUIRES A 28-PIN M40Z300/W and A STAND-ALONE 128K x8 LPSRAM (SNAPHAT® Top to be ordered separately)

Figure 1. 32-pin PMDIP Module

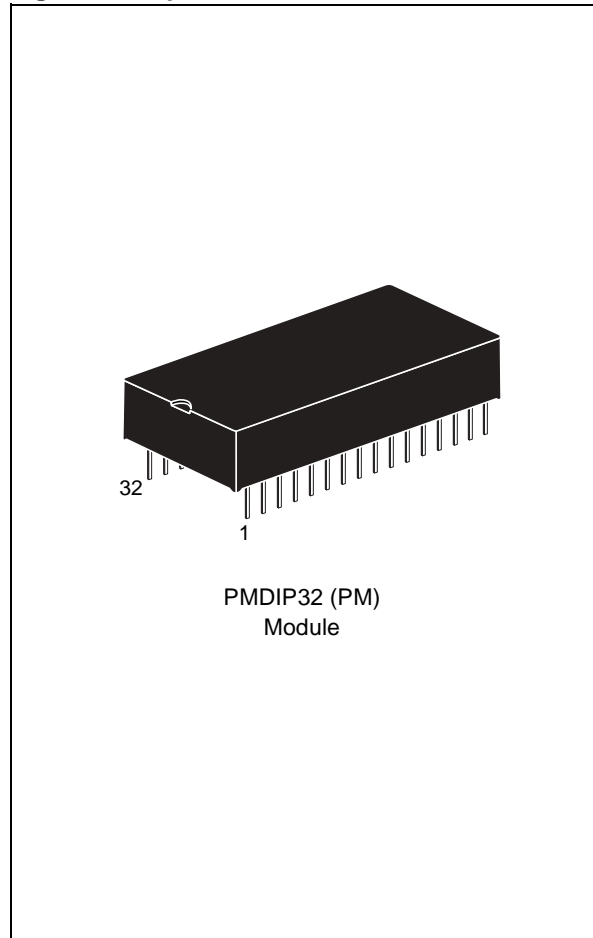

* Contact local ST sales office for availability.

TABLE OF CONTENTS

FEATURES SUMMARY	1
Figure 1. 32-pin PMDIP Module	1
DESCRIPTION	4
Figure 2. Logic Diagram	4
Table 1. Signal Names	4
Figure 3. DIP Connections	5
Figure 4. Block Diagram	5
Figure 5. Hardware Hookup for Equivalent Surface-Mount (SMT) Solution	6
Table 2. Equivalent Surface-Mount (SMT) Solution	6
OPERATING MODES	7
Table 3. Operating Modes	7
READ Mode	7
Figure 6. Chip Enable or Output Enable Controlled, READ Mode AC Waveforms	7
Figure 7. Address Controlled, READ Mode AC Waveforms	8
Table 4. READ Mode AC Characteristics	8
WRITE Mode	9
Figure 8. WRITE Enable Controlled, WRITE AC Waveforms	9
Figure 9. Chip Enable Controlled, WRITE AC Waveforms	9
Table 5. WRITE Mode AC Characteristics	10
Data Retention Mode	11
V_{CC} Noise And Negative Going Transients	11
Figure 10. Supply Voltage Protection	11
MAXIMUM RATING	12
Table 6. Absolute Maximum Ratings	12
DC AND AC PARAMETERS	12
Table 7. Operating and AC Measurement Conditions	12
Figure 11. AC Measurement Load Circuit	13
Table 8. Capacitance	13
Table 9. DC Characteristics	13
Figure 12. Power Down/Up Mode AC Waveforms	14
Table 10. Power Down/Up AC Characteristics	14
Table 11. Power Down/Up Trip Points DC Characteristics	14
PACKAGE MECHANICAL INFORMATION	15
Figure 13. PMDIP32 – 32-pin Plastic DIP Module, Package Outline	15
Table 12. PMDIP32 – 32-pin Plastic DIP Module, Package Mechanical Data	15
Figure 14. SOH28 – 28-lead Plastic Small Outline, battery SNAPHAT, Package Outline	16
Table 13. SOH28 – 28-lead Plastic Small Outline, battery SNAPHAT, Package Mechanical Data	16
Figure 15. SH – 4-pin SNAPHAT Housing for 48mAh Battery, Package Outline	17

Table 14. SH – 4-pin SNAPHAT Housing for 48mAh Battery, Package Mechanical Data 17
Figure 16.SH – 4-pin SNAPHAT Housing for 120mAh Battery, Package Outline. 18
Table 15. SH – 4-pin SNAPHAT Housing for 120mAh Battery, Package Mechanical Data 18

PART NUMBERING 19

Table 16. Ordering Information Scheme 19
Table 17. SNAPHAT Battery Table 19

REVISION HISTORY. 20

Table 18. Revision History. 20

DESCRIPTION

The M48Z128/Y/V ZEROPOWER[®] RAM is a 128 Kbit x 8 non-volatile static RAM organized as 131,072 words by 8 bits. The device combines an internal lithium battery, a CMOS SRAM and a control circuit in a plastic, 32-pin DIP module. This solution is available in two special packages to provide a highly integrated battery backed-up memory solution.

The M48Z128/Y/V is a non-volatile pin and function equivalent to any JEDEC standard 128K x 8 SRAM. It also easily fits into many ROM, EPROM, and EEPROM sockets, providing the non-volatility of PROMs without any requirement for special WRITE timing or limitations on the number of WRITES that can be performed. The 32-pin, 600mil DIP Module houses the M48Z128/Y/V silicon with a long life lithium button cell in a single package.

For surface-mount environments ST provides an equivalent SMT solution consisting of a 28-pin, 330mil SOIC NVRAM SUPERVISOR (M40Z300/

W) and a 32-pin, (TSOP, 8 x 20mm) 1Mb LPSRAM. Both 5V and 3V versions are available (see Table 2., page 6).

The 28-pin, 330mil SOIC provides sockets with gold plated contacts at both ends for direct connection to a separate SNAPHAT[®] housing containing the battery.

The unique design allows the SNAPHAT battery package to be mounted on top of the SOIC package after the completion of the surface-mount process. Insertion of the SNAPHAT housing after reflow prevents potential battery damage due to the high temperatures required for device surface-mounting. The SNAPHAT housing is keyed to prevent reverse insertion.

The SNAPHAT battery package is shipped separately in plastic anti-static tubes or in Tape & Reel form. The part number is "M4Zxx-BR00SH" (see Table 17., page 19).

Figure 2. Logic Diagram

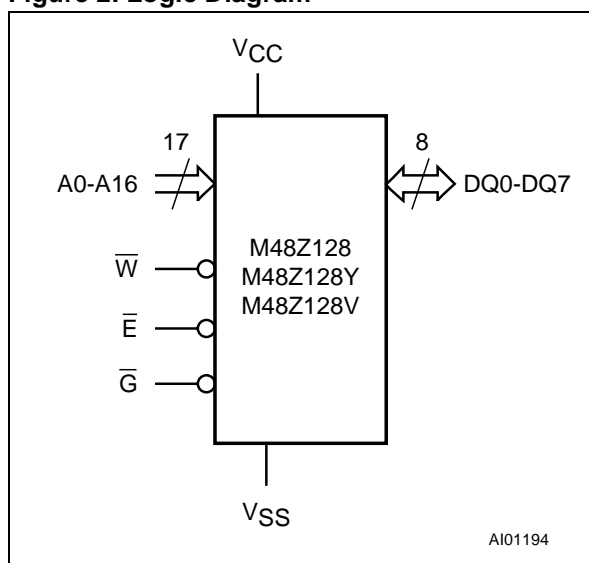

Table 1. Signal Names

A0-A16	Address Inputs
DQ0-DQ7	Data Inputs / Outputs
\bar{E}	Chip Enable Input
\bar{G}	Output Enable Input
\bar{W}	WRITE Enable Input
V _{CC}	Supply Voltage
V _{SS}	Ground
NC	Not Connected Internally

Figure 3. DIP Connections

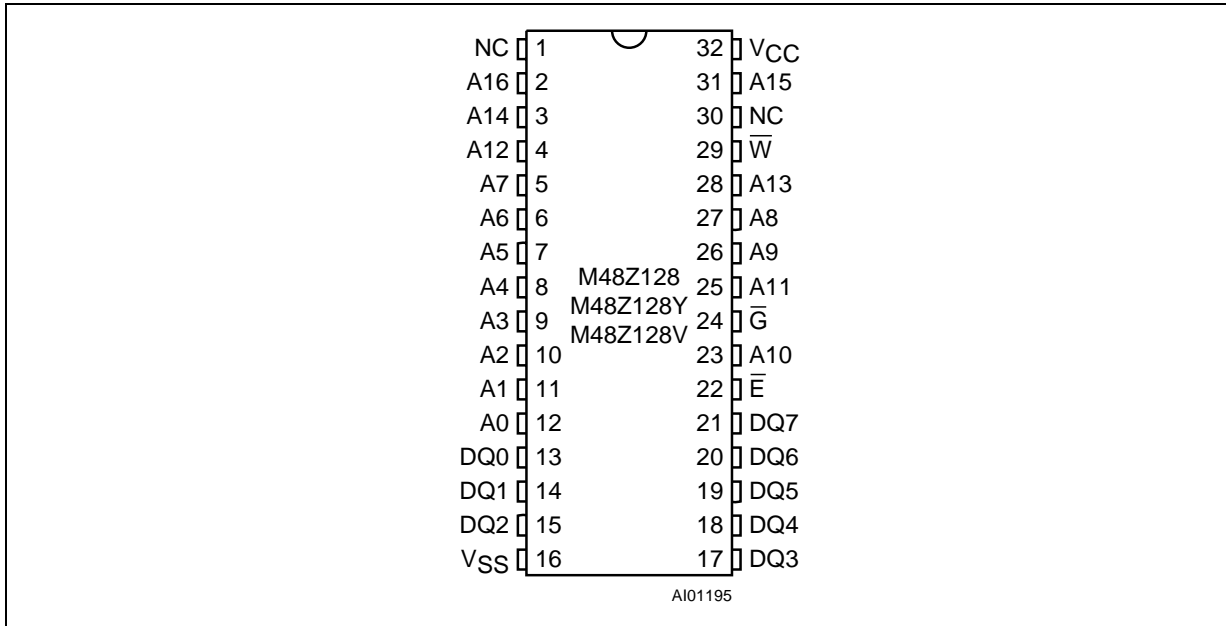

Figure 4. Block Diagram

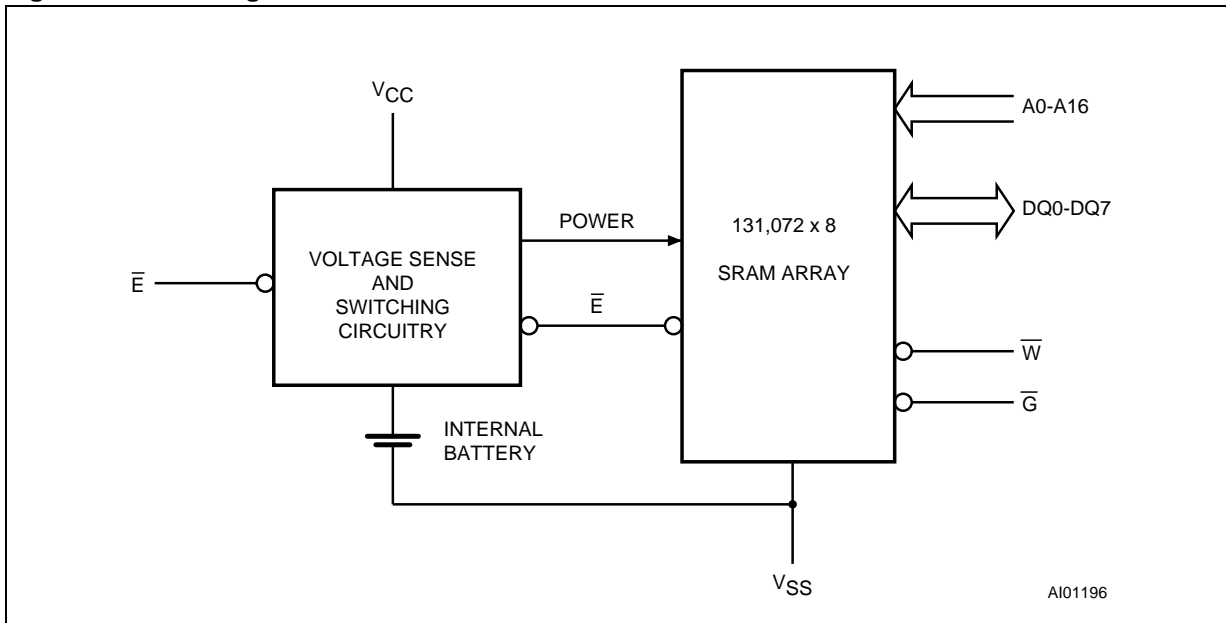
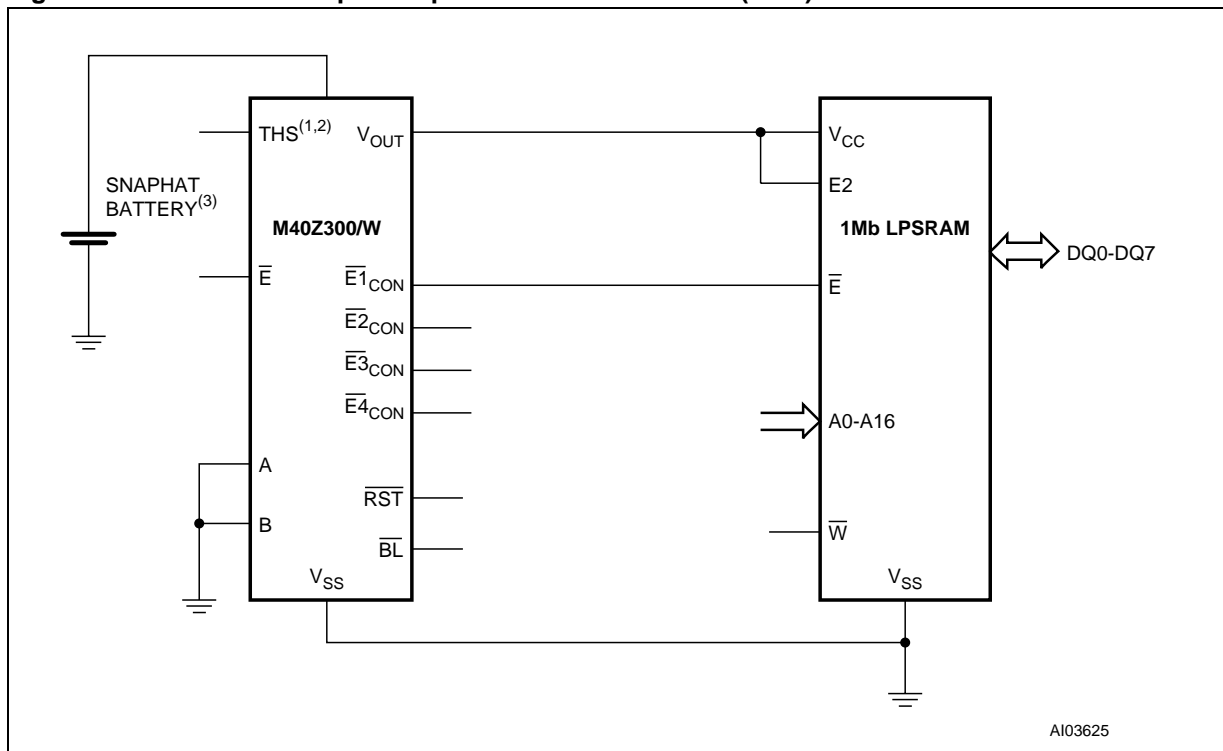

Figure 5. Hardware Hookup for Equivalent Surface-Mount (SMT) Solution



Note: For pin connections, see individual data sheet for M48Z300/300W at www.st.com.

1. Connect THS pin to V_{OUT} if $4.2V \leq V_{PFD} \leq 4.5V$ (M48Z128Y) or connect THS pin to V_{SS} if $4.5V \leq V_{PFD} \leq 4.75V$ (M48Z128).
2. Connect THS pin to V_{SS} if $2.8V \leq V_{PFD} \leq 3.0V$ (M48Z128V).
3. SNAPHAT® Top ordered separately.

Table 2. Equivalent Surface-Mount (SMT) Solution

NVRAM	LPSRAM	SUPERVISOR	THS Pin ⁽¹⁾
M48Z128	5V 1Mb LPSRAM	M40Z300	V_{SS}
M48Z128Y	5V 1Mb LPSRAM	M40Z300	V_{OUT}
M48Z128V	3V 1Mb LPSRAM	M40Z300W	V_{SS}

Note: 1. Connection of Threshold Select Pin (Pin 13) of SUPERVISOR (M40Z300/300W).

OPERATING MODES

The M48Z128/Y/V also has its own Power-fail Detect circuit. The control circuitry constantly monitors the single V_{CC} supply for an out of tolerance condition. When V_{CC} is out of tolerance, the circuit write protects the SRAM, providing a high degree

of data security in the midst of unpredictable system operation brought on by low V_{CC} . As V_{CC} falls below the switchover voltage (V_{SO}), the control circuitry connects the battery which maintains data until valid power returns.

Table 3. Operating Modes

Mode	V_{CC}	\bar{E}	\bar{G}	\bar{W}	DQ0-DQ7	Power
Deselect	4.75 to 5.5V or 4.5 to 5.5V or 3.0 to 3.6V	V_{IH}	X	X	High Z	Standby
WRITE		V_{IL}	X	V_{IL}	D_{IN}	Active
READ		V_{IL}	V_{IL}	V_{IH}	D_{OUT}	Active
READ		V_{IL}	V_{IH}	V_{IH}	High Z	Active
Deselect	V_{SO} to V_{PFD} (min) ⁽¹⁾	X	X	X	High Z	CMOS Standby
Deselect	$\leq V_{SO}$ ⁽¹⁾	X	X	X	High Z	Battery Back-up Mode

Note: X = V_{IH} or V_{IL} ; V_{SO} = Battery Back-up Switchover Voltage.
1. See Table 11., page 14 for details.

READ Mode

The M48Z128/Y/V is in the READ Mode whenever \bar{W} (WRITE Enable) is high and \bar{E} (Chip Enable) is low. The device architecture allows ripple-through access of data from eight of 1,048,576 locations in the static storage array. Thus, the unique address specified by the 17 address inputs defines which one of the 131,072 bytes of data is to be accessed. Valid data will be available at the Data I/O pins within Address Access time (t_{AVQV}) after the last address input signal is stable, providing that the \bar{E} and \bar{G} (Output Enable) access times are also sat-

isfied. If the \bar{E} and \bar{G} access times are not met, valid data will be available after the later of Chip Enable Access time (t_{ELQV}) or Output Enable Access Time (t_{GLQV}). The state of the eight three-state Data I/O signals is controlled by \bar{E} and \bar{G} . If the outputs are activated before t_{AVQV} , the data lines will be driven to an indeterminate state until t_{AVQV} . If the address inputs are changed while \bar{E} and \bar{G} remain low, output data will remain valid for Output Data Hold time (t_{AXQX}) but will go indeterminate until the next Address Access.

Figure 6. Chip Enable or Output Enable Controlled, READ Mode AC Waveforms

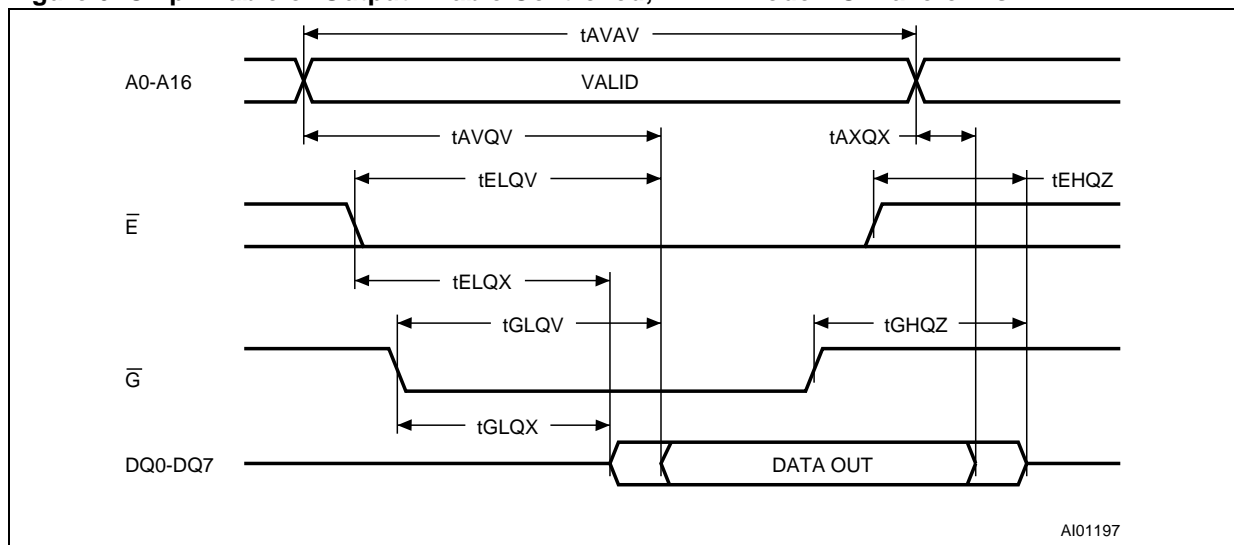

Note: WRITE Enable (\bar{W}) = High.

M48Z128, M48Z128Y, M48Z128V*

Figure 7. Address Controlled, READ Mode AC Waveforms

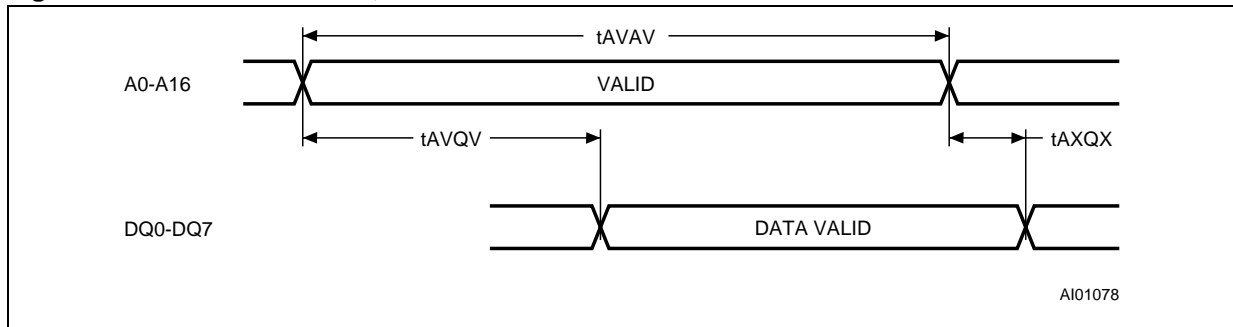

Note: Chip Enable (\bar{E}) and Output Enable (\bar{G}) = Low, WRITE Enable (\bar{W}) = High.

Table 4. READ Mode AC Characteristics

Symbol	Parameter ⁽¹⁾	M48Z128/Y		M48Z128/Y/V		M48Z128/Y/V		Unit
		-70		-85		-120		
		Min	Max	Min	Max	Min	Max	
t_{AVAV}	READ Cycle Time	70		85		120		ns
t_{AVQV}	Address Valid to Output Valid		70		85		120	ns
t_{ELQV}	Chip Enable Low to Output Valid		70		85		120	ns
t_{GLQV}	Output Enable Low to Output Valid		35		45		60	ns
$t_{ELQX}^{(2)}$	Chip Enable Low to Output Transition	5		5		5		ns
$t_{GLQX}^{(2)}$	Output Enable Low to Output Transition	3		3		3		ns
$t_{EHQZ}^{(2)}$	Chip Enable High to Output Hi-Z		30		35		45	ns
$t_{GHQZ}^{(2)}$	Output Enable High to Output Hi-Z		20		25		35	ns
t_{AXQX}	Address Transition to Output Transition	5		5		10		ns

Note: 1. Valid for Ambient Operating Temperature: $T_A = 0$ to 70°C ; $V_{CC} = 4.75$ to 5.5V , 4.5 to 5.5V , or 3.0 to 3.6V (except where noted).

2. $C_L = 5\text{pF}$.

WRITE Mode

The M48Z128/Y/V is in the WRITE Mode whenever \overline{W} and \overline{E} are active. The start of a WRITE is referenced from the latter occurring falling edge of \overline{W} or \overline{E} . A WRITE is terminated by the earlier rising edge of \overline{W} or \overline{E} .

The addresses must be held valid throughout the cycle. \overline{E} or \overline{W} must return high for minimum of t_{EHAX} from \overline{E} or t_{WHAX} from \overline{W} prior to the initiation

of another READ or WRITE cycle. Data-in must be valid t_{DVWH} prior to the end of WRITE and remain valid for t_{WHDX} or t_{EHDX} afterward. \overline{G} should be kept high during WRITE cycles to avoid bus contention; although, if the output bus has been activated by a low on \overline{E} and \overline{G} , a low on \overline{W} will disable the outputs t_{WLQZ} after \overline{W} falls.

Figure 8. WRITE Enable Controlled, WRITE AC Waveforms

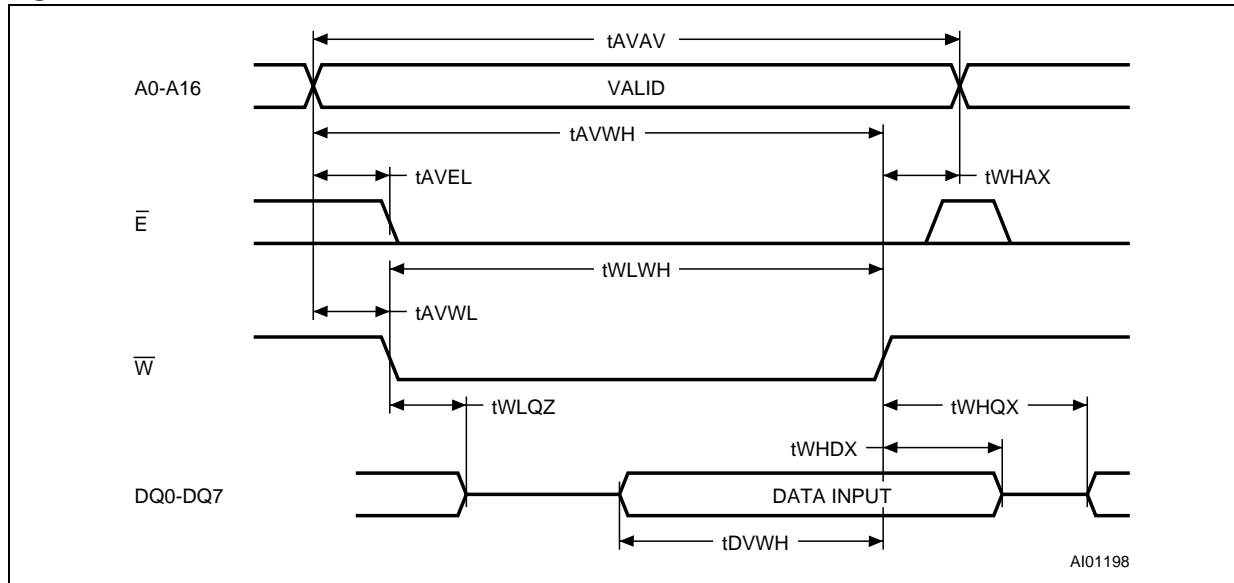

Note: Output Enable (\overline{G}) = High.

Figure 9. Chip Enable Controlled, WRITE AC Waveforms

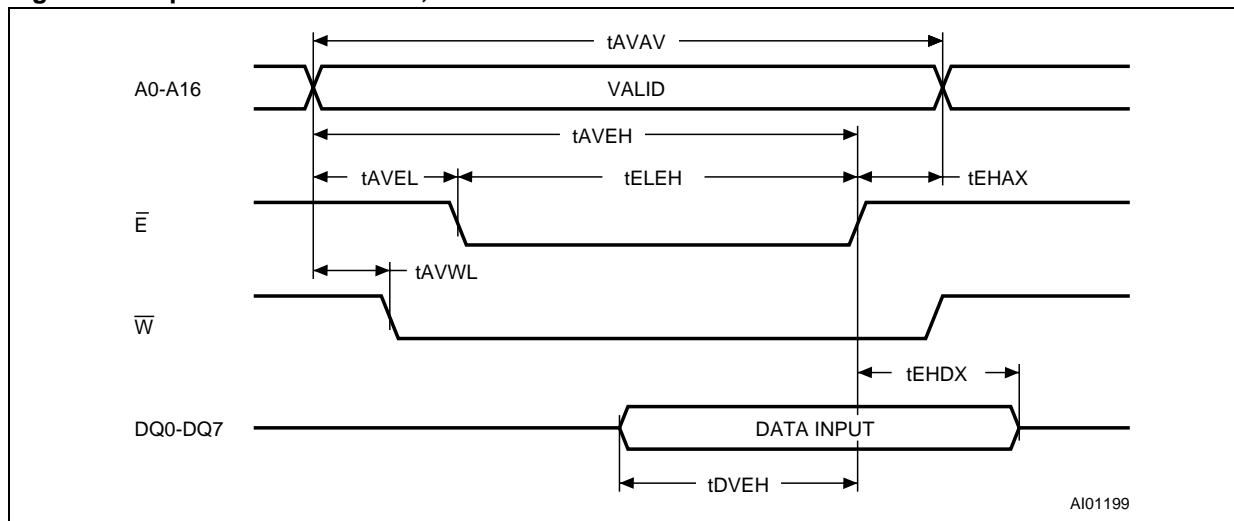

Note: Output Enable (\overline{G}) = High.

Table 5. WRITE Mode AC Characteristics

Symbol	Parameter ⁽¹⁾	M48Z128/Y		M48Z128/Y/V		M48Z128/Y/V		Unit
		-70		-85		-120		
		Min	Max	Min	Max	Min	Max	
t _{AVAV}	WRITE Cycle Time	70		85		120		ns
t _{AVWL}	Address Valid to WRITE Enable Low	0		0		0		ns
t _{AVEL}	Address Valid to Chip Enable Low	0		0		0		ns
t _{WLWH}	WRITE Enable Pulse Width	55		65		85		ns
t _{ELEH}	Chip Enable Low to Chip Enable High	55		75		100		ns
t _{WHAX}	WRITE Enable High to Address Transition	5		5		5		ns
t _{EHAX}	Chip Enable High to Address Transition	15		15		15		ns
t _{DVWH}	Input Valid to WRITE Enable High	30		35		45		ns
t _{DVEH}	Input Valid to Chip Enable High	30		35		45		ns
t _{WHDX}	WRITE Enable High to Input Transition	0		0		0		ns
t _{EHDx}	Chip Enable High to Input Transition	10		10		10		ns
t _{WLQZ} ^(2,3)	WRITE Enable Low to Output Hi-Z		25		30		40	ns
t _{AVWH}	Address Valid to WRITE Enable High	65		75		100		ns
t _{AVEH}	Address Valid to Chip Enable High	65		75		100		ns
t _{WHQX} ^(2,3)	WRITE Enable High to Output Transition	5		5		5		ns

Note: 1. Valid for Ambient Operating Temperature: T_A = 0 to 70°C; V_{CC} = 4.75 to 5.5V, 4.5 to 5.5V or 3.0 to 3.6V (except where noted).

2. C_L = 5pF.

3. If \bar{E} goes low simultaneously with \bar{W} going low, the outputs remain in the high impedance state.

Data Retention Mode

With valid V_{CC} applied, the M48Z128/Y/V operates as a conventional BYTEWIDE™ static RAM. Should the supply voltage decay, the RAM will automatically power-fail deselect, write protecting itself t_{WP} after V_{CC} falls below V_{PFD} . All outputs become high impedance, and all inputs are treated as “Don't care.”

If power fail detection occurs during a valid access, the memory cycle continues to completion. If the memory cycle fails to terminate within the time t_{WP} , write protection takes place. When V_{CC} drops below V_{SO} , the control circuit switches power to the internal energy source which preserves data.

The internal coin cell will maintain data in the M48Z128/Y/V after the initial application of V_{CC} for an accumulated period of at least 10 years when V_{CC} is less than V_{SO} . As system power returns and V_{CC} rises above V_{SO} , the battery is disconnected, and the power supply is switched to external V_{CC} . Write protection continues for t_{ER} after V_{CC} reaches V_{PFD} to allow for processor stabilization. After t_{ER} , normal RAM operation can resume.

For more information on Battery Storage Life refer to the Application Note AN1012.

V_{CC} Noise And Negative Going Transients

I_{CC} transients, including those produced by output switching, can produce voltage fluctuations, resulting in spikes on the V_{CC} bus. These transients can be reduced if capacitors are used to store energy which stabilizes the V_{CC} bus. The energy stored in the bypass capacitors will be released as low going spikes are generated or energy will be absorbed when overshoots occur. A ceramic bypass capacitor value of $0.1\mu\text{F}$ (see Figure 10.) is recommended in order to provide the needed filtering.

In addition to transients that are caused by normal SRAM operation, power cycling can generate negative voltage spikes on V_{CC} that drive it to values below V_{SS} by as much as one volt. These negative spikes can cause data corruption in the SRAM while in battery backup mode. To protect from these voltage spikes, ST recommends connecting a schottky diode from V_{CC} to V_{SS} (cathode connected to V_{CC} , anode to V_{SS}). (Schottky diode 1N5817 is recommended for through hole and MBRS120T3 is recommended for surface-mount).

Figure 10. Supply Voltage Protection

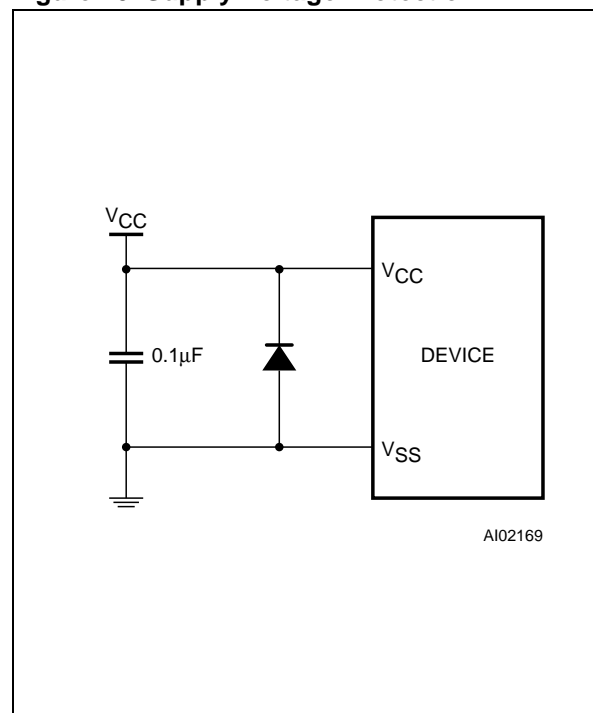

MAXIMUM RATING

Stressing the device above the rating listed in the “Absolute Maximum Ratings” table may cause permanent damage to the device. These are stress ratings only and operation of the device at these or any other conditions above those indicated in the Operating sections of this specification is

not implied. Exposure to Absolute Maximum Rating conditions for extended periods may affect device reliability. Refer also to the STMicroelectronics SURE Program and other relevant quality documents.

Table 6. Absolute Maximum Ratings

Symbol	Parameter	Value	Unit	
T _A	Ambient Operating Temperature	0 to 70	°C	
T _{STG}	Storage Temperature (V _{CC} Off, Oscillator Off)	-40 to 85	°C	
T _{BIAS}	Temperature Under Bias	-10 to 70	°C	
T _{SLD} ^(1,2,3)	Lead Solder Temperature for 10 seconds	260	°C	
V _{IO}	Input or Output Voltages	-0.3 to 7	V	
V _{CC}	Supply Voltage	M48Z128/Y	-0.3 to 7.0	V
		M48Z128V	-0.3 to 4.6	V
I _O	Output Current	20	mA	
P _D	Power Dissipation	1	W	

Note: 1. For DIP package: Soldering temperature not to exceed 260°C for 10 seconds (total thermal budget not to exceed 150°C for longer than 30 seconds). No preheat above 150°C, or direct exposure to IR reflow (or IR preheat) allowed, to avoid damaging the Lithium battery.
 2. For SO package, standard (SnPb) lead finish: Reflow at peak temperature of 225°C (total thermal budget not to exceed 180°C for between 90 to 150 seconds).
 3. For SO package, Lead-free (Pb-free) lead finish: Reflow at peak temperature of 260°C (total thermal budget not to exceed 245°C for greater than 30 seconds).

CAUTION: Negative undershoots below -0.3V are not allowed on any pin while in the Battery Back-up mode.
CAUTION: Do NOT wave solder SOIC to avoid damaging SNAPHAT sockets.

DC AND AC PARAMETERS

This section summarizes the operating and measurement conditions, as well as the DC and AC characteristics of the device. The parameters in the following DC and AC Characteristic tables are derived from tests performed under the Measure-

ment Conditions listed in the relevant tables. Designers should check that the operating conditions in their projects match the measurement conditions when using the quoted parameters.

Table 7. Operating and AC Measurement Conditions

Parameter	M48Z128/Y	M48Z128V	Unit
Supply Voltage (V _{CC})	4.75 to 5.5V or 4.5 to 5.5	3.0 to 3.6	V
Ambient Operating Temperature (T _A)	0 to 70	0 to 70	°C
Load Capacitance (C _L)	100	50	pF
Input Rise and Fall Times	≤ 5	≤ 5	ns
Input Pulse Voltages	0 to 3	0 to 3	V
Input and Output Timing Ref. Voltages	1.5	1.5	V

Note: Output Hi-Z is defined as the point where data is no longer driven.

Figure 11. AC Measurement Load Circuit

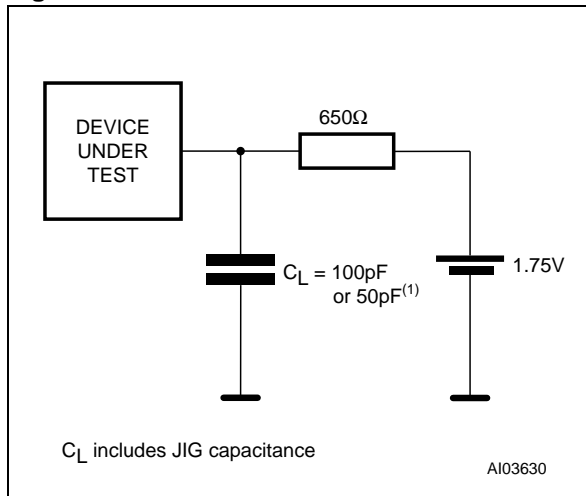

Note: 1. 50pF for M48Z128V (3.3V).

Table 8. Capacitance

Symbol	Parameter ^(1,2)	Min	Max	Unit
C_{IN}	Input Capacitance		10	pF
$C_{IO}^{(3)}$	Input / Output Capacitance		10	pF

Note: 1. Effective capacitance measured with power supply at 5V (M48Z128/Y) or 3.3V (M48Z128V); sampled only, not 100% tested.
 2. At 25°C, $f = 1\text{MHz}$.
 3. Outputs deselected.

Table 9. DC Characteristics

Sym	Parameter	Test Condition ⁽¹⁾	M48Z128/Y		M48Z128V		Unit
			-70 / -85 / -120		-85 / -120		
			Min	Max	Min	Max	
I_{LI}	Input Leakage Current	$0V \leq V_{IN} \leq V_{CC}$		± 1		± 1	μA
$I_{LO}^{(2)}$	Output Leakage Current	$0V \leq V_{OUT} \leq V_{CC}$		± 1		± 1	μA
I_{CC}	Supply Current	$\bar{E} = V_{IL}$ Outputs open		105		50	mA
I_{CC1}	Supply Current (Standby) TTL	$\bar{E} = V_{IH}$		7		4	mA
I_{CC2}	Supply Current (Standby) CMOS	$\bar{E} = V_{CC} - 0.2V$		4		3	mA
V_{IL}	Input Low Voltage		-0.3	0.8	-0.3	0.6	V
V_{IH}	Input High Voltage		2.2	$V_{CC} + 0.3$	2.2	$V_{CC} + 0.3$	V
V_{OL}	Output Low Voltage	$I_{OL} = 2.1\text{mA}$		0.4		0.4	V
V_{OH}	Output High Voltage	$I_{OH} = -1\text{mA}$	2.4		2.2		V

Note: 1. Valid for Ambient Operating Temperature: $T_A = 0$ to 70°C ; $V_{CC} = 4.75$ to $5.5V$, 4.5 to $5.5V$, or 3.0 to $3.6V$ (except where noted).
 2. Outputs deselected.

Figure 12. Power Down/Up Mode AC Waveforms

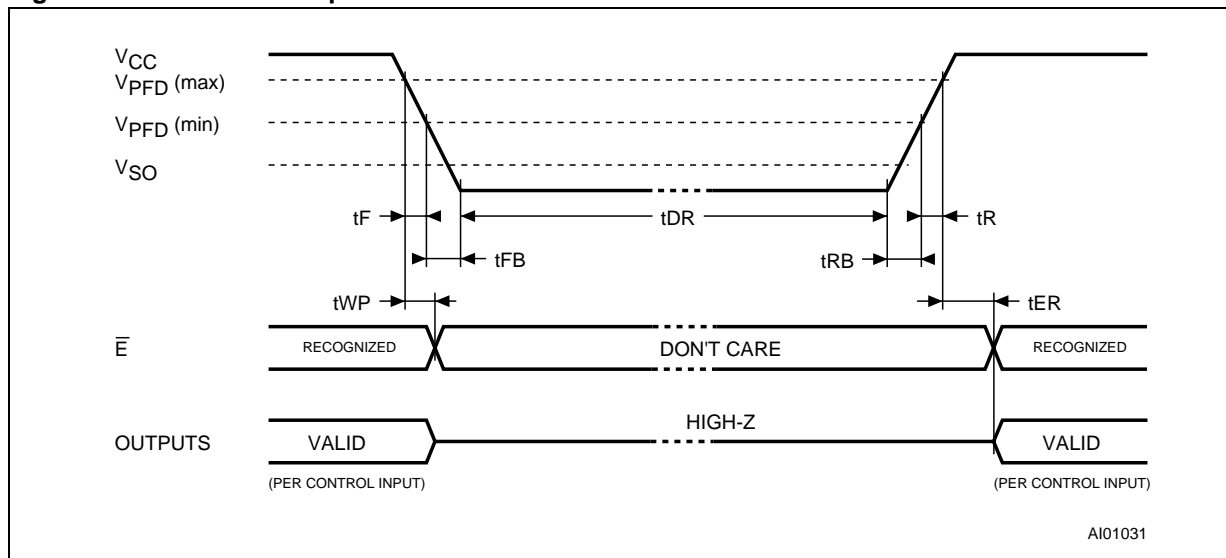

Table 10. Power Down/Up AC Characteristics

Symbol	Parameter ⁽¹⁾	Min	Max	Unit	
t _F ⁽²⁾	V _{PFD} (max) to V _{PFD} (min) V _{CC} Fall Time	300		μs	
t _{FB} ⁽³⁾	V _{PFD} (min) to V _{SS} V _{CC} Fall Time	M48Z128/Y	10	μs	
		M48Z128V	150		
t _R	V _{PFD} (min) to V _{PFD} (max) V _{CC} Rise Time	10		μs	
t _{RB}	V _{SS} to V _{PFD} (min) V _{CC} Rise Time	1		μs	
t _{WP}	Write Protect Time	M48Z128/Y	40	150	μs
		M48Z128V	40	250	
t _{ER}	E-bar Recovery Time	40	120	ms	

Note: 1. Valid for Ambient Operating Temperature: T_A = 0 to 70°C; V_{CC} = 4.75 to 5.5V, 4.5 to 5.5V, or 3.0 to 3.6V (except where noted).
 2. V_{PFD} (max) to V_{PFD} (min) fall time of less than t_F may result in deselection/write protection not occurring until 200μs after V_{CC} passes V_{PFD} (min).
 3. V_{PFD} (min) to V_{SS} fall time of less than t_{FB} may cause corruption of RAM data.

Table 11. Power Down/Up Trip Points DC Characteristics

Symbol	Parameter ^(1,2)	Min	Typ	Max	Unit	
V _{PFD}	Power-fail Deselect Voltage	M48Z128	4.5	4.6	4.75	V
		M48Z128Y	4.2	4.3	4.5	V
		M48Z128V	2.8	2.9	3.0	V
V _{SO}	Battery Back-up Switchover Voltage	M48Z128/Y		3.0		V
		M48Z128V		2.5		V
t _{DR} ⁽³⁾	Expected Data Retention Time	10			YEARS	

Note: 1. All voltages referenced to V_{SS}.
 2. Valid for Ambient Operating Temperature: T_A = 0 to 70°C; V_{CC} = 4.75 to 5.5V, 4.5 to 5.5V, or 3.0 to 3.6V (except where noted).
 3. At 25°C; V_{CC} = 0V.

PACKAGE MECHANICAL INFORMATION

Figure 13. PMDIP32 – 32-pin Plastic DIP Module, Package Outline

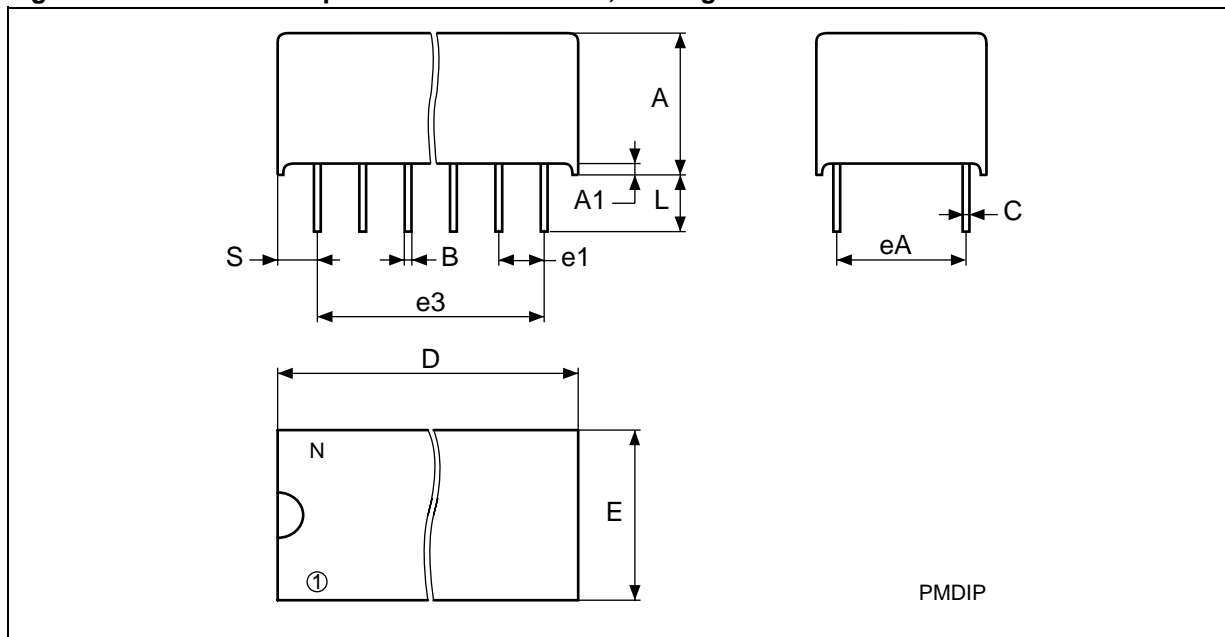

Note: Drawing is not to scale.

Table 12. PMDIP32 – 32-pin Plastic DIP Module, Package Mechanical Data

Symb	mm			inches		
	Typ	Min	Max	Typ	Min	Max
A		9.27	9.52		0.365	0.375
A1		0.38	–		0.015	–
B		0.43	0.59		0.017	0.023
C		0.20	0.33		0.008	0.013
D		42.42	43.18		1.670	1.700
E		18.03	18.80		0.710	0.740
e1		2.29	2.79		0.090	0.110
e3		34.29	41.91		1.350	1.650
eA		14.99	16.00		0.590	0.630
L		3.05	3.81		0.120	0.150
S		1.91	2.79		0.075	0.110
N		32			32	

Figure 14. SOH28 – 28-lead Plastic Small Outline, battery SNAPHAT, Package Outline

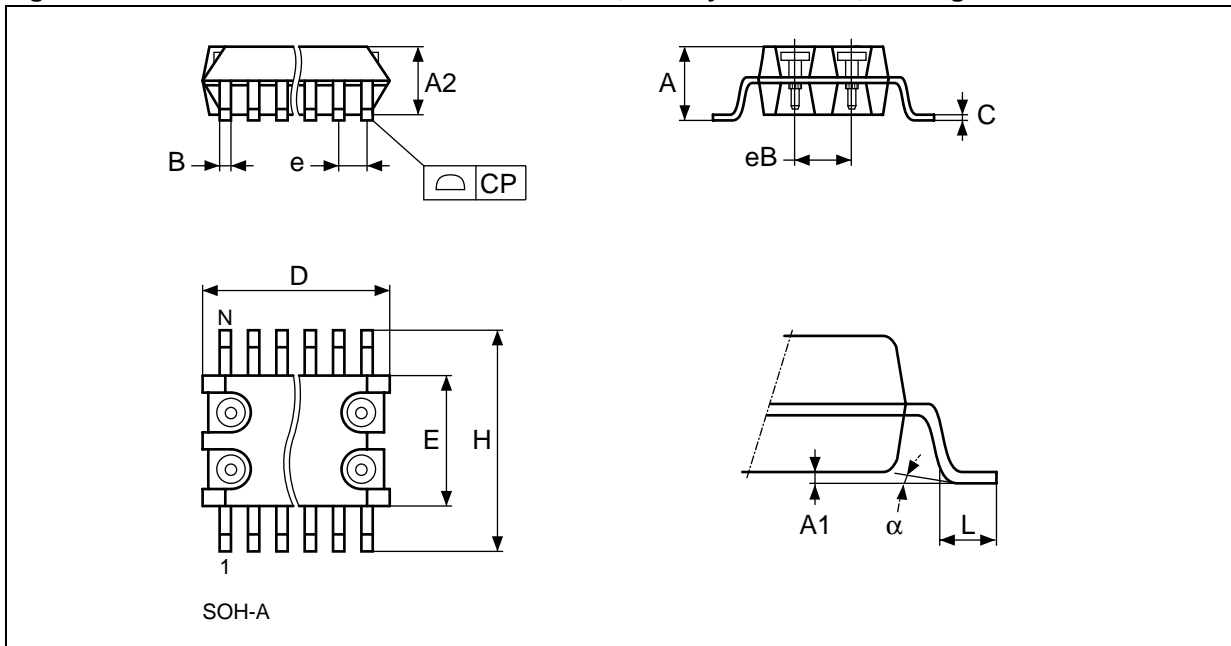

Note: Drawing is not to scale.

Table 13. SOH28 – 28-lead Plastic Small Outline, battery SNAPHAT, Package Mechanical Data

Symbol	mm			inch		
	Typ	Min	Max	Typ	Min	Max
A			3.05			0.120
A1		0.05	0.36		0.002	0.014
A2		2.34	2.69		0.092	0.106
B		0.36	0.51		0.014	0.020
C		0.15	0.32		0.006	0.012
D		17.71	18.49		0.697	0.728
E		8.23	8.89		0.324	0.350
e	1.27	–	–	0.050	–	–
eB		3.20	3.61		0.126	0.142
H		11.51	12.70		0.453	0.500
L		0.41	1.27		0.016	0.050
alpha		0°	8°		0°	8°
N	28			28		
CP			0.10			0.004

Figure 15. SH – 4-pin SNAPHAT Housing for 48mAh Battery, Package Outline

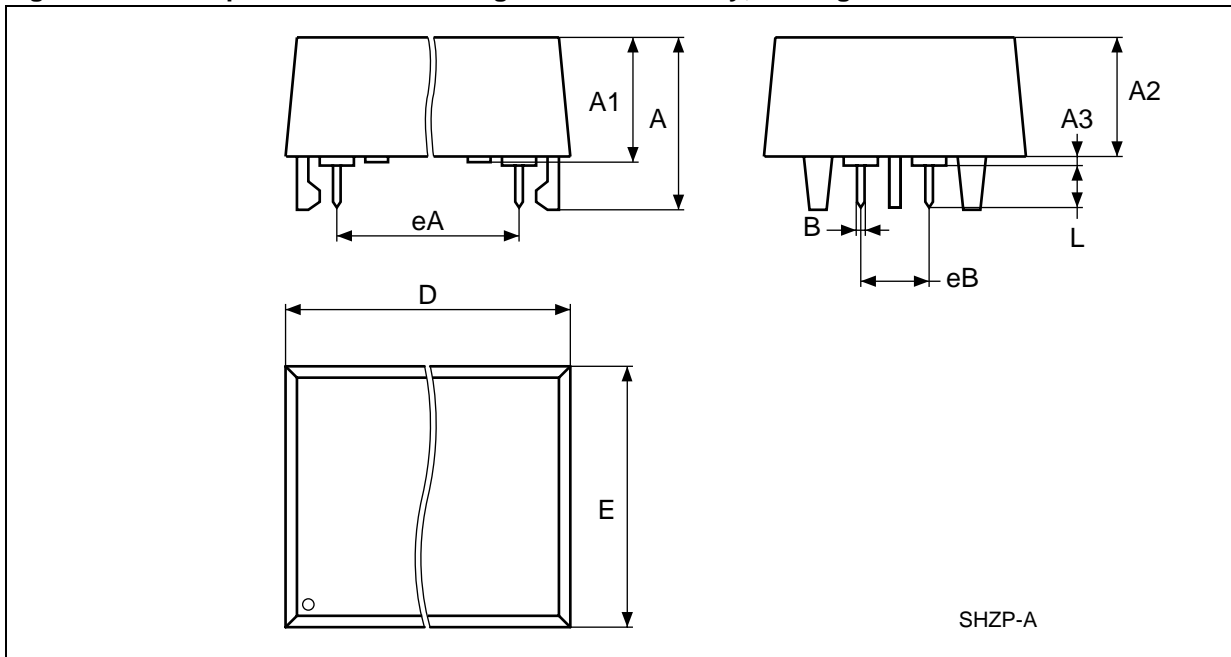

Note: Drawing is not to scale.

Table 14. SH – 4-pin SNAPHAT Housing for 48mAh Battery, Package Mechanical Data

Symb	mm			inches		
	Typ	Min	Max	Typ	Min	Max
A			9.78			0.385
A1		6.73	7.24		0.265	0.285
A2		6.48	6.99		0.255	0.275
A3			0.38			0.015
B		0.46	0.56		0.018	0.022
D		21.21	21.84		0.835	0.860
E		14.22	14.99		0.560	0.590
eA		15.55	15.95		0.612	0.628
eB		3.20	3.61		0.126	0.142
L		2.03	2.29		0.080	0.090

Figure 16. SH – 4-pin SNAPHAT Housing for 120mAh Battery, Package Outline

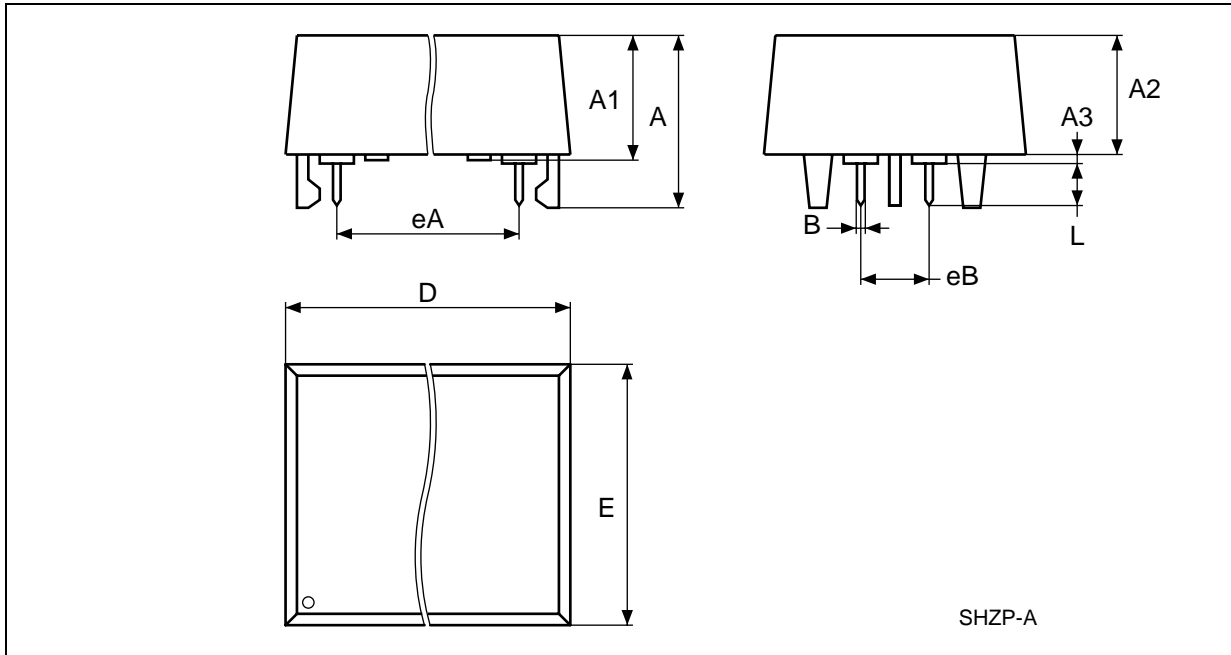

Note: Drawing is not to scale.

Table 15. SH – 4-pin SNAPHAT Housing for 120mAh Battery, Package Mechanical Data

Symb	mm			inches		
	Typ	Min	Max	Typ	Min	Max
A			10.54			0.415
A1		8.00	8.51		0.315	0.335
A2		7.24	8.00		0.285	0.315
A3			0.38			0.015
B		0.46	0.56		0.018	0.022
D		21.21	21.84		0.835	0.860
E		17.27	18.03		0.680	0.710
eA		15.55	15.95		0.612	0.628
eB		3.20	3.61		0.126	0.142
L		2.03	2.29		0.080	0.090

PART NUMBERING

Table 16. Ordering Information Scheme

Example:	M48Z	128Y	-70	PM	1
Device Type					
M48Z					
Supply Voltage and Write Protect Voltage					
128 = $V_{CC} = 4.75$ to $5.5V$; $V_{PFD} = 4.5$ to $4.75V$					
128Y = $V_{CC} = 4.5$ to $5.5V$; $V_{PFD} = 4.2$ to $4.5V$					
128V ⁽¹⁾ = $V_{CC} = 3.0$ to $3.6V$; $V_{PFD} = 2.8$ to $3.0V$					
Speed					
-70 = 70ns (for M48Z128/Y)					
-85 = 85ns (for M48Z128/Y/V)					
-120 = 120ns (for M48Z128/Y/V)					
Package⁽²⁾					
PM = PMDIP32					
Temperature Range					
1 = 0 to 70°C					

Note: 1. Contact Local Sales Office

2. The SOIC package (SOH28) requires the battery package (SNAPHAT[®]) which is ordered separately under the part number "M4Zxx-BR00SH" in plastic tube or "M4Zxx-BR00SHTR" in Tape & Reel form.

3. **Caution:** Do not place the SNAPHAT battery package "M4Zxx-BR00SH" in conductive foam as it will drain the lithium button-cell battery.

For other options, or for more information on any aspect of this device, please contact the ST Sales Office nearest you.

Table 17. SNAPHAT Battery Table

Part Number	Description	Package
M4Z28-BR00SH	Lithium Battery (48mAh) SNAPHAT	SH
M4Z32-BR00SH	Lithium Battery (120mAh) SNAPHAT	SH

REVISION HISTORY**Table 18. Revision History**

Date	Version	Revision Details
May 1999	1.0	First Issue
13-Apr-00	2.0	Document Layout changed; surface-Mount Chip Set solution added
20-Jun-00	2.1	t _{GLQX} changed (Table 4)
19-Jul-00	2.2	M48Z128V added
14-Sep-01	3.0	Reformatted; added temperature information (Table 8, 9, 4, 5, 10, 11)
07-Nov-01	3.1	Remove chipset option from Ordering Information (Table 16)
20-May-02	3.2	Modify reflow time and temperature footnotes (Table 6)
18-Nov-02	3.3	Modifying SMT solution text (Figure 2, 5; Table 2)
17-Sep-03	3.4	Remove references to M68ZXXX (obsolete) parts (Figure 5; Table 2); update disclaimer
22-Feb-05	4.0	Reformatted; IR reflow, SO package updates (Table 6)

Information furnished is believed to be accurate and reliable. However, STMicroelectronics assumes no responsibility for the consequences of use of such information nor for any infringement of patents or other rights of third parties which may result from its use. No license is granted by implication or otherwise under any patent or patent rights of STMicroelectronics. Specifications mentioned in this publication are subject to change without notice. This publication supersedes and replaces all information previously supplied. STMicroelectronics products are not authorized for use as critical components in life support devices or systems without express written approval of STMicroelectronics.

The ST logo is a registered trademark of STMicroelectronics.

All other names are the property of their respective owners

© 2005 STMicroelectronics - All rights reserved

STMicroelectronics group of companies
Australia - Belgium - Brazil - Canada - China - Czech Republic - Finland - France - Germany - Hong Kong - India - Israel - Italy - Japan -
Malaysia - Malta - Morocco - Singapore - Spain - Sweden - Switzerland - United Kingdom - United States of America
www.st.com