

## 5V or 3.3V, 16 Mbit (2Mb x 8) ZEROPOWER<sup>®</sup> SRAM

### FEATURES SUMMARY

- INTEGRATED, ULTRA LOW POWER SRAM, POWER-FAIL CONTROL CIRCUIT, and BATTERIES
- CONVENTIONAL SRAM OPERATION; UNLIMITED WRITE CYCLES
- 10 YEARS OF DATA RETENTION IN THE ABSENCE OF POWER
- AUTOMATIC POWER-FAIL CHIP DESELECT and WRITE PROTECTION
- WRITE PROTECT VOLTAGES ( $V_{PFD}$  = Power-fail Deselect Voltage):
  - M48Z2M1Y:  $V_{CC} = 4.5$  to  $5.5V$   
 $4.2V \leq V_{PFD} \leq 4.5V$
  - M48Z2M1V:  $V_{CC} = 3.0$  to  $3.6V$   
 $2.8V \leq V_{PFD} \leq 3.0V$
- BATTERIES ARE INTERNALLY ISOLATED UNTIL POWER IS APPLIED
- PIN and FUNCTION COMPATIBLE WITH JEDEC STANDARD 2Mb x 8 SRAMs

Figure 1. 36-pin, DIP Module

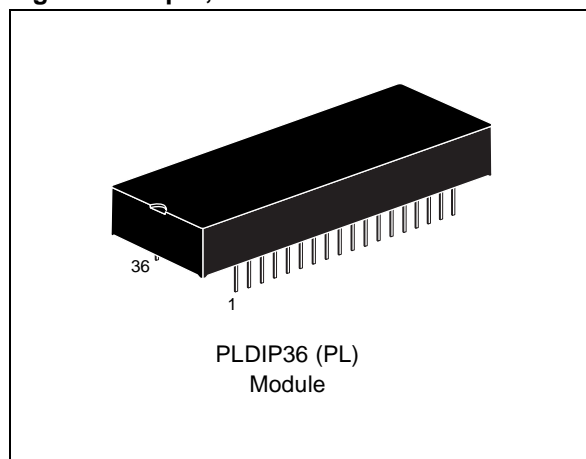

**TABLE OF CONTENTS**

<b>SUMMARY DESCRIPTION</b> .....	<b>3</b>
Figure 2. Logic Diagram .....	3
Table 1. Signal Names .....	3
Figure 3. DIP Connections .....	3
Figure 4. Block Diagram .....	4
<b>MAXIMUM RATING</b> .....	<b>4</b>
Table 2. Absolute Maximum Ratings .....	4
<b>DC AND AC PARAMETERS</b> .....	<b>5</b>
Table 3. Operating and AC Measurement Conditions .....	5
Figure 5. AC Testing Load Circuit .....	5
Table 4. Capacitance .....	5
Table 5. DC Characteristics .....	6
<b>OPERATION MODES</b> .....	<b>6</b>
Table 6. Operating Modes .....	6
<b>READ Mode</b> .....	<b>7</b>
Figure 6. Address Controlled, READ Mode AC Waveforms .....	7
Figure 7. Chip Enable or Output Enable Controlled, READ Mode AC Waveforms .....	7
Table 7. READ Mode AC Characteristics .....	8
<b>WRITE Mode</b> .....	<b>9</b>
Figure 8. WRITE Enable Controlled, WRITE Mode AC Waveforms .....	9
Figure 9. Chip Enable Controlled, WRITE Mode AC Waveforms .....	9
Table 8. WRITE Mode AC Characteristics .....	10
<b>Data Retention Mode</b> .....	<b>11</b>
Figure 10. Power Down/Up Mode AC Waveforms .....	11
Table 9. Power Down/Up AC Characteristics .....	12
Table 10. Power Down/Up Trip Points DC Characteristics .....	12
<b>V<sub>CC</sub> Noise And Negative Going Transients</b> .....	<b>13</b>
Figure 11. Supply Voltage Protection .....	13
<b>PACKAGE MECHANICAL INFORMATION</b> .....	<b>14</b>
<b>PART NUMBERING</b> .....	<b>15</b>
<b>REVISION HISTORY</b> .....	<b>16</b>

**SUMMARY DESCRIPTION**

The M48Z2M1Y/V ZEROPOWER® RAM is a non-volatile 16,777,216-bit, Static RAM organized as 2,097,152 words by 8 bits. The device combines two internal lithium batteries, CMOS SRAMs and a control circuit in a plastic 36-pin DIP, long Module.

The ZEROPOWER RAM replaces industry standard SRAMs. It provides the nonvolatility of PROMs without any requirement for special WRITE timing or limitations on the number of WRITES that can be performed.

**Figure 2. Logic Diagram**

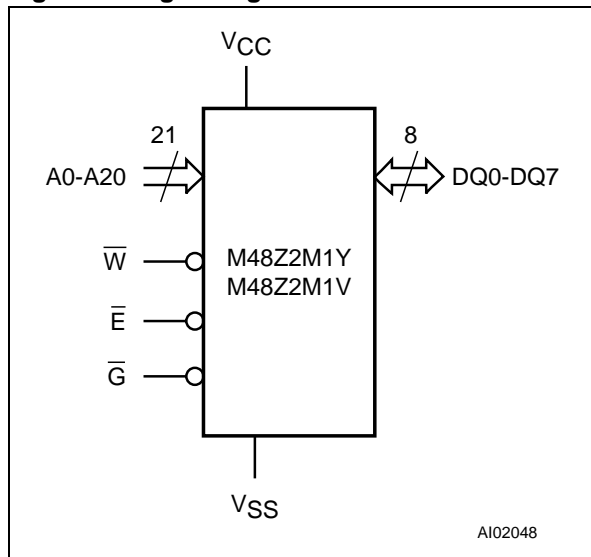

**Table 1. Signal Names**

A0-A20	Address Inputs
DQ0-DQ7	Data Inputs / Outputs
$\bar{E}$	Chip Enable
$\bar{G}$	Output Enable
$\bar{W}$	WRITE Enable
Vcc	Supply Voltage
Vss	Ground
NC	Not Connected Internally

**Figure 3. DIP Connections**

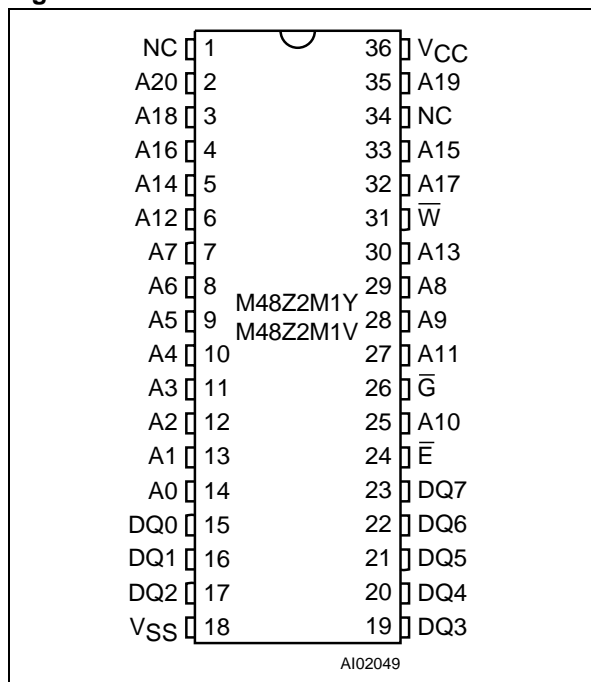
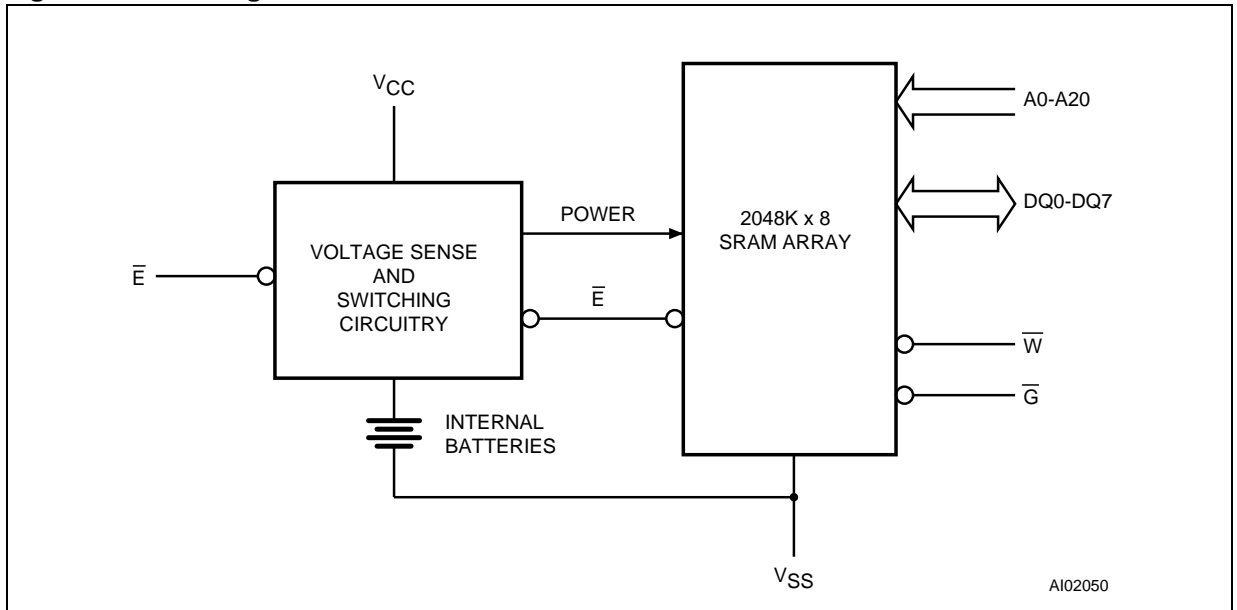

Figure 4. Block Diagram



**MAXIMUM RATING**

Stressing the device above the rating listed in the “Absolute Maximum Ratings” table may cause permanent damage to the device. These are stress ratings only and operation of the device at these or any other conditions above those indicated in the Operating sections of this specification is

not implied. Exposure to Absolute Maximum Rating conditions for extended periods may affect device reliability. Refer also to the STMicroelectronics SURE Program and other relevant quality documents.

Table 2. Absolute Maximum Ratings

Symbol	Parameter	Value	Unit	
T <sub>A</sub>	Ambient Operating Temperature	0 to 70	°C	
T <sub>STG</sub>	Storage Temperature (V <sub>CC</sub> Off)	-40 to 85	°C	
T <sub>BIAS</sub>	Temperature Under Bias	-40 to 85	°C	
T <sub>SLD</sub> <sup>(1)</sup>	Lead Solder Temperature for 10 seconds	260	°C	
V <sub>IO</sub>	Input or Output Voltages	M48Z2M1Y	-0.3 to 7	V
		M48Z2M1V	-0.3 to 4.6	V
V <sub>CC</sub>	Supply Voltage	M48Z2M1Y	-0.3 to 7	V
		M48Z2M1V	-0.3 to 4.6	V
I <sub>O</sub>	Output Current	20	mA	
P <sub>D</sub>	Power Dissipation	1	W	

Note: 1. Soldering temperature not to exceed 260°C for 10 seconds (total thermal budget not to exceed 150°C for longer than 30 seconds).

**CAUTION:** Negative undershoots below -0.3V are not allowed on any pin while in the Battery Back-up mode.

## DC AND AC PARAMETERS

This section summarizes the operating and measurement conditions, as well as the DC and AC characteristics of the device. The parameters in the following DC and AC Characteristic tables are derived from tests performed under the Measure-

ment Conditions listed in the relevant tables. Designers should check that the operating conditions in their projects match the measurement conditions when using the quoted parameters.

**Table 3. Operating and AC Measurement Conditions**

Parameter	M48Z2M1Y	M48Z2M1V	Unit
Supply Voltage ( $V_{CC}$ )	4.5 to 5.5	3.0 to 3.6	V
Ambient Operating Temperature ( $T_A$ )	0 to 70	0 to 70	°C
Load Capacitance ( $C_L$ )	100	50	pF
Input Rise and Fall Times	$\leq 5$	$\leq 5$	ns
Input Pulse Voltages	0 to 3	0 to 3	V
Input and Output Timing Ref. Voltages	1.5	1.5	V

Note: Output Hi-Z is defined as the point where data is no longer driven.

**Figure 5. AC Testing Load Circuit**

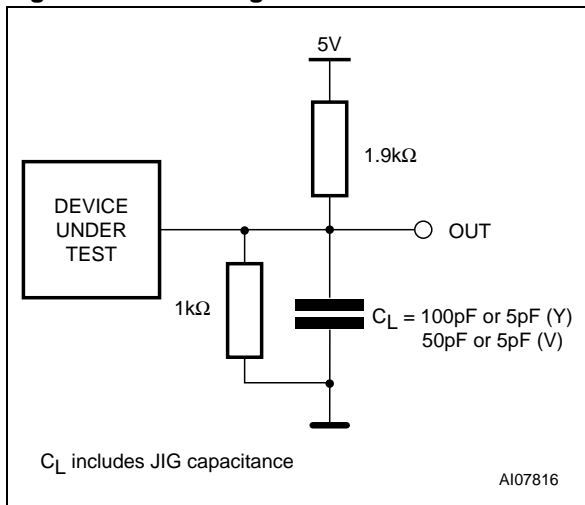

**Table 4. Capacitance**

Symbol	Parameter <sup>(1,2)</sup>	Min	Max	Unit
$C_{IN}$	Input Capacitance		40	pF
$C_{IO}^{(3)}$	Input / Output Capacitance		40	pF

Note: 1. Effective capacitance measured with power supply at 5V; sampled only, not 100% tested.

2. Outputs deselected.

3. At 25°C.

**Table 5. DC Characteristics**

Sym	Parameter	Test Condition <sup>(1)</sup>	M48Z2M1Y		M48Z2M1V		Unit
			Min	Max	Min	Max	
$I_{LI}^{(2)}$	Input Leakage Current	$0V \leq V_{IN} \leq V_{CC}$		±4		±4	µA
$I_{LO}^{(2)}$	Output Leakage Current	$0V \leq V_{OUT} \leq V_{CC}$		±4		±4	µA
$I_{CC}$	Supply Current	$\bar{E} = V_{IL}$ , Outputs open		140		50	mA
$I_{CC1}$	Supply Current (Standby) TTL	$\bar{E} = V_{IH}$		10		2	mA
$I_{CC2}$	Supply Current (Standby) CMOS	$\bar{E} \geq V_{CC} - 0.2V$		8		1	mA
$V_{IL}$	Input Low Voltage		-0.3	0.8	-0.3	0.6	V
$V_{IH}$	Input High Voltage		2.2	$V_{CC} + 0.3$	2.2	$V_{CC} + 0.3$	V
$V_{OL}$	Output Low Voltage	$I_{OL} = 2.1mA$		0.4		0.4	V
$V_{OH}$	Output High Voltage	$I_{OH} = -1mA$	2.4		2.2		V

Note: 1. Valid for Ambient Operating Temperature:  $T_A = 0$  to  $70^\circ C$ ;  $V_{CC} = 4.5$  to  $5.5V$  or  $3.0$  to  $3.6V$  (except where noted).

2. Outputs deselected.

## OPERATION MODES

The M48Z2M1Y/V has its own Power-fail Detect Circuit. The control circuitry constantly monitors the single 5V supply for an out of tolerance condition. When  $V_{CC}$  is out of tolerance, the circuit write protects the SRAM, providing a high degree of

data security in the midst of unpredictable system operations brought on by low  $V_{CC}$ . As  $V_{CC}$  falls below approximately 3V, the control circuitry connects the batteries which sustain data until valid power returns.

**Table 6. Operating Modes**

Mode	$V_{CC}$	$\bar{E}$	$\bar{G}$	$\bar{W}$	DQ0-DQ7	Power
Deselect	3.0 to 3.6V or 4.5 to 5.5V	$V_{IH}$	X	X	High Z	Standby
WRITE		$V_{IL}$	X	$V_{IL}$	$D_{IN}$	Active
READ		$V_{IL}$	$V_{IL}$	$V_{IH}$	$D_{OUT}$	Active
READ		$V_{IL}$	$V_{IH}$	$V_{IH}$	High Z	Active
Deselect	$V_{SO}$ to $V_{PFD}$ (min) <sup>(1)</sup>	X	X	X	High Z	CMOS Standby
Deselect	$\leq V_{SO}$ <sup>(1)</sup>	X	X	X	High Z	Battery Back-up Mode

Note: X =  $V_{IH}$  or  $V_{IL}$ ;  $V_{SO}$  = Battery Back-up Switchover Voltage.

1. See Table 10, page 12 for details.

## READ Mode

The M48Z2M1Y/V is in the READ Mode whenever  $\overline{W}$  (WRITE Enable) is high and  $\overline{E}$  (Chip Enable) is low. The device architecture allows ripple-through access of data from eight of 16,777,216 locations in the static storage array. Thus, the unique address specified by the 21 Address Inputs defines which one of the 2,097,152 bytes of data is to be accessed. Valid data will be available at the Data I/O pins within Address Access time ( $t_{AVQV}$ ) after the last address input signal is stable, providing that the  $\overline{E}$  (Chip Enable) and  $\overline{G}$  (Output Enable) access times are also satisfied. If the  $\overline{E}$  and  $\overline{G}$  ac-

cess times are not met, valid data will be available after the later of Chip Enable Access time ( $t_{ELQV}$ ) or Output Enable Access Time ( $t_{GLQV}$ ). The state of the eight three-state Data I/O signals is controlled by  $\overline{E}$  and  $\overline{G}$ . If the outputs are activated before  $t_{AVQV}$ , the data lines will be driven to an indeterminate state until  $t_{AVQV}$ . If the Address Inputs are changed while  $\overline{E}$  and  $\overline{G}$  remain low, output data will remain valid for Output Data Hold time ( $t_{AXQX}$ ) but will go indeterminate until the next Address Access.

**Figure 6. Address Controlled, READ Mode AC Waveforms**

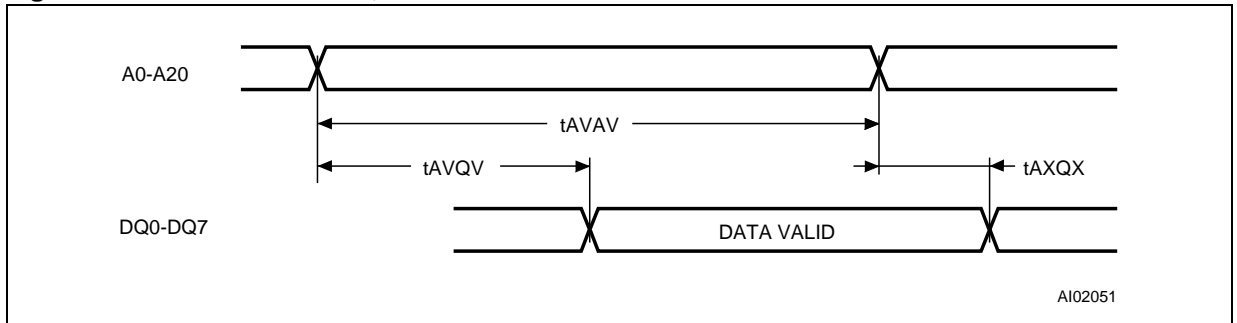

Note: Chip Enable ( $\overline{E}$ ) and Output Enable ( $\overline{G}$ ) = Low, WRITE Enable ( $\overline{W}$ ) = High.

**Figure 7. Chip Enable or Output Enable Controlled, READ Mode AC Waveforms**

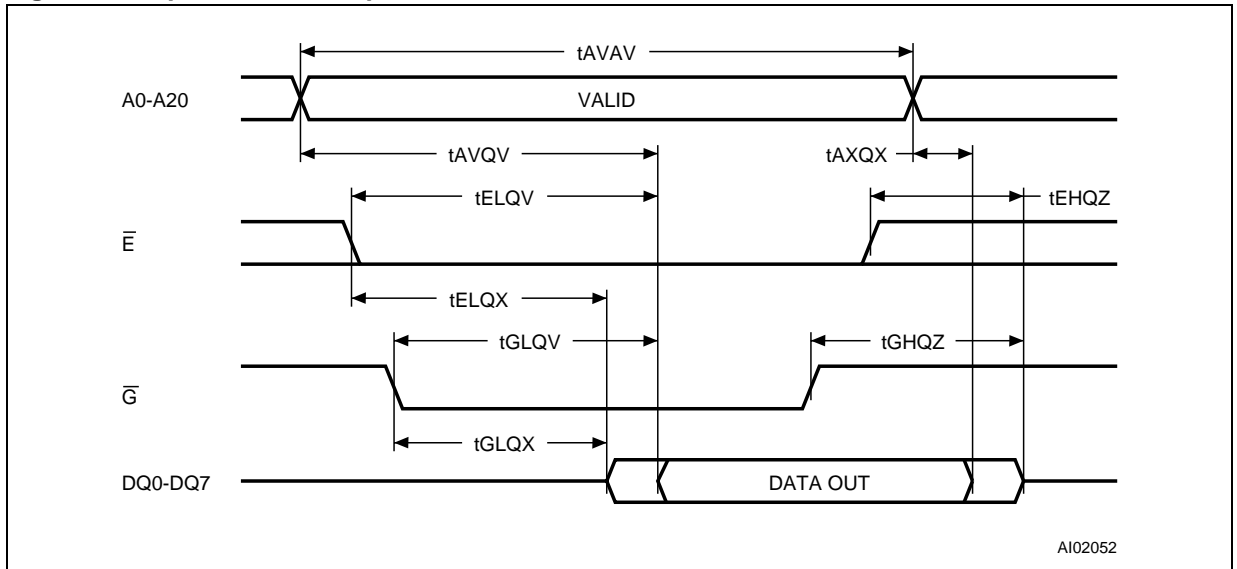

Note: WRITE Enable ( $\overline{W}$ ) = High.

Table 7. READ Mode AC Characteristics

Symbol	Parameter <sup>(1)</sup>	M48Z2M1Y		M48Z2M1V		Unit
		-70		-85		
		Min	Max	Min	Max	
t <sub>AVAV</sub>	READ Cycle Time	70		85		ns
t <sub>AVQV</sub> <sup>(2)</sup>	Address Valid to Output Valid		70		85	ns
t <sub>AXQX</sub> <sup>(2)</sup>	Address Transition to Output Transition	5		5		ns
t <sub>EHQZ</sub> <sup>(3)</sup>	Chip Enable High to Output Hi-Z		30		35	ns
t <sub>ELQV</sub> <sup>(2)</sup>	Chip Enable Low to Output Valid		70		85	ns
t <sub>ELQX</sub> <sup>(3)</sup>	Chip Enable Low to Output Transition	5		5		ns
t <sub>GHQZ</sub> <sup>(3)</sup>	Output Enable High to Output Hi-Z		25		35	ns
t <sub>GLQV</sub> <sup>(2)</sup>	Output Enable Low to Output Valid		35		45	ns
t <sub>GLQX</sub> <sup>(3)</sup>	Output Enable Low to Output Transition	5		5		ns

Note: 1. Valid for Ambient Operating Temperature: T<sub>A</sub> = 0 to 70°C; V<sub>CC</sub> = 4.5 to 5.5V or 3.0 to 3.6V (except where noted).

2. C<sub>L</sub> = 100pF or 50pF (see Figure 5, page 5).

3. C<sub>L</sub> = 5pF (see Figure 5, page 5).

## WRITE Mode

The M48Z2M1Y/V is in the WRITE Mode whenever  $\overline{W}$  and  $\overline{E}$  are active. The start of a WRITE is referenced from the latter occurring falling edge of  $\overline{W}$  or  $\overline{E}$ . A WRITE is terminated by the earlier rising edge of  $\overline{W}$  or  $\overline{E}$ .

The addresses must be held valid throughout the cycle.  $\overline{E}$  or  $\overline{W}$  must return high for minimum of  $t_{E-HAX}$  from  $\overline{E}$  or  $t_{W-HAX}$  from  $\overline{W}$  prior to the initiation

of another READ or WRITE cycle. Data-in must be valid  $t_{DVEH}$  or  $t_{DVWH}$  prior to the end of WRITE and remain valid for  $t_{EHDX}$  or  $t_{WHDX}$  afterward.  $\overline{G}$  should be kept high during WRITE cycles to avoid bus contention; although, if the output bus has been activated by a low on  $\overline{E}$  and  $\overline{G}$ , a low on  $\overline{W}$  will disable the outputs  $t_{WLQZ}$  after  $\overline{W}$  falls.

Figure 8. WRITE Enable Controlled, WRITE Mode AC Waveforms

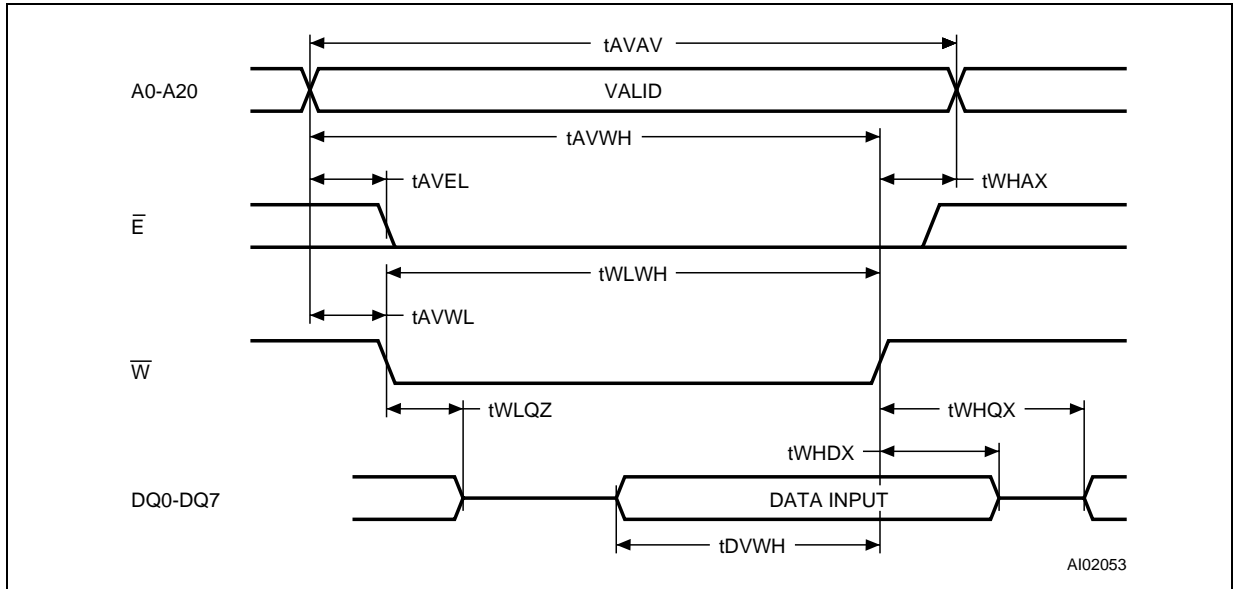

Note: Output Enable ( $\overline{G}$ ) = High.

Figure 9. Chip Enable Controlled, WRITE Mode AC Waveforms

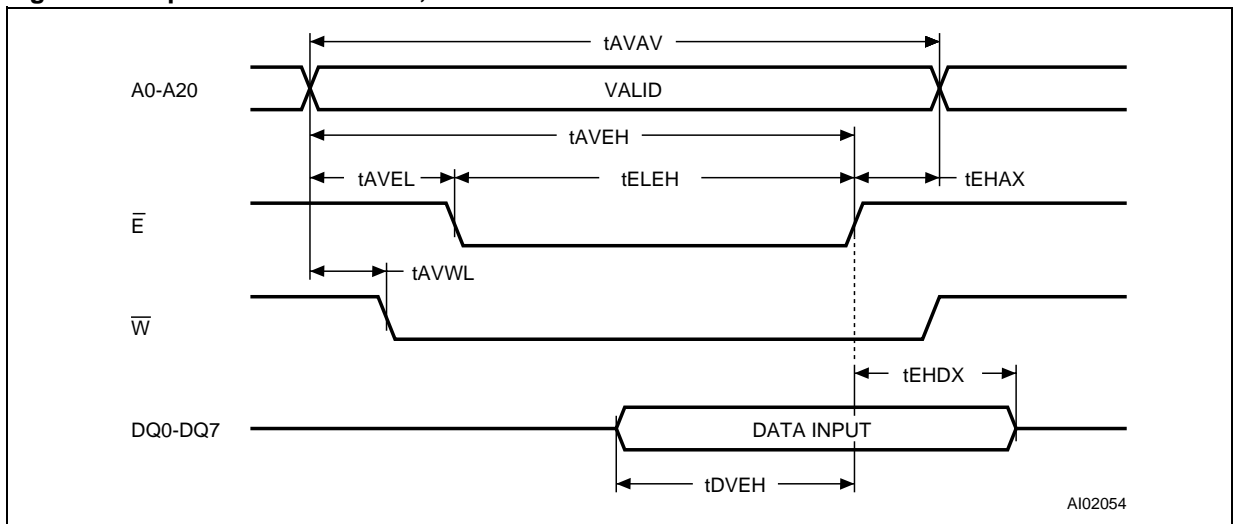

Note: Output Enable ( $\overline{G}$ ) = High.

Table 8. WRITE Mode AC Characteristics

Symbol	Parameter <sup>(1)</sup>	M48Z2M1Y		M48Z2M1V		Unit
		-70		-85		
		Min	Max	Min	Max	
t <sub>AVAV</sub>	WRITE Cycle Time	70		85		ns
t <sub>AVEH</sub>	Address Valid to Chip Enable High	65		75		ns
t <sub>AVEL</sub>	Address Valid to Chip Enable Low	0		0		ns
t <sub>AVWH</sub>	Address Valid to WRITE Enable High	65		75		ns
t <sub>AVWL</sub>	Address Valid to WRITE Enable Low	0		0		ns
t <sub>DVEH</sub>	Input Valid to Chip Enable High	30		35		ns
t <sub>DVWH</sub>	Input Valid to WRITE Enable High	30		35		ns
t <sub>EHAX</sub>	Chip Enable High to Address Transition	15		15		ns
t <sub>EHDX</sub>	Chip Enable High to Input Transition	10		15		ns
t <sub>ELEH</sub>	Chip Enable Low to Chip Enable High	55		75		ns
t <sub>WHAX</sub>	WRITE Enable High to Address Transition	5		5		ns
t <sub>WHDX</sub>	WRITE Enable High to Input Transition	0		0		ns
t <sub>WHQX</sub> <sup>(2,3)</sup>	WRITE Enable High to Output Transition	5		5		ns
t <sub>WLQZ</sub> <sup>(2,3)</sup>	WRITE Enable Low to Output Hi-Z		25		30	ns
t <sub>WLWH</sub>	WRITE Enable Pulse Width	55		65		ns

Note: 1. Valid for Ambient Operating Temperature: T<sub>A</sub> = 0 to 70°C; V<sub>CC</sub> = 4.5 to 5.5V or 3.0 to 3.6V (except where noted).

2. C<sub>L</sub> = 5pF (see Figure 5, page 5).

3. If  $\bar{E}$  goes low simultaneously with  $\bar{W}$  going low, the outputs remain in the high impedance state.

### Data Retention Mode

With valid  $V_{CC}$  applied, the M48Z2M1Y/V operates as a conventional BYTEWIDE™ static RAM. Should the supply voltage decay, the RAM will automatically power-fail deselect, write protecting itself  $t_{WP}$  after  $V_{CC}$  falls below  $V_{PFD}$ . All outputs become high impedance, and all inputs are treated as “Don't care.”

If power fail detection occurs during a valid access, the memory cycle continues to completion. If the memory cycle fails to terminate within the time  $t_{WP}$ , write protection takes place. When  $V_{CC}$  drops below  $V_{SO}$ , the control circuit switches power to the internal energy source which preserves data.

The internal coin cells will maintain data in the M48Z2M1Y/V after the initial application of  $V_{CC}$  for an accumulated period of at least 10 years when  $V_{CC}$  is less than  $V_{SO}$ . As system power returns and  $V_{CC}$  rises above  $V_{SO}$ , the batteries are disconnected, and the power supply is switched to external  $V_{CC}$ . Write protection continues for  $t_{ER}$  after  $V_{CC}$  reaches  $V_{PFD}$  to allow for processor stabilization. After  $t_{ER}$ , normal RAM operation can resume.

For more information on Battery Storage life refer to the Application Note AN1012.

**Figure 10. Power Down/Up Mode AC Waveforms**

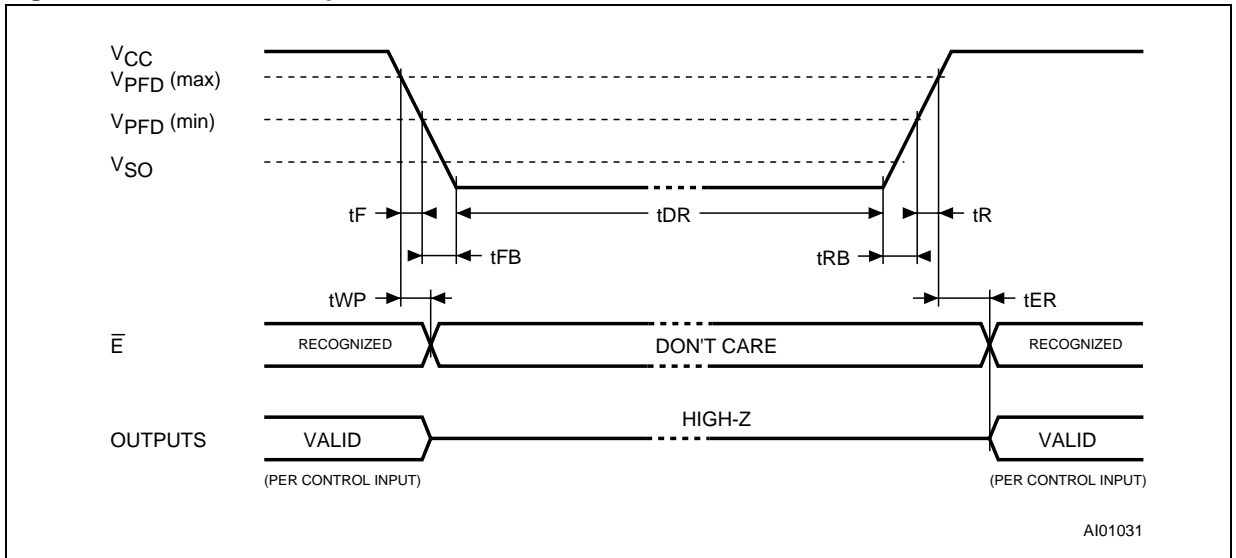

**Table 9. Power Down/Up AC Characteristics**

Symbol	Parameter <sup>(1)</sup>		Min	Max	Unit
$t_{ER}$	$\bar{E}$ Recovery Time		40	120	ms
$t_F^{(2)}$	$V_{PFD}(\max)$ to $V_{PFD}(\min)$ $V_{CC}$ Fall Time		300		$\mu s$
$t_{FB}^{(3)}$	$V_{PFD}(\min)$ to $V_{SO}$ $V_{CC}$ Fall Time	M48Z2M1Y	10		$\mu s$
		M48Z2M1V	150		$\mu s$
$t_R$	$V_{PFD}(\min)$ to $V_{PFD}(\max)$ $V_{CC}$ Rise Time		10		$\mu s$
$t_{WP}$	Write Protect Time from $V_{CC} = V_{PFD}$	M48Z2M1Y	40	150	$\mu s$
		M48Z2M1V	40	250	$\mu s$

Note: 1. Valid for Ambient Operating Temperature:  $T_A = 0$  to  $70^\circ C$ ;  $V_{CC} = 4.5$  to  $5.5V$  or  $3.0$  to  $3.6V$  (except where noted).  
 2.  $V_{PFD}(\max)$  to  $V_{PFD}(\min)$  fall time of less than  $t_F$  may result in deselection/write protection not occurring until  $200\mu s$  after  $V_{CC}$  passes  $V_{PFD}(\min)$ .  
 3.  $V_{PFD}(\min)$  to  $V_{SS}$  fall time of less than  $t_{FB}$  may cause corruption of RAM data.

**Table 10. Power Down/Up Trip Points DC Characteristics**

Symbol	Parameter <sup>(1,2)</sup>		Min	Typ	Max	Unit
$V_{PFD}$	Power-fail Deselect Voltage	M48Z2M1Y	4.2	4.3	4.5	V
		M48Z2M1V	2.8	2.9	3.0	V
$V_{SO}$	Battery Back-up Switchover Voltage	M48Z2M1Y		3.0		V
		M48Z2M1V		2.45		V
$t_{DR}^{(3)}$	Expected Data Retention Time		10			YEARS

Note: 1. All voltages referenced to  $V_{SS}$ .  
 2. Valid for Ambient Operating Temperature:  $T_A = 0$  to  $70^\circ C$ ;  $V_{CC} = 4.5$  to  $5.5V$  or  $3.0$  to  $3.6V$  (except where noted).  
 3. At  $25^\circ C$ ;  $V_{CC} = 0V$ .

### V<sub>CC</sub> Noise And Negative Going Transients

I<sub>CC</sub> transients, including those produced by output switching, can produce voltage fluctuations, resulting in spikes on the V<sub>CC</sub> bus. These transients can be reduced if capacitors are used to store energy which stabilizes the V<sub>CC</sub> bus. The energy stored in the bypass capacitors will be released as low going spikes are generated or energy will be absorbed when overshoots occur. A ceramic bypass capacitor value of 0.1μF (as shown in Figure 11) is recommended in order to provide the needed filtering.

In addition to transients that are caused by normal SRAM operation, power cycling can generate negative voltage spikes on V<sub>CC</sub> that drive it to values below V<sub>SS</sub> by as much as one volt. These negative spikes can cause data corruption in the SRAM while in battery backup mode. To protect from these voltage spikes, it is recommended to connect a schottky diode from V<sub>CC</sub> to V<sub>SS</sub> (cathode connected to V<sub>CC</sub>, anode to V<sub>SS</sub>). Schottky diode 1N5817 is recommended for through hole and MBRS120T3 is recommended for surface mount.

Figure 11. Supply Voltage Protection

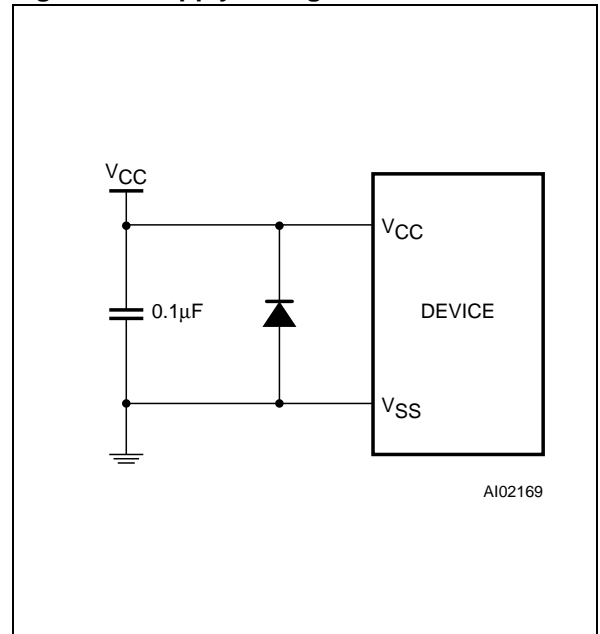

## PACKAGE MECHANICAL INFORMATION

Figure 12. PLDIP36 – 36-pin Plastic DIP Long Module, Package Outline

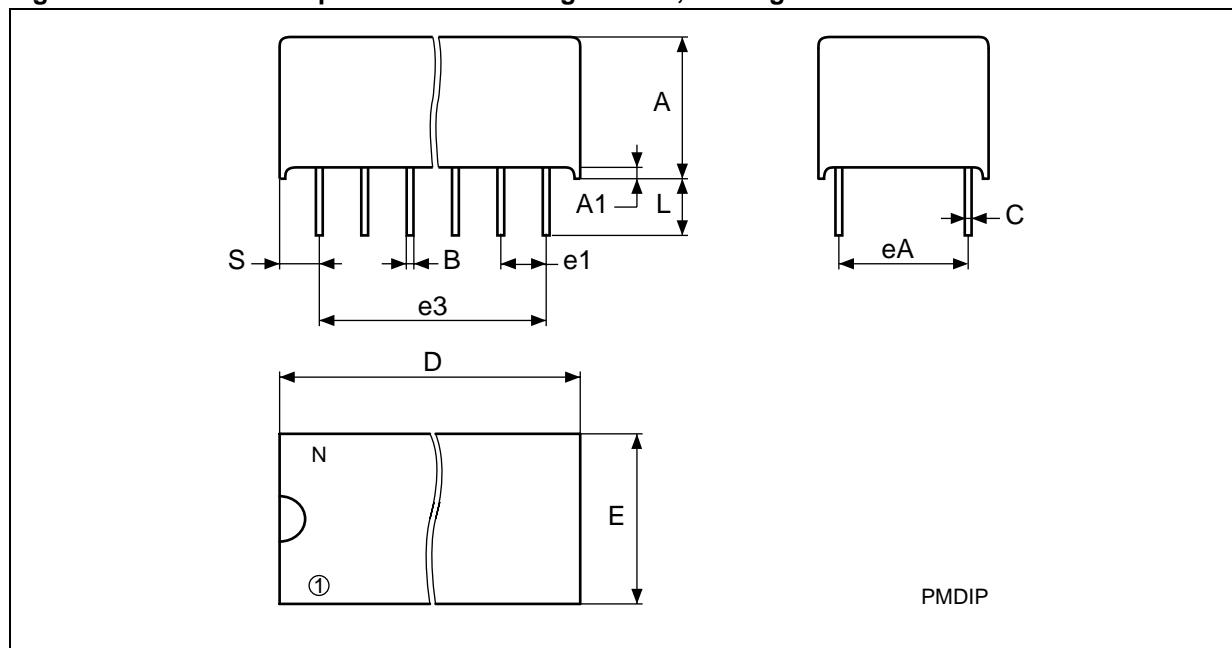

Note: Drawing is not to scale.

Table 11. PLDIP36 – 36-pin Plastic DIP Long Module, Package Mechanical Data

Symb	mm			inches		
	Typ	Min	Max	Typ	Min	Max
A		9.27	9.52		0.3650	0.3748
A1		0.38			0.0150	
B		0.43	0.59		0.0169	0.0232
C		0.20	0.33		0.0079	0.0130
D		52.58	53.34		2.0701	2.1000
E		18.03	18.80		0.7098	0.7402
e1		2.30	2.81		0.0906	0.1106
e3		38.86	47.50		1.5300	1.8701
eA		14.99	16.00		0.5902	0.6299
L		3.05	3.81		0.1201	0.1500
S		4.45	5.33		0.1752	0.2098
N		36			36	

## PART NUMBERING

Table 12. Ordering Information Scheme

Example:	M48Z	2M1Y	-70	PL	1
<b>Device Type</b>					
M48Z					
<b>Supply Voltage and Write Protect Voltage</b>					
2M1Y = $V_{CC} = 4.5$ to $5.5V$ ; $V_{PFD} = 4.2$ to $4.5V$					
2M1V = $V_{CC} = 3.0$ to $3.6V$ ; $V_{PFD} = 2.8$ to $3.0V$					
<b>Speed</b>					
-70 = 70ns (Y)					
-85 = 85ns (V)					
<b>Package</b>					
PL = PLDIP36					
<b>Temperature Range</b>					
1 = 0 to 70°C					
9 <sup>(1)</sup> = Extended Temperature					
<b>Shipping Method</b>					
blank = Tubes					

Note: 1. Contact Sales Offices for availability of Extended Temperature.

For a list of available options (e.g., Speed, Package) or for further information on any aspect of this device, please contact the ST Sales Office nearest you.

**REVISION HISTORY****Table 13. Document Revision History**

<b>Date</b>	<b>Rev. No.</b>	<b>Revision Details</b>
July 1999	1.0	First Issue
31-Aug-00	2.0	From Preliminary Data to Data Sheet
20-Mar-02	3.0	Reformatted; Temperature information added to tables (Table 4, 5, 7, 8, 9, 10)
29-May-02	3.1	Modified "V <sub>CC</sub> Noise and Negative Going Transients" text
28-Mar-03	3.2	Remove 5V/5%, add 3V part (Figure 2, 3, 5; Table 2, 3, 5, 6, 7, 8, 9, 10, 12)

Information furnished is believed to be accurate and reliable. However, STMicroelectronics assumes no responsibility for the consequences of use of such information nor for any infringement of patents or other rights of third parties which may result from its use. No license is granted by implication or otherwise under any patent or patent rights of STMicroelectronics. Specifications mentioned in this publication are subject to change without notice. This publication supersedes and replaces all information previously supplied. STMicroelectronics products are not authorized for use as critical components in life support devices or systems without express written approval of STMicroelectronics.

The ST logo is registered trademark of STMicroelectronics  
All other names are the property of their respective owners.

© 2003 STMicroelectronics - All Rights Reserved

STMicroelectronics GROUP OF COMPANIES

Australia - Brazil - Canada - China - Finland - France - Germany - Hong Kong - India - Israel - Italy - Japan - Malaysia -  
Malta - Morocco - Singapore - Spain - Sweden - Switzerland - United Kingdom - U.S.A.

[www.st.com](http://www.st.com)