



MC1489 MC1489A

QUAD LINE RECEIVERS

- INPUT RESISTANCE $-3k$ to $7k\Omega$
- INPUT SIGNAL RANGE $-\pm 30V$
- INPUT THRESHOLD HYSTERESIS BUILT-IN
- RESPONSE CONTROL :
 - a) LOGIC THRESHOLD SHIFTING
 - b) INPUT NOISE FILTERING

DESCRIPTION

The MC1489 monolithic quad line receivers are designed to interface data terminal equipment with data communications equipment in conformance with the specifications of EIA Standard No. RS-232C.

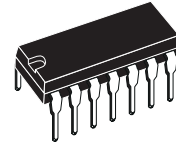

P
DIP14
(Plastic)

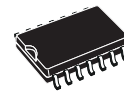

D
SO14
(Plastic Micropackage)

ORDER CODES:

MC1489P, MC1489AP(DIP-14 Plastic)
MC1489D, MC1489AD (SO-14)

PIN CONNECTION (top view)

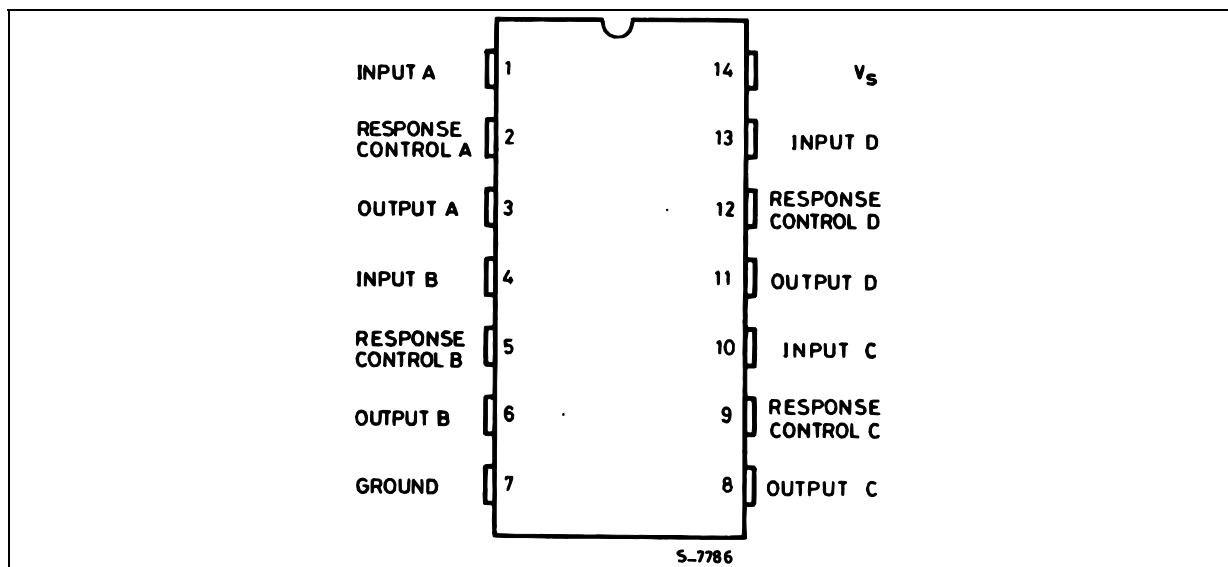

MC1489 / MC1489A

SCHEMATIC DIAGRAM (1/4 of circuit shown)

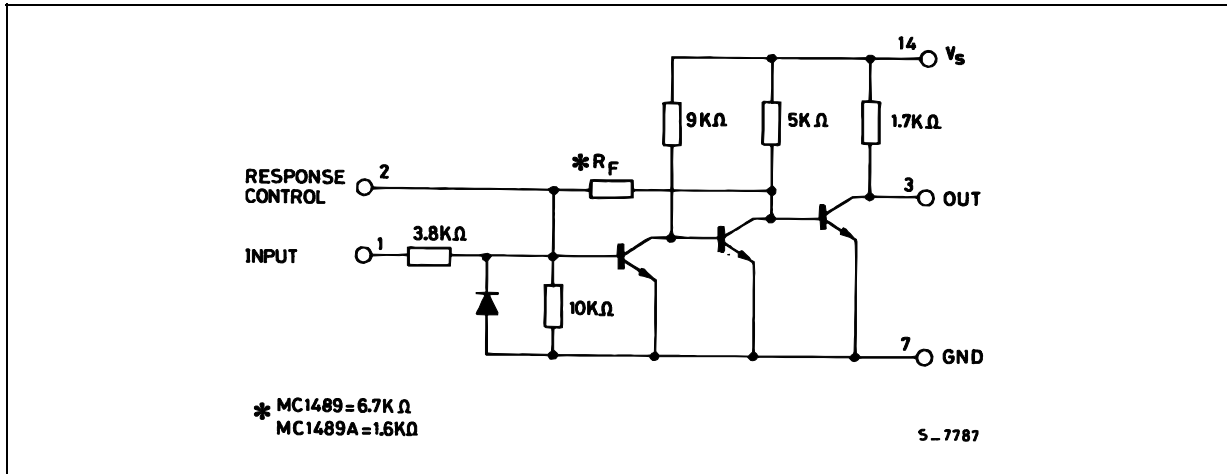

ABSOLUTE MAXIMUM RATINGS

Symbol	Parameter	Value	Unit
V_S	Power Supply Voltage	10	V
V_I	Input Voltage Range	± 30	V
I_{OL}	Output Load Current	20	mA
P_{tot}	Power Dissipation	1	W
T_{amb}	Operating Ambient Temperature	0 to 75	°C
T_{stg}	Storage Temperature Range	-65 to 150	°C

ELECTRICAL CHARACTERISTICS

Response Control Pin is Open ; $V_S = 5V$, $T_{amb} = 0$ to 75°C , unless otherwise specified

Symbol	Parameter	Test Conditions	Min.	Typ.	Max.	Unit
I_{IH}	Positive Input Current	$V_{IH} = 25V$ $V_{IH} = 3V$	3.6 0.43		8.3	mA
I_{IL}	Negative Input Current	$V_{IL} = -25V$ $V_{IL} = -3V$	-3.6 -0.43		-8.3	mA
V_{IH}	Input Turn-on Threshold Voltage	$T_{amb} = 25^\circ\text{C}$, $V_{OL} \leq 0.45$ $I_L = 10\text{mA}$ for MC1489 for MC1489A	1 1.75	1.95	1.5 2.25	V
V_{IL}	Input Turn-off Threshold Voltage	$T_{amb} = 25^\circ\text{C}$, $V_{OL} \geq 2.5V$ $I_L = -0.5\text{mA}$	0.75		1.25	V
V_{OH}	Output Voltage High	$V_{IH} = 0.75V$, $I_L = -0.5\text{mA}$ $I_L = 0.5\text{mA}$ Input Open Circuit	2.5 2.5	4	5 5	V
V_{OL}	Output Voltage Low	$V_{IL} = 3V$, $I_L = 10\text{mA}$		0.2	0.45	V
I_{OS}	Output Short Circuit Current			-3	-4	mA
I_S	Power Supply Current	All gates "on", $I_o = 0\text{mA}$ $V_{IH} = 5V$		16	26	mA
P_C	Power Consumption	$V_{IH} = 5V$		80	130	mW

SWITCHING CHARACTERISTICS

$V_s = 5V$, $T_{amb} = 25^\circ C$, see Figure 1

Symbol	Parameter	Test Conditions	Min.	Typ.	Max.	Unit
t_{PLH}	Propagation delay Time	$R_L = 3.9k\Omega$		25	85	ns
t_{TLH}	Rise Time	$R_L = 3.9k\Omega$		120	175	ns
t_{PHL}	Propagation Delay Time	$R_L = 390\Omega$		25	50	ns
t_{THL}	Fall Time	$R_L = 390\Omega$		10	20	ns

TEST CIRCUITS

Figure 1 :Switching Response

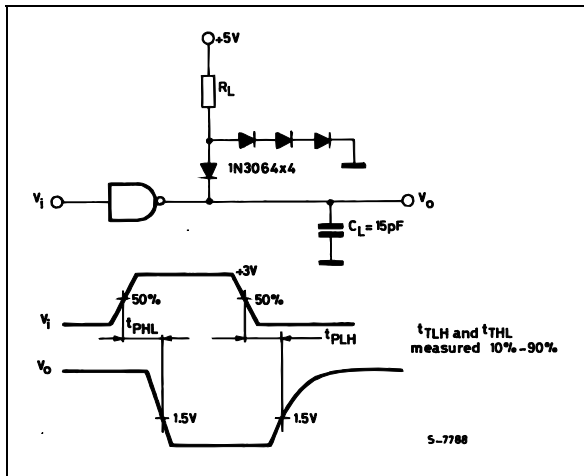

Figure 2 : Response Control Node

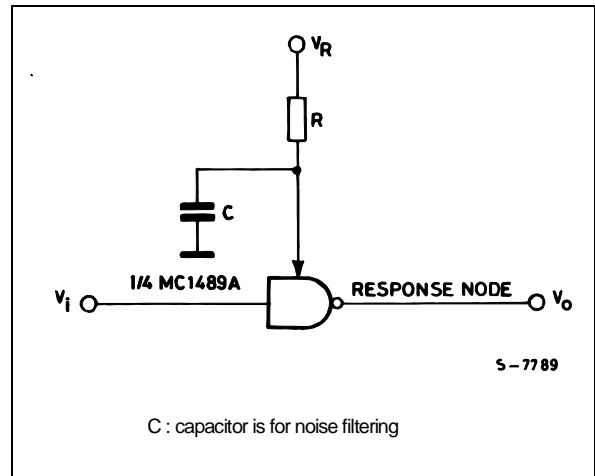

Figure 3 :Input Current

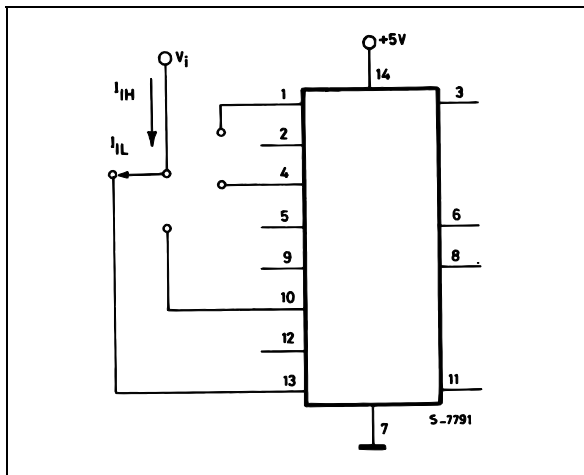

Figure 4 :Output Short-Circuit Current

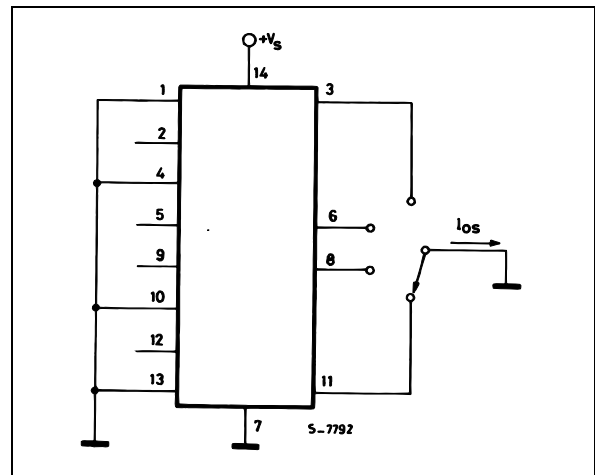

Figure 5 :Output Voltage and Input Threshold Voltage

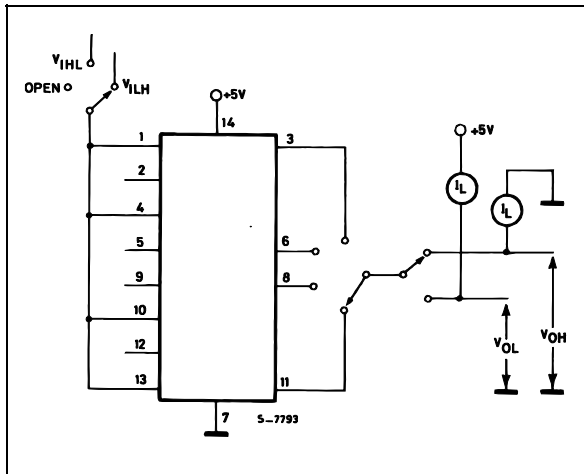
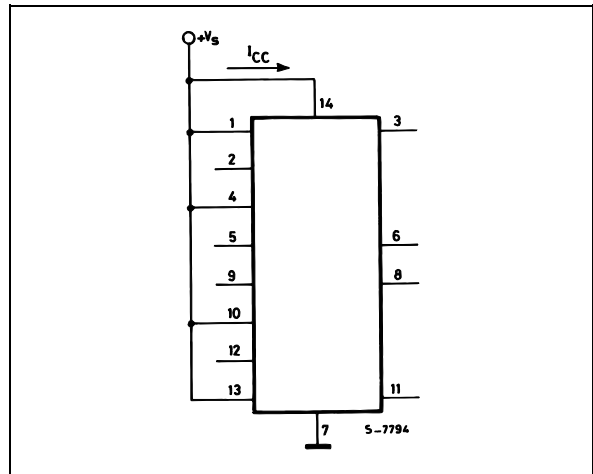
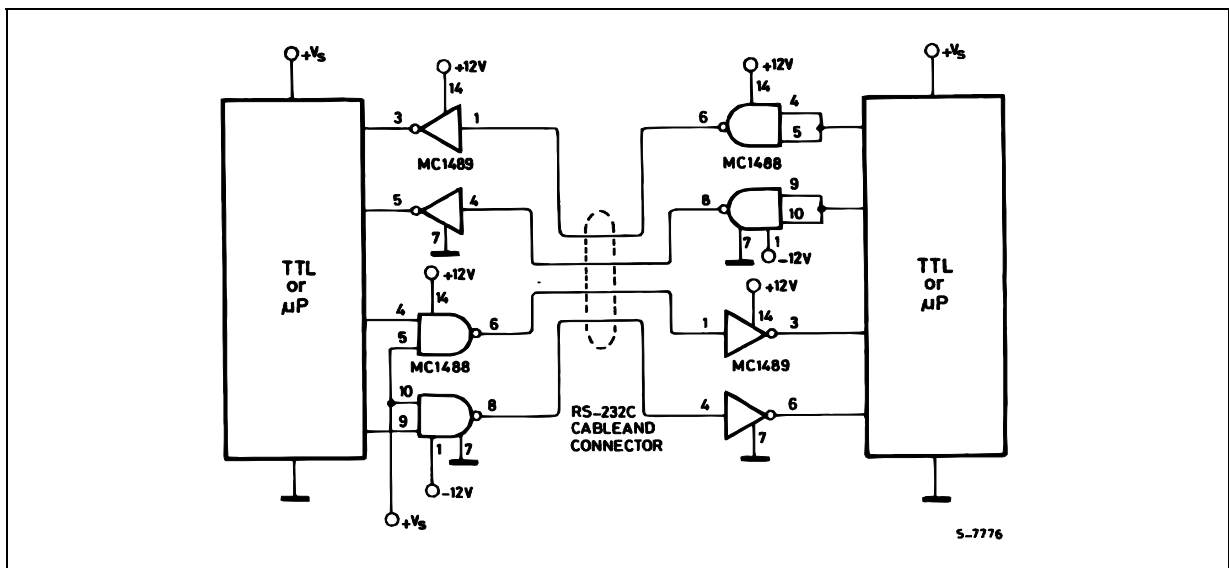

Figure 6 :Power Supply Current



TYPICAL APPLICATION : RS232C Data Transmission



TYPICAL CHARACTERISTICS

$V_S = 5V$, $T_{amb} = 25^\circ C$, unless otherwise specified

Figure 7 : Input Current

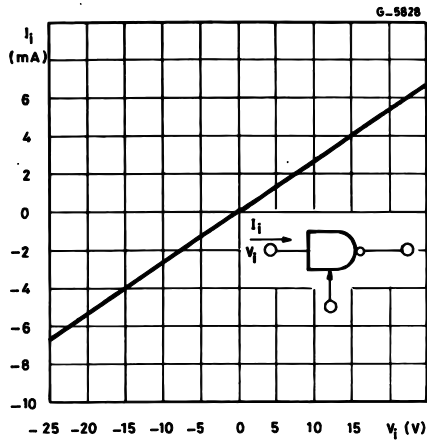

Figure 8 : MC1489 Input Threshold Voltage Adjustment

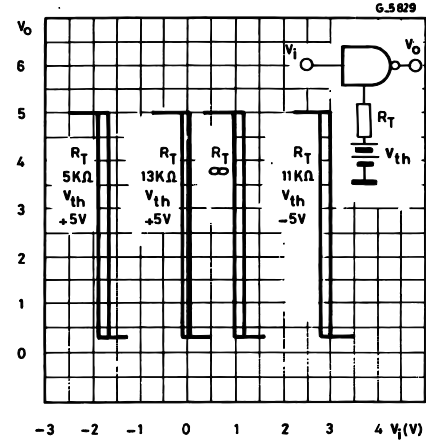

Figure 9 : MC1489A Input Threshold Voltage Adjustment

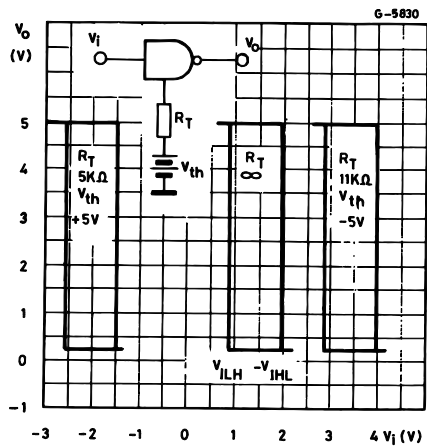

Figure 10 : Input Threshold versus Temperature

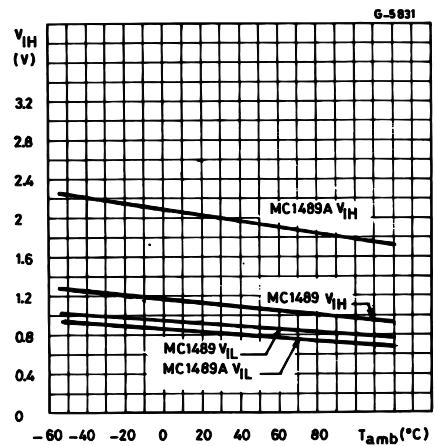
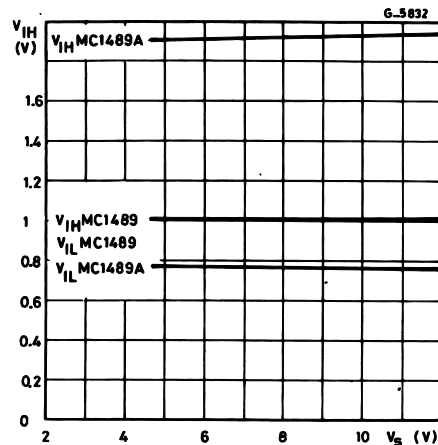

Figure 11 : Input Threshold versus Power Supply Voltag



APPLICATION INFORMATION

GENERAL INFORMATION

The Electronic Industries Association (EIA) has released the RS-232C specification detailing the requirements for the interface between data processing equipment and data communications equipment. This standard specifies not only the number and type of interface leads, but also the voltage levels to be used. The MC1488 quad driver and its companion circuit, the MC1489 quad receiver, provide a complete interface system between DTL or TTL logic levels and the RS-232C defined levels. The RS-232C requirements as applied to receivers are discussed herein.

The required input impedance is defined as between 3000Ω and 7000Ω for input voltages between 3.0 and 25V in magnitude ; and any voltage on the receiver input in an open circuit condition must be less than 2.0V in magnitude. The MC1489 circuits meet these requirements with a maximum open circuit voltage of one V_{BE} .

The receiver shall detect a voltage between - 3.0 and - 25V as a Logic "1" and inputs between + 3.0 and + 2.5V as a Logic "0". On some interchange leads, an open circuit of power "OFF" condition (300Ω or more to ground) shall be decoded as an "OFF" condition or Logic "1". For the reason, the input hysteresis thresholds of the MC1489 circuits are all above ground. Thus an open or grounded input will cause the same output as a negative or Logic "1" input.

DEVICE CHARACTERISTICS

The MC1489 interface receivers have internal feedback from the second stage to the input stage providing input hysteresis for noise

rejection. The MC1489 input has typical turn-on voltage of 1.25V and turn-off of 1.0 V for a typical hysteresis of 250mV. The MC1489A has typical turn-on of 1.95V and turn-off of 0.8V for typically 1.15V of hysteresis.

Each receiver section has an external response control node in addition to the input and output pins, thereby allowing the designer to vary the input threshold voltage levels. A resistor can be connected between this node and an external power supply. Figures 2, 4 and 5 illustrate the input threshold voltage shift possible through this technique.

This response node can also be used for the filtering of the high-frequency, high-energy noise pulses. Figures 8 and 9 show typical noise-pulse rejection for external capacitors of various sizes.

These two operations on the response node can be combined or used individually for many combinations of interfacing applications. The MC1489 circuits are particularly useful for interfacing between MOS circuits and MDTL/MTTL logic systems. In this application, the input threshold voltages are adjusted. (with the appropriate supply and resistor values) to fall in the center of the MOS voltage logic levels (see Figure 10).

The response node may also be used as the receiver input as long as the designer realizes that he may not drive this node with a low impedance source to a voltage greater than one diode above ground or less than one diode below ground. This feature is demonstrated in Figure 11 where two receivers are slaved to the same line that must still meet the RS-232C impedance requirement.

Figure 12 : Typical Turn-on Therhold versus Capacitance from Response Control Pin to GND

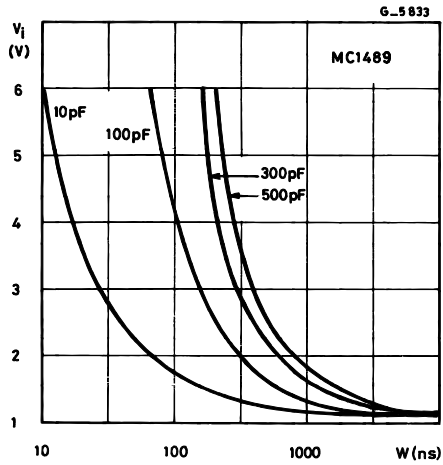

Figure 13 : Typical Turn-on Therhold versus Capacitance from Response Control Pin to GND

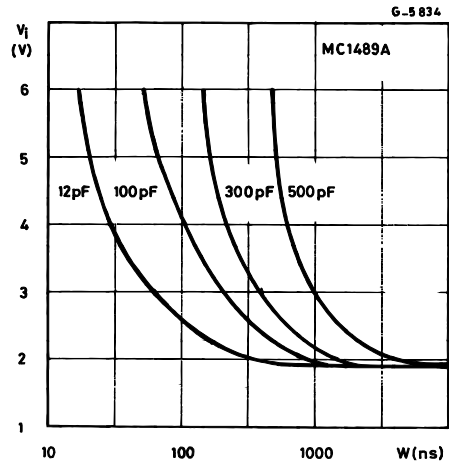
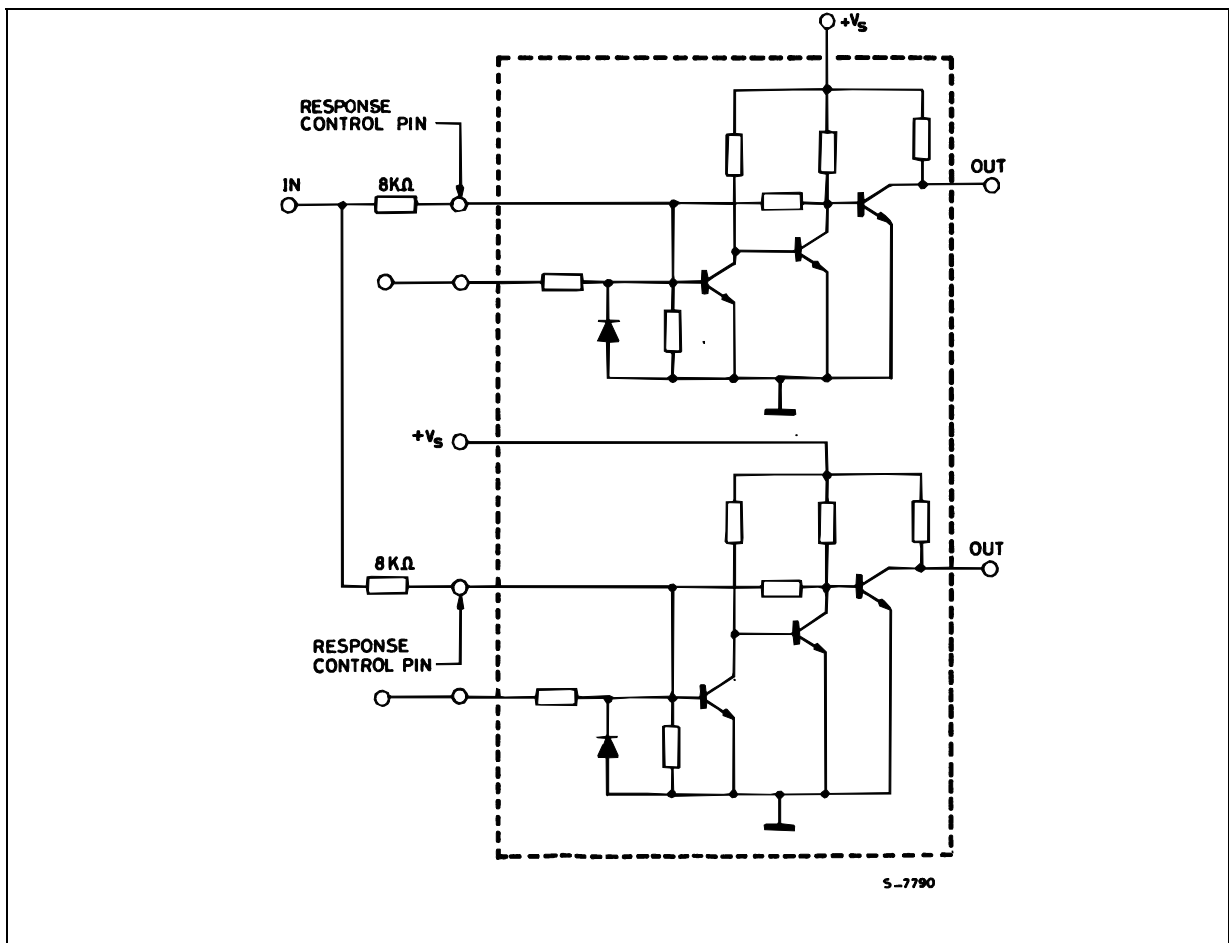
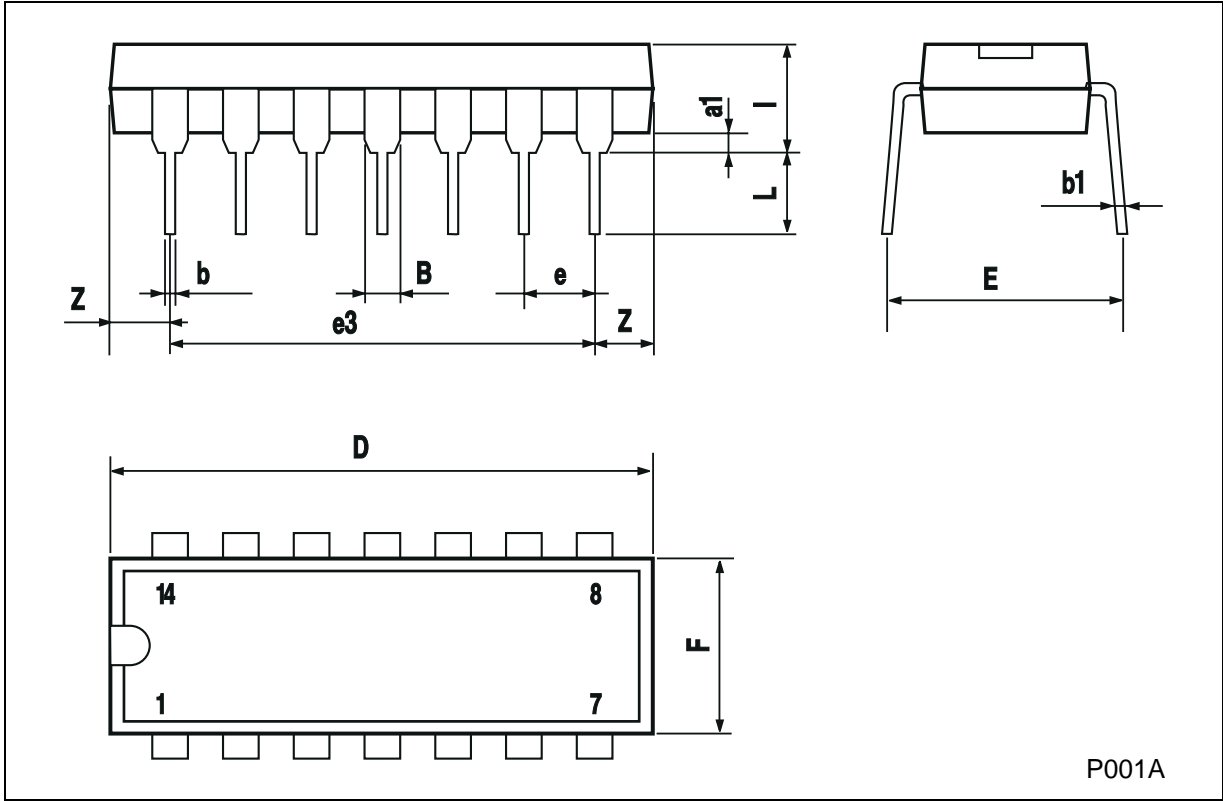

Figure 14 : Typical Paralleling of Two MC1489/A Receivers to Meet RS-232C



Plastic DIP-14 MECHANICAL DATA

DIM.	mm			inch		
	MIN.	TYP.	MAX.	MIN.	TYP.	MAX.
a1	0.51			0.020		
B	1.39		1.65	0.055		0.065
b		0.5			0.020	
b1		0.25			0.010	
D			20			0.787
E		8.5			0.335	
e		2.54			0.100	
e3		15.24			0.600	
F			7.1			0.280
l			5.1			0.201
L		3.3			0.130	
Z	1.27		2.54	0.050		0.100



P001A

SO-14 MECHANICAL DATA

DIM.	mm			inch		
	MIN.	TYP.	MAX.	MIN.	TYP.	MAX.
A			1.75			0.068
a1	0.1		0.2	0.003		0.007
a2			1.65			0.064
b	0.35		0.46	0.013		0.018
b1	0.19		0.25	0.007		0.010
C		0.5			0.019	
c1	45 (typ.)					
D	8.55		8.75	0.336		0.344
E	5.8		6.2	0.228		0.244
e		1.27			0.050	
e3		7.62			0.300	
F	3.8		4.0	0.149		0.157
G	4.6		5.3	0.181		0.208
L	0.5		1.27	0.019		0.050
M			0.68			0.026
S	8 (max.)					

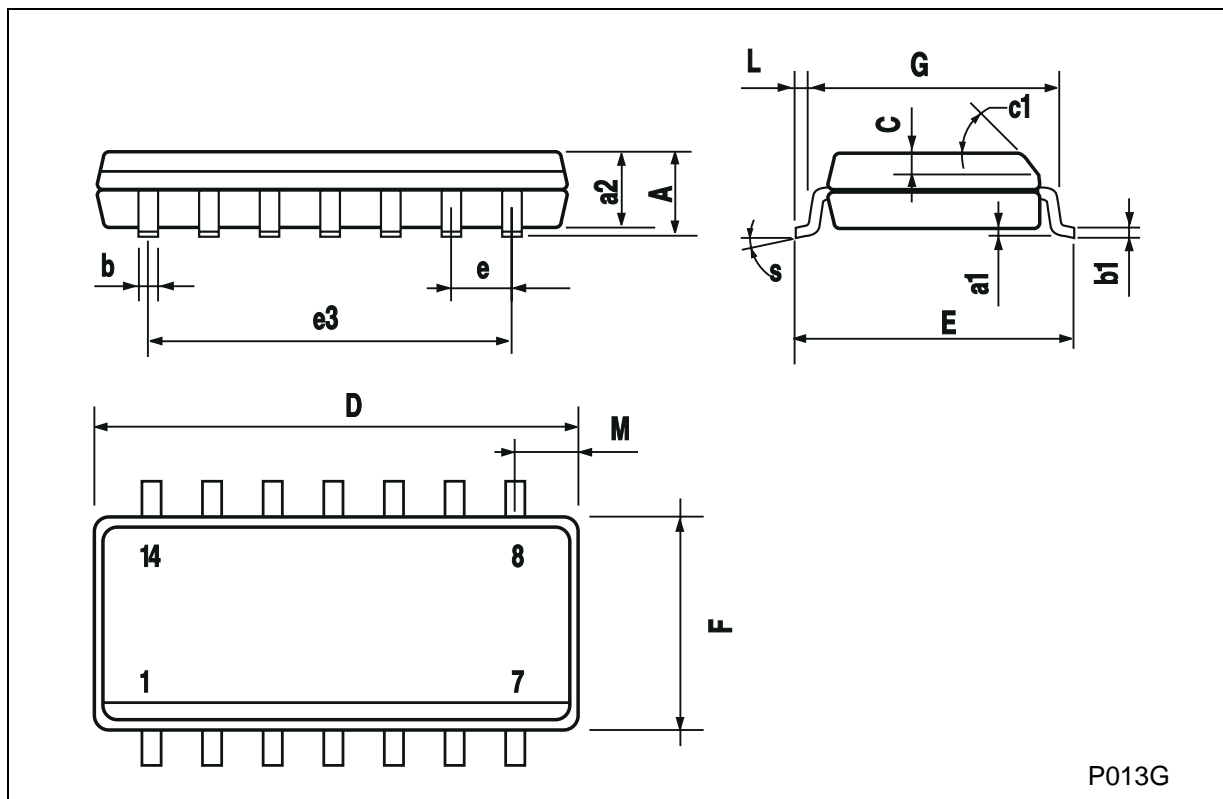

P013G

Information furnished is believed to be accurate and reliable. However, STMicroelectronics assumes no responsibility for the consequences of use of such information nor for any infringement of patents or other rights of third parties which may result from its use. No license is granted by implication or otherwise under any patent or patent rights of STMicroelectronics. Specification mentioned in this publication are subject to change without notice. This publication supersedes and replaces all information previously supplied. STMicroelectronics products are not authorized for use as critical components in life support devices or systems without express written approval of STMicroelectronics.

The ST logo is a registered trademark of STMicroelectronics

© 2000 STMicroelectronics – Printed in Italy – All Rights Reserved

STMicroelectronics GROUP OF COMPANIES

Australia - Brazil - China - Finland - France - Germany - Hong Kong - India - Italy - Japan - Malaysia - Malta - Morocco
Singapore - Spain - Sweden - Switzerland - United Kingdom - U.S.A.

<http://www.st.com>