



MJE13009

HIGH VOLTAGE FAST-SWITCHING NPN POWER TRANSISTOR

- STMicroelectronics PREFERRED SALESTYPE
- HIGH VOLTAGE CAPABILITY
- MINIMUM LOT-TO-LOT SPREAD FOR RELIABLE OPERATION
- LOW BASE-DRIVE REQUIREMENTS
- VERY HIGH SWITCHING SPEED
- FULLY CHARACTERIZED AT 125°C

APPLICATIONS

- ELECTRONIC TRANSFORMER FOR HALOGEN LAMPS
- SWITCH MODE POWER SUPPLIES

DESCRIPTION

The MJE13009 is a high voltage Multi-epitaxial Mesa NPN transistor mounted in Jedec TO-220 plastic package. It uses a Hollow Emitter structure to enhance switching speeds.

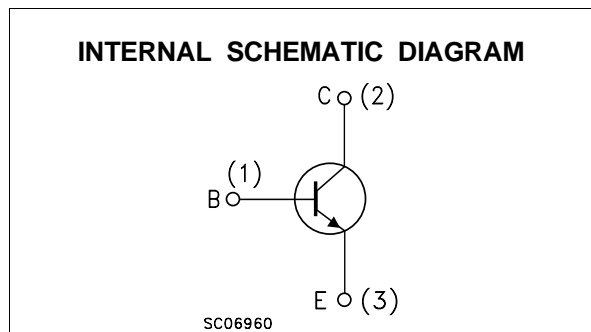
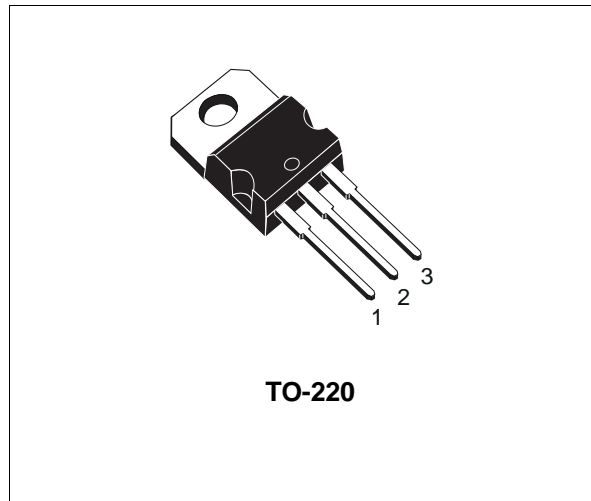

ABSOLUTE MAXIMUM RATINGS

Symbol	Parameter	Value	Unit
V_{CEO}	Collector-Emitter Voltage ($I_B = 0$)	400	V
V_{CEV}	Collector-Emitter Voltage ($V_{BE} = -1.5$ V)	700	V
V_{EBO}	Emitter-Base Voltage ($I_C = 0$)	9	V
I_C	Collector Current	12	A
I_{CM}	Collector Peak Current ($t_p \leq 10$ ms)	25	A
I_B	Base Current	6	A
I_{BM}	Base Peak Current ($t_p \leq 10$ ms)	12	A
I_E	Emitter Current	18	A
I_{EM}	Emitter Peak Current	36	A
P_{tot}	Total Power Dissipation at $T_c \leq 25$ °C	110	W
T_{stg}	Storage Temperature	-65 to 150	°C
T_j	Max. Operating Junction Temperature	150	°C

MJE13009

THERMAL DATA

R _{thj-case}	Thermal Resistance Junction-case	Max	1.14	°C/W
-----------------------	----------------------------------	-----	------	------

ELECTRICAL CHARACTERISTICS (T_{case} = 25 °C unless otherwise specified)

Symbol	Parameter	Test Conditions	Min.	Typ.	Max.	Unit
I _{CEV}	Collector Cut-off Current (V _{EB} = -1.5 V)	V _{CE} = 700 V			1	mA
		V _{CE} = 700 V T _{case} = 100°C			5	mA
I _{EBO}	Emitter Cut-off Current (I _C = 0)	V _{EB} = 9 V			1	mA
V _{CEO(sus)*}	Collector-Emitter Sustaining Voltage (I _B = 0)	I _C = 10 mA	400			V
V _{CE(sat)*}	Collector-Emitter Saturation Voltage	I _C = 5 A I _B = 1 A			1	V
		I _C = 8 A I _B = 1.6 A			1.5	V
		I _C = 12 A I _B = 3 A			3	V
		I _C = 8 A I _B = 1.6 A T _{case} = 100°C			2	V
V _{BE(sat)*}	Base-Emitter Saturation Voltage	I _C = 5 A I _B = 1 A			1.2	V
		I _C = 8 A I _B = 1.6 A			1.6	V
		I _C = 8 A I _B = 1.6 A			1.5	V
		T _{case} = 100°C				
h _{FE} *	DC Current Gain	I _C = 5 A V _{CE} = 5 V	8		40	
		I _C = 8 A V _{CE} = 5 V	6		30	
f _T	Transition Frequency	I _C = 500 mA V _{CE} = 10 V	4			MHz
C _{OB}	Output Capacitance (I _E = 0)	V _{CB} = 10 V f = 0.1 MHz		180		pF
t _{on} t _s t _f	RESISTIVE LOAD Turn-on Time Storage Time Fall Time	V _{CC} = 125 V I _C = 8 A			1.1	μs
		I _{B1} = -I _{B2} = 1.6 A t _p = 25 μs			3	μs
		Duty Cycle ≤ 1 (see figure 2)			0.7	μs

* Pulsed: Pulse duration = 300μs, duty cycle ≤ 2 %

Safe Operating Areas

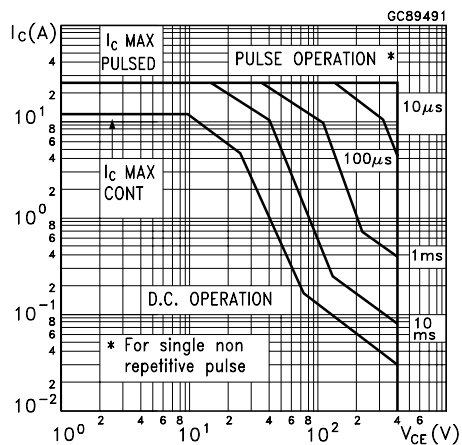

Derating Curve

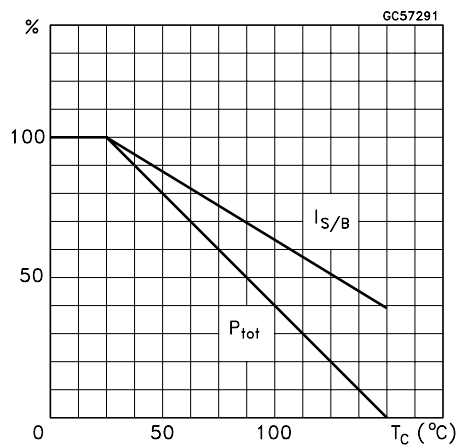

DC Current Gain

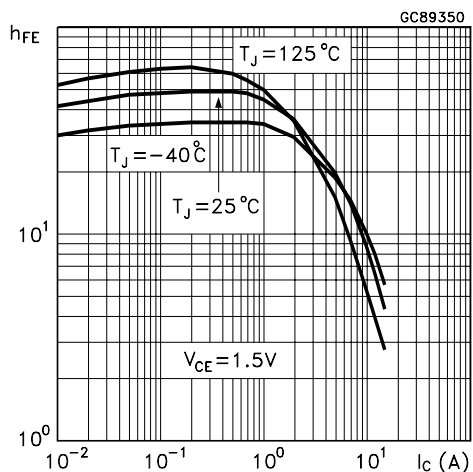

DC Current Gain

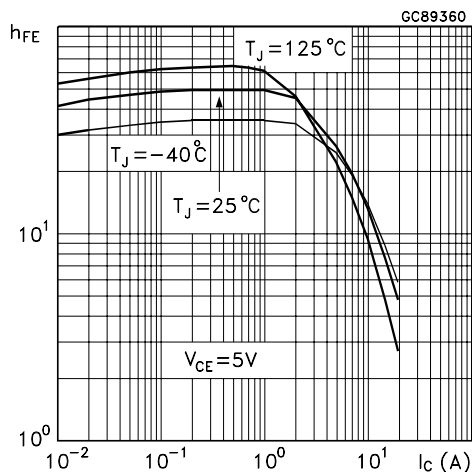

Collector Emitter Saturation Voltage

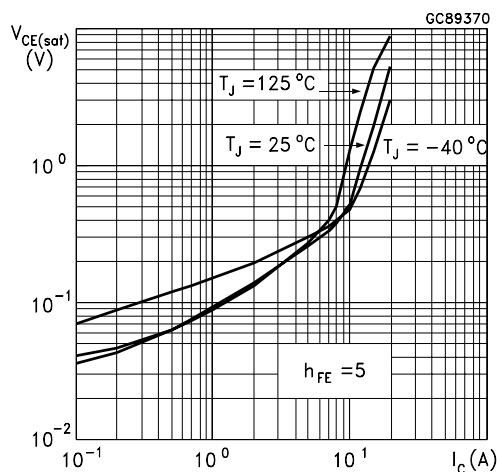

Base Emitter Saturation Voltage

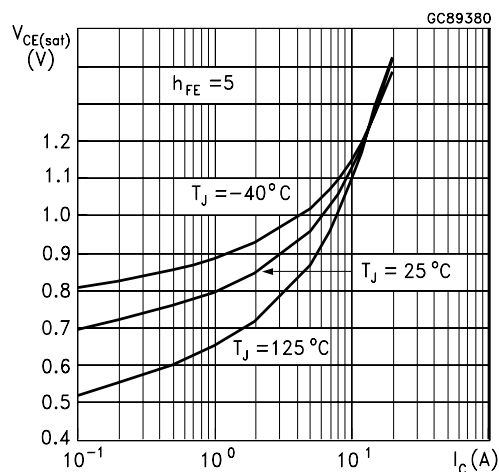

Inductive Load Fall Time

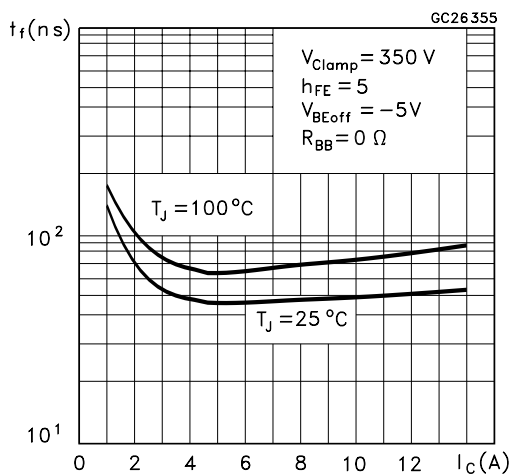

Inductive Load Storage Time

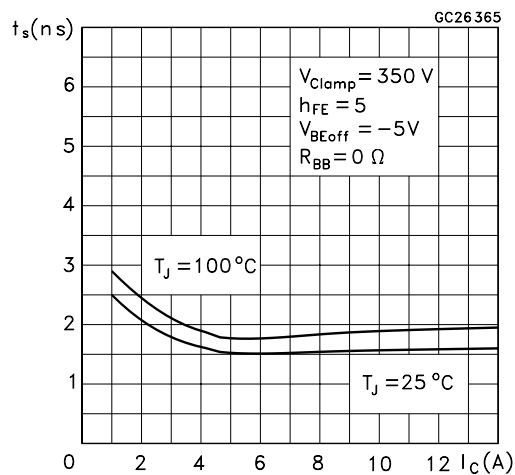

Reverse Biased SOA

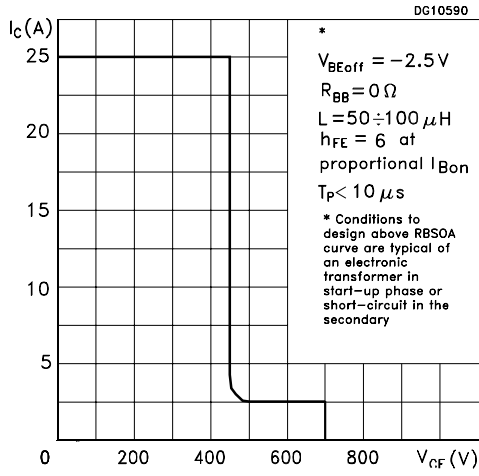

Figure 1: Inductive Load Switching Test Circuit

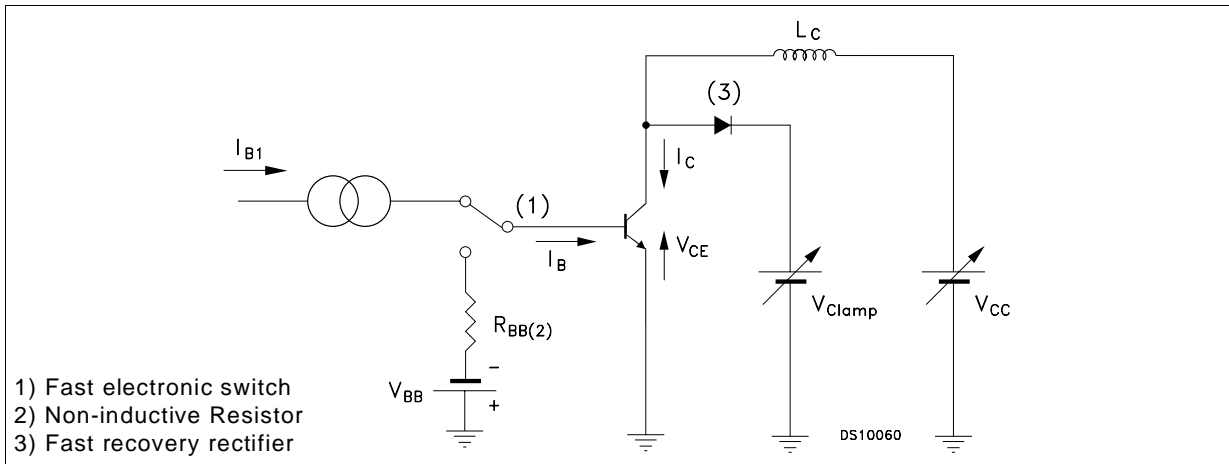
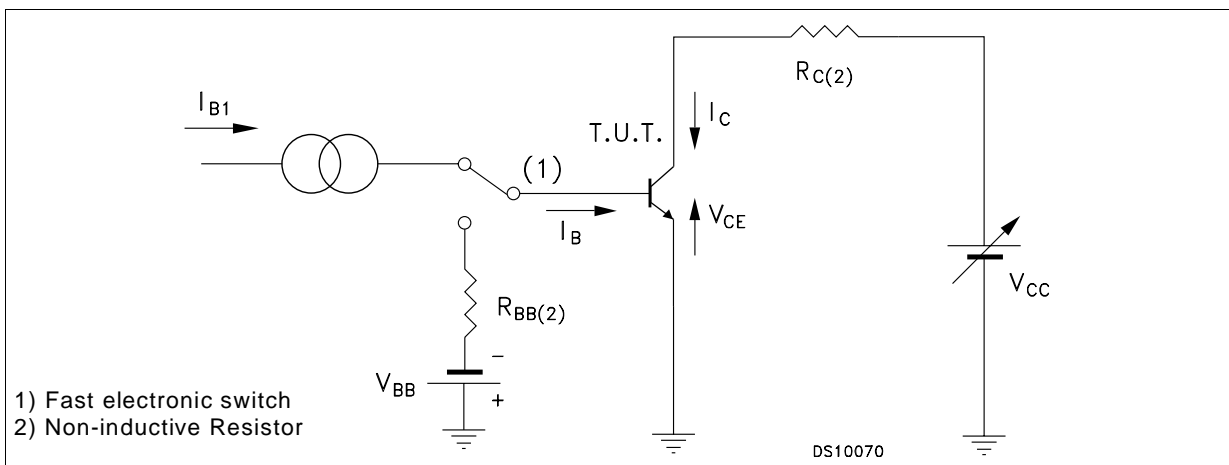
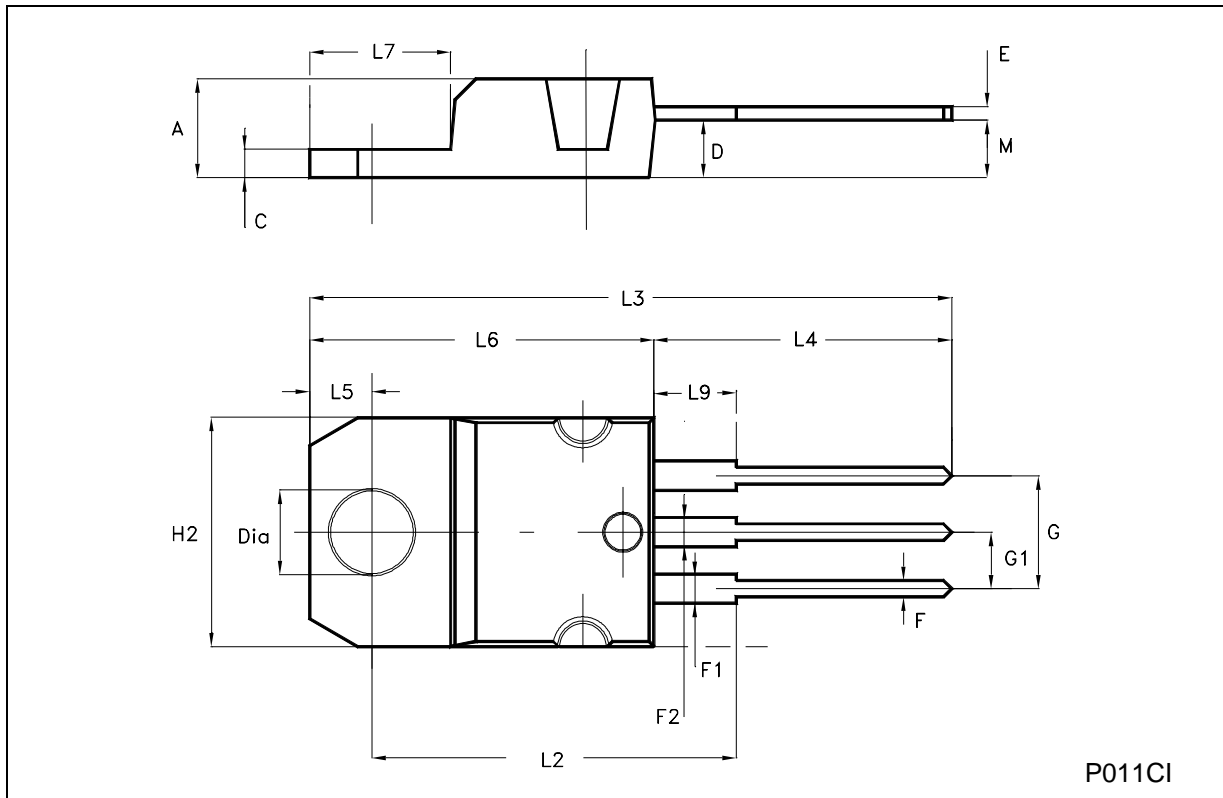

Figure 2: Resistive Load Switching Test Ciurcuit



TO-220 MECHANICAL DATA

DIM.	mm			inch		
	MIN.	TYP.	MAX.	MIN.	TYP.	MAX.
A	4.40		4.60	0.173		0.181
C	1.23		1.32	0.048		0.052
D	2.40		2.72	0.094		0.107
E	0.49		0.70	0.019		0.027
F	0.61		0.88	0.024		0.034
F1	1.14		1.70	0.044		0.067
F2	1.14		1.70	0.044		0.067
G	4.95		5.15	0.194		0.202
G1	2.40		2.70	0.094		0.106
H2	10.00		10.40	0.394		0.409
L2		16.40			0.645	
L4	13.00		14.00	0.511		0.551
L5	2.65		2.95	0.104		0.116
L6	15.25		15.75	0.600		0.620
L7	6.20		6.60	0.244		0.260
L9	3.50		3.93	0.137		0.154
M		2.60			0.102	
DIA.	3.75		3.85	0.147		0.151



Information furnished is believed to be accurate and reliable. However, STMicroelectronics assumes no responsibility for the consequences of use of such information nor for any infringement of patents or other rights of third parties which may result from its use. No license is granted by implication or otherwise under any patent or patent rights of STMicroelectronics. Specification mentioned in this publication are subject to change without notice. This publication supersedes and replaces all information previously supplied. STMicroelectronics products are not authorized for use as critical components in life support devices or systems without express written approval of STMicroelectronics.

The ST logo is a trademark of STMicroelectronics

© 2002 STMicroelectronics – Printed in Italy – All Rights Reserved

STMicroelectronics GROUP OF COMPANIES

Australia - Brazil - Canada - China - Finland - France - Germany - Hong Kong - India - Israel - Italy - Japan - Malaysia - Malta - Morocco - Singapore - Spain - Sweden - Switzerland - United Kingdom - United States.

<http://www.st.com>