

## RF & MICROWAVE TRANSISTORS GENERAL PURPOSE AMPLIFIER APPLICATIONS

- REFRACTORY/GOLD METALLIZATION
- EMITTER SITE BALLASTED
- VSWR CAPABILITY  $\infty:1$  @ RATED CONDITIONS
- HERMETIC STRIPAC<sup>®</sup> PACKAGE
- $P_{OUT} = 1.0$  W MIN. WITH 7.0 dB GAIN @ 3.0 GHz

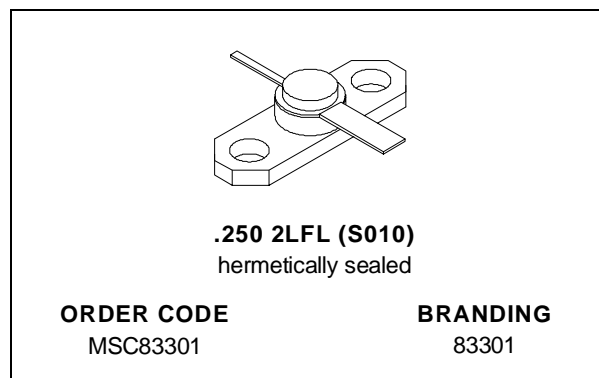

### DESCRIPTION

The MSC83301 is a common base hermetically sealed silicon NPN microwave power transistor utilizing an overlay, emitter site ballasted geometry with a refractory gold metallization system. This device is capable of withstanding an infinite load VSWR at any phase angle under rated conditions. The MSC83301 is designed for Class C amplifier/oscillator applications in the 1.0 - 3.0 GHz frequency range.

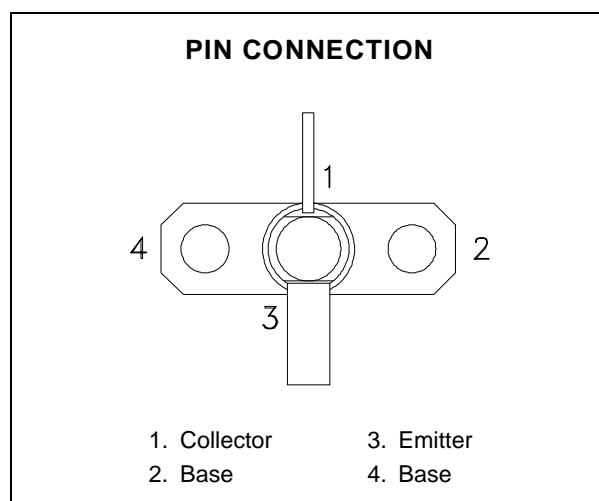

### ABSOLUTE MAXIMUM RATINGS ( $T_{case} = 25^{\circ}C$ )

Symbol	Parameter	Value	Unit
$P_{DISS}$	Power Dissipation* ( $T_C \leq 50^{\circ}C$ )	6.0	W
$I_C$	Device Current*	200	mA
$V_{CC}$	Collector-Supply Voltage*	30	V
$T_J$	Junction Temperature	200	$^{\circ}C$
$T_{STG}$	Storage Temperature	- 65 to +200	$^{\circ}C$

### THERMAL DATA

$R_{TH(j-c)}$	Junction-Case Thermal Resistance*	25	$^{\circ}C/W$
---------------	-----------------------------------	----	---------------

\*Applies only to rated RF amplifier operation

# MSC83301

## ELECTRICAL SPECIFICATIONS (T<sub>case</sub> = 25°C)

### STATIC

Symbol	Test Conditions		Value			Unit
			Min.	Typ.	Max.	
BV <sub>CBO</sub>	I <sub>C</sub> = 1 mA	I <sub>E</sub> = 0 mA	45	—	—	V
BV <sub>EBO</sub>	I <sub>E</sub> = 1 mA	I <sub>C</sub> = 0 mA	3.5	—	—	V
BV <sub>CER</sub>	I <sub>C</sub> = 5 mA	R <sub>BE</sub> = 10 Ω	45	—	—	V
I <sub>CBO</sub>	V <sub>CB</sub> = 28V		—	—	0.5	mA
h <sub>FE</sub>	V <sub>CE</sub> = 5 V	I <sub>C</sub> = 100 mA	30	—	300	—

### DYNAMIC

Symbol	Test Conditions			Value			Unit
				Min.	Typ.	Max.	
P <sub>OUT</sub>	f = 3.0 GHz	P <sub>IN</sub> = 0.20 W	V <sub>CC</sub> = 28 V	1.0	1.3	—	W
η <sub>C</sub>	f = 3.0 GHz	P <sub>IN</sub> = 0.20 W	V <sub>CC</sub> = 28 V	33	36	—	%
P <sub>G</sub>	f = 3.0 GHz	P <sub>IN</sub> = 0.20 W	V <sub>CC</sub> = 28 V	7.0	8.1	—	dB
C <sub>OB</sub>	f = 1 MHz	V <sub>CB</sub> = 28 V		—	—	3.5	pF

### TYPICAL PERFORMANCE

TYPICAL POWER OUTPUT vs FREQUENCY

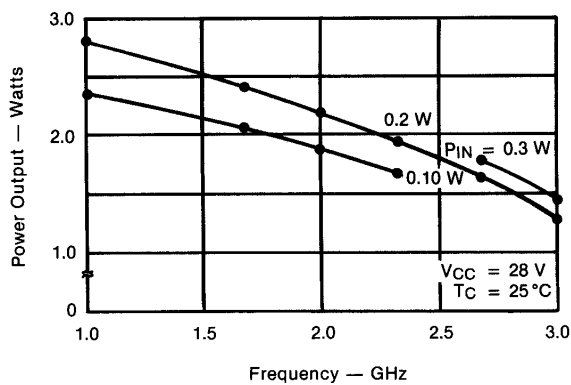

TYPICAL COLLECTOR EFFICIENCY vs FREQUENCY

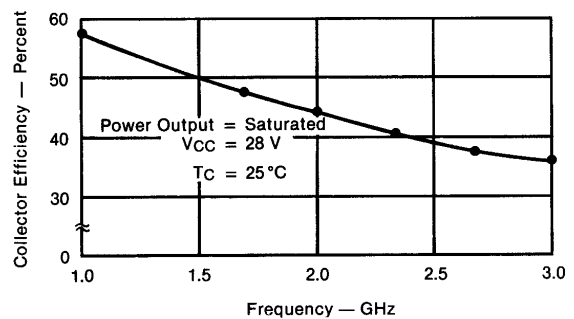

PERCENT POWER OUTPUT & COLLECTOR EFFICIENCY vs COLLECTOR VOLTAGE

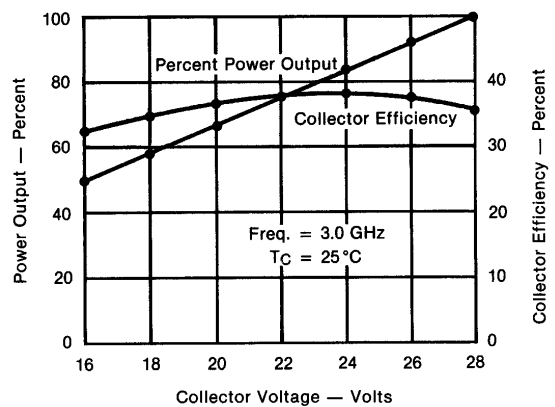

IMPEDANCE DATA

TYPICAL INPUT IMPEDANCE

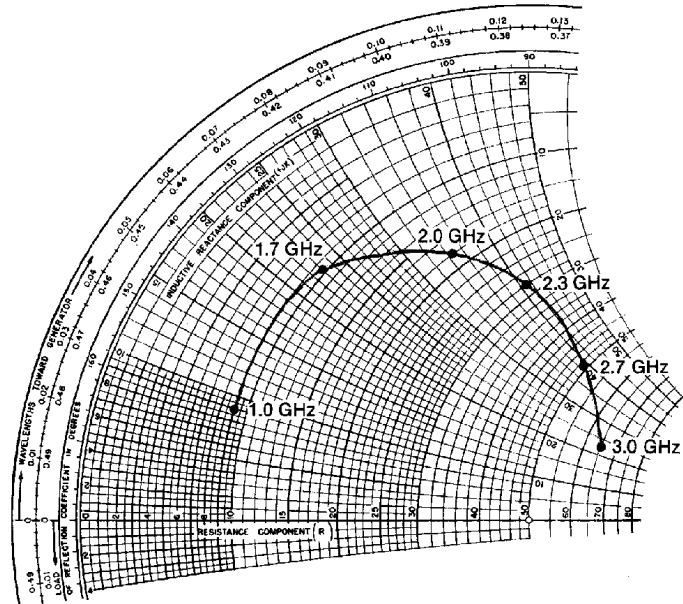
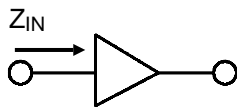

FREQ.	Z <sub>IN</sub> (Ω)	Z <sub>CL</sub> (Ω)
1.0 GHz	9.0 + j 9.0	21.0 + j 48.0
1.7 GHz	9.5 + j 23.0	12.0 + j 32.0
2.0 GHz	18.0 + j 34.5	7.5 + j 22.0
2.3 GHz	28.0 + j 41.0	5.0 + j 13.0
2.7 GHz	49.0 + j 39.0	4.0 + j 7.0
3.0 GHz	65.0 + j 22.0	3.8 + j 3.0

P<sub>OUT</sub> = Saturated  
 V<sub>CC</sub> = 28 V  
 Normalized to 50 ohms

TYPICAL COLLECTOR LOAD IMPEDANCE

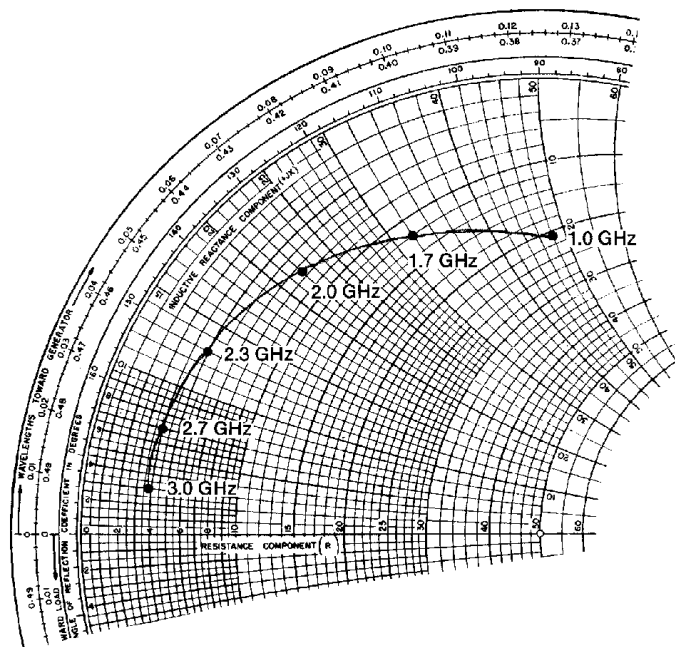
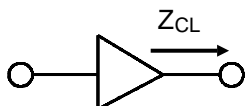

TEST CIRCUIT

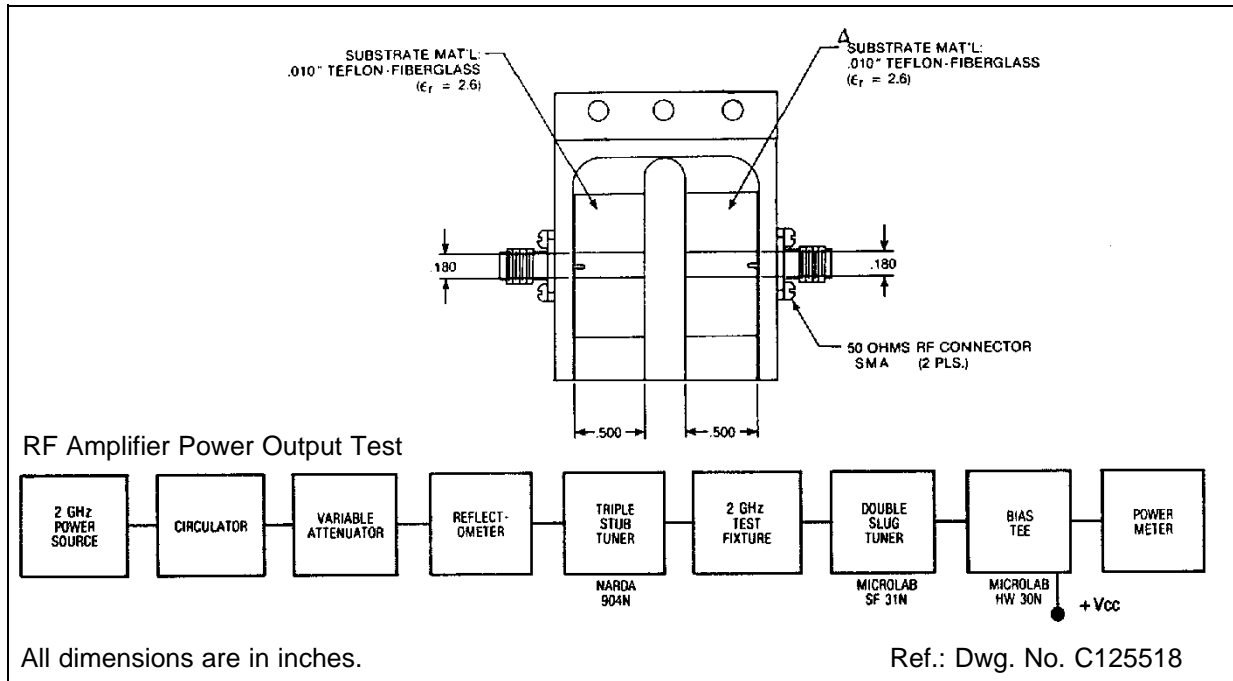

PACKAGE MECHANICAL DATA

Ref.: Dwg. No. 12-0216 rev. A

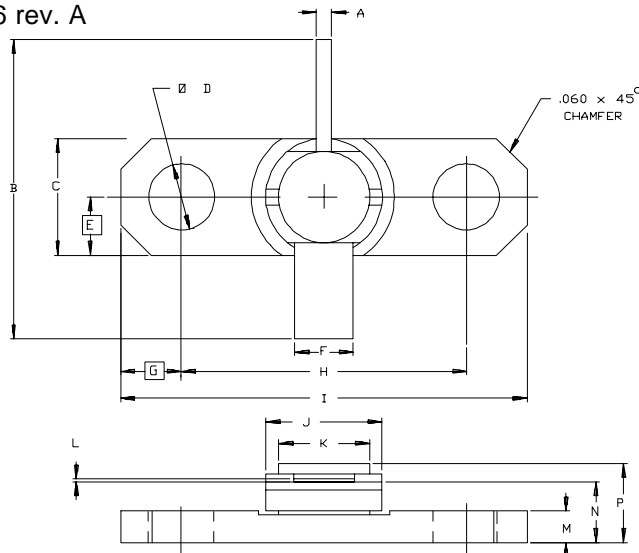

SGS-THOMSON MICROELECTRONICS		CONT'D			
	MINIMUM Inches/mm	MAXIMUM Inches/mm		MINIMUM Inches/mm	MAXIMUM Inches/mm
A	.028/0,71	.032/0,81	K	.165/4,19	.185/4,70
B	.740/18,80		L	.003/0,08	.007/0,18
C	.245/6,22	.255/6,48	M	.058/1,47	.068/1,73
D	.128/3,25	.132/3,35	N	.119/3,02	.135/3,43
E	.125/3,18		P	.149/3,78	.187/4,75
F	.110/2,79	.117/2,97			
G	.117/2,97				
H	.560/14,22	.570/14,48			
I	.795/20,19	.805/20,45			
J	.225/5,72	.235/5,97			

Information furnished is believed to be accurate and reliable. However, SGS-THOMSON Microelectronics assumes no responsibility for the consequences of use of such information nor for any infringement of patents or other rights of third parties which may result from its use. No license is granted by implication or otherwise under any patent or patent rights of SGS-THOMSON Microelectronics. Specifications mentioned in this publication are subject to change without notice. This publication supersedes and replaces all information previously supplied. SGS-THOMSON Microelectronics products are not authorized for use as critical components in life support devices or systems without express written approval of SGS-THOMSON Microelectronics.

©1994 SGS-THOMSON Microelectronics - All Rights Reserved

SGS-THOMSON Microelectronics GROUP OF COMPANIES  
 Australia - Brazil - France - Germany - Hong Kong - Italy - Japan - Korea - Malaysia - Malta - Morocco - The Netherlands -  
 Singapore - Spain - Sweden - Switzerland - Taiwan - Thailand - United Kingdom - U.S.A.