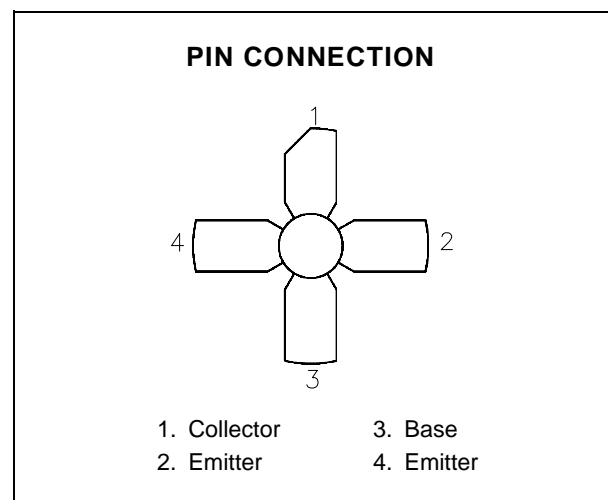
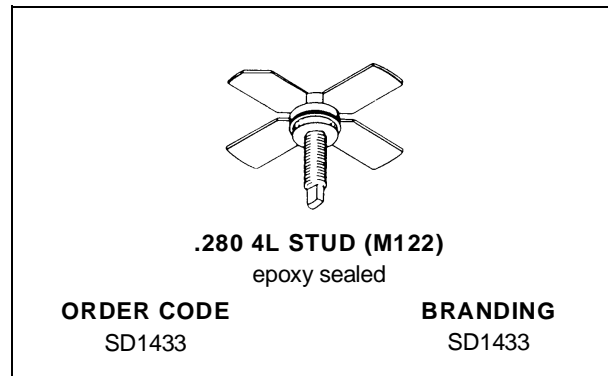

**RF & MICROWAVE TRANSISTORS  
UHF MOBILE APPLICATIONS**

- 470 MHz
- 12.5 VOLTS
- CLASS C
- EFFICIENCY 60%
- COMMON EMITTER
- P<sub>OUT</sub> = 10 W MIN. WITH 8.0 dB GAIN

**DESCRIPTION**

The SD1433 is a Class C epitaxial silicon NPN planar transistor designed for driver applications in the 450 - 512 MHz frequency range. This device uses an emitter ballasted geometry specifically designed for optimum stable power gain, maximum efficiency and infinite VSWR.

**ABSOLUTE MAXIMUM RATINGS** (T<sub>case</sub> = 25°C)

Symbol	Parameter	Value	Unit
V <sub>CBO</sub>	Collector-Base Voltage	36	V
V <sub>CEO</sub>	Collector-Emitter Voltage	16	V
V <sub>CES</sub>	Collector-Emitter Voltage	36	V
V <sub>EBO</sub>	Emitter-Base Voltage	4.0	V
I <sub>c</sub>	Device Current	2.5	A
P <sub>DISS</sub>	Power Dissipation	58	W
T <sub>J</sub>	Junction Temperature	+200	°C
T <sub>STG</sub>	Storage Temperature	- 65 to +150	°C

**THERMAL DATA**

R <sub>TH(j-c)</sub>	Junction-Case Thermal Resistance	3.0	°C/W
----------------------	----------------------------------	-----	------

# SD1433

## ELECTRICAL SPECIFICATIONS (T<sub>case</sub> = 25°C)

### STATIC

Symbol	Test Conditions		Value			Unit
			Min.	Typ.	Max.	
BV <sub>CES</sub>	I <sub>C</sub> = 25mA	V <sub>BE</sub> = 0V	36	—	—	V
BV <sub>CEO</sub>	I <sub>C</sub> = 20mA	I <sub>B</sub> = 0mA	16	—	—	V
BV <sub>EBO</sub>	I <sub>E</sub> = 10mA	I <sub>C</sub> = 0mA	4.0	—	—	V
I <sub>CES</sub>	V <sub>CE</sub> = 10V	I <sub>E</sub> = 0mA	—	—	3	mA
I <sub>CBO</sub>	V <sub>CB</sub> = 15V	I <sub>E</sub> = 0mA	—	—	2	mA
h <sub>FE</sub>	V <sub>CE</sub> = 5V	I <sub>C</sub> = 1A	10	—	—	—

### DYNAMIC

Symbol	Test Conditions			Value			Unit
				Min.	Typ.	Max.	
P <sub>OUT</sub>	f = 470 MHz	P <sub>IN</sub> = 2.0 W	V <sub>CE</sub> = 12.5 V	10	—	—	W
G <sub>P</sub>	f = 470 MHz	P <sub>OUT</sub> = 10 W	V <sub>CE</sub> = 12.5 V	7	—	—	dB
C <sub>OB</sub>	f = 1 MHz	V <sub>CB</sub> = 12.5 V		—	19	—	pF

### TYPICAL PERFORMANCE

#### POWER OUTPUT vs POWER INPUT

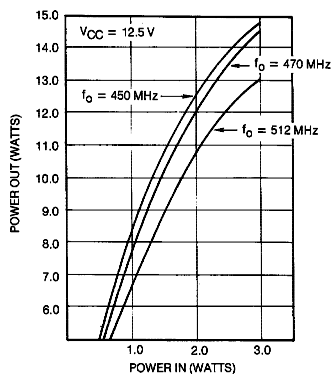

POWER OUT VS POWER IN

#### POWER GAIN & EFFICIENCY vs POWER INPUT

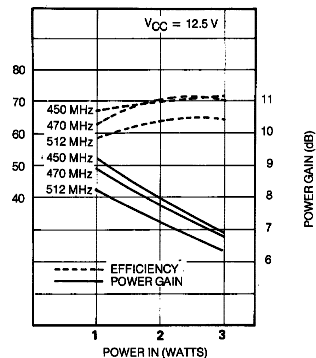

POWER GAIN/EFFICIENCY vs POWER IN

#### POWER OUTPUT vs FREQUENCY

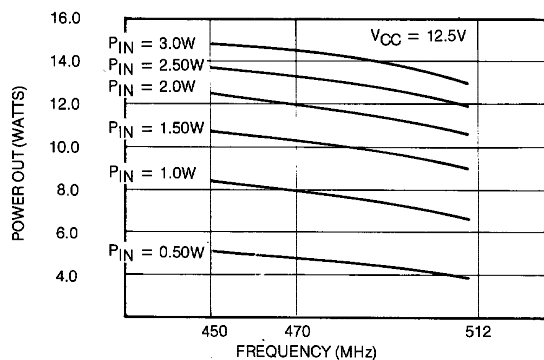

POWER OUT VS FREQUENCY

## IMPEDANCE DATA

## TYPICAL INPUT IMPEDANCE

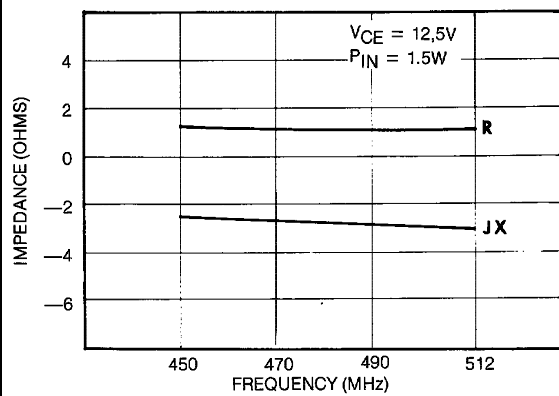

## SERIES SOURCE IMPEDANCE VS FREQUENCY

FREQ.	$Z_{IN}$ ( $\Omega$ )	$Z_{CL}$ ( $\Omega$ )
470 MHz	$1.5 - j 2.7$	$5.7 + j 1.5$

## TYPICAL COLLECTOR LOAD IMPEDANCE

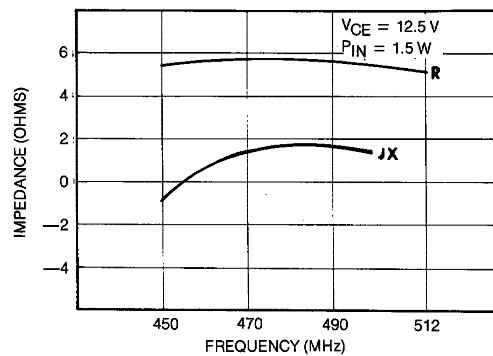

## SERIES COLLECTOR LOAD IMPEDANCE VS FREQUENCY

TEST CIRCUIT

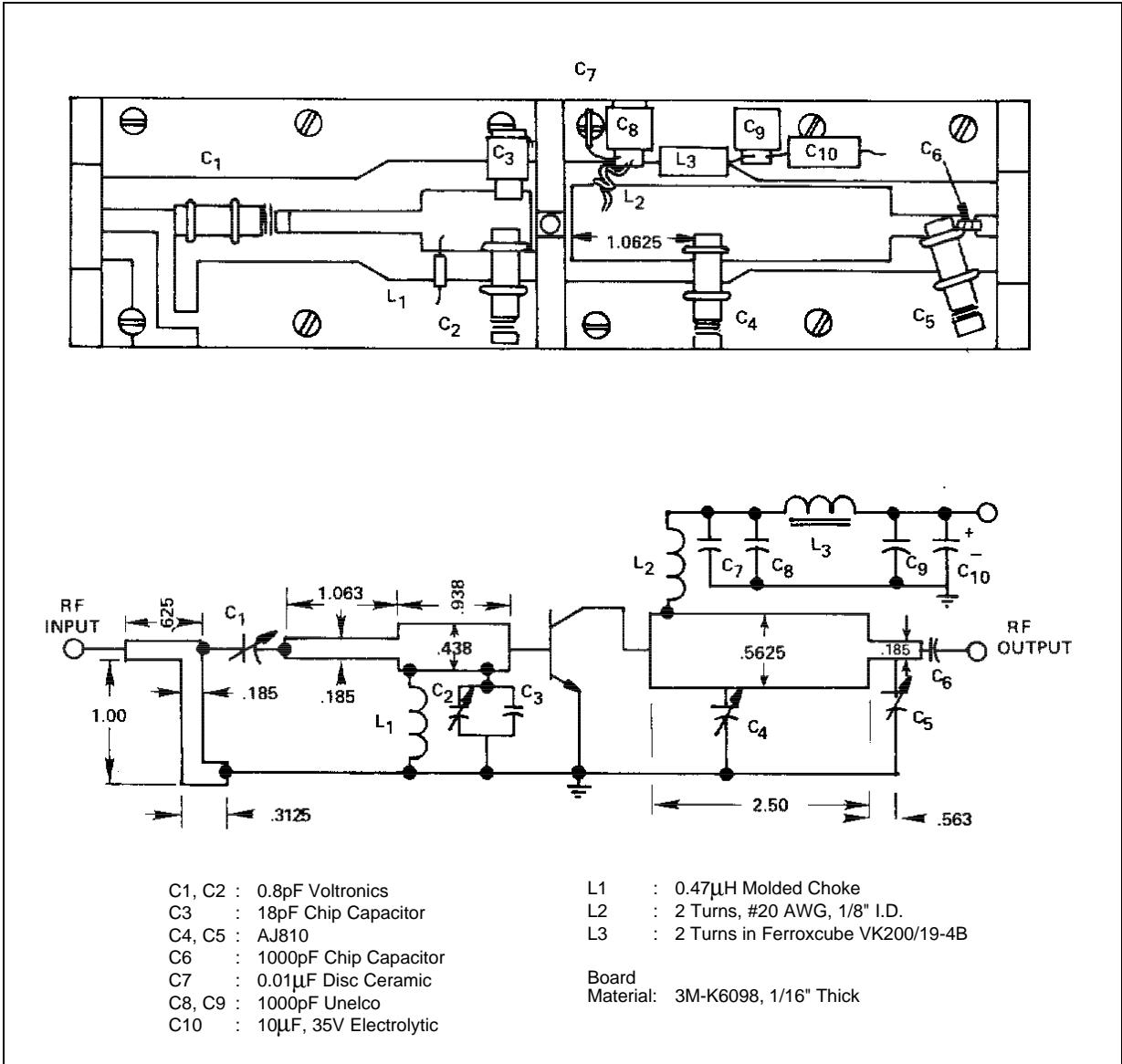

## PACKAGE MECHANICAL DATA

Ref.: Dwg. No.12-0122

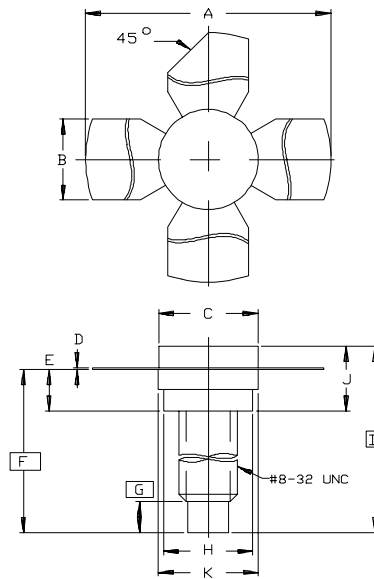

SGS-THOMSON MICROELECTRONICS		
	MINIMUM Inches/mm	MAXIMUM Inches/mm
A	1.010/25,65	1.055/26,80
B	.220/5,59	.230/5,84
C	.270/6,86	.285/7,24
D	.003/0,08	.007/0,18
E	.117/2,97	.137/3,48
F	.572/14,53	
G	.130/3,30	
H	.245/6,22	.255/6,48
I	.640/16,26	
J	.175/4,45	.217/5,51
K	.275/6,99	.285/7,24

Information furnished is believed to be accurate and reliable. However, SGS-THOMSON Microelectronics assumes no responsibility for the consequences of use of such information nor for any infringement of patents or other rights of third parties which may result from its use. No license is granted by implication or otherwise under any patent or patent rights of SGS-THOMSON Microelectronics. Specifications mentioned in this publication are subject to change without notice. This publication supersedes and replaces all information previously supplied. SGS-THOMSON Microelectronics products are not authorized for use as critical components in life support devices or systems without express written approval of SGS-THOMSON Microelectronics.

© 1994 SGS-THOMSON Microelectronics - All Rights Reserved

SGS-THOMSON Microelectronics GROUP OF COMPANIES  
 Australia - Brazil - France - Germany - Hong Kong - Italy - Japan - Korea - Malaysia - Malta - Morocco - The Netherlands -  
 Singapore - Spain - Sweden - Switzerland - Taiwan - Thailand - United Kingdom - U.S.A