



ST3243E

±15KV ESD PROTECTED 3 TO 5.5V, 400KBPS, RS-232 TRANSCEIVER WITH AUTO-POWERDOWN

- ESD PROTECTION FOR RS-232 I/O PINS:
±8KV IEC 1000-4-2 CONTACT DISCHARGE
±15KV HUMAN BODY MODEL
- 1µA SUPPLY CURRENT ACHIEVED WHEN
IN AUTO-POWERDOWN
- 250Kbps MINIMUM GUARANTEED DATA
RATE
- GUARANTEED 6V/µs SLEW RATE RANGE
- GUARANTEED MOUSE DRIVEABILITY
- 0.1µF EXTERNAL CAPACITORS
- MEET EIA/TIA-232 SPECIFICATIONS DOWN
TO 3V
- AVAILABLE IN SO-28, SSOP-28, TSSOP28
AND FLIP-CHIP28 PACKAGES

DESCRIPTION

The ST3243E device consists of 3 drivers, 5 receivers and a dual charge-pump circuit. The device meets the requirements of EIA/TIA and V.28/V.24 communication standards providing high data rate capability and enhanced electrostatic discharge (ESD) protection. All transmitter outputs and receiver input are protected to ±8KV USING IEC 1000-4-2 contact discharge and ±15KV using the Human Body Model. The receiver R2 is always active to implement a wake-up feature for serial port.

The ST3243E has a proprietary low-dropout transmitter output stage enabling true RS-232 performance from a 3.0V to 5.5V supply with a dual charge pump. The device is guaranteed to run at data rates of 250kbps while maintaining RS-232 output levels.

The Auto-powerdown feature functions when FORCEON is low and FORCEOFF is high. During this mode of operation, if the device does not sense a valid RS-232 signal, the driver outputs are

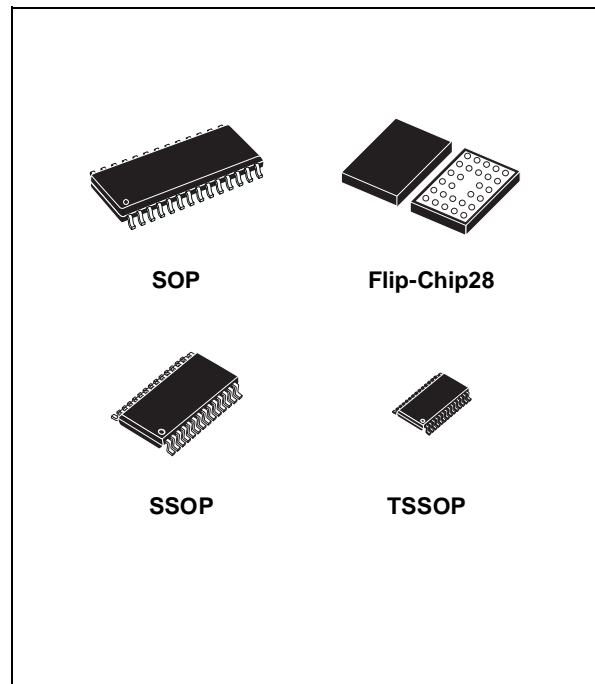

disabled. If FORCEOFF is set low, both drivers and receivers (except R2B) are shut off, and supply current is reduced to 1µA. Disconnecting the serial port or turning off the peripheral drives causes the auto-powerdown condition to occur.

Auto-powerdown can be disabled when FORCEON and FORCEOFF are high, and should be done when driving a serial mouse. With Auto-powerdown enabled, the device is activated automatically when a valid signal is applied to any receiver input.

Typical application are in notebook, subnotebook, palmtop computers, battery-powered equipment, hand-held equipment, peripherals and printers.

ST3243E

ORDERING CODES

Type	Temperature Range	Package	Comments
ST3243ECD	0 to 70 °C	SO-28 (Tube)	27parts per tube / 12tube per box
ST3243EBD	-40 to 85 °C	SO-28 (Tube)	27parts per tube / 12tube per box
ST3243ECDR	0 to 70 °C	SO-28 (Tape & Reel)	1000 parts per reel
ST3243EBDR	-40 to 85 °C	SO-28 (Tape & Reel)	1000 parts per reel
ST3243ECPR	0 to 70 °C	SSOP-28 (Tape & Reel)	1350 parts per reel
ST3243EBPR	-40 to 85 °C	SSOP-28 (Tape & Reel)	1350 parts per reel
ST3243ECTR	0 to 70 °C	TSSOP28 (Tape & Reel)	2500 parts per reel
ST3243EBTR	-40 to 85 °C	TSSOP28 (Tape & Reel)	2500 parts per reel
ST3243ECJ	0 to 70 °C	FLIP-CHIP28	coming soon
ST3243EBJ	-40 to 85 °C	FLIP-CHIP28	coming soon

PIN DESCRIPTION

PIN N°	SYMBOL	NAME AND FUNCTION
1	C ₂₊	Positive Terminal of Inverting Charge Pump Capacitor
2	C ₂₋	Negative Terminal of Inverting Charge Pump Capacitor
3	V-	-5.5V Generated by the Charge Pump
4	R1 _{IN}	First Receiver Input Voltage
5	R2 _{IN}	Second Receiver Input Voltage
6	R3 _{IN}	Third Receiver Input Voltage
7	R4 _{IN}	Fourth Receiver Input Voltage
8	R5 _{IN}	Fifth Receiver Input Voltage
9	T1 _{OUT}	First Transmitter Output Voltage
10	T2 _{OUT}	Second Transmitter Output Voltage
11	T3 _{OUT}	Third Transmitter Output Voltage
12	T3 _{IN}	Third Transmitter Input Voltage
13	T2 _{IN}	Second Transmitter Input Voltage
14	T1 _{IN}	First Transmitter Input Voltage
15	R5 _{OUT}	Fifth Receiver Output Voltage
16	R4 _{OUT}	Fourth Receiver Output Voltage
17	R3 _{OUT}	Third Receiver Output Voltage
18	R2 _{OUT}	Second Receiver Output Voltage
19	R1 _{OUT}	First Receiver Output Voltage
20	R2 _{OUTB}	Non-inverting Complementary Receiver Output, always active for wake-up
21	INVALID	Output of the valid signal detector. Indicates if a valid RS-232 level is present on receiver inputs logic "1"
22	FORCEOFF	Drive low to shut down transmitters and on-board power supply. This over-rides all automatic circuitry and FORCEON
23	FORCEON	Drive high to override automatic circuitry keeping transmitters on (FORCEOFF must be high)
24	C ₁₋	Negative Terminal of Voltage- Charge Pump Capacitor
25	GND	Ground
26	V _{CC}	Supply Voltage
27	V+	5.5V Generated by the Charge Pump
28	C ₁₊	Positive Terminal of Voltage- Charge Pump Capacitor

PIN DESCRIPTION

PIN N°	SYMBOL	NAME AND FUNCTION
A1	R2 _{IN}	Second Receiver Input Voltage
A2	R3 _{IN}	Third Receiver Input Voltage
A3	R4 _{IN}	Fourth Receiver Input Voltage
A4	R5 _{IN}	Fifth Receiver Input Voltage
A5	T1 _{OUT}	First Transmitter Output Voltage
A6	T2 _{OUT}	Second Transmitter Output Voltage
B1	V-	-5.5V Generated by the Charge Pump
B2	R1 _{IN}	First Receiver Input Voltage
B3	T3 _{OUT}	Third Transmitter Output Voltage
B4	T3 _{IN}	Third Transmitter Input Voltage
B5	T1 _{IN}	First Transmitter Input Voltage
B6	T2 _{IN}	Second Transmitter Input Voltage
C1	C ₂₊	Positive Terminal of Inverting Charge Pump Capacitor
C2	C ₂₋	Negative Terminal of Inverting Charge Pump Capacitor
C5	R4 _{OUT}	Fourth Receiver Output Voltage
C6	R5 _{OUT}	Fifth Receiver Output Voltage
D1	C ₁₊	Positive Terminal of Voltage- Charge Pump Capacitor
D2	V+	5.5V Generated by the Charge Pump
D3	V _{CC}	Supply Voltage
D4	FORCEON	Drive high to override automatic circuitry keeping transmitters on (FORCEOFF must be high)
D5	R1 _{OUT}	First Receiver Output Voltage
D6	R3 _{OUT}	Third Receiver Output Voltage
E1	GND	Ground
E2	C ₁₋	Negative Terminal of Voltage- Charge Pump Capacitor
E3	FORCEOFF	Drive low to shut down transmitters and on-board power supply. This over-rides all automatic circuitry and FORCEON
E4	INVALID	Output of the valid signal detector. Indicates if a valid RS-232 level is present on receiver inputs logic "1"
E5	R2 _{OUTB}	Non-inverting Complementary Receiver Output, always active for wake-up
E6	R2 _{OUT}	Second Receiver Output Voltage

PIN CONFIGURATION

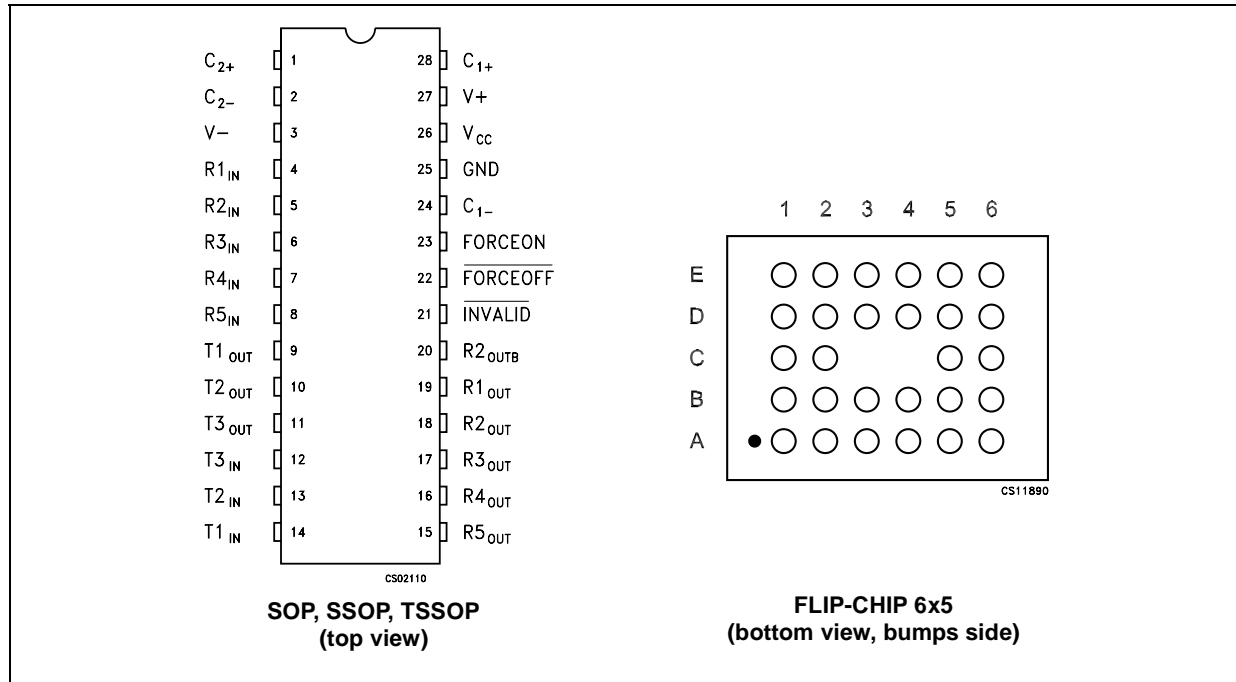

INVALID TRUTH TABLE

RS-232 SIGNAL PRESENT AT ANY RECEIVER INPUT	INVALID OUTPUT
YES	H
NO	L

OUTPUT CONTROL TRUTH TABLE

FORCE ON	FORCE OFF	VALID RECEIVER LEVEL	OPERATION STATUS	T _{OUT}	R _{OUT}	R _{2OUTB}
X	0	X	Shutdown (Force OFF)	HIGH Z	HIGH Z	ACTIVE
1	1	X	Normal Operating (Force ON)	ACTIVE	ACTIVE	ACTIVE
0	1	YES	Normal Operating (Auto-powerdown)	ACTIVE	ACTIVE	ACTIVE
0	1	NO	Shutdown (Auto-powerdown)	HIGH Z	ACTIVE	ACTIVE

ABSOLUTE MAXIMUM RATINGS

Symbol	Parameter	Value	Unit
V_{CC}	Supply Voltage	-0.3 to 6	V
V+	Doubled Voltage Terminal	$(V_{CC} - 0.3)$ to 7	V
V-	Inverted Voltage Terminal	0.3 to -7	V
$V+ + V- $		13	V
FORCEON, FORCEOFF, T_{IN}	Input Voltage	-0.3 to 6	V
R_{IN}	Receiver Input Voltage Range	± 25	V
T_{OUT}	Transmitter Output Voltage Range	± 13.2	V
R_{OUT} R_{OUTB} INVALID	Receiver Output Voltage Range	-0.3 to $(V_{CC} + 0.3)$	V
t_{SHORT}	Short Circuit Duration on T_{OUT} (one at a time)	Continuous	
T_{stg}	Storage Temperature Range	-65 to 150	°C

Absolute Maximum Ratings are those values beyond which damage to the device may occur. Functional operation under these condition is not implied.

ESD PERFORMANCE: TRANSMITTER OUTPUTS, RECEIVER INPUTS

Symbol	Parameter	Test Conditions	Min.	Typ.	Max.	Unit
ESD	ESD Protection Voltage	Human Body Model	± 15			KV
ESD	ESD Protection Voltage	IEC 1000-4-2 (Contact Discharge)	± 8			KV

ELECTRICAL CHARACTERISTICS

($C_1 - C_4 = 0.1\mu\text{F}$, $V_{CC} = 3\text{V}$ to 5.5V , $T_A = -40$ to 85°C , unless otherwise specified.)

Typical values are referred to $T_A = 25^\circ\text{C}$)

Symbol	Parameter	Test Conditions	Min.	Typ.	Max.	Unit
I_{ASHDN}	Supply Current Auto-powerdown	FORCEOFF = GND FORCEON = V_{CC} All R_{IN} open or grounded		1	10	μA
I_{SUPPLY}	Supply Current	FORCEON = FORCEOFF = V_{CC}		0.3	1	mA
I_{SHDN}	Shutdown Supply Current	FORCEOFF = GND		1	10	μA

LOGIC INPUT ELECTRICAL CHARACTERISTICS

($C_1 - C_4 = 0.1\mu\text{F}$, $V_{CC} = 3\text{V}$ to 5.5V , $T_A = -40$ to 85°C , unless otherwise specified.)

Typical values are referred to $T_A = 25^\circ\text{C}$)

Symbol	Parameter	Test Conditions	Min.	Typ.	Max.	Unit
V_{TIL}	Input Logic Threshold Low	T-IN, FORCEON, FORCEOFF			0.8	V
V_{TIH}	Input Logic Threshold High	T-IN, FORCEON, FORCEOFF	2 2.4			V V
V_{THYS}	Transmitter Input Hysteresis			0.5		V
I_{IL}	Input Leakage Current	T-IN, FORCEON, FORCEOFF		± 0.01	± 1.0	μA
I_{OL}	Output Leakage Current	Receiver Disabled		± 0.05	± 10	μA
V_{OL}	Output Voltage Low	$I_{OUT} = 1.6\text{mA}$			0.4	V
V_{OH}	Output Voltage High	$I_{OUT} = -1\text{mA}$	$V_{CC}-0.6$	$V_{CC}-0.1$		V

AUTO-POWERDOWN ELECTRICAL CHARACTERISTICS(C₁ - C₄ = 0.1μF, V_{CC} = 3V to 5.5V, T_A = -40 to 85°C, unless otherwise specified.Typical values are referred to T_A = 25°C, FORCEON = GND, FORCEOFF = V_{CC})

Symbol	Parameter	Test Conditions	Min.	Typ.	Max.	Unit
V _{RITE}	Receiver Input Threshold to INVALID Output Voltage HIGH (Fig. 1)	Positive Threshold			2.7	V
		Negative Threshold	2.7			V
V _{RITD}	Receiver Input Threshold to INVALID Output Voltage LOW (Fig. 1)		-0.3		0.3	V
V _{IO_L}	INVALID Output Voltage LOW	I _{OUT} = 1.6mA			0.4	V
V _{IO_H}	INVALID Output Voltage HIGH	I _{OUT} = -1mA	V _{CC} -0.6			V
t _{WU}	Receiver or Transmitter Edge Transmitter Enabled (Fig. 1)			100		μs
t _{invh}	Receiver Positive or Negative Threshold to INVALID HIGH (Fig. 1)			0.2		μs
t _{invL}	Receiver Positive or Negative Threshold to INVALID LOW (Fig. 1)			30		μs

TRANSMITTER ELECTRICAL CHARACTERISTICS(C₁ - C₄ = 0.1μF, V_{CC} = 3V to 5.5V, T_A = -40 to 85°C, unless otherwise specified.Typical values are referred to T_A = 25°C)

Symbol	Parameter	Test Conditions	Min.	Typ.	Max.	Unit
V _{TOUT}	Output Voltage Swing	All Transmitter outputs are loaded with 3KΩ to GND	± 5	± 5.4		V
R _{OUT}	Output Resistance	V _{CC} = V+ = V- = 0V V _{OUT} = ± 2V	300	10M		Ω
I _{SC}	Output Short Circuit Current	V _{CC} = 3.3V		± 40	± 60	mA
I _L	Output Leakage Current	V _{CC} = 0 to 5.5V, trasmitter output = ± 12V, trasmitter disabled			± 25	mA
V _{OT}	Transmitter Output Voltage	T1IN = T2IN = GND, T3IN = V _{CC} T3OUT loaded with 3KΩ to GND T1OUT and T2OUT loaded with 2.5mA each	± 5			V

RECEIVER ELECTRICAL CHARACTERISTICS(C₁ - C₄ = 0.1μF, V_{CC} = 3V to 5.5V, T_A = -40 to 85°C, unless otherwise specified.Typical values are referred to T_A = 25°C)

Symbol	Parameter	Test Conditions	Min.	Typ.	Max.	Unit
V _{RIN}	Receiver Input Voltage Operating Range		-25		25	V
V _{RIL}	RS-232 Input Threshold Low	T _A = 25°C V _{CC} = 3.3V	0.6	1.1		V
		T _A = 25°C V _{CC} = 5.0V	0.8	1.4		
V _{RIH}	RS-232 Input Threshold High	T _A = 25°C V _{CC} = 3.3V		1.6	2.4	V
		T _A = 25°C V _{CC} = 5.0V		1.9	2.4	
V _{RIHYS}	Input Hysteresis			0.5		V
R _{RIN}	Input Resistance	T _A = 25°C	3	5	7	KΩ

TIMING CHARACTERISTICS

($C_1 - C_4 = 0.1\mu\text{F}$, $V_{CC} = 3\text{V to } 5.5\text{V}$, $T_A = -40 \text{ to } 85^\circ\text{C}$, unless otherwise specified.)

Typical values are referred to $T_A = 25^\circ\text{C}$)

Symbol	Parameter	Test Conditions	Min.	Typ.	Max.	Unit
D_R	Maximum Data Rate	$R_L = 3\text{K}\Omega$ $C_L = 1000\text{pF}$ one transmitter switching	250	400		Kbps
t_{PHL} t_{PLH}	Receiver Propagation Delay	R_{IN} to R_{OUT} $C_L = 150\text{pF}$		0.15		μs
t_{T_SKEW}	Transmitter Skew			150		ns
t_{R_SKEW}	Receiver Skew			70		ns
S_{RT}	Transition Slew Rate	$T_A = 25^\circ\text{C}$ $R_L = 3\text{K to } 7\text{K}\Omega$ $V_{CC} = 3.3\text{V}$ measured from +3V to -3V or -3V to +3V $C_L = 150\text{pF to } 1000\text{pF}$ $C_L = 150\text{pF to } 2500\text{pF}$	6 4		30 30	$\text{V}/\mu\text{s}$ $\text{V}/\mu\text{s}$

APPLICATION CIRCUITS

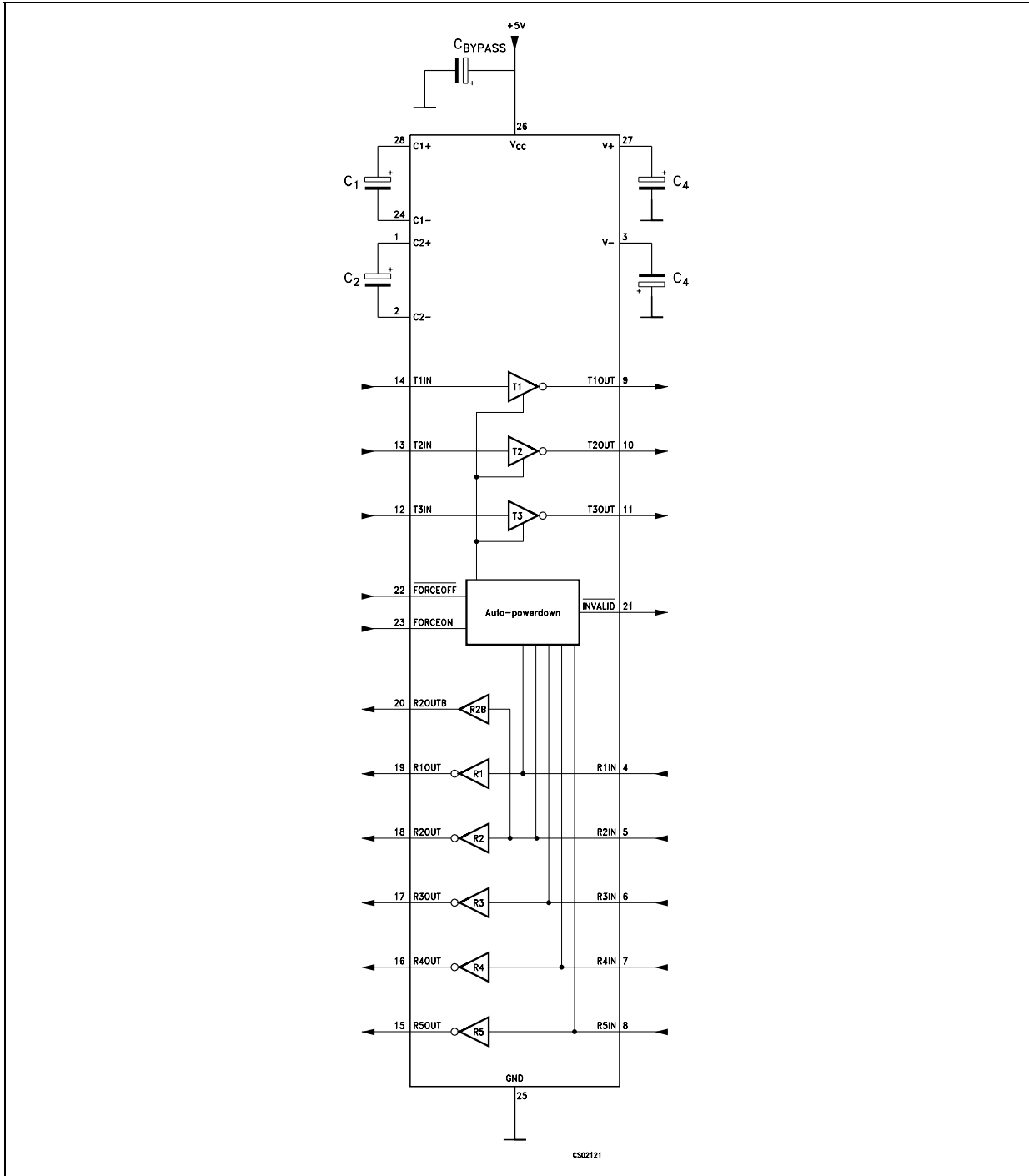

REQUIRED MINIMUM CAPACITANCE VALUE (μF)

V _{CC} (V)	C ₁	C ₂ , C ₃ , C ₄ , C _{BYPASS}
3 to 3.6	0.1	0.1
4.5 to 5.5	0.047	0.33

AUTOPOWERDOWN INPUT LEVELS

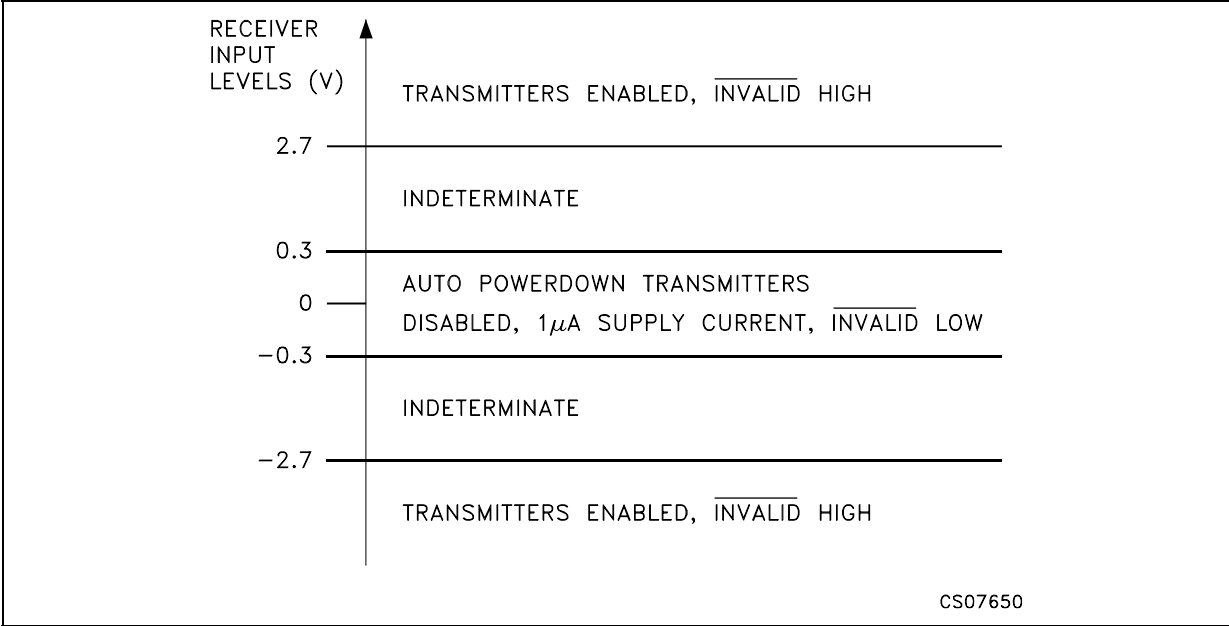

AUTOPOWERDOWN INPUT TIMING

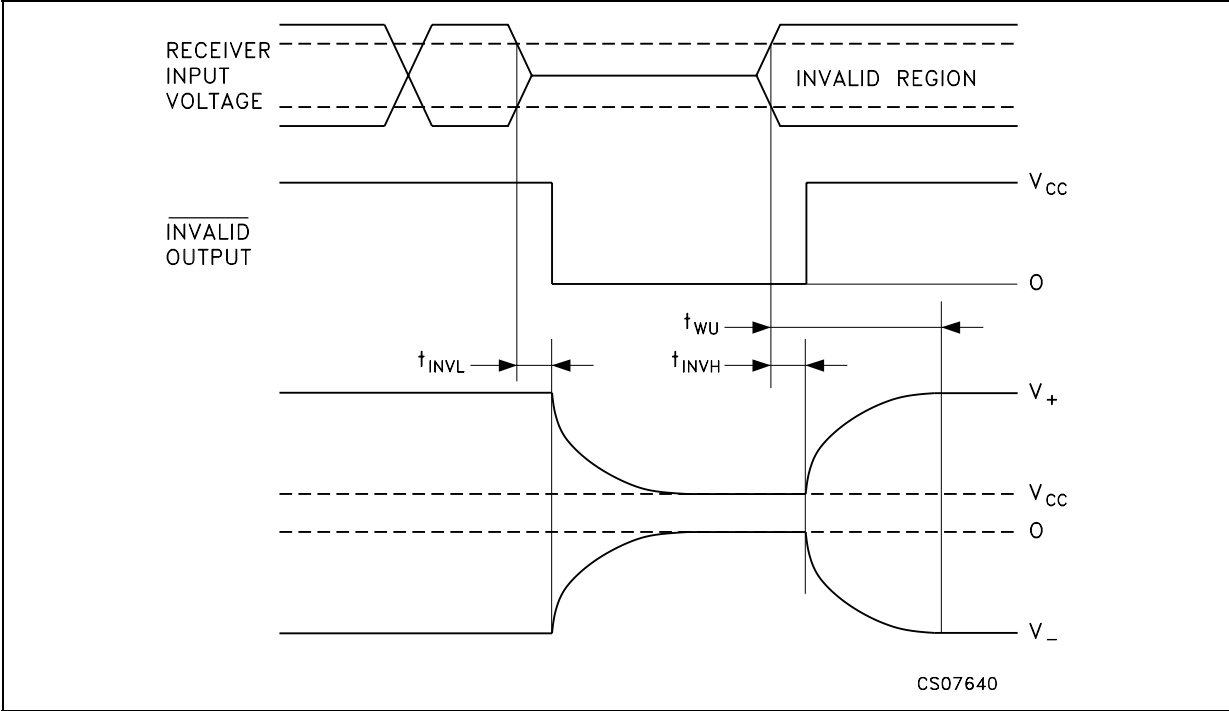

SO-28 MECHANICAL DATA

DIM.	mm.			inch		
	MIN.	TYP	MAX.	MIN.	TYP.	MAX.
A			2.65			0.104
a1	0.1		0.3	0.004		0.012
b	0.35		0.49	0.014		0.019
b1	0.23		0.32	0.009		0.012
C		0.5			0.020	
c1	45° (typ.)					
D	17.70		18.10	0.697		0.713
E	10.00		10.65	0.393		0.419
e		1.27			0.050	
e3		16.51			0.650	
F	7.40		7.60	0.291		0.300
L	0.50		1.27	0.020		0.050
S	8° (max.)					

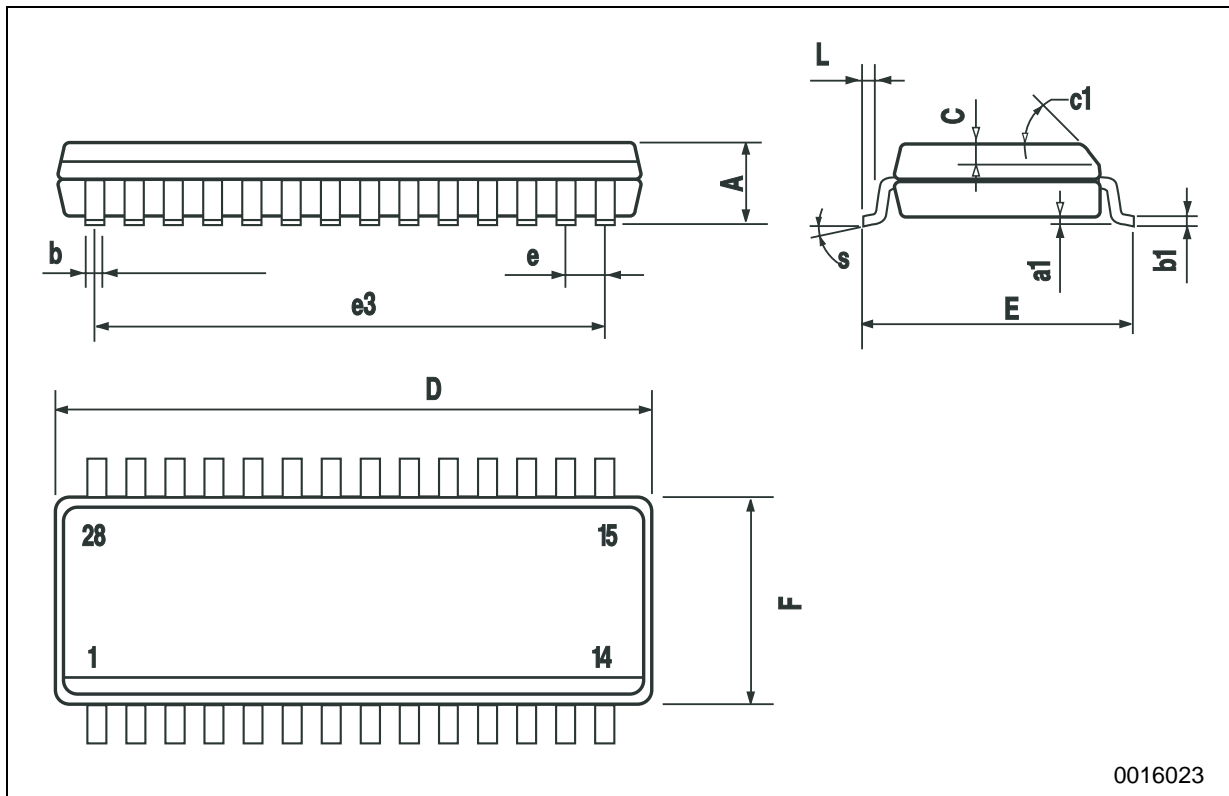

0016023

SSOP28 MECHANICAL DATA

DIM.	mm.			inch		
	MIN.	TYP	MAX.	MIN.	TYP.	MAX.
A			2			0.079
A1	0.050			0.002		
A2	1.65	1.75	1.85	0.065	0.069	0.073
b	0.22		0.38	0.009		0.015
c	0.09		0.25	0.004		0.010
D	9.9	10.2	10.5	0.390	0.402	0.413
E	7.4	7.8	8.2	0.291	0.307	0.323
E1	5	5.3	5.6	0.197	0.209	0.220
e		0.65 BSC			0.0256 BSC	
K	0°		10°	0°		10°
L	0.55	0.75	0.95	0.022	0.030	0.037

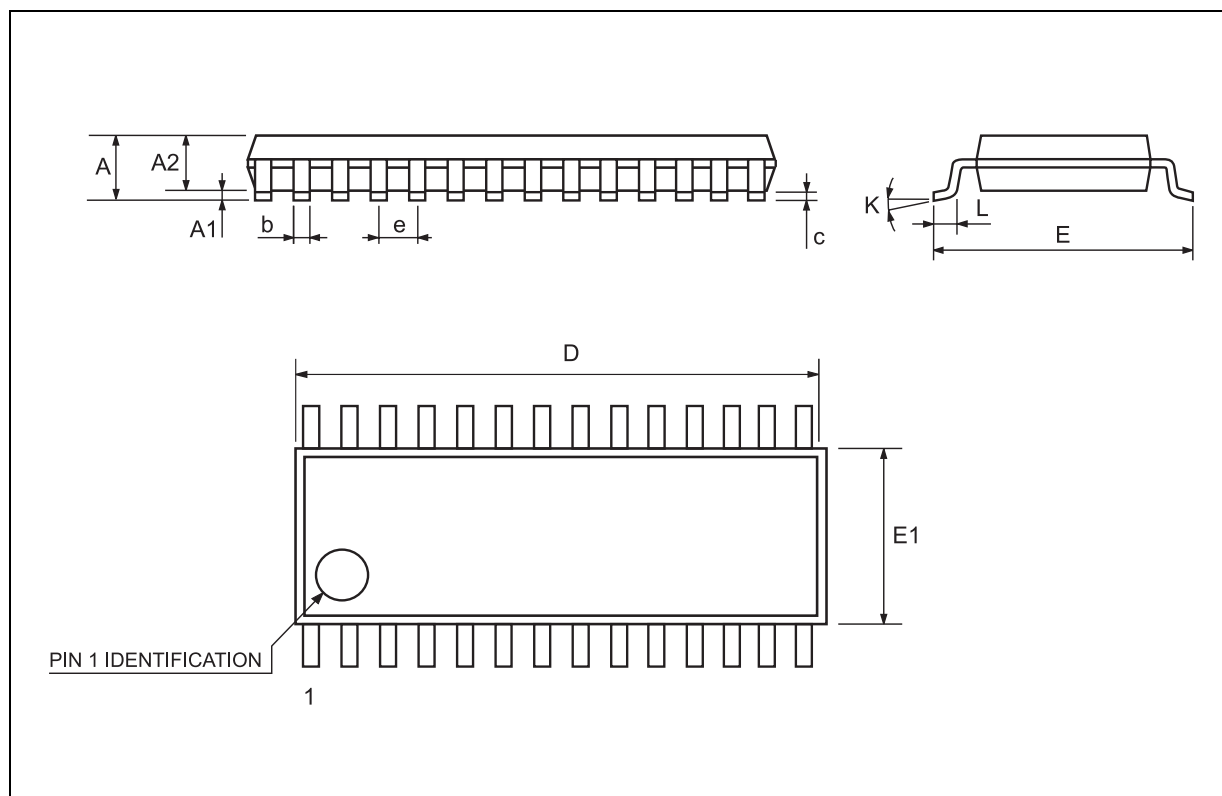

TSSOP28 MECHANICAL DATA

DIM.	mm.			inch		
	MIN.	TYP	MAX.	MIN.	TYP.	MAX.
A			1.2			0.047
A1	0.05		0.15	0.002	0.004	0.006
A2	0.8	1	1.05	0.031	0.039	0.041
b	0.19		0.30	0.007		0.012
c	0.09		0.20	0.004		0.0079
D	9.6	9.7	9.8	0.378	0.382	0.386
E	6.2	6.4	6.6	0.244	0.252	0.260
E1	4.3	4.4	4.48	0.169	0.173	0.176
e		0.65 BSC			0.0256 BSC	
K	0°		8°	0°		8°
L	0.45	0.60	0.75	0.018	0.024	0.030

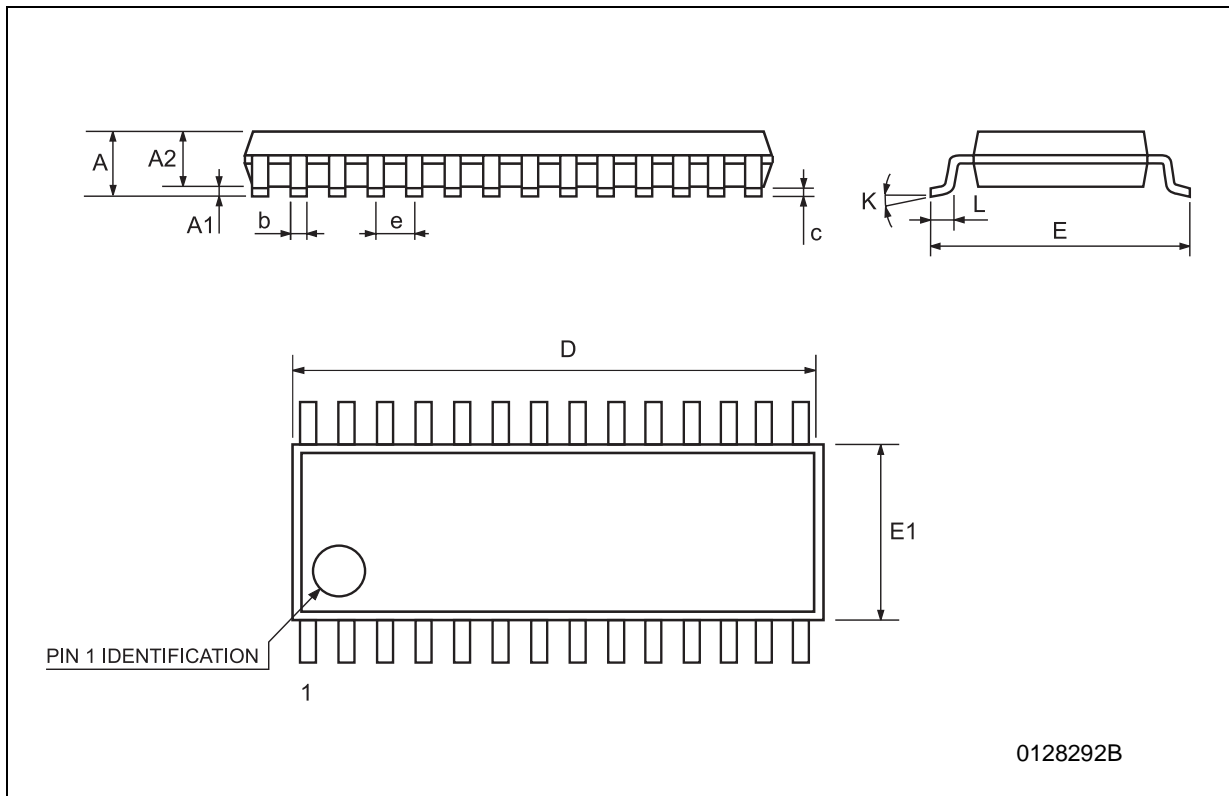

Flip-Chip28 MECHANICAL DATA

DIM.	mm.			mils		
	MIN.	TYP	MAX.	MIN.	TYP.	MAX.
A	0.58		0.95	22.8		37.4
A1		0.24			9.4	
A2		0.65			25.6	
b	0.25	0.30	0.35	9.8	11.8	13.8
D	3.97		4.17	156.3		164.2
D1		2.5			98.4	
E	2.47		2.67	97.2		105.1
E1		2			78.7	
e	0.45		0.55	17.7		21.7
f	0.23		0.34	9.1		13.4
f1	0.80		0.91	31.5		31.8

BOTTOM VIEW (BUMPS SIDE)

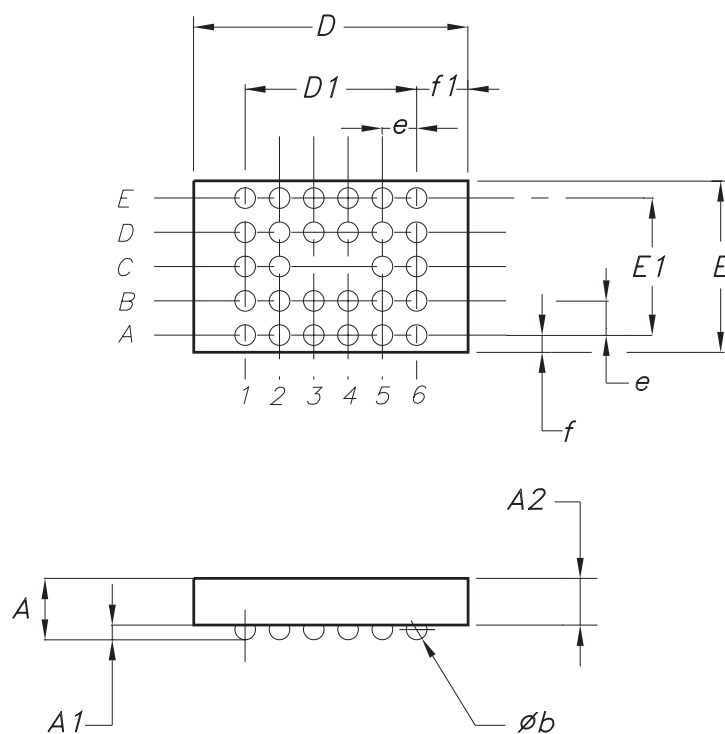

Information furnished is believed to be accurate and reliable. However, STMicroelectronics assumes no responsibility for the consequences of use of such information nor for any infringement of patents or other rights of third parties which may result from its use. No license is granted by implication or otherwise under any patent or patent rights of STMicroelectronics. Specifications mentioned in this publication are subject to change without notice. This publication supersedes and replaces all information previously supplied. STMicroelectronics products are not authorized for use as critical components in life support devices or systems without express written approval of STMicroelectronics.

© The ST logo is a registered trademark of STMicroelectronics

© 2002 STMicroelectronics - Printed in Italy - All Rights Reserved
STMicroelectronics GROUP OF COMPANIES

Australia - Brazil - Canada - China - Finland - France - Germany - Hong Kong - India - Israel - Italy - Japan - Malaysia - Malta - Morocco
Singapore - Spain - Sweden - Switzerland - United Kingdom - United States.

© <http://www.st.com>