



STBV45

HIGH VOLTAGE FAST-SWITCHING NPN POWER TRANSISTOR

- MEDIUM VOLTAGE CAPABILITY
- LOW SPREAD OF DYNAMIC PARAMETERS
- MINIMUM LOT-TO-LOT SPREAD FOR RELIABLE OPERATION
- VERY HIGH SWITCHING SPEED

APPLICATIONS:

- ELECTRONIC BALLASTS FOR FLUORESCENT LIGHTING

DESCRIPTION

The device is manufactured using high voltage Multi Epitaxial Planar technology for high switching speeds and medium voltage capability. It uses a Cellular Emitter structure with planar edge termination to enhance switching speeds while maintaining the wide RBSOA. The STBV45 is designed for use in compact fluorescent lamp application.

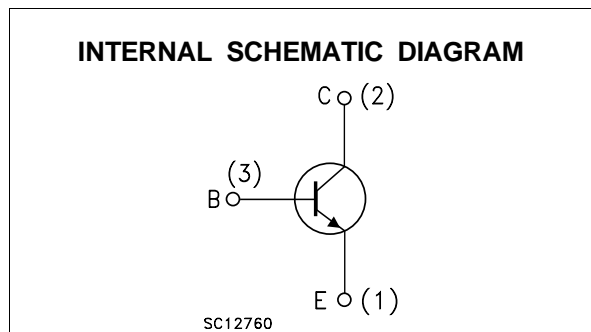
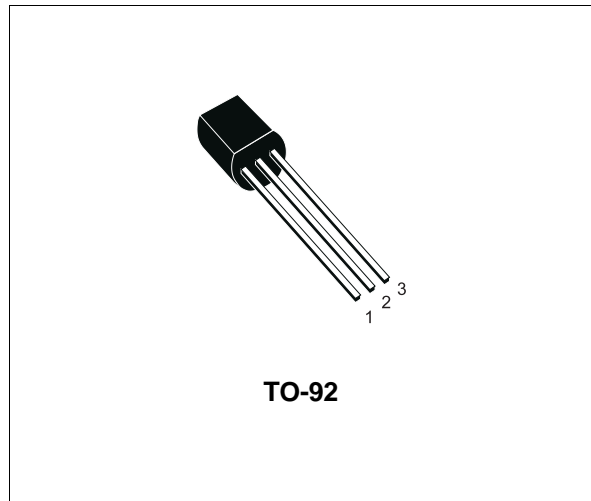

ABSOLUTE MAXIMUM RATINGS

Symbol	Parameter	Value	Unit
V_{CES}	Collector-Emitter Voltage ($V_{BE} = 0$)	600	V
V_{CEO}	Collector-Emitter Voltage ($I_B = 0$)	400	V
V_{EBO}	Emitter-Base Voltage ($I_C = 0$)	9	V
I_C	Collector Current	0.75	A
I_{CM}	Collector Peak Current ($t_p < 5$ ms)	1.5	A
I_B	Base Current	0.4	A
I_{BM}	Base Peak Current ($t_p < 5$ ms)	0.75	A
P_{tot}	Total Dissipation at $T_{amb} = 25$ °C	0.95	W
T_{stg}	Storage Temperature	-65 to 150	°C
T_j	Max. Operating Junction Temperature	150	°C

STBV45

THERMAL DATA

$R_{thj-amb}$	Thermal Resistance Junction-ambient	Max	130	$^{\circ}\text{C}/\text{W}$
---------------	-------------------------------------	-----	-----	-----------------------------

ELECTRICAL CHARACTERISTICS ($T_{case} = 25^{\circ}\text{C}$ unless otherwise specified)

Symbol	Parameter	Test Conditions	Min.	Typ.	Max.	Unit
I_{CEV}	Collector Cut-off Current ($V_{BE} = -1.5\text{V}$)	$V_{CE} = 600\text{ V}$			250	μA
I_{EBO}	Emitter Cut-off Current ($I_C = 0$)	$V_{EB} = 9\text{ V}$			1	mA
$V_{CEO(sus)}^*$	Collector-Emitter Sustaining Voltage ($I_B = 0$)	$I_C = 1\text{ mA}$ $L = 25\text{ mH}$	400			V
$V_{CE(sat)}^*$	Collector-Emitter Saturation Voltage	$I_C = 0.2\text{ A}$ $I_B = 40\text{ mA}$ $I_C = 0.3\text{ A}$ $I_B = 75\text{ mA}$ $I_C = 0.4\text{ A}$ $I_B = 135\text{ mA}$		0.2 0.3 0.4	0.5 1.0 1.5	V V V
$V_{BE(sat)}^*$	Base-Emitter Saturation Voltage	$I_C = 0.2\text{ A}$ $I_B = 40\text{ mA}$ $I_C = 0.3\text{ A}$ $I_B = 75\text{ mA}$			1.0 1.2	V V
h_{FE}^*	DC Current Gain	$I_C = 0.2\text{ A}$ $V_{CE} = 5\text{ V}$ $I_C = 0.4\text{ A}$ $V_{CE} = 5\text{ V}$	10 5		30 20	
t_f	INDUCTIVE LOAD Fall Time	$I_C = 0.2\text{ A}$ $V_{clamp} = 300\text{ V}$ $I_{B1} = -I_{B2} = 40\text{ mA}$ $L = 3\text{ mH}$		0.3		μs

* Pulsed: Pulse duration = 300 μs , duty cycle = 1.5 %

Safe Operating Area

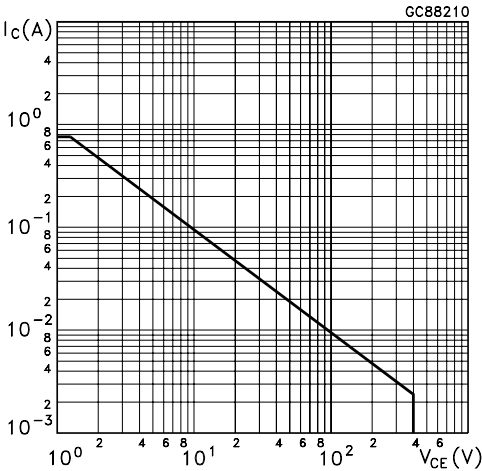

Derating Curve

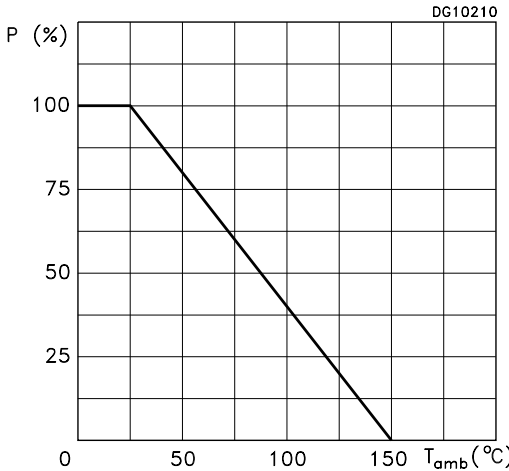

DC Current Gain

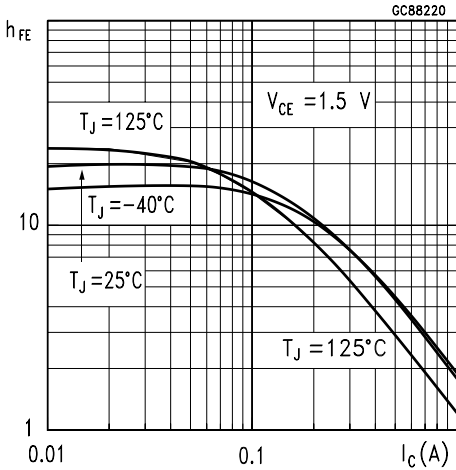

DC Current Gain

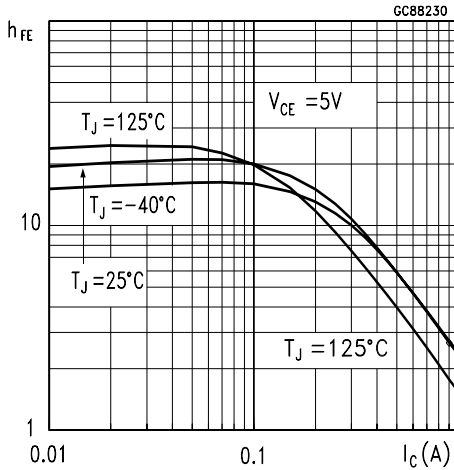

Collector Emitter Saturation Voltage

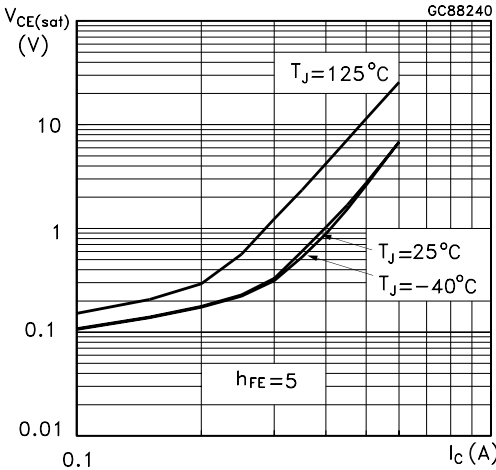

Base Emitter Saturation Voltage

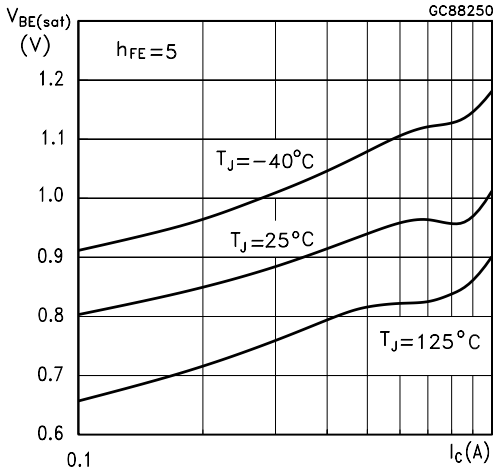

TO-92 MECHANICAL DATA

DIM.	mm			inch		
	MIN.	TYP.	MAX.	MIN.	TYP.	MAX.
A	4.58		5.33	0.180		0.210
B	4.45		5.2	0.175		0.204
C	3.2		4.2	0.126		0.165
D	12.7			0.500		
E		1.27			0.050	
F	0.4		0.51	0.016		0.020
G	0.35			0.14		

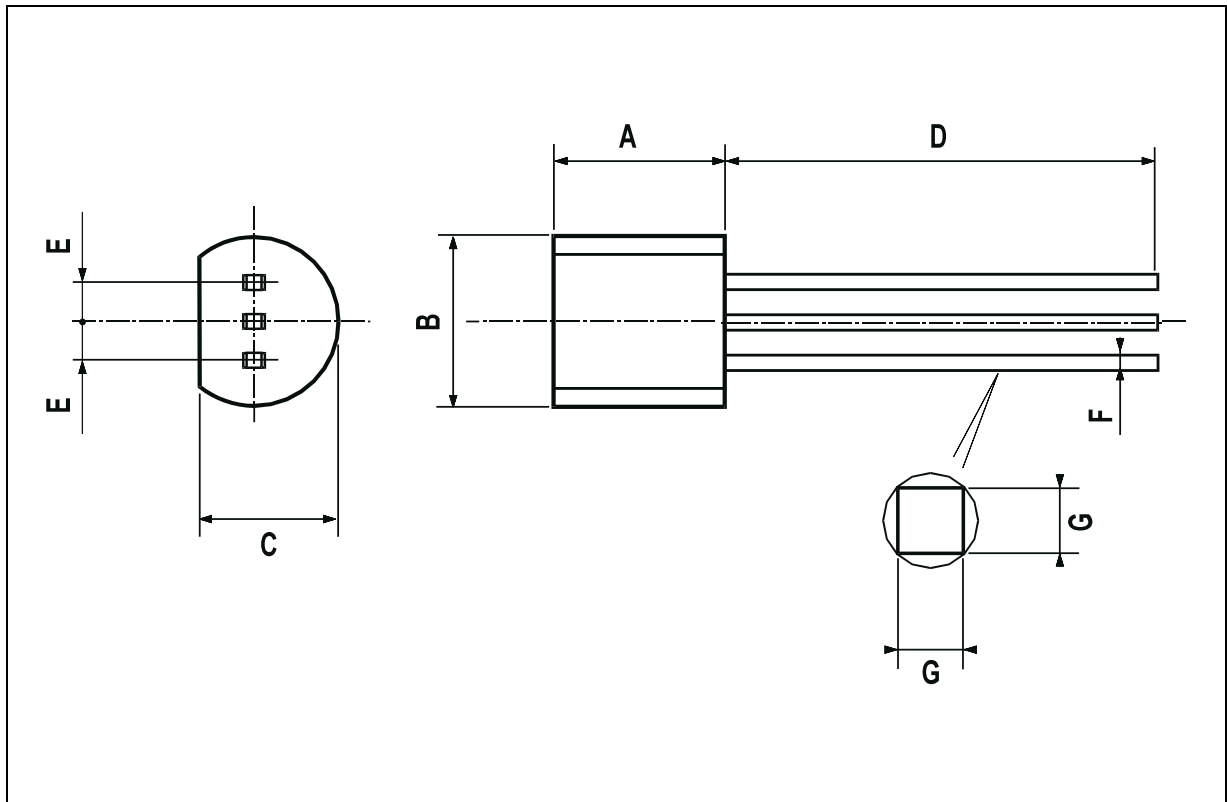

Information furnished is believed to be accurate and reliable. However, STMicroelectronics assumes no responsibility for the consequences of use of such information nor for any infringement of patents or other rights of third parties which may result from its use. No license is granted by implication or otherwise under any patent or patent rights of STMicroelectronics. Specification mentioned in this publication are subject to change without notice. This publication supersedes and replaces all information previously supplied. STMicroelectronics products are not authorized for use as critical components in life support devices or systems without express written approval of STMicroelectronics.

The ST logo is a trademark of STMicroelectronics

© 2000 STMicroelectronics – Printed in Italy – All Rights Reserved

STMicroelectronics GROUP OF COMPANIES

Australia - Brazil - China - Finland - France - Germany - Hong Kong - India - Italy - Japan - Malaysia - Malta - Morocco -
Singapore - Spain - Sweden - Switzerland - United Kingdom - U.S.A.

<http://www.st.com>