



# STC5NF30V

## N-CHANNEL 30V - 0.027 $\Omega$ - 5A TSSOP8 2.7V-DRIVE STripFET™ II POWER MOSFET

TYPE	V <sub>DSS</sub>	R <sub>DS(on)</sub>	I <sub>D</sub>
STC5NF30V	30 V	< 0.031 $\Omega$ ( @ 4.5 V ) < 0.035 $\Omega$ ( @ 2.7 V )	5 A

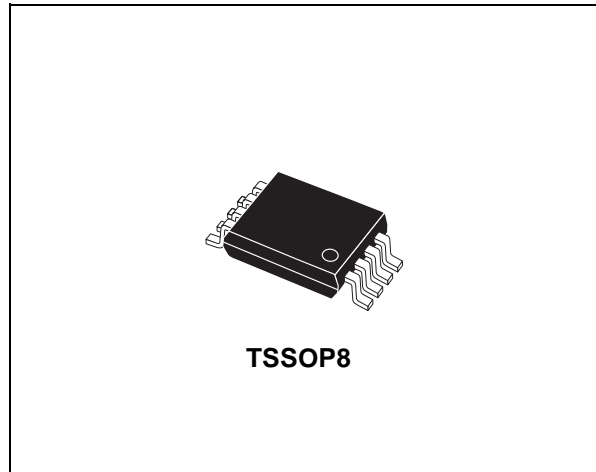
- TYPICAL R<sub>DS(on)</sub> = 0.027  $\Omega$  @ 4.5 V
- TYPICAL R<sub>DS(on)</sub> = 0.031  $\Omega$  @ 2.7 V
- ULTRA LOW THRESHOLD GATE DRIVE (2.7 V)
- STANDARD OUTLINE FOR EASY AUTOMATED SURFACE MOUNT ASSEMBLY

### DESCRIPTION

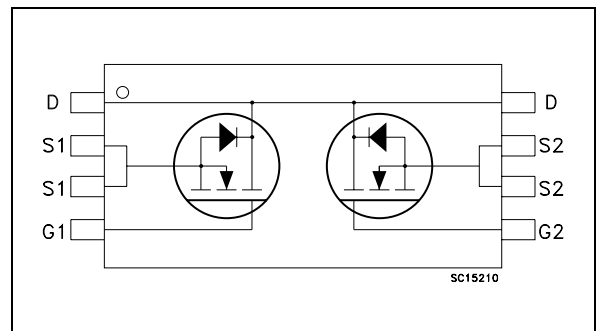
This Power MOSFET is the latest development of STMicroelectronics unique "Single Feature Size™" strip-based process. The resulting transistor shows extremely high packing density for low on-resistance, rugged avalanche characteristics and less critical alignment steps therefore a remarkable manufacturing reproducibility.

### APPLICATIONS

- DC MOTOR DRIVE
- DC-DC CONVERTERS
- BATTERY MANAGEMENT IN NOMADIC EQUIPMENT
- POWER MANAGEMENT IN PORTABLE/DESKTOP PCs



### INTERNAL SCHEMATIC DIAGRAM



### ABSOLUTE MAXIMUM RATINGS

Symbol	Parameter	Value	Unit
V <sub>DS</sub>	Drain-source Voltage (V <sub>GS</sub> = 0)	30	V
V <sub>DGR</sub>	Drain-gate Voltage (R <sub>GS</sub> = 20 k $\Omega$ )	20	V
V <sub>GS</sub>	Gate- source Voltage	$\pm 12$	V
I <sub>D</sub>	Drain Current (continuous) at T <sub>C</sub> = 25°C	5	A
I <sub>D</sub>	Drain Current (continuous) at T <sub>C</sub> = 100°C	3	A
I <sub>DM</sub> (●)	Drain Current (pulsed)	20	A
P <sub>tot</sub>	Total Dissipation at T <sub>C</sub> = 25°C	1.5	W

(●) Pulse width limited by safe operating area.

# STC5NF30V

## THERMAL DATA

Rthj-pcb	Thermal Resistance Junction-PCB (**)	Max	100	°C/W
Rthj-pcb	Thermal Resistance Junction-PCB (*)	Max	83.5	°C/W
T <sub>j</sub>	Operating Junction Temperature		-55 to 150	°C
T <sub>stg</sub>	Storage temperature		-55 to 150	°C

(\*) When Mounted on FR-4 board with 1 inch<sup>2</sup> pad, 2 oz of Cu and t ≤ 10 sec

(\*\*) When Mounted on minimum recommended footprint

## ELECTRICAL CHARACTERISTICS (T<sub>case</sub> = 25 °C unless otherwise specified)

### OFF

Symbol	Parameter	Test Conditions	Min.	Typ.	Max.	Unit
V <sub>(BR)DSS</sub>	Drain-source Breakdown Voltage	I <sub>D</sub> = 250 μA, V <sub>GS</sub> = 0	30			V
I <sub>DSS</sub>	Zero Gate Voltage Drain Current (V <sub>GS</sub> = 0)	V <sub>DS</sub> = Max Rating V <sub>DS</sub> = Max Rating T <sub>C</sub> = 125°C			1 10	μA μA
I <sub>GSS</sub>	Gate-body Leakage Current (V <sub>DS</sub> = 0)	V <sub>GS</sub> = ± 12V			±100	nA

### ON (\*)

Symbol	Parameter	Test Conditions	Min.	Typ.	Max.	Unit
V <sub>GS(th)</sub>	Gate Threshold Voltage	V <sub>DS</sub> = V <sub>GS</sub> I <sub>D</sub> = 250 μA	0.6			V
R <sub>DS(on)</sub>	Static Drain-source On Resistance	V <sub>GS</sub> = 4.5 V I <sub>D</sub> = 2.5 A V <sub>GS</sub> = 2.7 V I <sub>D</sub> = 2.5 A		0.027 0.031	0.031 0.035	Ω Ω

### DYNAMIC

Symbol	Parameter	Test Conditions	Min.	Typ.	Max.	Unit
g <sub>fs</sub> (*)	Forward Transconductance	V <sub>DS</sub> =15 V I <sub>D</sub> = 2.5 A		9.5		S
C <sub>iss</sub>	Input Capacitance	V <sub>DS</sub> = 15V f = 1 MHz, V <sub>GS</sub> = 0		460		pF
C <sub>oss</sub>	Output Capacitance			200		pF
C <sub>rss</sub>	Reverse Transfer Capacitance			50		pF

**ELECTRICAL CHARACTERISTICS** (continued)

**SWITCHING ON**

Symbol	Parameter	Test Conditions	Min.	Typ.	Max.	Unit
$t_{d(on)}$ $t_r$	Turn-on Delay Time Rise Time	$V_{DD} = 10\text{ V}$ $I_D = 2.5\text{ A}$ $R_G = 4.7\ \Omega$ $V_{GS} = 4.5\text{ V}$ (Resistive Load, Figure 1)		7 33		ns ns
$Q_g$ $Q_{gs}$ $Q_{gd}$	Total Gate Charge Gate-Source Charge Gate-Drain Charge	$V_{DD} = 16\text{ V}$ $I_D = 5\text{ A}$ $V_{GS} = 4.5\text{ V}$ (see test circuit, Figure 2)		8.5 1.8 2.4	11.5	nC nC nC

**SWITCHING OFF**

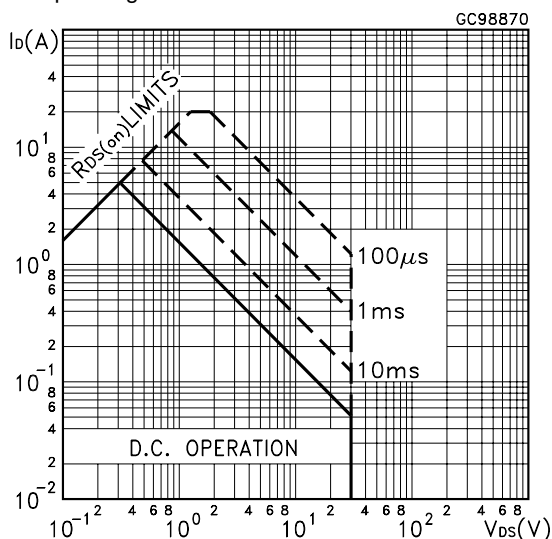
Symbol	Parameter	Test Conditions	Min.	Typ.	Max.	Unit
$t_{d(off)}$ $t_f$	Turn-off Delay Time Fall Time	$V_{DD} = 10\text{ V}$ $I_D = 2.5\text{ A}$ $R_G = 4.7\ \Omega$ , $V_{GS} = 4.5\text{ V}$ (Resistive Load, Figure 1)		27 10		ns ns
$t_{d(Voff)}$ $t_f$ $t_c$	Off-voltage Rise Time Fall Time Cross-over Time	$V_{clamp} = 16\text{ V}$ $I_D = 5\text{ A}$ $R_G = 4.7\ \Omega$ , $V_{GS} = 4.5\text{ V}$ (Inductive Load, Figure 3)		26 11 21		ns ns ns

**SOURCE DRAIN DIODE**

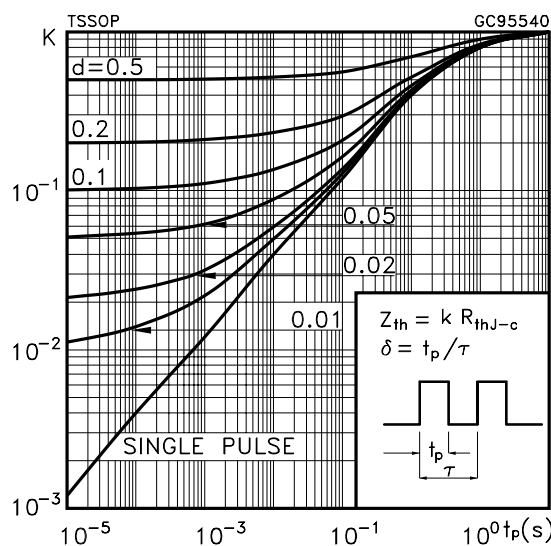
Symbol	Parameter	Test Conditions	Min.	Typ.	Max.	Unit
$I_{SD}$ $I_{SDM} (\bullet)$	Source-drain Current Source-drain Current (pulsed)				5 20	A A
$V_{SD} (*)$	Forward On Voltage	$I_{SD} = 5\text{ A}$ $V_{GS} = 0$			1.2	V
$t_{rr}$ $Q_{rr}$ $I_{RRM}$	Reverse Recovery Time Reverse Recovery Charge Reverse Recovery Current	$I_{SD} = 5\text{ A}$ $di/dt = 100\text{ A}/\mu\text{s}$ $V_{DD} = 10\text{ V}$ $T_j = 150^\circ\text{C}$ (see test circuit, Figure 3)		26 13 1		ns nC A

(\*)Pulsed: Pulse duration = 300  $\mu\text{s}$ , duty cycle 1.5 %.  
( $\bullet$ )Pulse width limited by safe operating area.

**Safe Operating Area**

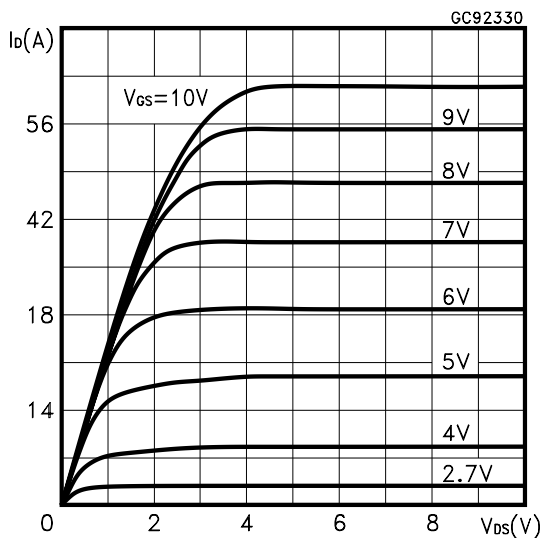


**Thermal Impedance**

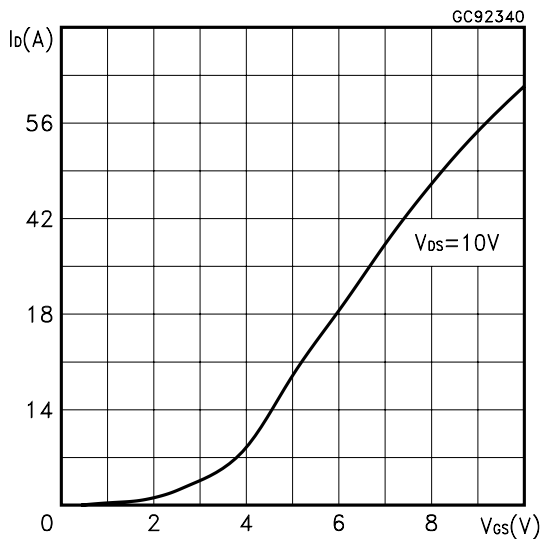


# STC5NF30V

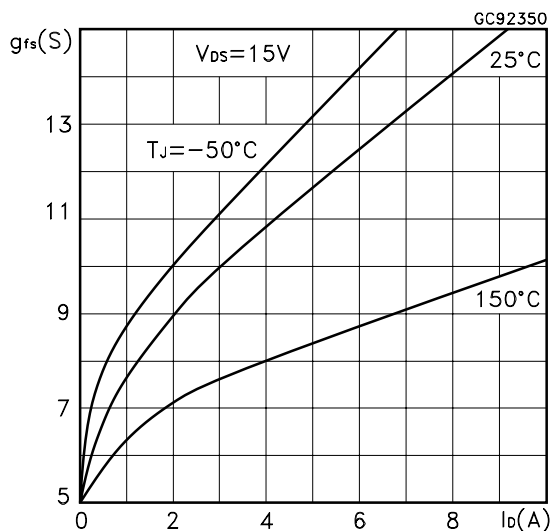
Output Characteristics



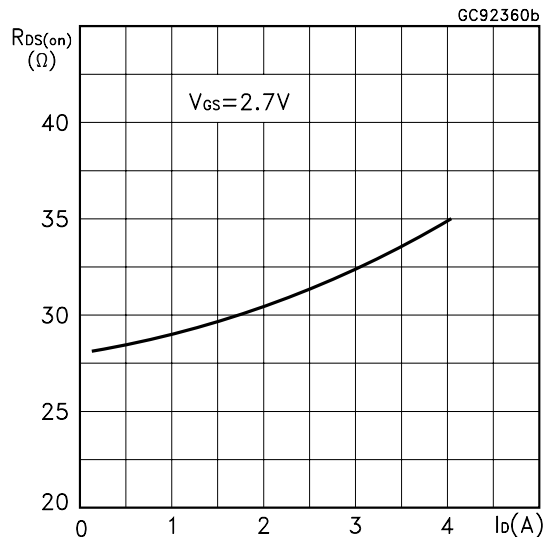
Transfer Characteristics



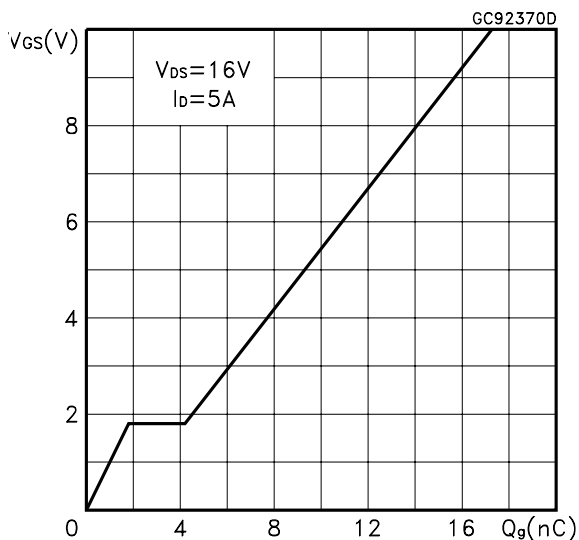
Transconductance



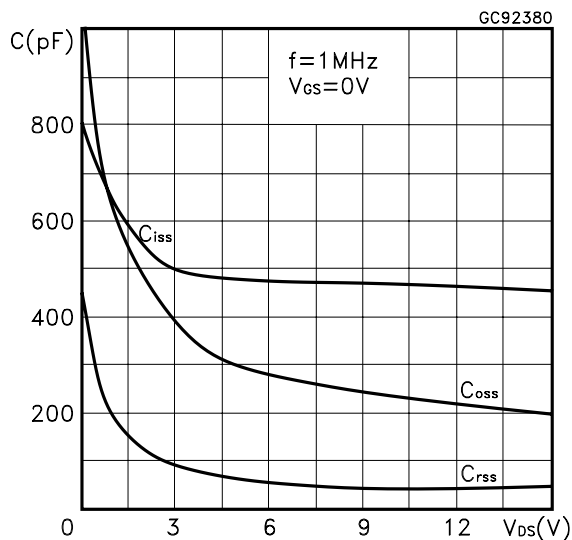
Static Drain-source On Resistance



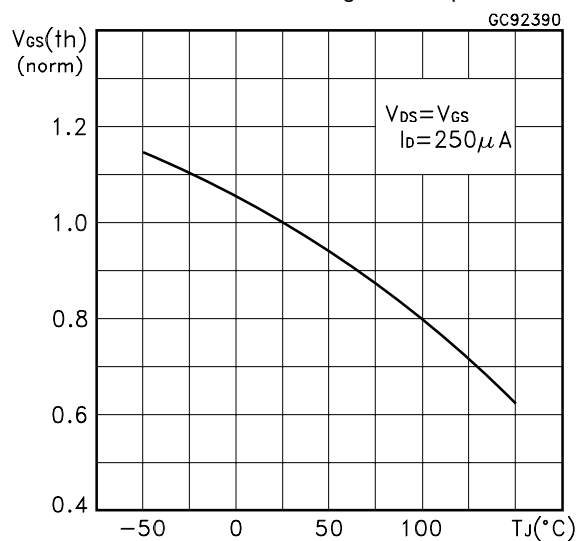
Gate Charge vs Gate-source Voltage



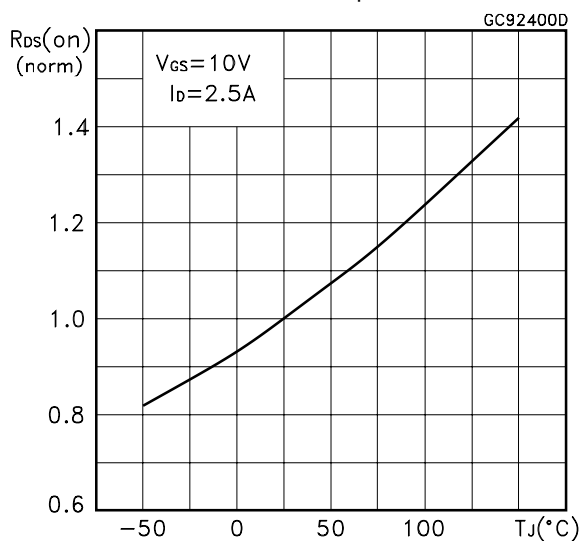
Capacitance Variations



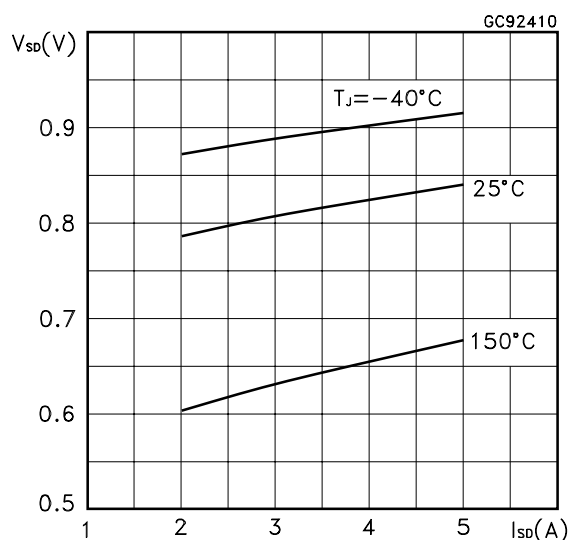
Normalized Gate Threshold Voltage vs Temperature



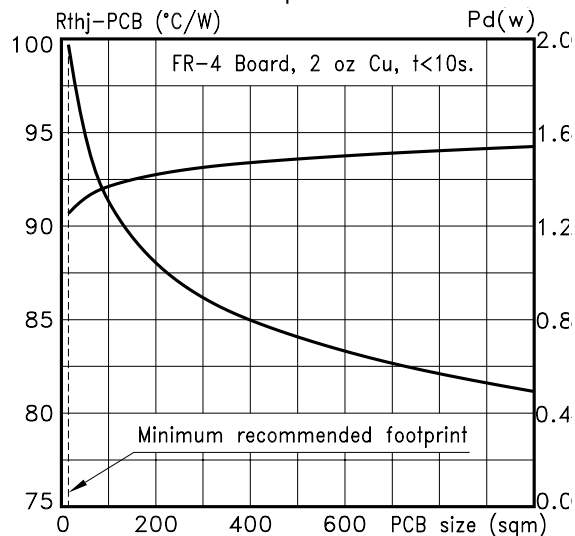
Normalized on Resistance vs Temperature



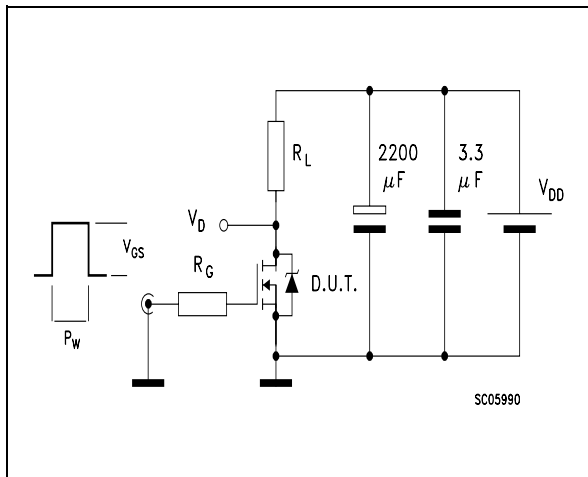
Source-drain Diode Forward Characteristics



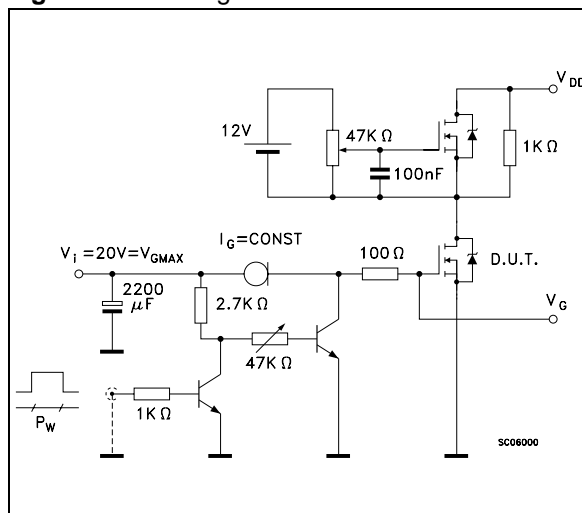
Thermal resistance and max power



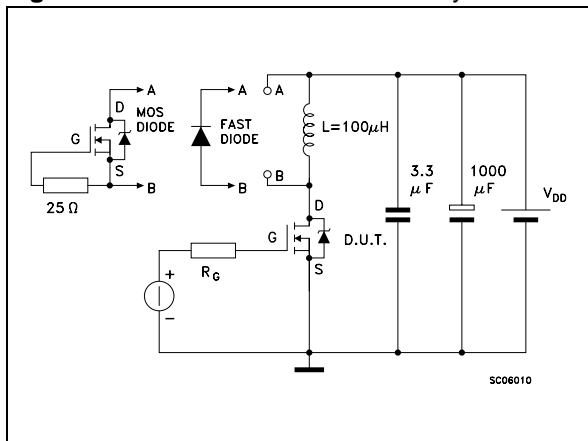
**Fig. 1: Switching Times Test Circuits For Resistive Load**



**Fig. 2: Gate Charge test Circuit**

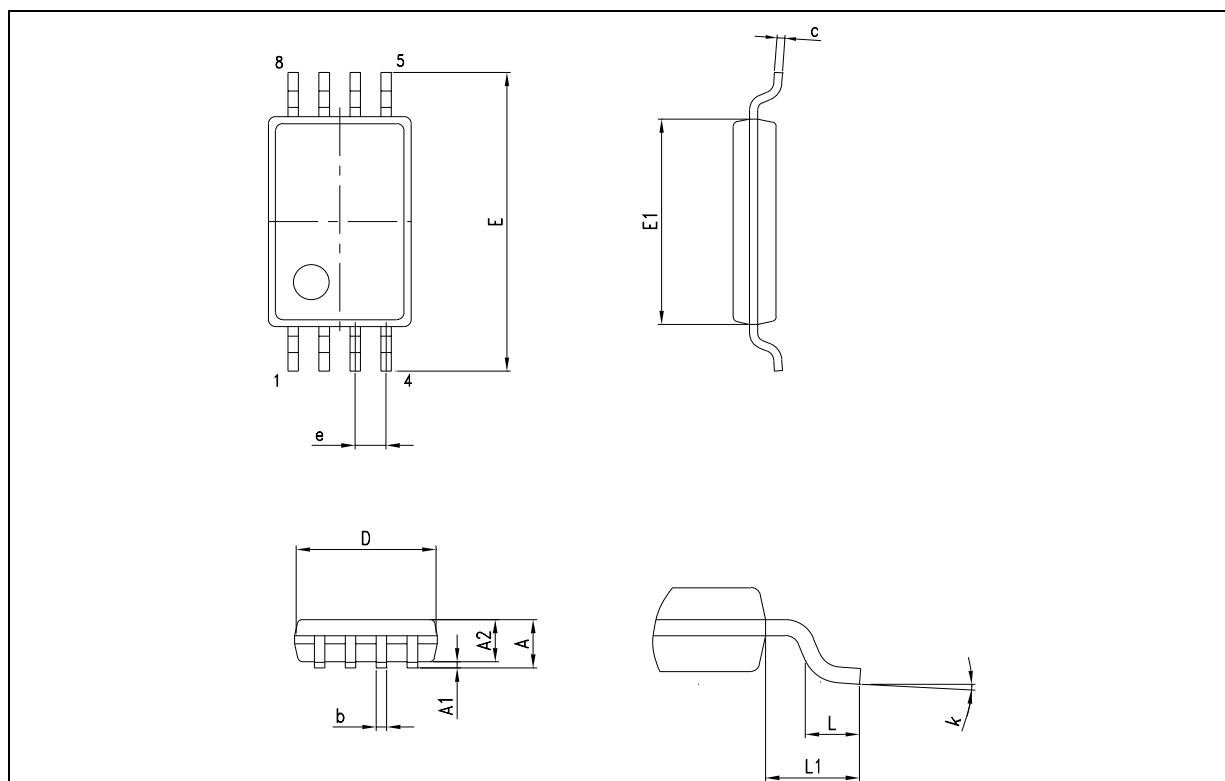


**Fig. 3: Test Circuit For Diode Recovery Behaviour**



## TSSOP8 MECHANICAL DATA

DIM.	mm.			inch.		
	MIN.	TYP.	MAX.	MIN.	TYP.	MAX.
A	1.05		1.20	0.041		0.047
A1	0.05		0.15	0.002		0.006
A2	0.80		1.05	0.032		0.041
b	0.19		0.30	0.008		0.012
c	0.090		0.20	0.003		0.007
D	2.90		3.10	0.114		0.122
E	6.20		6.60	0.240		0.260
E1	4.30		4.50	0.170		0.177
e		0.65			0.025	
L	0.45		0.75	0.018		0.030
L1		1.00			0.039	
k	0°		8°	0.192		0.208



Information furnished is believed to be accurate and reliable. However, STMicroelectronics assumes no responsibility for the consequences of use of such information nor for any infringement of patents or other rights of third parties which may result from its use. No license is granted by implication or otherwise under any patent or patent rights of STMicroelectronics. Specifications mentioned in this publication are subject to change without notice. This publication supersedes and replaces all information previously supplied. STMicroelectronics products are not authorized for use as critical components in life support devices or systems without express written approval of STMicroelectronics.

The ST logo is registered trademark of STMicroelectronics  
© 2003 STMicroelectronics - All Rights Reserved

All other names are the property of their respective owners.

STMicroelectronics GROUP OF COMPANIES  
Australia - Brazil - Canada - China - Finland - France - Germany - Hong Kong - India - Israel - Italy - Japan - Malaysia - Malta - Morocco -  
Singapore - Spain - Sweden - Switzerland - United Kingdom - United States.

<http://www.st.com>