



STD1LNK60Z-1 STQ1NK60ZR - STN1NK60Z

N-CHANNEL 600V 13Ω 0.8A TO-92/IPAK/SOT-223
Zener-Protected SuperMESH™ MOSFET

Table 1: General Features

TYPE	V _{DSS}	R _{DS(on)}	I _D	P _w
STQ1NK60ZR	600 V	< 15 Ω	0.3 A	3 W
STD1LNK60Z-1	600 V	< 15 Ω	0.8 A	25 W
STN1NK60Z	600 V	< 15 Ω	0.3 A	3.3 W

- TYPICAL R_{DS(on)} = 13Ω
- EXTREMELY HIGH dv/dt CAPABILITY
- ESD IMPROVED CAPABILITY
- 100% AVALANCHE TESTED
- NEW HIGH VOLTAGE BENCHMARK
- GATE CHARGE MINIMIZED

DESCRIPTION

The SuperMESH™ series is obtained through an extreme optimization of ST's well established strip-based PowerMESH™ layout. In addition to pushing on-resistance significantly down, special care is taken to ensure a very good dv/dt capability for the most demanding applications. Such series complements ST full range of high voltage MOSFETs including revolutionary MDmesh™ products.

APPLICATIONS

- AC ADAPTORS AND BATTERY CHARGERS
- SWITCH MODE POWER SUPPLIES (SMPS)

Table 2: Order Codes

SALES TYPE	MARKING	PACKAGE	PACKAGING
STQ1NK60ZR	Q1NK60ZR	TO-92	BULK
STQ1NK60ZR-AP	Q1NK60ZR	TO-92	AMMOPAK
STD1LNK60Z-1	D1LNK60Z	IPAK	TUBE
STN1NK60Z	N1NK60Z	SOT-223	TAPE & REEL

Figure 1: Package

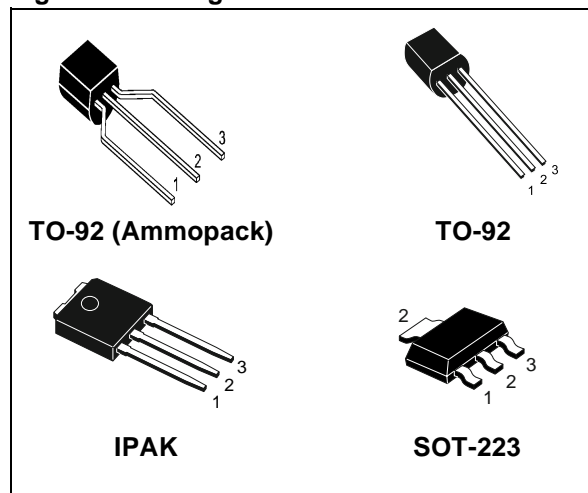

Figure 2: Internal Schematic Diagram

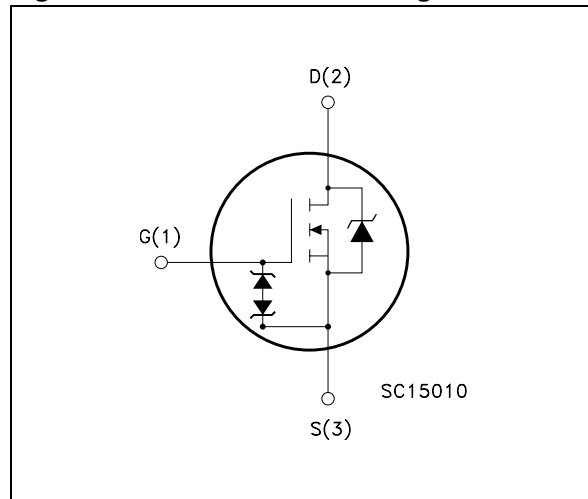

Table 3: Absolute Maximum ratings

Symbol	Parameter	Value			Unit
		IPAK	TO-92	SOT-223	
V _{DS}	Drain-source Voltage (V _{GS} = 0)	600			V
V _{DGR}	Drain-gate Voltage (R _{GS} = 20 kΩ)	600			V
V _{GS}	Gate- source Voltage	± 30			V
I _D	Drain Current (continuous) at T _C = 25°C	0.8	0.3	0.3	A
I _D	Drain Current (continuous) at T _C = 100°C	0.5	0.189	0.189	A
I _{DM} (•)	Drain Current (pulsed)	3.2	1.2	1.2	A
P _{TOT}	Total Dissipation at T _C = 25°C	25	3	3.3	W
	Derating Factor	0.24	0.025	0.026	W/°C
V _{ESD(G-S)}	Gate source ESD(HBM-C=100pF, R=1.5KΩ)	800			V
dv/dt (1)	Peak Diode Recovery voltage slope	4.5			V/ns
T _j T _{stg}	Operating Junction Temperature Storage Temperature	-55 to 150			°C

(•) Pulse width limited by safe operating area

(1) I_{SD} ≤ 0.3A, di/dt ≤ 200A/μs, V_{DD} ≤ V_{(BR)DSS}, T_j ≤ T_{JMAX}.

Table 4: Thermal Data

		IPAK	TO-92	SOT-223	
R _{thj-case}	Thermal Resistance Junction-case Max	5	--	--	°C/W
R _{thj-amb}	Thermal Resistance Junction-ambient Max	100	120	37.87(#)	°C/W
R _{thj-lead}	Thermal Resistance Junction-lead Max	--	40	--	°C/W
T _l	Maximum Lead Temperature For Soldering Purpose	275	260	260	°C

(#) When mounted on 1 inch² Fr-4 board, 2 Oz Cu

Table 5: Avalanche Characteristics

Symbol	Parameter	Max Value	Unit
I _{AR}	Avalanche Current, Repetitive or Not-Repetitive (pulse width limited by T _j max)	0.8	A
E _{AS}	Single Pulse Avalanche Energy (starting T _j = 25 °C, I _D = I _{AR} , V _{DD} = 50 V)	60	mJ

Table 6: Gate-Source Zener Diode

Symbol	Parameter	Test Conditions	Min.	Typ.	Max.	Unit
BV _{GSO}	Gate-Source Breakdown Voltage	I _{gs} = ± 1mA (Open Drain)	30			V

PROTECTION FEATURES OF GATE-TO-SOURCE ZENER DIODES

The built-in back-to-back Zener diodes have specifically been designed to enhance not only the device's ESD capability, but also to make them safely absorb possible voltage transients that may occasionally be applied from gate to source. In this respect the Zener voltage is appropriate to achieve an efficient and cost-effective intervention to protect the device's integrity. These integrated Zener diodes thus avoid the usage of external components.

ELECTRICAL CHARACTERISTICS ($T_{CASE} = 25^{\circ}C$ UNLESS OTHERWISE SPECIFIED)

Table 7: On /Off

Symbol	Parameter	Test Conditions	Min.	Typ.	Max.	Unit
$V_{(BR)DSS}$	Drain-source Breakdown Voltage	$I_D = 1\text{ mA}, V_{GS} = 0$	600			V
I_{DSS}	Zero Gate Voltage Drain Current ($V_{GS} = 0$)	$V_{DS} = \text{Max Rating}$ $V_{DS} = \text{Max Rating},$ $T_C = 125^{\circ}C$			1 50	μA μA
I_{GSS}	Gate-body Leakage Current ($V_{DS} = 0$)	$V_{GS} = \pm 20V$			± 10	μA
$V_{GS(th)}$	Gate Threshold Voltage	$V_{DS} = V_{GS}, I_D = 50\ \mu A$	3	3.75	4.5	V
$R_{DS(on)}$	Static Drain-source On Resistance	$V_{GS} = 10V, I_D = 0.4\text{ A}$		13	15	Ω

Table 8: Dynamic

Symbol	Parameter	Test Conditions	Min.	Typ.	Max.	Unit
g_{fs} (1)	Forward Transconductance	$V_{DS} = V, I_D = 0.4\text{ A}$		0.5		S
C_{iss} C_{oss} C_{rss}	Input Capacitance Output Capacitance Reverse Transfer Capacitance	$V_{DS} = 25V, f = 1\text{ MHz}, V_{GS} = 0$		94 17.6 2.8		pF pF pF
$C_{oss\ eq.}$ (3)	Equivalent Output Capacitance	$V_{GS} = 0V, V_{DS} = 0V\text{ to }480V$		11		pF
$t_{d(on)}$ t_r $t_{d(off)}$ t_f	Turn-on Delay Time Rise Time Turn-off-Delay Time Fall Time	$V_{DD} = 300V, I_D = 0.4\text{ A}$ $R_G = 4.7\Omega, V_{GS} = 10\text{ V}$ (see Figure 21)		5.5 5 13 28		ns ns ns ns
Q_g Q_{gs} Q_{gd}	Total Gate Charge Gate-Source Charge Gate-Drain Charge	$V_{DD} = 480V, I_D = 0.8\text{ A},$ $V_{GS} = 10V$ (see Figure 25)		4.9 1 2.7	6.9	nC nC nC

Table 9: Source Drain Diode

Symbol	Parameter	Test Conditions	Min.	Typ.	Max.	Unit
I_{SD} I_{SDM} (2)	Source-drain Current Source-drain Current (pulsed)				0.8 2.4	A A
V_{SD} (1)	Forward On Voltage	$I_{SD} = 0.8A, V_{GS} = 0$			1.6	V
t_{rr} Q_{rr} I_{RRM}	Reverse Recovery Time Reverse Recovery Charge Reverse Recovery Current	$I_{SD} = 0.8\text{ A}, di/dt = 100A/\mu s$ $V_{DD} = 20V, T_j = 25^{\circ}C$ (see Figure 23)		135 216 3.2		ns nC A
t_{rr} Q_{rr} I_{RRM}	Reverse Recovery Time Reverse Recovery Charge Reverse Recovery Current	$I_{SD} = 0.8\text{ A}, di/dt = 100A/\mu s$ $V_{DD} = 20V, T_j = 150^{\circ}C$ (see Figure 23)		140 224 3.2		ns nC A

Note: 1. Pulsed: Pulse duration = 300 μs , duty cycle 1.5 %.
 2. Pulse width limited by safe operating area.
 3. $C_{oss\ eq.}$ is defined as a constant equivalent capacitance giving the same charging time as C_{oss} when V_{DS} increases from 0 to 80% V_{DSS} .

Figure 3: Safe Operating Area for IPAK

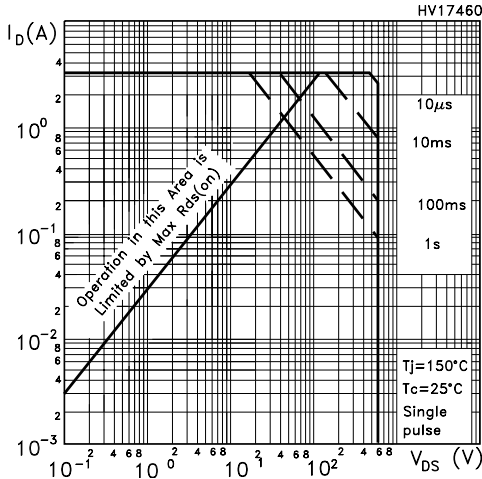

Figure 4: Safe Operating Area for TO-92

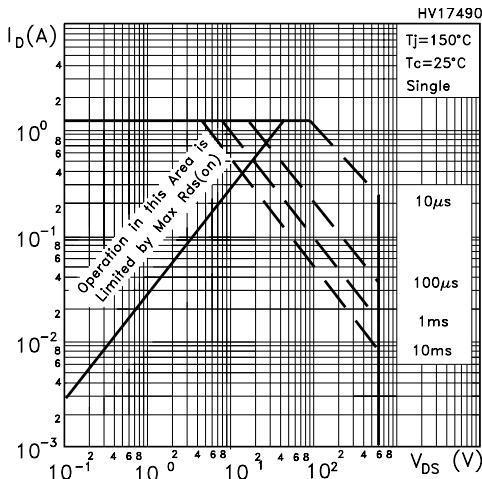

Figure 5: Safe Operating Area for SOT-223

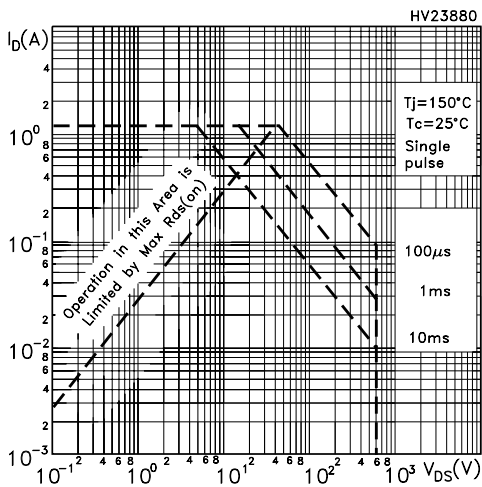

Figure 6: Thermal Impedance for IPAK

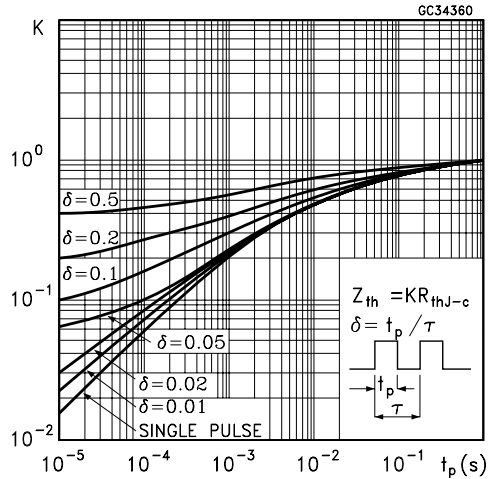

Figure 7: Thermal Impedance for TO-92

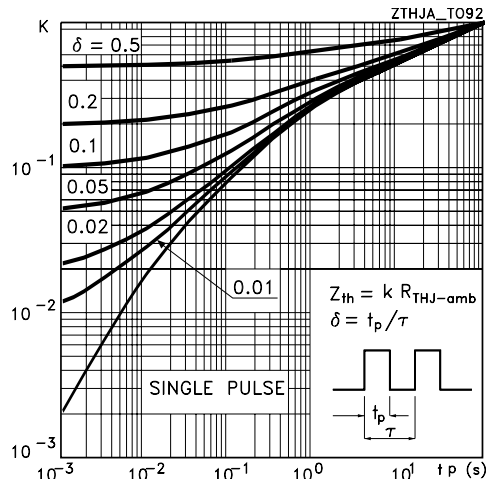

Figure 8: Thermal Impedance for SOT-223

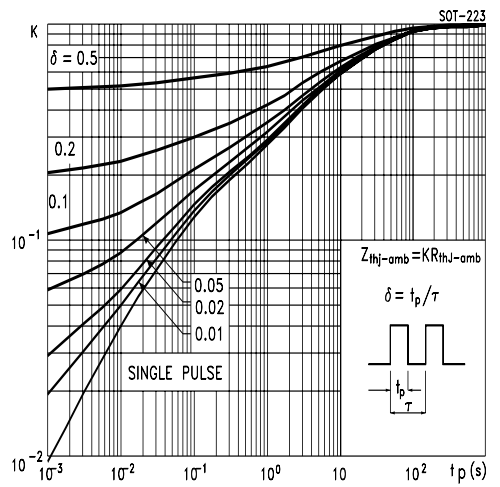

Figure 9: Output Characteristics

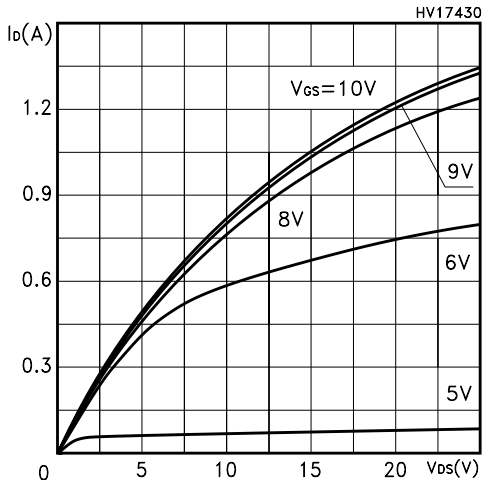

Figure 10: Transconductance

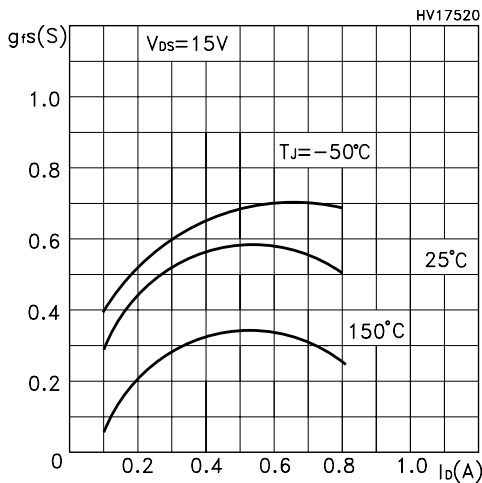

Figure 11: Gate Charge vs Gate-source Voltage

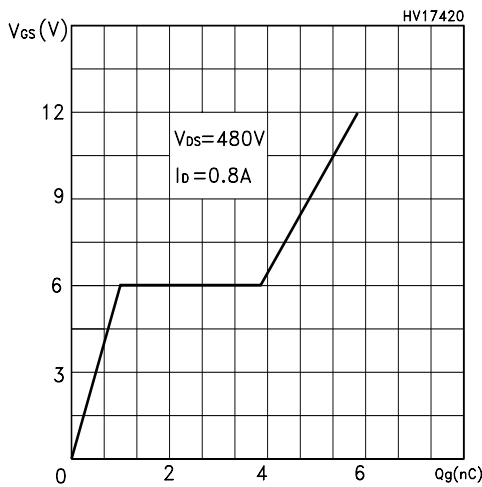

Figure 12: Transfer Characteristics

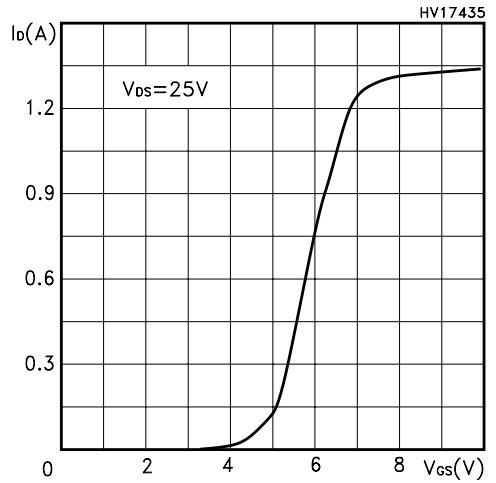

Figure 13: Static Drain-Source On Resistance

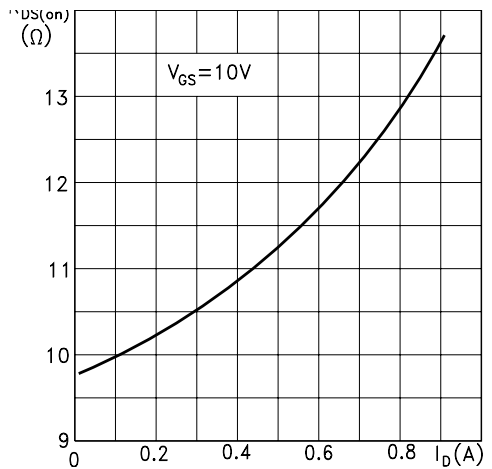

Figure 14: Capacitance Variation

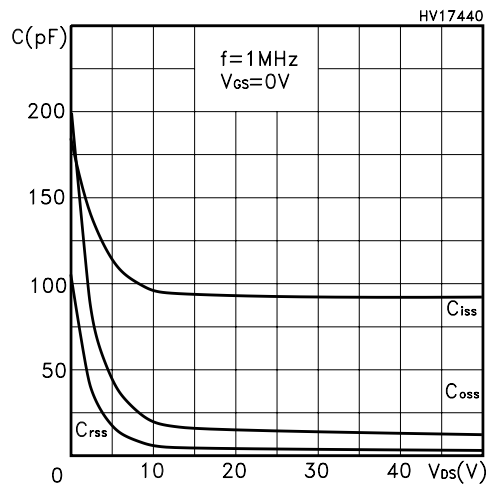

Figure 15: Normalized Gate Threshold Voltage vs Temperature

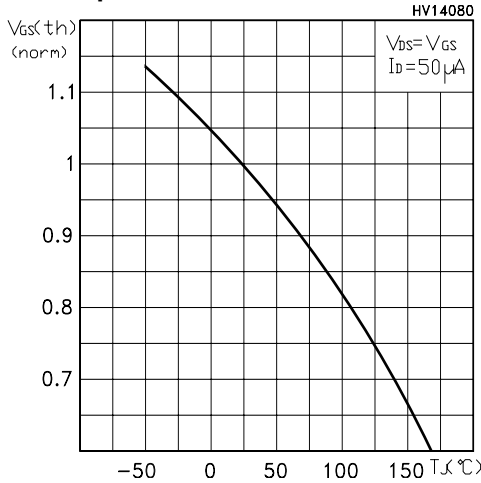

Figure 16: Source-Drain Diode Forward Characteristics

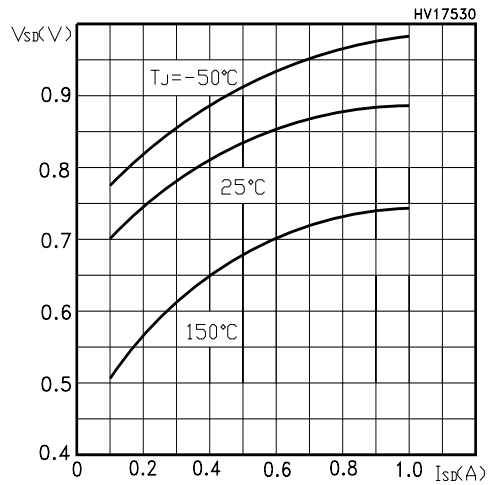

Figure 17: Maximum Avalanche Energy vs Temperature

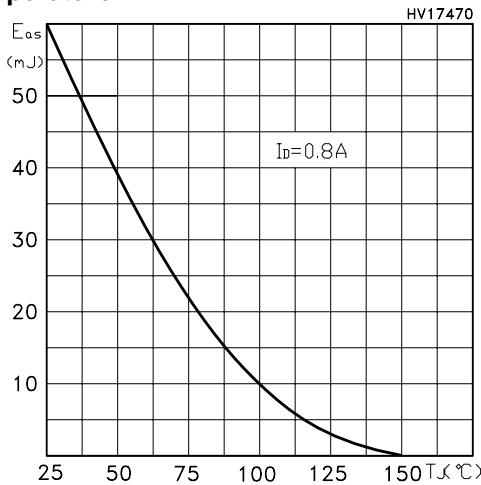

Figure 18: Normalized On Resistance vs Temperature

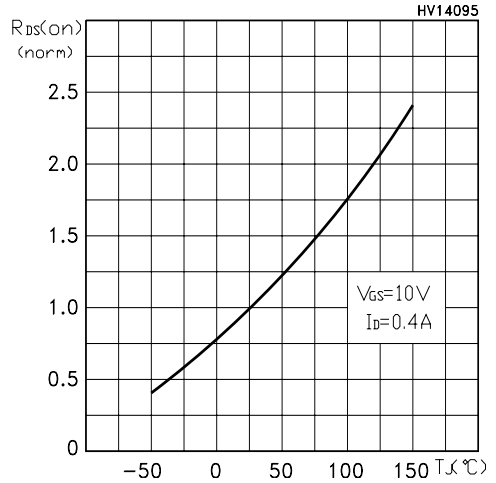

Figure 19: Normalized BVdss vs Temperature

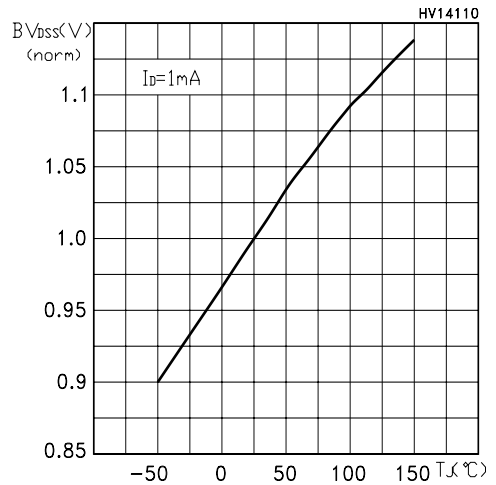

Figure 20: Max Id Current vs Tc

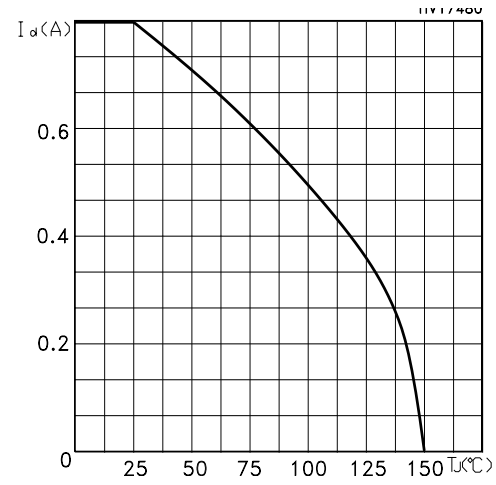

Figure 21: Unclamped Inductive Load Test Circuit

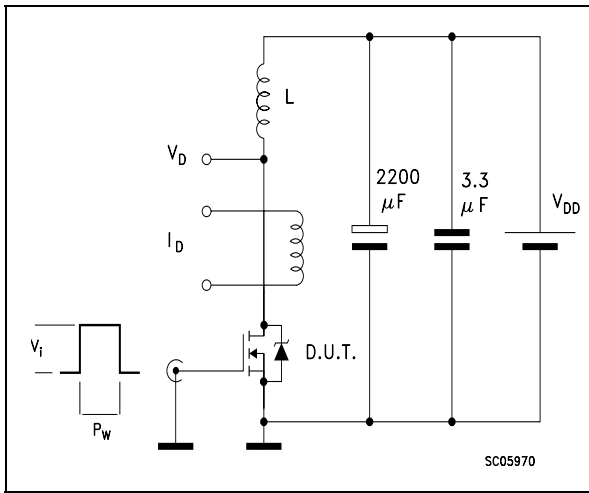

Figure 22: Switching Times Test Circuit For Resistive Load

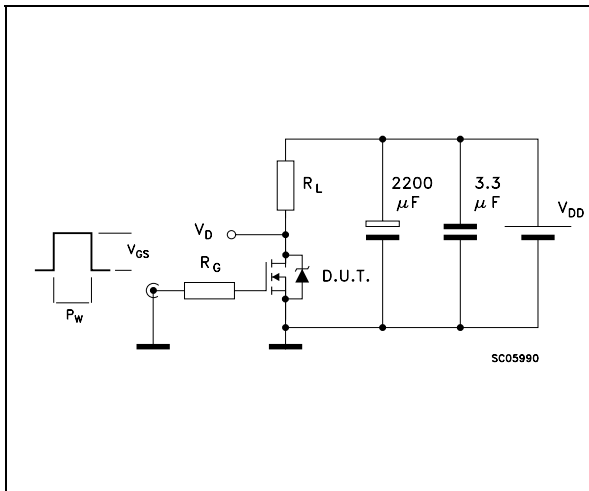

Figure 23: Test Circuit For Inductive Load Switching and Diode Recovery Times

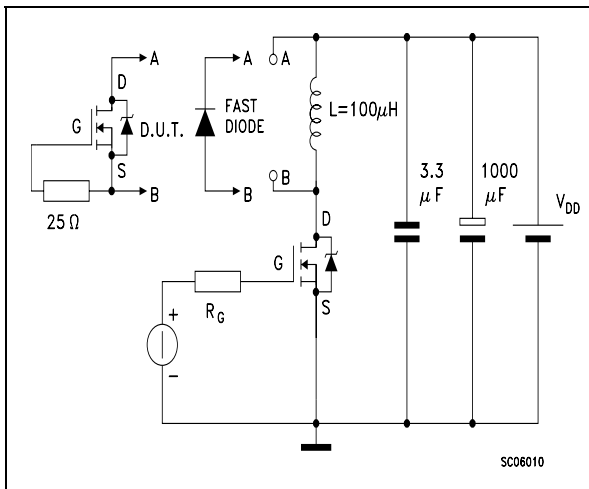

Figure 24: Unclamped Inductive Waferform

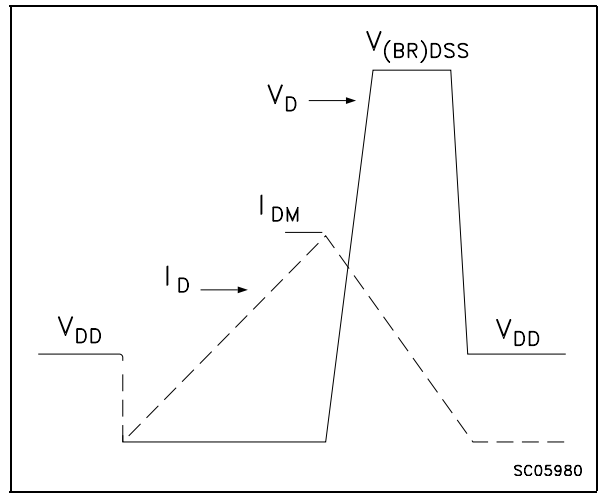
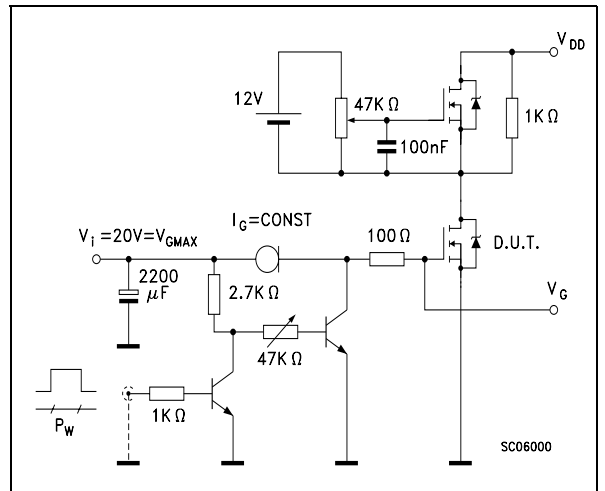
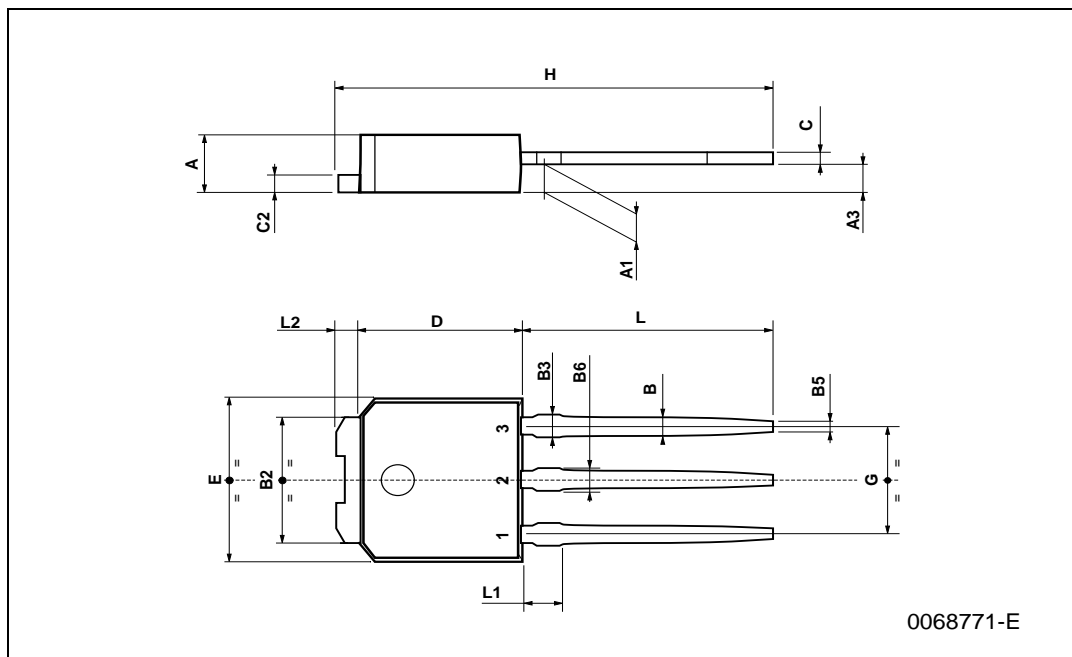

Figure 25: Gate Charge Test Circuit



TO-251 (IPAK) MECHANICAL DATA

DIM.	mm			inch		
	MIN.	TYP.	MAX.	MIN.	TYP.	MAX.
A	2.2		2.4	0.086		0.094
A1	0.9		1.1	0.035		0.043
A3	0.7		1.3	0.027		0.051
B	0.64		0.9	0.025		0.031
B2	5.2		5.4	0.204		0.212
B3			0.85			0.033
B5		0.3			0.012	
B6			0.95			0.037
C	0.45		0.6	0.017		0.023
C2	0.48		0.6	0.019		0.023
D	6		6.2	0.236		0.244
E	6.4		6.6	0.252		0.260
G	4.4		4.6	0.173		0.181
H	15.9		16.3	0.626		0.641
L	9		9.4	0.354		0.370
L1	0.8		1.2	0.031		0.047
L2		0.8	1		0.031	0.039



TO-92 MECHANICAL DATA

DIM.	mm.			inch		
	MIN.	TYP	MAX.	MIN.	TYP.	MAX.
A	4.32		4.95	0.170		0.194
b	0.36		0.51	0.014		0.020
D	4.45		4.95	0.175		0.194
E	3.30		3.94	0.130		0.155
e	2.41		2.67	0.094		0.105
e1	1.14		1.40	0.044		0.055
L	12.70		15.49	0.50		0.610
R	2.16		2.41	0.085		0.094
S1	0.92		1.52	0.036		0.060
W	0.41		0.56	0.016		0.022
V		5°			5°	

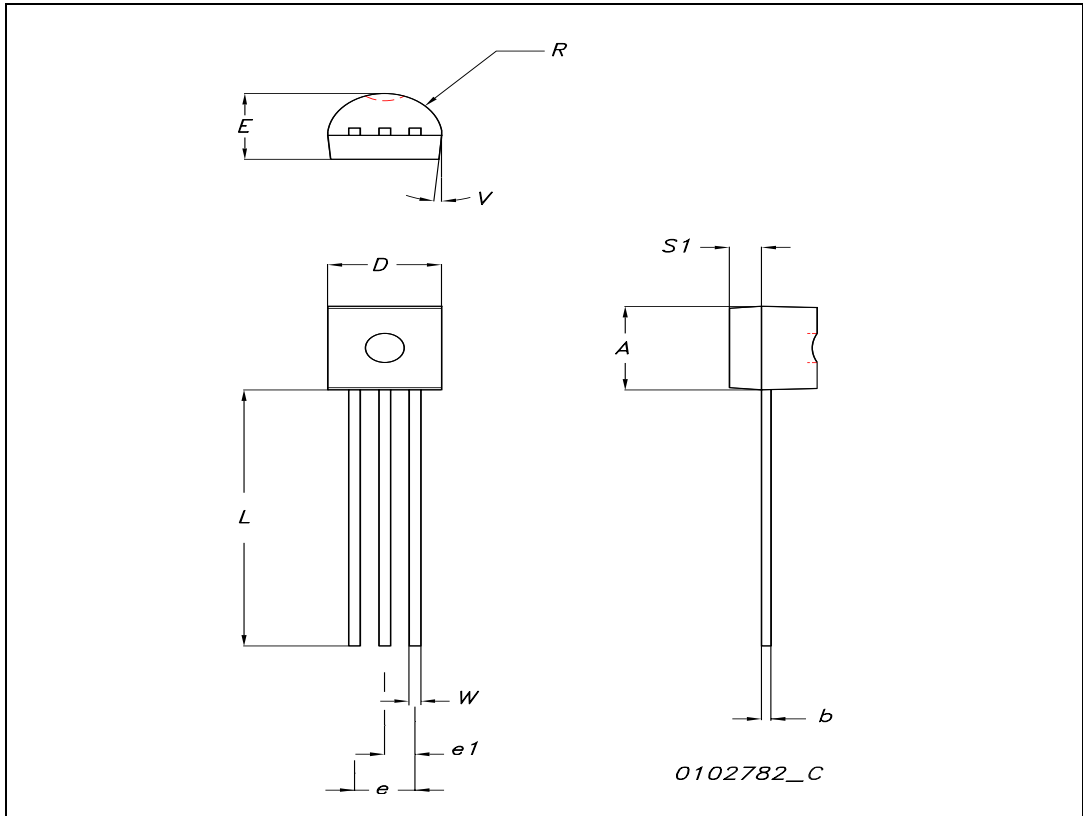

TO-92 AMMOPACK

DIM.	mm.			inch		
	MIN.	TYP.	MAX.	MIN.	TYP.	MAX.
A1	4.45		4.95	0.170		0.194
T	3.30		3.94	0.130		0.155
T1			1.6			0.06
T2			2.3			0.09
d	0.41		0.56	0.016		0.022
P0	12.5	12.7	12.9	0.49	0.5	0.51
P2	5.65	6.35	7.05	0.22	0.25	0.27
F1, F2	2.44	2.54	2.94	0.09	0.1	0.11
delta H	-2		2	-0.08		0.08
W	17.5	18	19	0.69	0.71	0.74
W0	5.7	6	6.3	0.22	0.23	0.24
W1	8.5	9	9.25	0.33	0.35	0.36
W2			0.5			0.02
H	18.5		20.5	0.72		0.80
H0	15.5	16	16.5	0.61	0.63	0.65
H1			25			0.98
D0	3.8	4	4.2	0.15	0.157	0.16
t			0.9			0.035
L			11			0.43
I1	3			0.11		
delta P	-1		1	-0.04		0.04

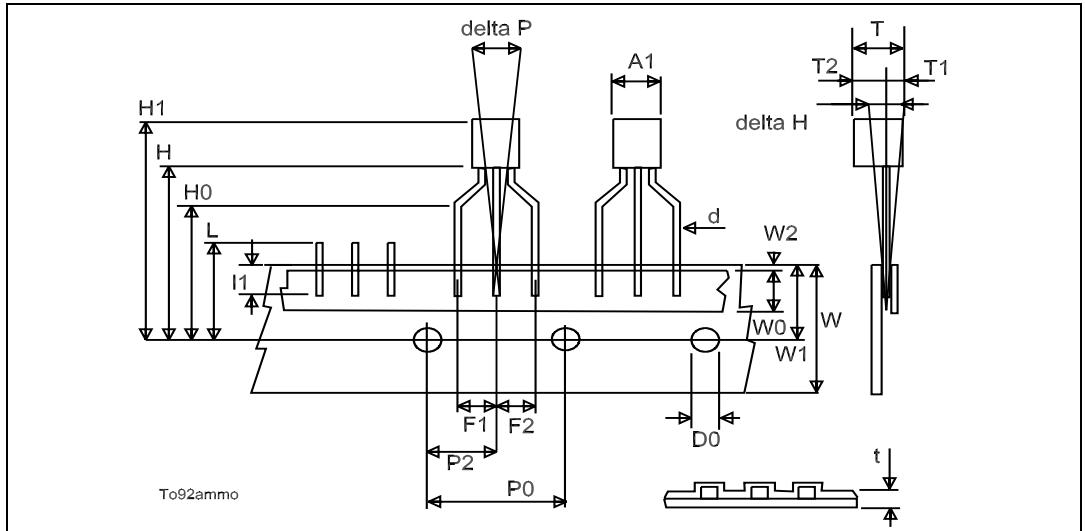

SOT-223 MECHANICAL DATA

DIM.	mm			inch		
	MIN.	TYP.	MAX.	MIN.	TYP.	MAX.
A			1.80			0.071
B	0.60	0.70	0.80	0.024	0.027	0.031
B1	2.90	3.00	3.10	0.114	0.118	0.122
c	0.24	0.26	0.32	0.009	0.010	0.013
D	6.30	6.50	6.70	0.248	0.256	0.264
e		2.30			0.090	
e1		4.60			0.181	
E	3.30	3.50	3.70	0.130	0.138	0.146
H	6.70	7.00	7.30	0.264	0.276	0.287
V			10°			10°
A1		0.02				

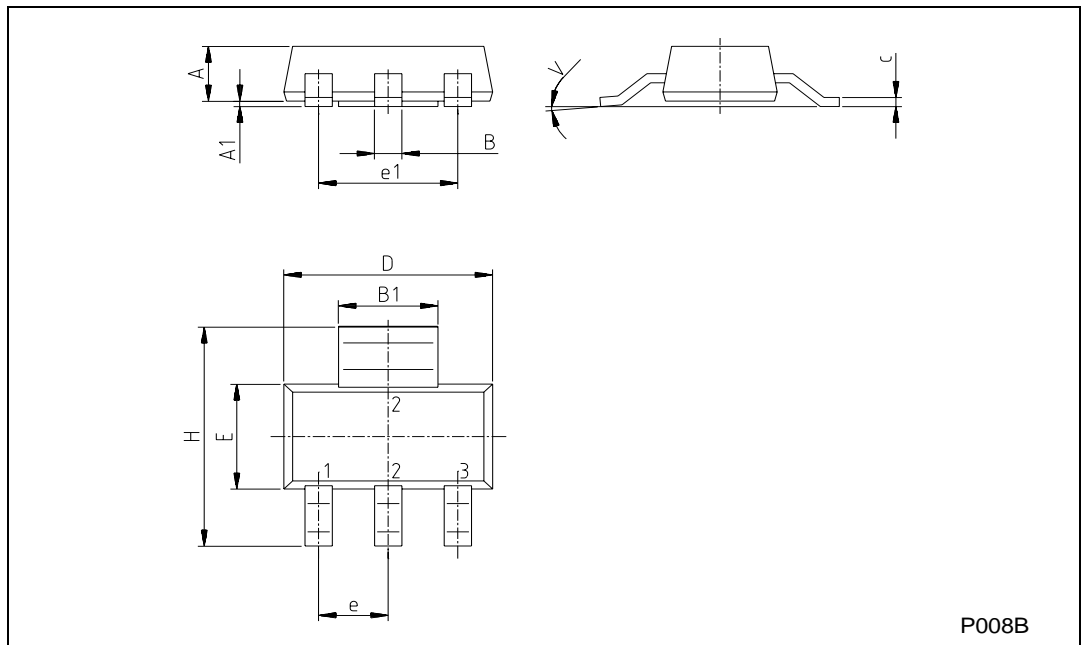

Table 10: Revision History

Date	Revision	Description of Changes
19-Mar-2003	1	First Release
15-May-2003	2	Removed DPAK
09-Jun-2003	3	Final Datasheet
17-Nov-2004	4	Inserted SOT-223.
15-Feb-2005	5	Modified Curve 4

Information furnished is believed to be accurate and reliable. However, STMicroelectronics assumes no responsibility for the consequences of use of such information nor for any infringement of patents or other rights of third parties which may result from its use. No license is granted by implication or otherwise under any patent or patent rights of STMicroelectronics. Specifications mentioned in this publication are subject to change without notice. This publication supersedes and replaces all information previously supplied. STMicroelectronics products are not authorized for use as critical components in life support devices or systems without express written approval of STMicroelectronics.

The ST logo is a registered trademark of STMicroelectronics

All other names are the property of their respective owners

© 2005 STMicroelectronics - All Rights Reserved

STMicroelectronics group of companies

Australia - Belgium - Brazil - Canada - China - Czech Republic - Finland - France - Germany - Hong Kong - India - Israel - Italy - Japan - Malaysia - Malta - Morocco - Singapore - Spain - Sweden - Switzerland - United Kingdom - United States of America