



STGP12NB60H

N-CHANNEL 12A - 600V – TO-220

PowerMESH™ IGBT

TYPE	V _{CES}	V _{CE(sat)}	I _C
STGP12NB60H	600 V	< 2.8 V	12 A

- HIGH INPUT IMPEDANCE
- LOW ON-VOLTAGE DROP (V_{cesat})
- OFF LOSSES INCLUDE TAIL CURRENT
- LOW GATE CHARGE
- HIGH CURRENT CAPABILITY
- VERY HIGH FREQUENCY OPERATION
- CO-PACKAGED WITH TURBOSWITCHT
- TYPICAL SHORT CIRCUIT WITHSTAND TIME
5MICROS S-family, 4 micro H family
- ANTIPARALLEL DIODE

DESCRIPTION

Using the latest high voltage technology based on a patented strip layout, STMicroelectronics has designed an advanced family of IGBTs, the PowerMESH™ IGBTs, with outstanding performances.

The suffix "H" identifies a family optimized for high frequency applications (up to 50kHz) in order to achieve very high switching performances (reduced t_{fall}) maintaining a low voltage drop.

APPLICATIONS

- HIGH FREQUENCY MOTOR CONTROLS
- SMPS and PFC IN BOTH HARD SWITCH AND RESONANT TOPOLOGIES
- UPS

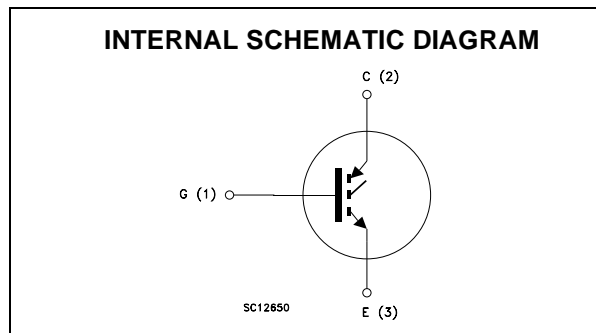
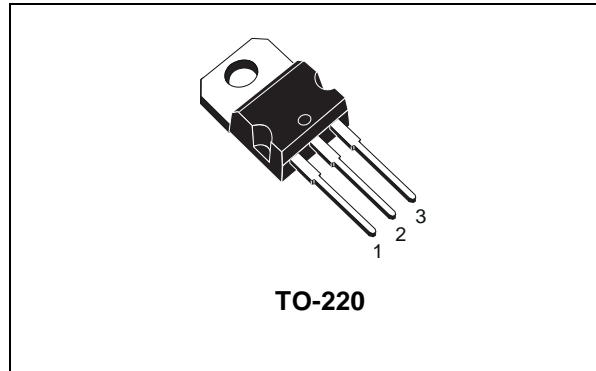

ABSOLUTE MAXIMUM RATINGS

Symbol	Parameter	Value	Unit
V _{CES}	Collector-Emitter Voltage (V _{GS} = 0)	600	V
V _{ECR}	Emitter-Collector Voltage	20	V
V _{GE}	Gate-Emitter Voltage	± 20	V
I _C	Collector Current (continuous) at T _C = 25°C	24	A
I _C	Collector Current (continuous) at T _C = 100°C	12	A
I _{CM} (■)	Collector Current (pulsed)	96	A
P _{TOT}	Total Dissipation at T _C = 25°C	100	W
	Derating Factor	0.8	W/°C
T _{stg}	Storage Temperature	-65 to 150	°C
T _j	Max. Operating Junction Temperature	150	°C

STGP12NB60H

THERMAL DATA

Rthj-case	Thermal Resistance Junction-case Max	1.25	°C/W
Rthj-amb	Thermal Resistance Junction-ambient Max	62.5	°C/W
Rthc-sink	Thermal Resistance Case-sink Typ	0.5	°C/W

ELECTRICAL CHARACTERISTICS (TCASE = 25 °C UNLESS OTHERWISE SPECIFIED)

OFF

Symbol	Parameter	Test Conditions	Min.	Typ.	Max.	Unit
$V_{BR(CEs)}$	Collectro-Emitter Breakdown Voltage	$I_C = 250 \mu A, V_{GE} = 0$	600			V
I_{CES}	Collector cut-off ($V_{GE} = 0$)	$V_{CE} = \text{Max Rating}, T_C = 25 \text{ }^\circ\text{C}$ $V_{CE} = \text{Max Rating}, T_C = 125 \text{ }^\circ\text{C}$			10 100	μA μA
I_{GES}	Gate-Emitter Leakage Current ($V_{CE} = 0$)	$V_{GE} = \pm 20V, V_{CE} = 0$			± 100	nA

ON (1)

Symbol	Parameter	Test Conditions	Min.	Typ.	Max.	Unit
$V_{GE(th)}$	Gate Threshold Voltage	$V_{CE} = V_{GE}, I_C = 250 \mu A$	3		5	V
$V_{CE(sat)}$	Collector-Emitter Saturation Voltage	$V_{GE} = 15V, I_C = 12 A$ $V_{GE} = 15V, I_C = 12 A, T_J = 125^\circ\text{C}$		2.0 1.7	2.8	V V

DYNAMIC

Symbol	Parameter	Test Conditions	Min.	Typ.	Max.	Unit
g_{fs}	Forward Transconductance	$V_{CE} = 25 V, I_C = 12 A$		9.5		S
C_{ies}	Input Capacitance	$V_{CE} = 25V, f = 1 \text{ MHz}, V_{GE} = 0$		950		pF
C_{oes}	Output Capacitance			120		pF
C_{res}	Reverse Transfer Capacitance			27		pF
Q_g Q_{ge} Q_{gc}	Total Gate Charge Gate-Emitter Charge Gate-Collector Charge	$V_{CE} = 480V, I_C = 12 A,$ $V_{GE} = 15V$		68 10 30		nC nC nC
I_{CL}	Latching Current	$V_{clamp} = 480 V, T_J = 150^\circ\text{C}$ $R_G = 10 \Omega$	48			A

SWITCHING ON

Symbol	Parameter	Test Conditions	Min.	Typ.	Max.	Unit
$t_{d(on)}$ t_r	Turn-on Delay Time Rise Time	$V_{CC} = 480 V, I_C = 12 A$ $R_G = 10\Omega, V_{GE} = 15 V$		5 46		ns ns
$(di/dt)_{on}$ E_{on}	Turn-on Current Slope Turn-on Switching Losses	$V_{CC} = 480 V, I_C = 12 A$ $R_G = 10\Omega, V_{GE} = 15 V,$ $T_J = 125^\circ\text{C}$		1000 290		A/ μs μJ

ELECTRICAL CHARACTERISTICS (CONTINUED)

SWITCHING OFF

Symbol	Parameter	Test Conditions	Min.	Typ.	Max.	Unit
t_c	Cross-over Time	$V_{CC} = 480\text{ V}, I_C = 12\text{ A},$ $R_{GE} = 10\ \Omega, V_{GE} = 15\text{ V}$		150		ns
$t_r(V_{off})$	Off Voltage Rise Time			27		ns
$t_{d(off)}$	Delay Time			76		ns
t_f	Fall Time			92		ns
$E_{off(**)}$	Turn-off Switching Loss			0.21		mJ
E_{ts}	Total Switching Loss			0.49		mJ
t_c	Cross-over Time	$V_{CC} = 480\text{ V}, I_C = 12\text{ A},$ $R_{GE} = 10\ \Omega, V_{GE} = 15\text{ V}$ $T_j = 125\text{ }^\circ\text{C}$		230		ns
$t_r(V_{off})$	Off Voltage Rise Time			76		ns
$t_{d(off)}$	Delay Time			95		ns
t_f	Fall Time			200		ns
$E_{off(**)}$	Turn-off Switching Loss			0.45		mJ
E_{ts}	Total Switching Loss			0.74		mJ

Note: 1. Pulsed: Pulse duration = 300 μs , duty cycle 1.5 %.
 2. Pulse width limited by max. junction temperature.
 (**))Losses include Also the Tail (Jedec Standardization)

Thermal Impedance

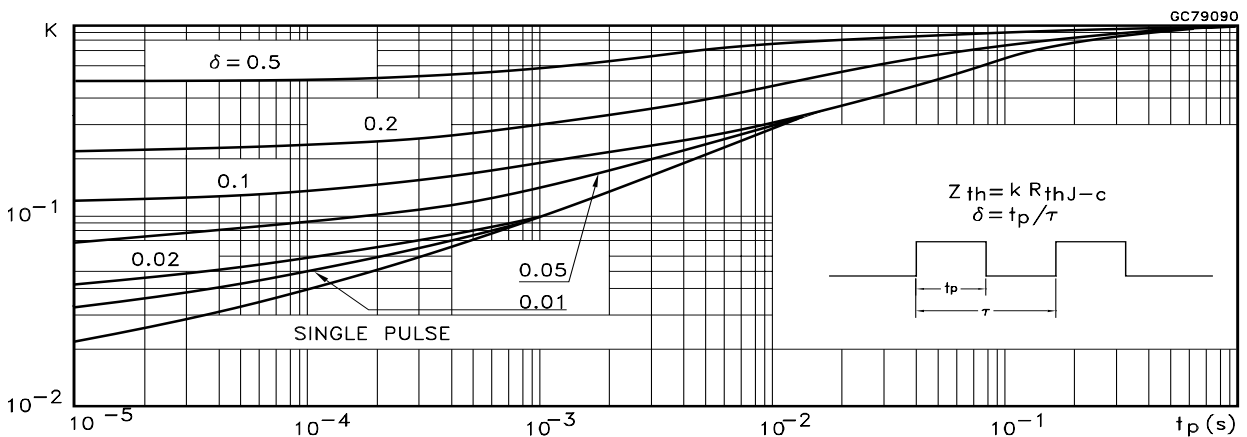

Output Characteristics

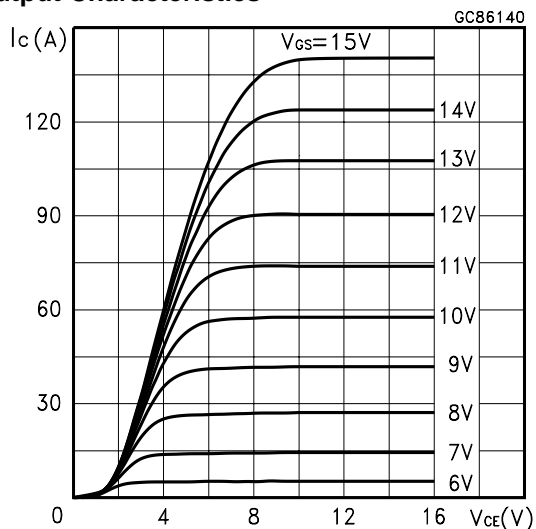

Transfer Characteristics

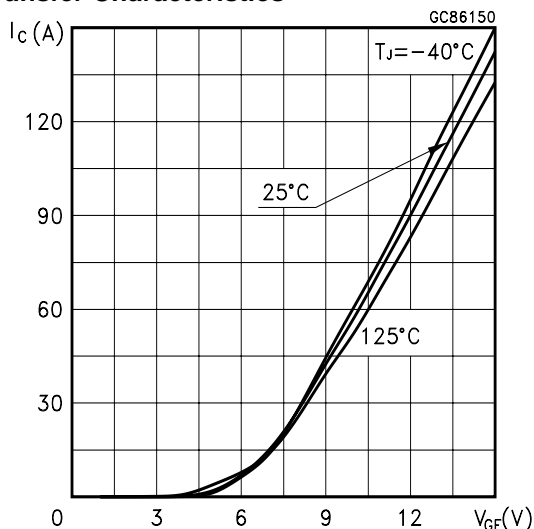

Transconductance

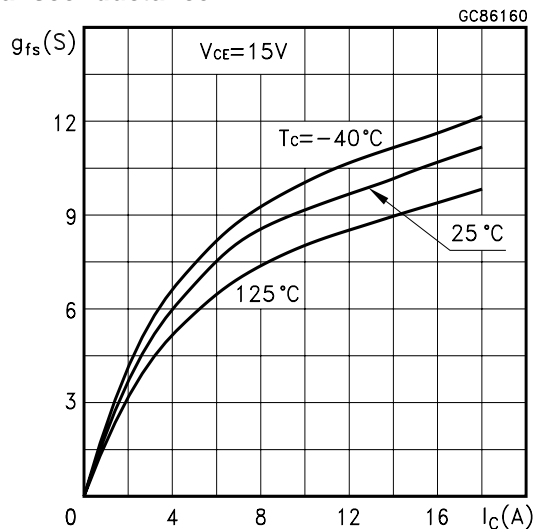

Collector-Emitter On Voltage vs Temperature

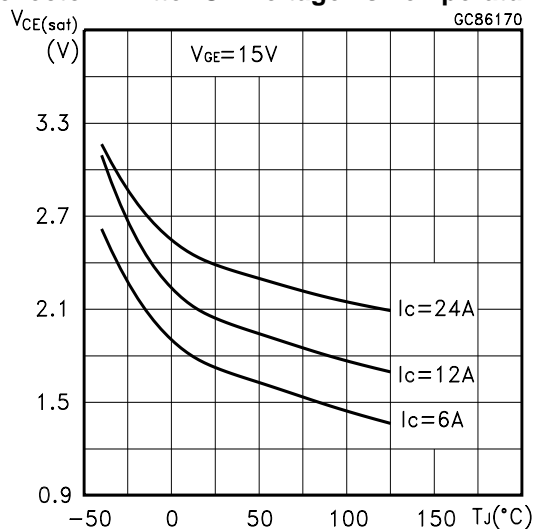

Collector-Emitter On Voltage vs Collector Current

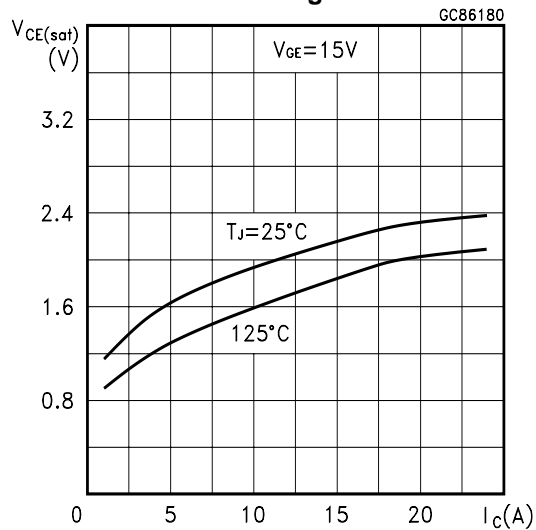

Gate Threshold vs Temperature

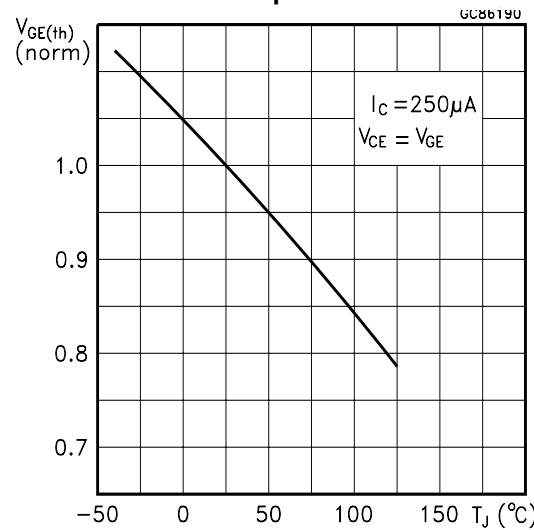

Normalized Breakdown Voltage vs Temperature

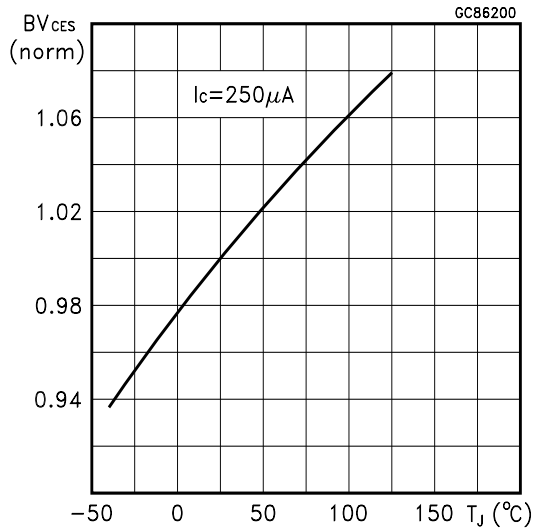

Capacitance Variations

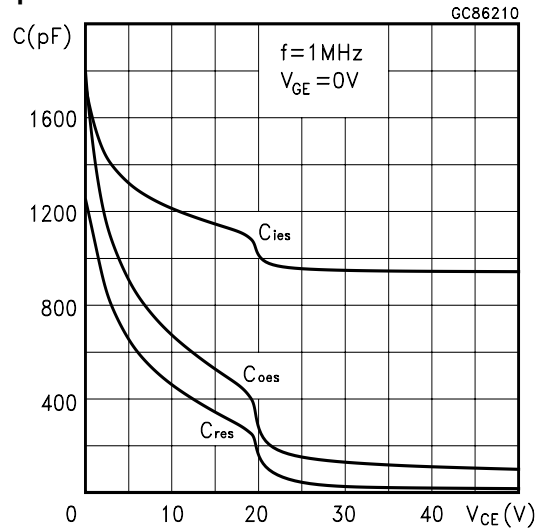

Gate Charge vs Gate-Emitter Voltage

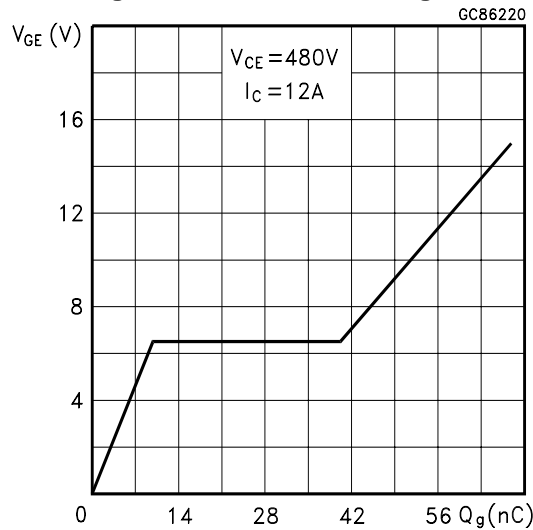

Total Switching Losses vs Gate Resistance

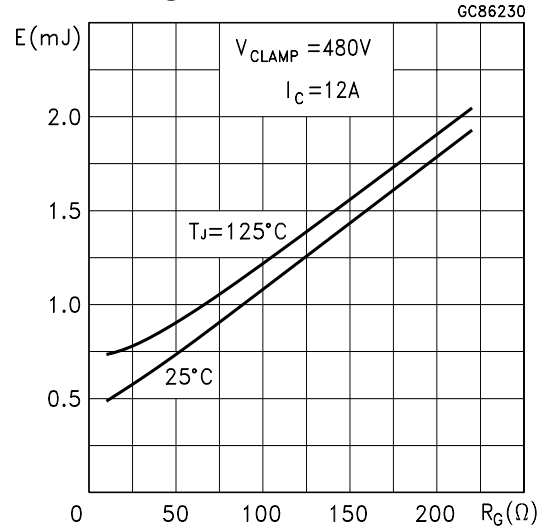

Total Switching Losses vs Temperature

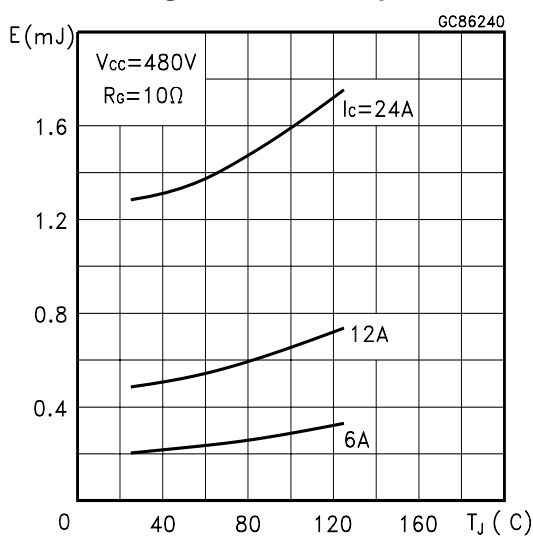

Total Switching Losses vs Collector Current

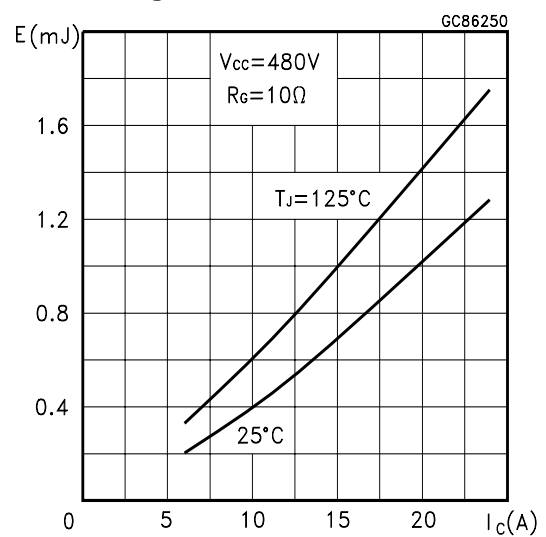

Switching Off Safe Operating Area

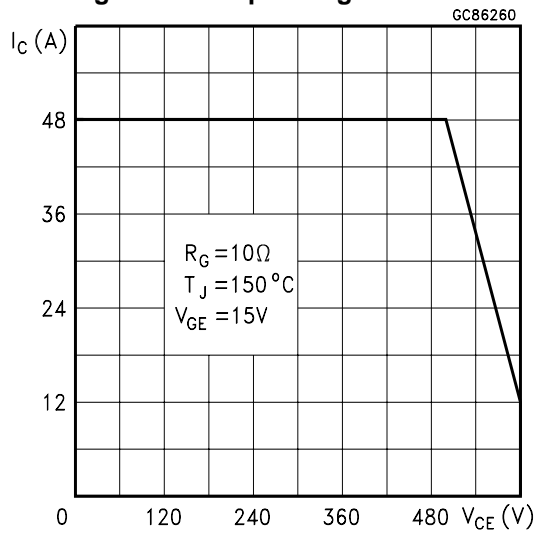

Fig. 1: Gate Charge test Circuit

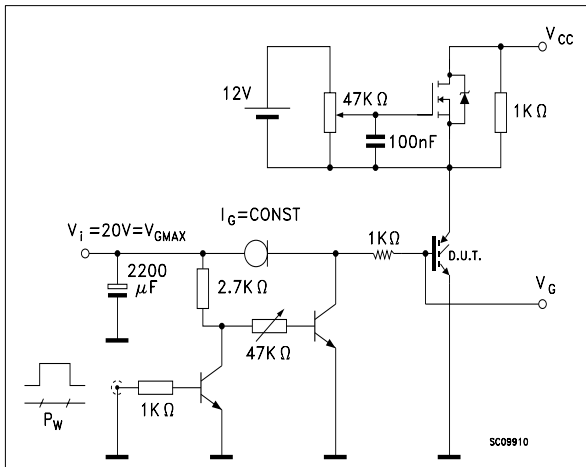
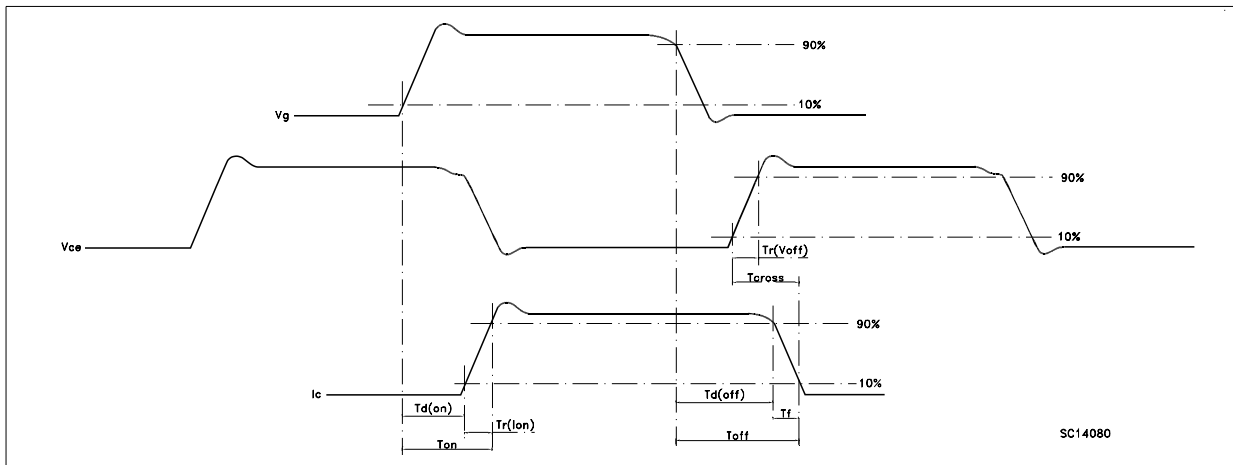
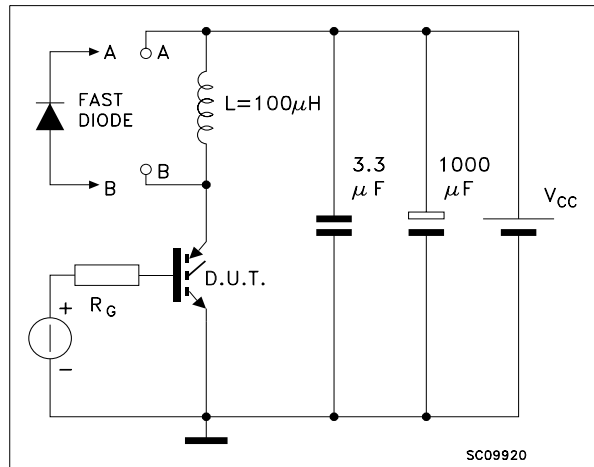
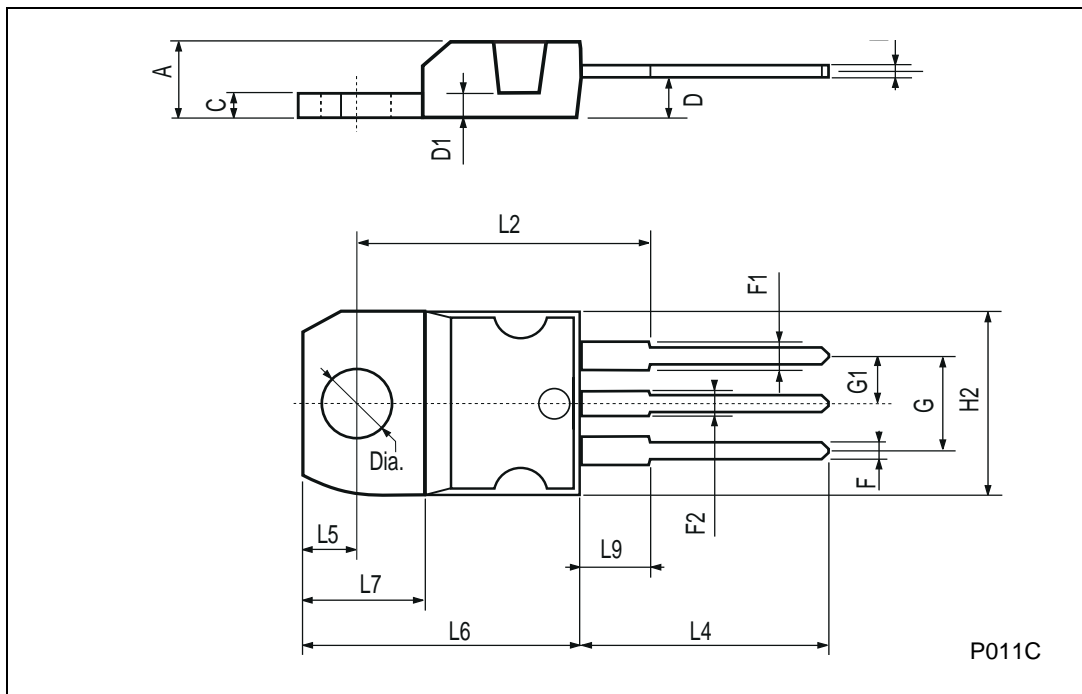

Fig. 2: Test Circuit For Inductive Load Switching (SC09920)



TO-220 MECHANICAL DATA

DIM.	mm			inch		
	MIN.	TYP.	MAX.	MIN.	TYP.	MAX.
A	4.40		4.60	0.173		0.181
C	1.23		1.32	0.048		0.051
D	2.40		2.72	0.094		0.107
D1		1.27			0.050	
E	0.49		0.70	0.019		0.027
F	0.61		0.88	0.024		0.034
F1	1.14		1.70	0.044		0.067
F2	1.14		1.70	0.044		0.067
G	4.95		5.15	0.194		0.203
G1	2.4		2.7	0.094		0.106
H2	10.0		10.40	0.393		0.409
L2		16.4			0.645	
L4	13.0		14.0	0.511		0.551
L5	2.65		2.95	0.104		0.116
L6	15.25		15.75	0.600		0.620
L7	6.2		6.6	0.244		0.260
L9	3.5		3.93	0.137		0.154
DIA.	3.75		3.85	0.147		0.151



Information furnished is believed to be accurate and reliable. However, STMicroelectronics assumes no responsibility for the consequences of use of such information nor for any infringement of patents or other rights of third parties which may result from its use. No license is granted by implication or otherwise under any patent or patent rights of STMicroelectronics. Specification mentioned in this publication are subject to change without notice. This publication supersedes and replaces all information previously supplied. STMicroelectronics products are not authorized for use as critical components in life support devices or systems without express written approval of STMicroelectronics.

The ST logo is a trademark of STMicroelectronics

© 2000 STMicroelectronics – Printed in Italy – All Rights Reserved

STMicroelectronics GROUP OF COMPANIES

Australia - Brazil - China - Finland - France - Germany - Hong Kong - India - Italy - Japan - Malaysia - Malta - Morocco -
Singapore - Spain - Sweden - Switzerland - United Kingdom - U.S.A.

<http://www.st.com>