



STGP20NB60K

N-CHANNEL 20A - 600V - TO-220

PowerMesh™ IGBT

PRELIMINARY DATA

TYPE	V _{CES}	V _{CE(sat)}	I _C
STGP20NB60K	600 V	< 2.8 V	20 A

- HIGH INPUT IMPEDANCE (VOLTAGE DRIVEN)
- LOW ON-VOLTAGE DROP (V_{cesat})
- LOW ON-LOSSES
- LOW GATE CHARGE
- HIGH CURRENT CAPABILITY
- OFF LOSSES INCLUDE TAIL CURRENT
- VERY HIGH FREQUENCY OPERATION
- SHORT CIRCUIT RATED
- LATCH CURRENT FREE OPERATION

DESCRIPTION

Using the latest high voltage technology based on a patented strip layout, STMicroelectronics has designed an advanced family of IGBTs, the PowerMESH™ IGBTs, with outstanding performances. The suffix "K" identifies a family optimized for high frequency motor control applications with short circuit withstand capability.

APPLICATIONS

- HIGH FREQUENCY MOTOR CONTROLS
- U.P.S.
- WELDING EQUIPMENTS

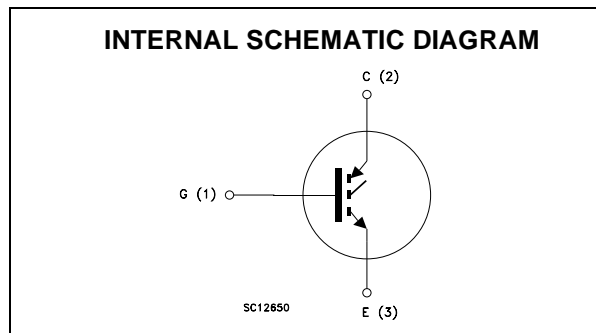
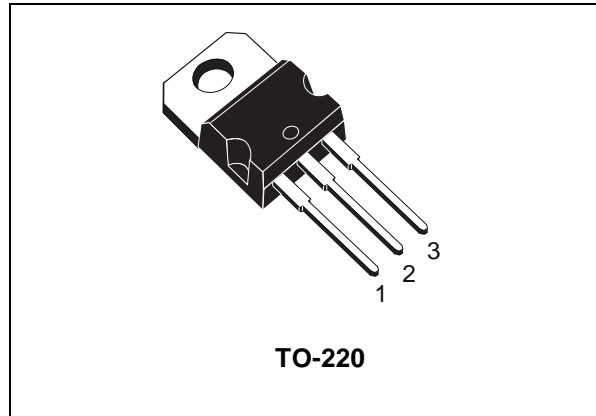

ABSOLUTE MAXIMUM RATINGS

Symbol	Parameter	Value	Unit
V _{CES}	Collector-Emitter Voltage (V _{GS} = 0)	600	V
V _{ECR}	Emitter-Collector Voltage	20	V
V _{GE}	Gate-Emitter Voltage	±20	V
I _C	Collector Current (continuous) at T _C = 25°C	40	A
I _C	Collector Current (continuous) at T _C = 100°C	20	A
I _{CM} (■)	Collector Current (pulsed)	80	A
T _{sc}	Short Circuit Withstand	10	μs
P _{TOT}	Total Dissipation at T _C = 25°C	125	W
	Derating Factor	1	W/°C
T _{stg}	Storage Temperature	-65 to 150	°C
T _j	Max. Operating Junction Temperature	150	°C

STGP20NB60K

THERMAL DATA

Rthj-case	Thermal Resistance Junction-case Max	1.0	°C/W
Rthj-amb	Thermal Resistance Junction-ambient Max	62.5	°C/W
Rthc-h	Thermal Resistance Case-heatsink Typ	0.5	°C/W

ELECTRICAL CHARACTERISTICS (TCASE = 25 °C UNLESS OTHERWISE SPECIFIED)

OFF

Symbol	Parameter	Test Conditions	Min.	Typ.	Max.	Unit
$V_{BR(CES)}$	Collectro-Emitter Breakdown Voltage	$I_C = 250 \mu A, V_{GE} = 0$	600			V
I_{CES}	Collector cut-off ($V_{GE} = 0$)	$V_{CE} = \text{Max Rating}, T_C = 25 \text{ }^\circ\text{C}$ $V_{CE} = \text{Max Rating}, T_C = 125 \text{ }^\circ\text{C}$			10 100	μA μA
I_{GES}	Gate-Emitter Leakage Current ($V_{CE} = 0$)	$V_{GE} = \pm 20V, V_{CE} = 0$			± 100	nA

ON (1)

Symbol	Parameter	Test Conditions	Min.	Typ.	Max.	Unit
$V_{GE(th)}$	Gate Threshold Voltage	$V_{CE} = V_{GE}, I_C = 250\mu A$	5		7	V
$V_{CE(sat)}$	Collector-Emitter Saturation Voltage	$V_{GE} = 15V, I_C = 20 A$ $V_{GE} = 15V, I_C = 20 A, T_J = 125^\circ C$		2.3 1.9	2.8	V V

DYNAMIC

Symbol	Parameter	Test Conditions	Min.	Typ.	Max.	Unit
g_{fs}	Forward Transconductance	$V_{CE} = 25 V, I_C = 20 A$		8		S
C_{ies}	Input Capacitance	$V_{CE} = 25V, f = 1 \text{ MHz}, V_{GE} = 0$		1300		pF
C_{oes}	Output Capacitance			200		pF
C_{res}	Reverse Transfer Capacitance			30		pF
Q_g	Total Gate Charge	$V_{CE} = 480V, I_C = 20 A,$ $V_{GE} = 15V$		90		nC
Q_{ge}	Gate-Emitter Charge			T.B.D.		nC
Q_{gc}	Gate-Collector Charge			T.B.D.		nC
t_{wsc}	Short Circuit Withstand Time	$V_{ce} = 0.5 BV_{ces}, V_{GE} = 15 V,$ $T_J = 125^\circ C, R_G = 10 \Omega$	10			μs

SWITCHING ON

Symbol	Parameter	Test Conditions	Min.	Typ.	Max.	Unit
$t_{d(on)}$	Turn-on Delay Time	$V_{CC} = 480 V, I_C = 20 A$ $R_G = 10\Omega, V_{GE} = 15 V$		20		ns
t_r	Rise Time			70		ns
$(di/dt)_{on}$	Turn-on Current Slope	$V_{CC} = 480 V, I_C = 20 A, R_G = 10\Omega$ $V_{GE} = 15 V, T_J = 125^\circ C$		350		A/ μs
Eon	Turn-on Switching Losses			300		μJ

ELECTRICAL CHARACTERISTICS (CONTINUED)**SWITCHING OFF**

Symbol	Parameter	Test Conditions	Min.	Typ.	Max.	Unit
t_c	Cross-over Time	$V_{CC} = 480 \text{ V}$, $I_C = 20 \text{ A}$, $R_{GE} = 10 \Omega$, $V_{GE} = 15 \text{ V}$		120		ns
$t_r(V_{off})$	Off Voltage Rise Time			35		ns
$t_{d(off)}$	Delay Time			130		ns
t_f	Fall Time			80		ns
$E_{off(**)}$	Turn-off Switching Loss			0.45		mJ
E_{ts}	Total Switching Loss			0.6		mJ
t_c	Cross-over Time	$V_{CC} = 480 \text{ V}$, $I_C = 20 \text{ A}$, $R_{GE} = 10 \Omega$, $V_{GE} = 15 \text{ V}$ $T_j = 125 \text{ }^\circ\text{C}$		190		ns
$t_r(V_{off})$	Off Voltage Rise Time			55		ns
$t_{d(off)}$	Delay Time			160		ns
t_f	Fall Time			150		ns
$E_{off(**)}$	Turn-off Switching Loss			0.75		mJ
E_{ts}	Total Switching Loss			1.05		mJ

Note: 1. Pulsed: Pulse duration = 300 μs , duty cycle 1.5 %.
2. Pulse width limited by max. junction temperature.
(**) Losses include Also the Tail (Jedec Standardization)

Fig. 1: Gate Charge test Circuit

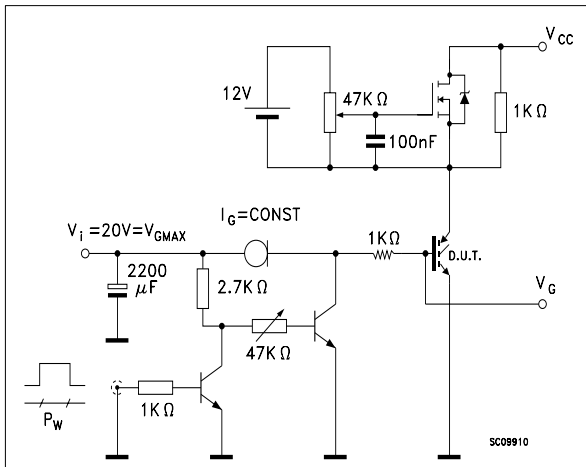
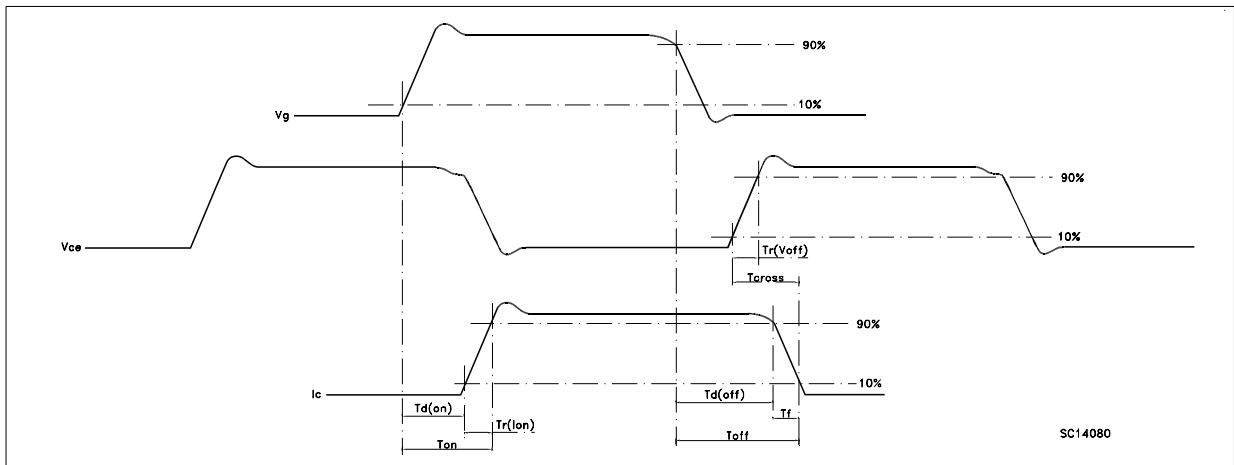
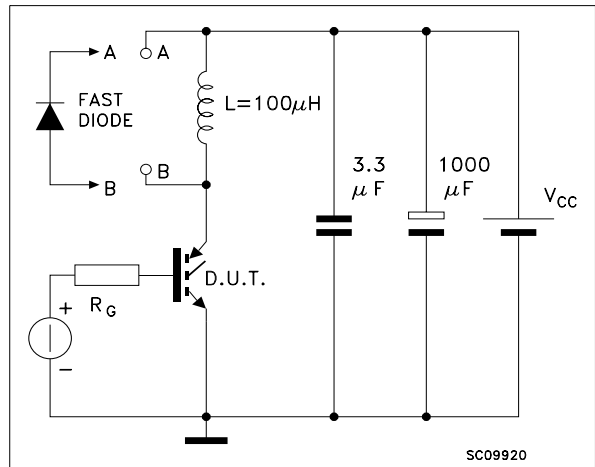
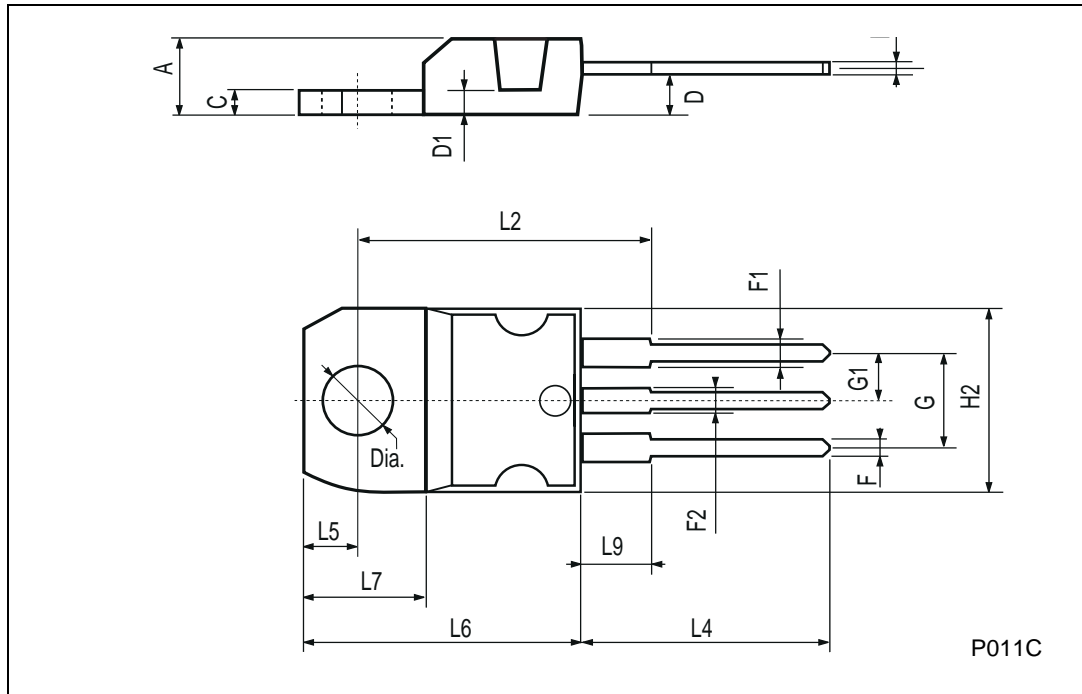

Fig. 2: Test Circuit For Inductive Load Switching



TO-220 MECHANICAL DATA

DIM.	mm			inch		
	MIN.	TYP.	MAX.	MIN.	TYP.	MAX.
A	4.40		4.60	0.173		0.181
C	1.23		1.32	0.048		0.051
D	2.40		2.72	0.094		0.107
D1		1.27			0.050	
E	0.49		0.70	0.019		0.027
F	0.61		0.88	0.024		0.034
F1	1.14		1.70	0.044		0.067
F2	1.14		1.70	0.044		0.067
G	4.95		5.15	0.194		0.203
G1	2.4		2.7	0.094		0.106
H2	10.0		10.40	0.393		0.409
L2		16.4			0.645	
L4	13.0		14.0	0.511		0.551
L5	2.65		2.95	0.104		0.116
L6	15.25		15.75	0.600		0.620
L7	6.2		6.6	0.244		0.260
L9	3.5		3.93	0.137		0.154
DIA.	3.75		3.85	0.147		0.151



Information furnished is believed to be accurate and reliable. However, STMicroelectronics assumes no responsibility for the consequences of use of such information nor for any infringement of patents or other rights of third parties which may result from its use. No license is granted by implication or otherwise under any patent or patent rights of STMicroelectronics. Specification mentioned in this publication are subject to change without notice. This publication supersedes and replaces all information previously supplied. STMicroelectronics products are not authorized for use as critical components in life support devices or systems without express written approval of STMicroelectronics.

The ST logo is a trademark of STMicroelectronics

© 2000 STMicroelectronics – Printed in Italy – All Rights Reserved
STMicroelectronics GROUP OF COMPANIES

Australia - Brazil - China - Finland - France - Germany - Hong Kong - India - Italy - Japan - Malaysia - Malta - Morocco -
Singapore - Spain - Sweden - Switzerland - United Kingdom - U.S.A.

<http://www.st.com>