



STS25NH3LL

N-CHANNEL 30V - 0.0027Ω - 25A SO-8 STripFET™ III MOSFET FOR DC-DC CONVERSION

PRELIMINARY DATA

TYPE	V _{DSS}	R _{DS(on)}	I _D
STS25NH3LL	30 V	< 0.0035Ω	25 A

- TYPICAL R_{DS(on)} = 0.0027Ω
- OPTIMAL R_{DS(ON)} x Q_g TRADE-OFF @4.5V
- CONDUCTION LOSSES REDUCED
- SWITCHING LOSSES REDUCED
- WORLD INDUSTRY'S LOWEST ON-RESISTANCE

DESCRIPTION

The **STS25NH3LL** utilizes the latest advanced design rules of ST's proprietary STripFET™ technology. This novel 0.6μ process coupled to unique metallization techniques realizes the most advanced low voltage MOSFET in SO-8 ever produced. It is therefore suitable for the most demanding DC-DC converter applications where high efficiency is to be achieved at high output current.

APPLICATIONS

- DC-DC CONVERTERS FOR TELECOM AND NOTEBOOK CPU CORE
- SYNCHRONOUS RECTIFIER

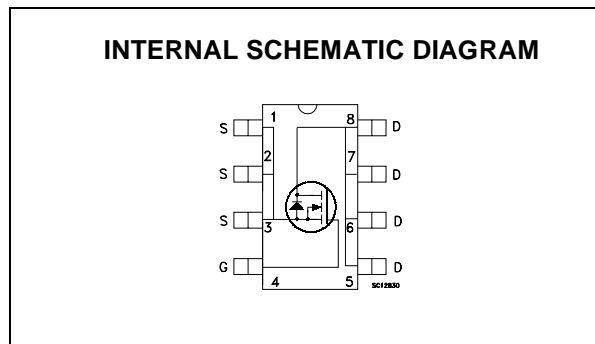
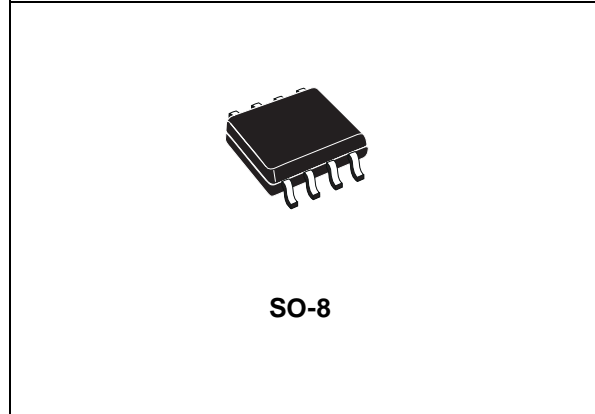

ABSOLUTE MAXIMUM RATINGS

Symbol	Parameter	Value	Unit
V _{DS}	Drain-source Voltage (V _{GS} = 0)	30	V
V _{DGR}	Drain-gate Voltage (R _{GS} = 20 kΩ)	30	V
V _{GS}	Gate- source Voltage	± 18	V
I _D	Drain Current (continuous) at T _A = 25°C	25	A
	Drain Current (continuous) at T _A = 100°C	18	A
I _{DM} (●)	Drain Current (pulsed)	100	A
P _{TOT}	Total Dissipation at T _A = 25°C	3.2	W

(●) Pulse width limited by safe operating area

STS25NH3LL

THERMAL DATA

Rthj-amb	(*) Thermal Resistance Junction-ambient Max	47	°C/W
Rthj-lead	Thermal Resistance Junction-leads Max	16	°C/W
T _j	Max. Operating Junction Temperature	-55 to 175	°C
T _{stg}	Storage Temperature		

(*) When mounted on 1 inch² FR4 Board, 2 oz of Cu, t ≤ 10 sec.

ELECTRICAL CHARACTERISTICS (T_J = 25 °C UNLESS OTHERWISE SPECIFIED)

OFF

Symbol	Parameter	Test Conditions	Min.	Typ.	Max.	Unit
V _{(BR)DSS}	Drain-source Breakdown Voltage	I _D = 250 μA, V _{GS} = 0	30			V
I _{DSS}	Zero Gate Voltage Drain Current (V _{GS} = 0)	V _{DS} = Max Rating V _{DS} = Max Rating, T _C = 125 °C			1 10	μA μA
I _{GSS}	Gate-body Leakage Current (V _{DS} = 0)	V _{GS} = ± 18V			±100	nA

ON (1)

Symbol	Parameter	Test Conditions	Min.	Typ.	Max.	Unit
V _{GS(th)}	Gate Threshold Voltage	V _{DS} = V _{GS} , I _D = 250μA	1			V
R _{DS(on)}	Static Drain-source On Resistance	V _{GS} = 10 V, I _D = 12 A V _{GS} = 4.5 V, I _D = 12 A		0.0027 0.0035	0.0035 0.0050	Ω Ω

DYNAMIC

Symbol	Parameter	Test Conditions	Min.	Typ.	Max.	Unit
g _{fs} (1)	Forward Transconductance	V _{DS} = 15V, I _D = 12 A		30		S
C _{iss}	Input Capacitance	V _{DS} = 25 V, f = 1 MHz, V _{GS} = 0		4450		pF
C _{oss}	Output Capacitance			655		pF
C _{rss}	Reverse Transfer Capacitance			50		pF

ELECTRICAL CHARACTERISTICS (CONTINUED)

SWITCHING ON

Symbol	Parameter	Test Conditions	Min.	Typ.	Max.	Unit
$t_{d(on)}$	Turn-on Delay Time	$V_{DD} = 15\text{ V}$, $I_D = 12.5\text{ A}$ $R_G = 4.7\Omega$, $V_{GS} = 10\text{ V}$ (see test circuit, Figure 1)		18		ns
t_r	Rise Time			50		ns
Q_g Q_{gs} Q_{gd}	Total Gate Charge Gate-Source Charge Gate-Drain Charge	$V_{DD} = 15\text{ V}$, $I_D = 25\text{ A}$, $V_{GS} = 5\text{ V}$ (see test circuit, Figure 2)		32 12.5 10	43	nC nC nC

SWITCHING OFF

Symbol	Parameter	Test Conditions	Min.	Typ.	Max.	Unit
$t_{d(off)}$	Turn-off-Delay Time	$V_{DD} = 15\text{ V}$, $I_D = 12.5\text{ A}$, $R_G = 4.7\Omega$, $V_{GS} = 10\text{ V}$ (see test circuit, Figure 1)		75		ns
t_f	Fall Time			8		ns

SOURCE DRAIN DIODE

Symbol	Parameter	Test Conditions	Min.	Typ.	Max.	Unit
I_{SD}	Source-drain Current				25	A
$I_{SDM(2)}$	Source-drain Current (pulsed)				100	A
$V_{SD(1)}$	Forward On Voltage	$I_{SD} = 25\text{ A}$, $V_{GS} = 0$			1.2	V
t_{rr} Q_{rr} I_{RRM}	Reverse Recovery Time Reverse Recovery Charge Reverse Recovery Current	$I_{SD} = 25\text{ A}$, $di/dt = 100\text{ A}/\mu\text{s}$, $V_{DD} = 25\text{ V}$, $T_j = 150^\circ\text{C}$ (see test circuit, Figure 3)		32 34 2.1		ns nC A

Note: 1. Pulsed: Pulse duration = 300 μs , duty cycle 1.5 %.
2. Pulse width limited by safe operating area.

Fig. 1: Switching Times Test Circuit For Resistive Load

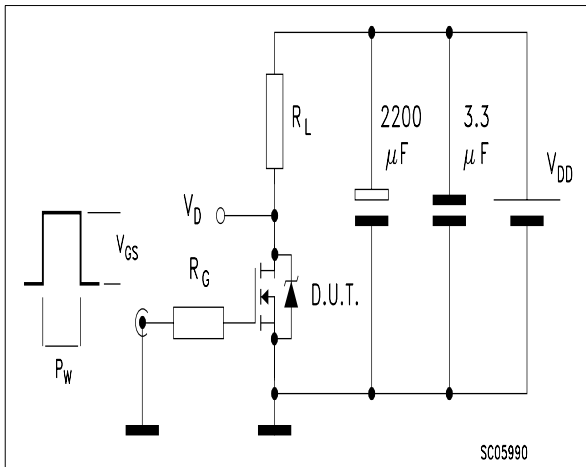

Fig. 2: Gate Charge test Circuit

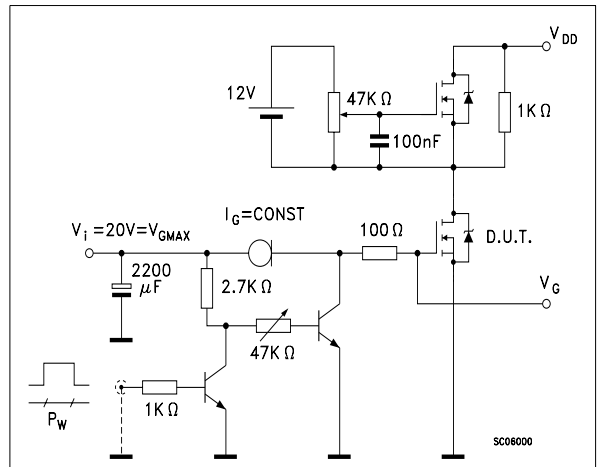
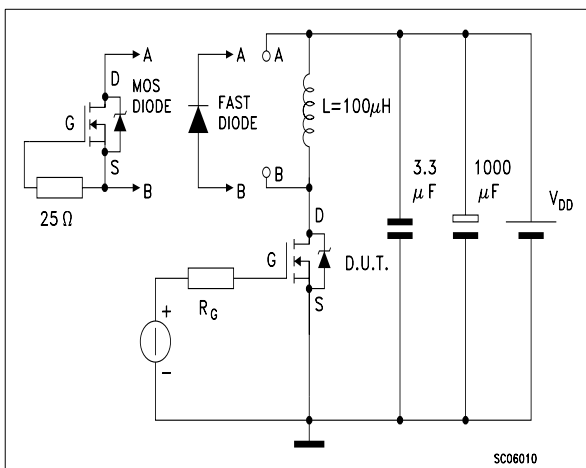
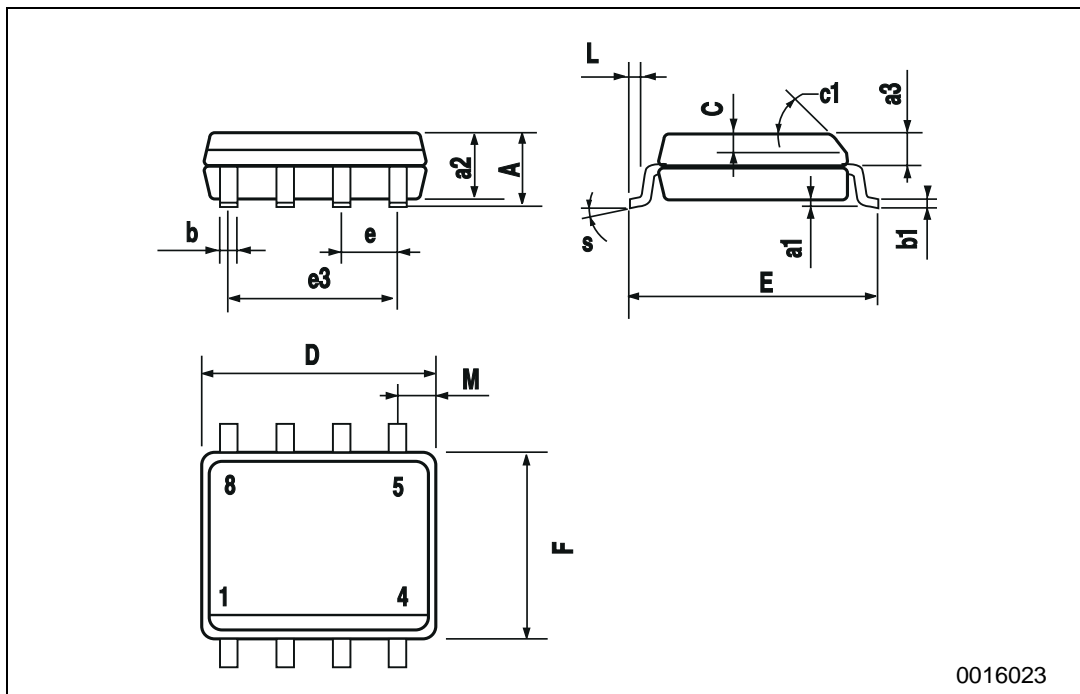

Fig. 3: Test Circuit For Diode Recovery Behaviour



SO-8 MECHANICAL DATA

DIM.	mm			inch		
	MIN.	TYP.	MAX.	MIN.	TYP.	MAX.
A			1.75			0.068
a1	0.1		0.25	0.003		0.009
a2			1.65			0.064
a3	0.65		0.85	0.025		0.033
b	0.35		0.48	0.013		0.018
b1	0.19		0.25	0.007		0.010
C	0.25		0.5	0.010		0.019
c1	45 (typ.)					
D	4.8		5.0	0.188		0.196
E	5.8		6.2	0.228		0.244
e		1.27			0.050	
e3		3.81			0.150	
F	3.8		4.0	0.14		0.157
L	0.4		1.27	0.015		0.050
M			0.6			0.023
S	8 (max.)					



Information furnished is believed to be accurate and reliable. However, STMicroelectronics assumes no responsibility for the consequences of use of such information nor for any infringement of patents or other rights of third parties which may result from its use. No license is granted by implication or otherwise under any patent or patent rights of STMicroelectronics. Specifications mentioned in this publication are subject to change without notice. This publication supersedes and replaces all information previously supplied. STMicroelectronics products are not authorized for use as critical components in life support devices or systems without express written approval of STMicroelectronics.

© The ST logo is a registered trademark of STMicroelectronics

© 2002 STMicroelectronics - Printed in Italy - All Rights Reserved
STMicroelectronics GROUP OF COMPANIES

Australia - Brazil - Canada - China - Finland - France - Germany - Hong Kong - India - Israel - Italy - Japan - Malaysia - Malta - Morocco
Singapore - Spain - Sweden - Switzerland - United Kingdom - United States.

© <http://www.st.com>