

POWER SCHOTTKY RECTIFIER

Table 1: Main Product Characteristics

$I_{F(AV)}$	1 A
V_{RRM}	200 V
T_j (max)	175°C
V_F (max)	0.78 V
t_{rr} (max)	20 ns

FEATURES AND BENEFITS

- Very low conduction losses
- Negligible switching losses
- Low forward and reverse recovery times
- High junction temperature

DESCRIPTION

The STTH102, which is using ST's new 200V planar technology, is specially suited for switching mode base drive and transistor circuits.

The device is also intended for use as a free wheeling diode in power supplies and other power switching applications.

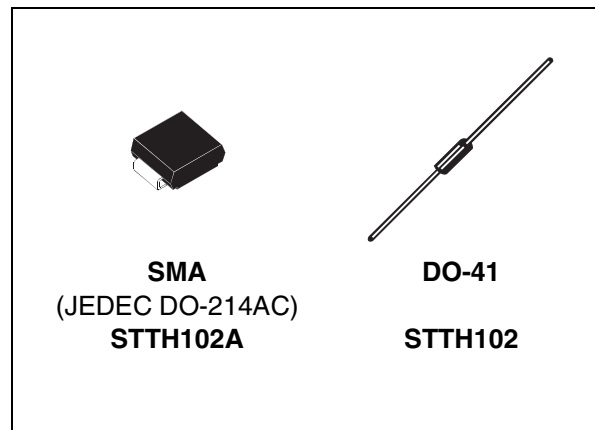

Table 2: Order Codes

Part Number	Marking
STTH102A	U12
STTH102	STTH102
STTH102RL	STTH102

Table 3: Absolute Ratings (limiting values)

Symbol	Parameter		Value	Unit	
V_{RRM}	Repetitive peak reverse voltage		200	V	
$I_{F(AV)}$	Average forward current	SMA	$T_L = 148^\circ\text{C}$ $\delta = 0.5$	1	A
		DO-41	$T_L = 130^\circ\text{C}$ $\delta = 0.5$		
I_{FSM}	Surge non repetitive forward current	SMA	$t_p = 10$ ms Sinusoidal	40	A
		DO-41		50	
T_{stg}	Storage temperature range		-65 to + 175	°C	
T_j	Maximum operating junction temperature		175	°C	
dV/dt	Critical rate of rise of reverse voltage		10000	V/ μ s	

Table 4: Thermal Resistance

Symbol	Parameter		Value	Unit
$R_{th(j-l)}$	Junction to lead	SMA	30	$^{\circ}\text{C/W}$
		Lead length = 10 mm DO-41	50	

Table 5: Static Electrical Characteristics

Symbol	Parameter	Tests conditions		Min.	Typ	Max.	Unit
I_R^*	Reverse leakage current	$T_j = 25^{\circ}\text{C}$	$V_R = V_{RRM}$			1	μA
		$T_j = 125^{\circ}\text{C}$		1	25		
V_F^{**}	Forward voltage drop	$T_j = 25^{\circ}\text{C}$	$I_F = 700\text{ mA}$ (SMA)			0.90	V
			$I_F = 1\text{ A}$			0.97	
		$T_j = 125^{\circ}\text{C}$	$I_F = 1\text{ A}$		0.68	0.78	

Pulse test: * $t_p = 5\text{ ms}$, $\delta < 2\%$
 ** $t_p = 380\text{ }\mu\text{s}$, $\delta < 2\%$

To evaluate the conduction losses use the following equation: $P = 0.65 \times I_{F(AV)} + 0.130 I_{F(RMS)}^2$

Figure 1: Average forward power dissipation versus average forward current (SMA)

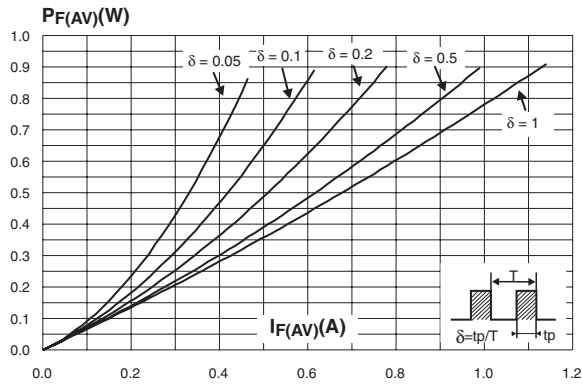

Figure 2: Average forward power dissipation versus average forward current (DO-41)

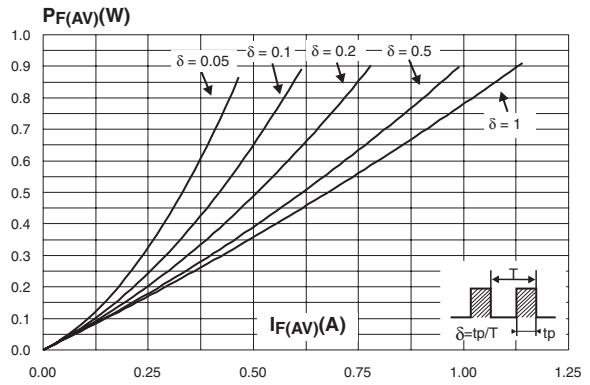

Figure 3: Average forward current versus ambient temperature (delta = 0.5) (SMA)

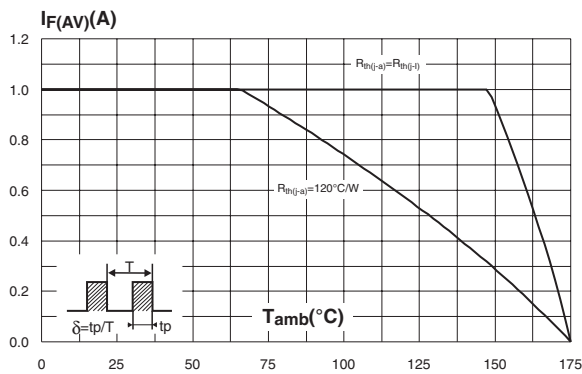

Figure 4: Average forward current versus ambient temperature (delta = 0.5) (DO-41)

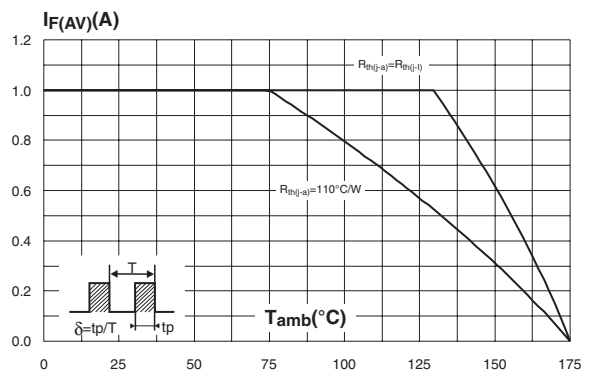

Figure 5: Relative variation of thermal impedance junction to ambient versus pulse duration (epoxy printed circuit board, e(Cu)=35μm, recommended pad layout) (SMA)

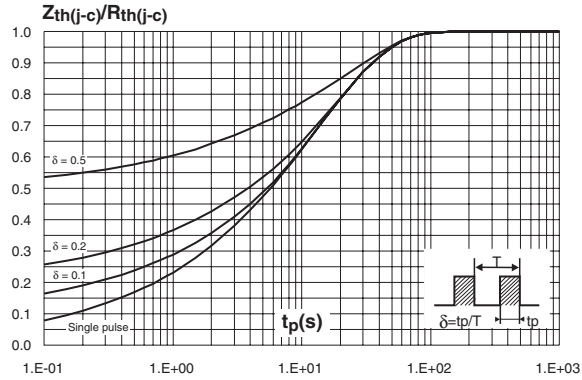

Figure 6: Relative variation of thermal impedance junction to ambient versus pulse duration (DO-41)

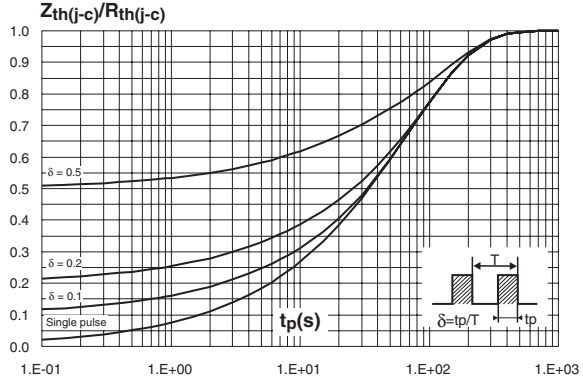

Figure 7: Forward voltage drop versus forward current

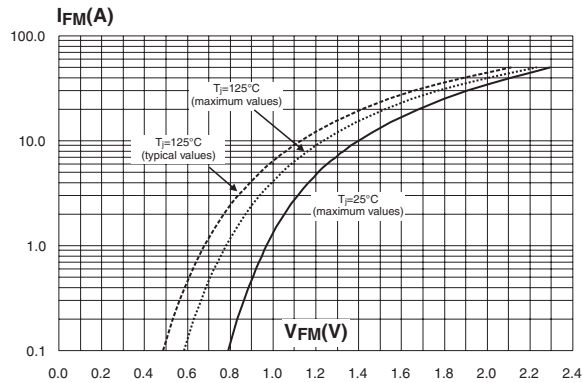

Figure 8: Junction capacitance versus reverse voltage applied (typical values)

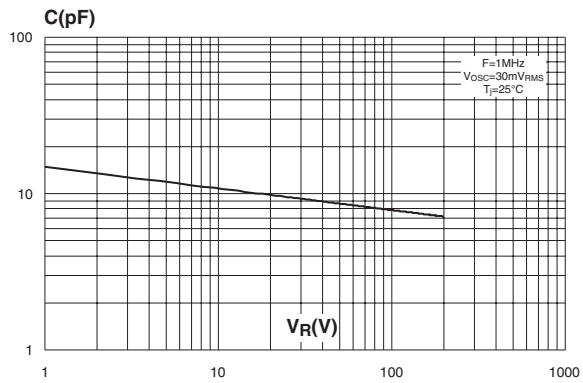

Figure 9: Reverse recovery time versus dIF/dt (90% confidence)

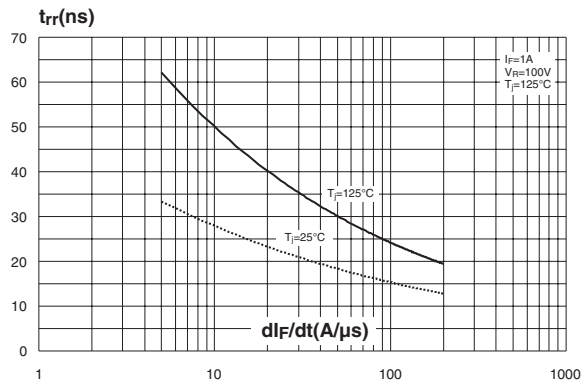

Figure 10: Peak recovery current versus dIF/dt (90% confidence)

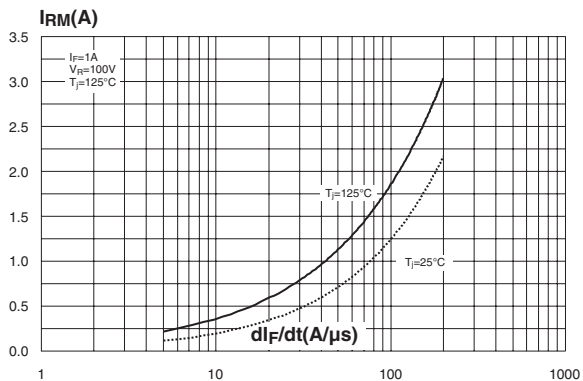

Figure 11: Reverse recovery charges versus dl_F/dt (90% confidence)

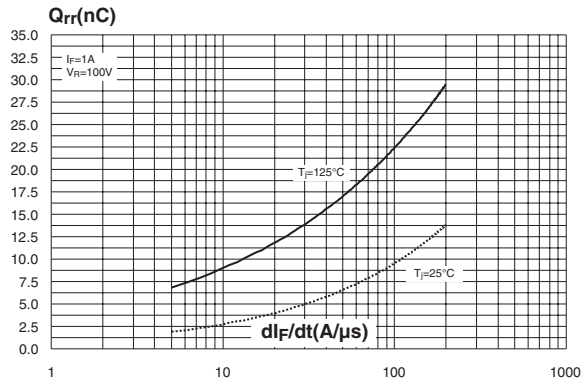

Figure 12: Relative variations of dynamic parameters versus junction temperature

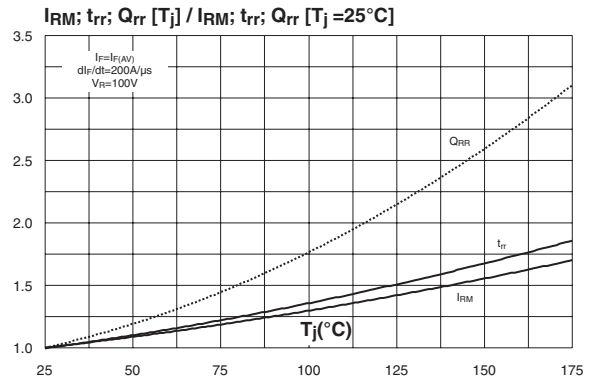

Figure 13: Thermal resistance junction to ambient versus copper surface under each lead (Epoxy printed circuit board FR4, copper thickness: 35 μ m) (SMA)

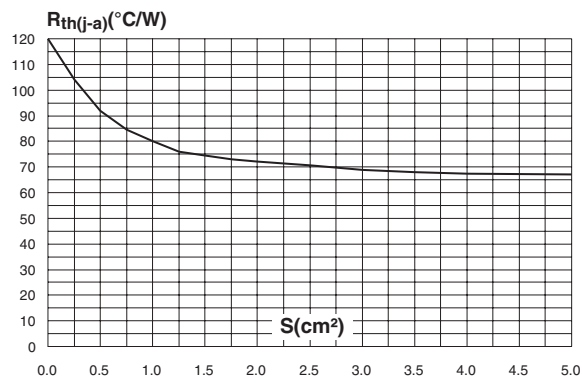

Figure 14: Thermal resistance versus lead length (DO-41)

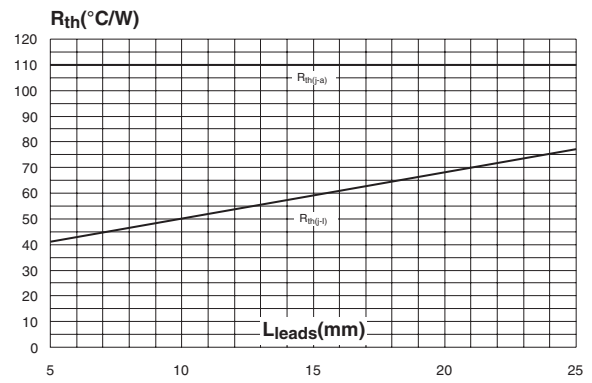

Figure 15: SMA Package Mechanical Data

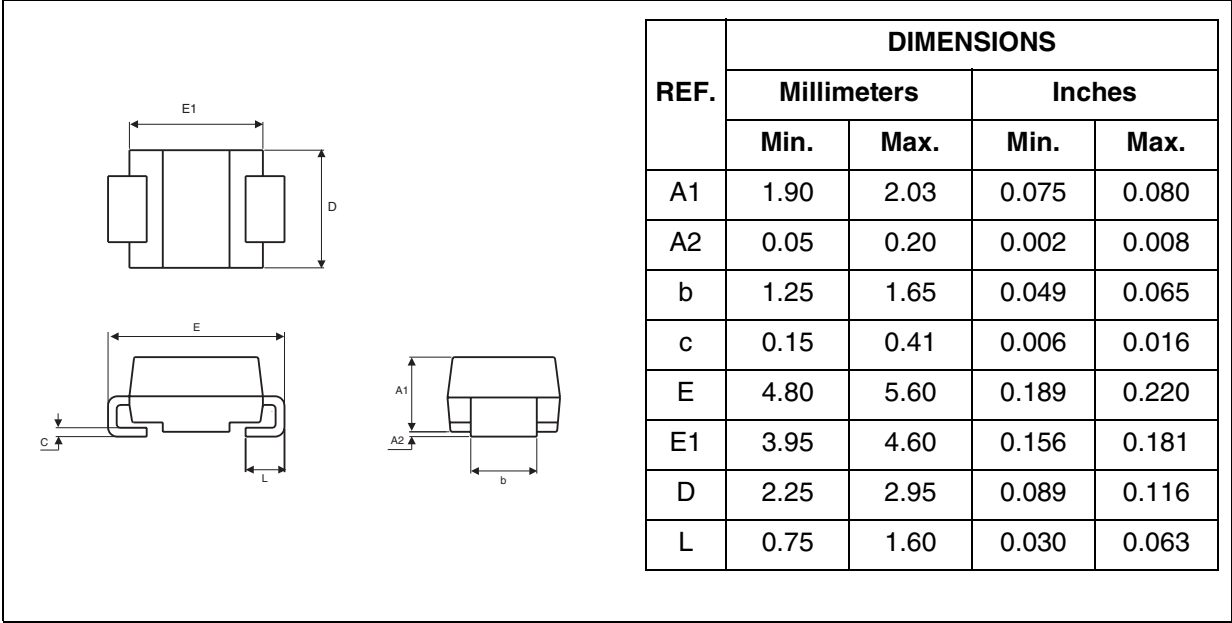

Figure 16: SMA Foot Print Dimensions (in millimeters)

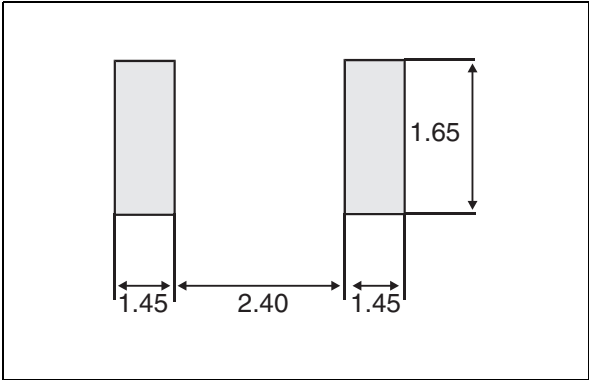

Figure 17: DO-41 Package Mechanical Data

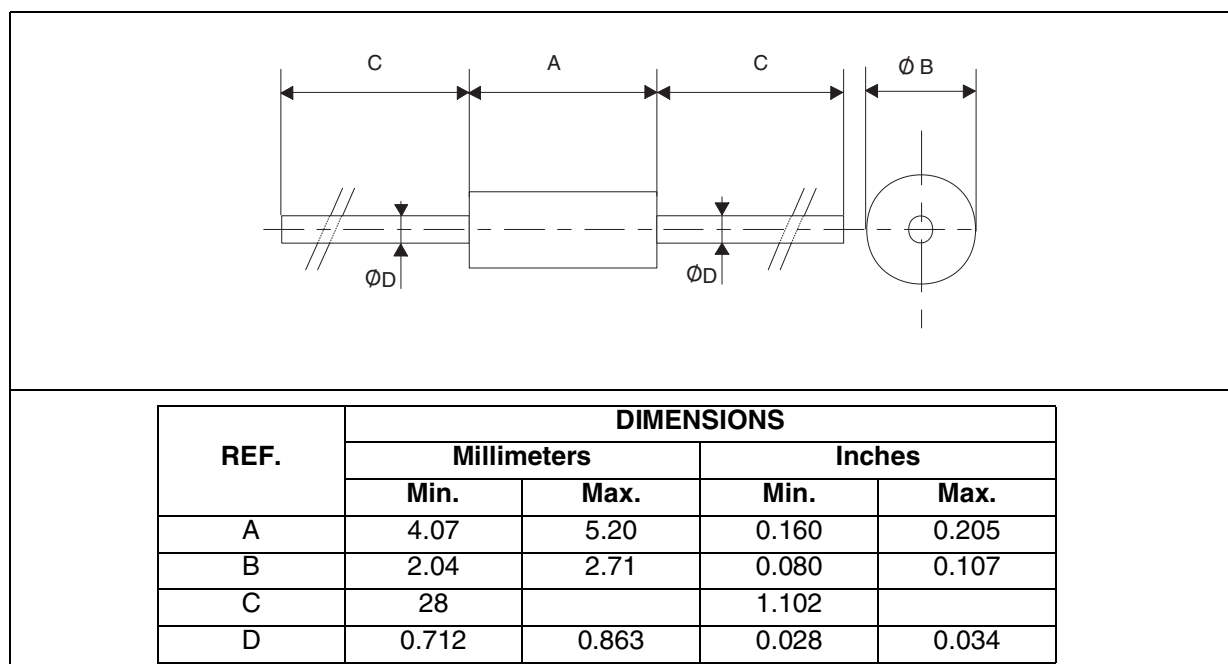

Table 6: Ordering Information

Ordering type	Marking	Package	Weight	Base qty	Delivery mode
STTH102A	U12	SMA	0.068 g	5000	Tape & reel
STTH102	STTH102	DO-41	0.34 g	2000	Ammopack
STTH102RL	STTH102	DO-41	0.34 g	5000	Tape & reel

- Band indicates cathode
- Epoxy meets UL94, V0

Table 7: Revision History

Date	Revision	Description of Changes
Jul-2003	2A	Last update.
Aug-2004	3	1. SMA package dimensions update. Reference A1 max. changed from 2.70mm (0.106inc.) to 2.03mm (0.080). 2. SMA and DO-41 datasheets merged

Information furnished is believed to be accurate and reliable. However, STMicroelectronics assumes no responsibility for the consequences of use of such information nor for any infringement of patents or other rights of third parties which may result from its use. No license is granted by implication or otherwise under any patent or patent rights of STMicroelectronics. Specifications mentioned in this publication are subject to change without notice. This publication supersedes and replaces all information previously supplied. STMicroelectronics products are not authorized for use as critical components in life support devices or systems without express written approval of STMicroelectronics.

The ST logo is a registered trademark of STMicroelectronics.
All other names are the property of their respective owners

© 2004 STMicroelectronics - All rights reserved

STMicroelectronics group of companies

Australia - Belgium - Brazil - Canada - China - Czech Republic - Finland - France - Germany - Hong Kong - India - Israel - Italy - Japan - Malaysia - Malta - Morocco - Singapore - Spain - Sweden - Switzerland - United Kingdom - United States of America
www.st.com