



# STW29NK50Z

## N-CHANNEL 500 V - 0.105Ω - 31A TO-247 Zener-Protected SuperMESH™ MOSFET

**Table 1: General Features**

TYPE	V <sub>DSS</sub>	R <sub>DS(on)</sub>	I <sub>D</sub>	P <sub>W</sub>
STW29NK50Z	500 V	< 0.13 Ω	31 A	350 W

- TYPICAL R<sub>DS(on)</sub> = 0.105 Ω
- EXTREMELY HIGH dv/dt CAPABILITY
- 100% AVALANCHE TESTED
- GATE CHARGE MINIMIZED
- VERY LOW INTRINSIC CAPACITANCES
- VERY GOOD MANUFACTURING REPEATIBILITY

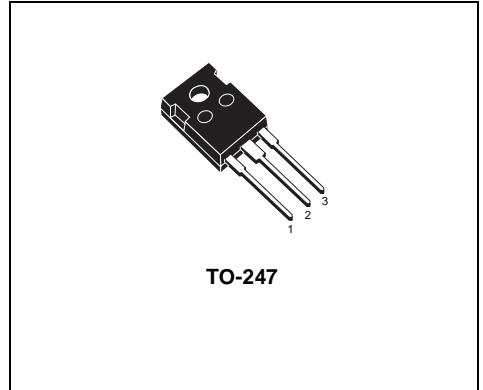
### DESCRIPTION

The SuperMESH™ series is obtained through an extreme optimization of ST's well established strip-based PowerMESH™ layout. In addition to pushing on-resistance significantly down, special care is taken to ensure a very good dv/dt capability for the most demanding application. Such series complements ST full range of high vltage MOSFETs including revolutionary MDmesh™ products.

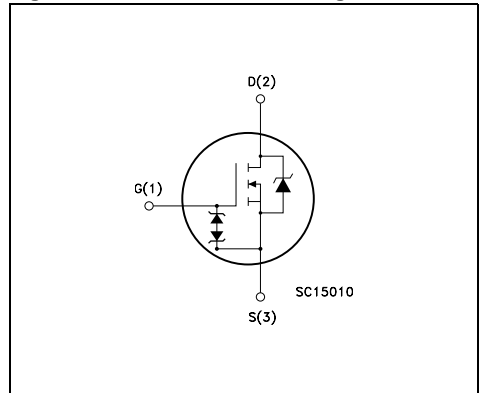
### APPLICATIONS

- HIGH CURRENT, HIGH SPEED SWITCHING
- IDEAL FOR OFF-LINE POWER SUPPLIES
- WELDING MACHINES
- LIGHTING

**Figure 1: Package**



**Figure 2: Internal Schematic Diagram**



**Table 2: Order Codes**

PART NUMBER	MARKING	PACKAGE	PACKAGING
STW29NK50Z	W29NK50Z	TO-247	TUBE

**Table 3: Absolute Maximum ratings**

Symbol	Parameter	Value	Unit
V <sub>DS</sub>	Drain-source Voltage (V <sub>GS</sub> = 0)	500	V
V <sub>DGR</sub>	Drain-gate Voltage (R <sub>GS</sub> = 20 KΩ)	500	V
V <sub>GS</sub>	Gate- source Voltage	± 30	V
I <sub>D</sub>	Drain Current (continuous) at T <sub>C</sub> = 25°C	31	A
I <sub>D</sub>	Drain Current (continuous) at T <sub>C</sub> = 100°C	19.5	A
I <sub>DM</sub> (*)	Drain Current (pulsed)	124	A
P <sub>TOT</sub>	Total Dissipation at T <sub>C</sub> = 25°C	350	W
	Derating Factor	2.77	W/°C
V <sub>ESD(G-S)</sub>	Gate source ESD (HBM-C = 100pF, R = 1.5 KΩ)	6000	V
dv/dt (1)	Peak Diode Recovery voltage slope	4.5	V/ns
T <sub>stg</sub> T <sub>J</sub>	Storage Temperature Operating Junction Temperature	-55 to 150	°C

(\*) Pulse width limited by safe operating area

(1) I<sub>SD</sub> ≤ 31 A, di/dt ≤ 200 A/μs, V<sub>DD</sub> ≤ V<sub>(BR)DSS</sub>, T<sub>J</sub> ≤ T<sub>JMAX</sub>

**Table 4: Thermal Data**

R <sub>thj-case</sub>	Thermal Resistance Junction-case Max	0.36	°C/W
R <sub>thj-amb</sub> T <sub>I</sub>	Thermal Resistance Junction-ambient Max Maximum Lead Temperature For Soldering Purpose	50 300	°C/W °C

**Table 5: Avalanche Characteristics**

Symbol	Parameter	Max Value	Unit
I <sub>AR</sub>	Avalanche Current, Repetitive or Not-Repetitive (pulse width limited by T <sub>J</sub> max)	31	A
E <sub>AS</sub>	Single Pulse Avalanche Energy (starting T <sub>J</sub> = 25 °C, I <sub>D</sub> = I <sub>AR</sub> , V <sub>DD</sub> = 50 V)	550	mJ

**Table 6: Gate-Source Zener Diode**

Symbol	Parameter	Test Condition	Min.	Typ.	Max	Unit
BV <sub>GSO</sub>	Gate-Source Breakdown Voltage	I <sub>gs</sub> = ± 1mA (Open Drain)	30			A

**PROTECTION FEATURES OF GATE-TO-SOURCE ZENER DIODES**

The built-in back-to-back Zener diodes have specifically been designed to enhance not only the device's ESD capability, but also to make them safely absorb possible voltage transients that may occasionally be applied from gate to source. In this respect the Zener voltage is appropriate to achieve an efficient and cost-effective intervention to protect the device's integrity. These integrated Zener diodes thus avoid the usage of external components.

**TABLE 7: ELECTRICAL CHARACTERISTICS** ( $T_{CASE} = 25^{\circ}C$  UNLESS OTHERWISE SPECIFIED)

On /Off

Symbol	Parameter	Test Conditions	Min.	Typ.	Max.	Unit
$V_{(BR)DSS}$	Drain-source Breakdown Voltage	$I_D = 1 \text{ mA}, V_{GS} = 0$	500			S
$I_{DSS}$	Zero Gate Voltage Drain Current ( $V_{GS} = 0$ )	$V_{DS} = \text{Max Rating}$ $V_{DS} = \text{Max Rating}, T_C = 125^{\circ}C$			1 50	$\mu A$ $\mu A$
$I_{GSS}$	Gate-body Leakage Current ( $V_{DS} = 0$ )	$V_{GS} = \pm 20 \text{ V}$			$\pm 10$	$\mu A$
$V_{GS(th)}$	Gate Threshold Voltage	$V_{DS} = V_{GS}, I_D = 150 \mu A$	3	3.75	4.5	V
$R_{DS(on)}$	Static Drain-source On Resistance	$V_{GS} = 10 \text{ V}, I_D = 15.5 \text{ A}$		0.105	0.13	$\Omega$

**Table 8: Dynamic**

Symbol	Parameter	Test Conditions	Min.	Typ.	Max.	Unit
$g_{fs} (1)$	Forward Transconductance	$V_{DS} = 15 \text{ V}, I_D = 15.5 \text{ A}$		24		S
$C_{iss}$ $C_{oss}$ $C_{riss}$	Input Capacitance Output Capacitance Reverse Transfer Capacitance	$V_{DS} = 25 \text{ V}, f = 1 \text{ MHz}, V_{GS} = 0$		6110 697 166		pF pF pF
$t_{d(on)}$ $t_r$ $t_{d(off)}$ $t_f$	Turn-on Delay Time Rise Time Turn-off-Delay Time Fall Time	$V_{DD} = 250 \text{ V}, I_D = 15 \text{ A},$ $R_G = 4.7 \Omega, V_{GS} = 10 \text{ V}$ (Resistive Load see Figure 17)		44.5 41 129 33		ns ns ns ns
$Q_g$ $Q_{gs}$ $Q_{gd}$	Total Gate Charge Gate-Source Charge Gate-Drain Charge	$V_{DD} = 400 \text{ V}, I_D = 30 \text{ A},$ $V_{GS} = 10 \text{ V}$		190 35.5 111	266	nC nC nC

**Table 9: Source Drain Diode**

Symbol	Parameter	Test Conditions	Min.	Typ.	Max.	Unit
$I_{SD}$ $I_{SDM} (2)$	Source-drain Current Source-drain Current (pulsed)				31 124	A A
$V_{SD} (1)$	Forward On Voltage	$I_{SD} = 31 \text{ A}, V_{GS} = 0$			1.6	V
$t_{rr}$ $Q_{rr}$ $I_{RRM}$	Reverse Recovery Time Reverse Recovery Charge Reverse Recovery Current	$I_{SD} = 30 \text{ A}, di/dt = 100 \text{ A}/\mu s$ $V_{DD} = 44.8 \text{ V}, T_j = 25^{\circ}C$ (see test circuit Figure 5)		436 6.1 28		ns $\mu C$ A
$t_{rr}$ $Q_{rr}$ $I_{RRM}$	Reverse Recovery Time Reverse Recovery Charge Reverse Recovery Current	$I_{SD} = 30 \text{ A}, di/dt = 100 \text{ A}/\mu s$ $V_{DD} = 44.8 \text{ V}, T_j = 150^{\circ}C$ (see test circuit Figure 5)		500 7.5 30		ns $\mu C$ A

(1) Pulsed: Pulse duration = 300  $\mu s$ , duty cycle 1.5 %.

(2) Pulse width limited by safe operating area.

Figure 3: Safe Operating Area

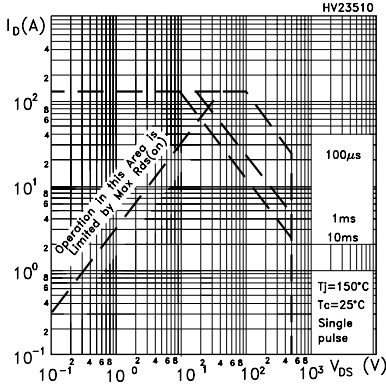


Figure 4: Output Characteristics

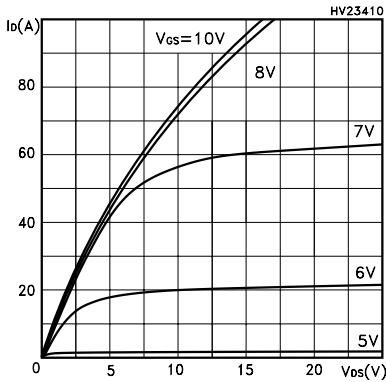


Figure 5: Transconductance

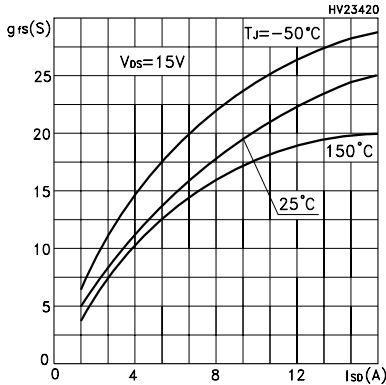


Figure 6: Thermal Impedance

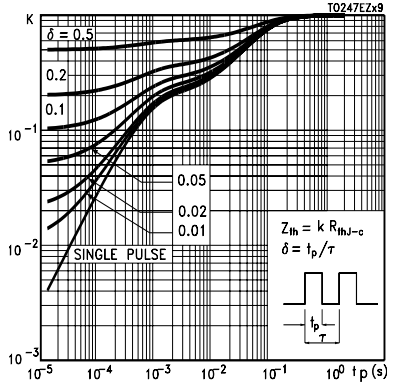


Figure 7: Transfer Characteristics

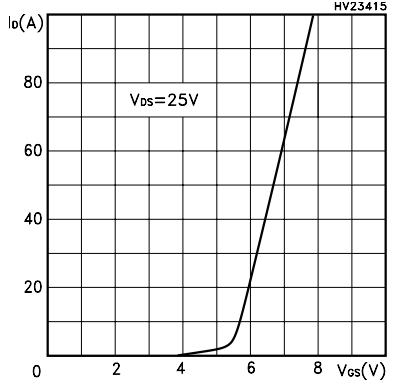


Figure 8: Static Drain-source On Resistance

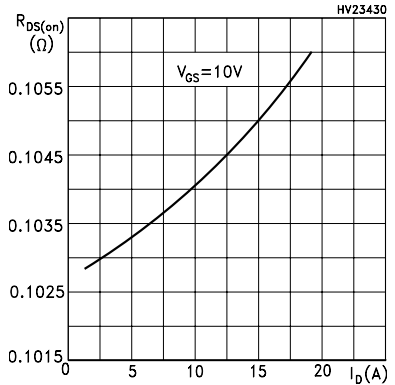


Figure 9: Gate Charge vs Gate-source Voltage

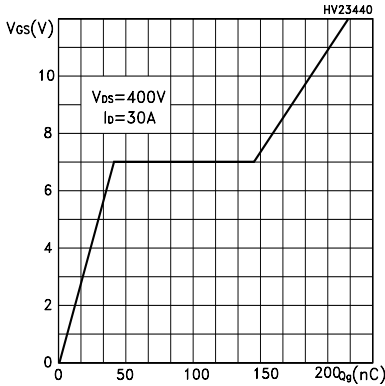


Figure 10: Normalized Gate Threshold Voltage vs Temperature

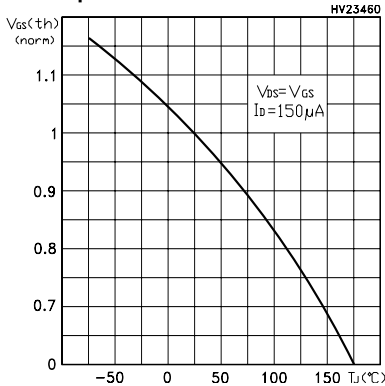


Figure 11: Dource-Drain Diode Forward Characteristics

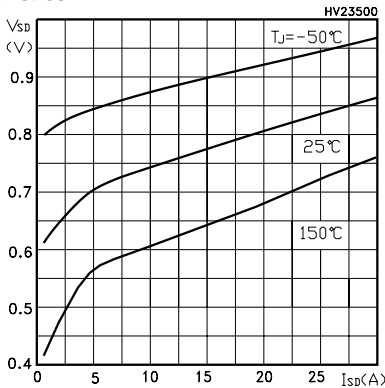


Figure 12: Capacitance Variations

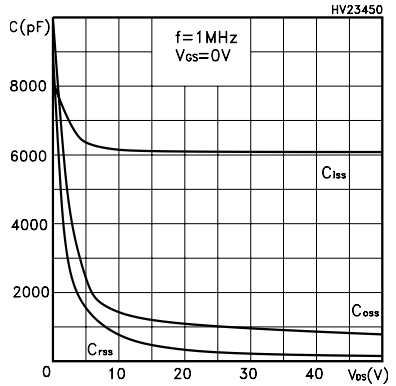


Figure 13: Normalized On Resistance vs Temperature

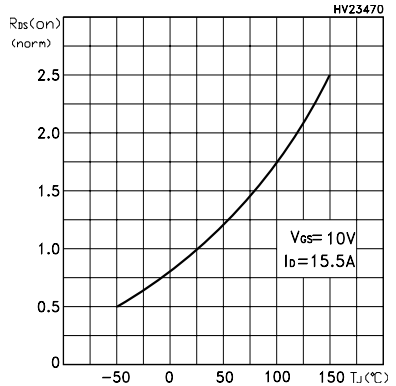


Figure 14: Normalized BV<sub>DSS</sub> vs Temperature

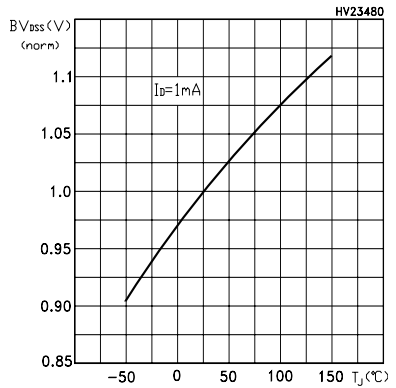
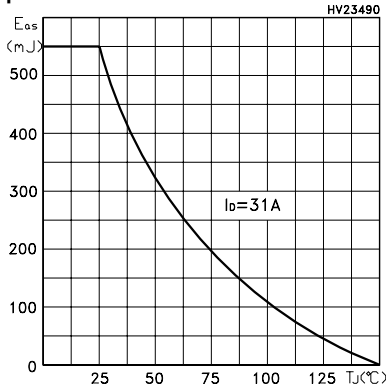
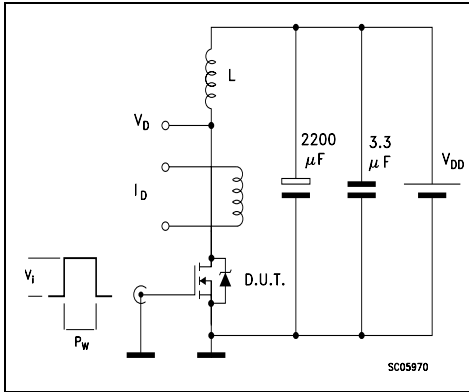


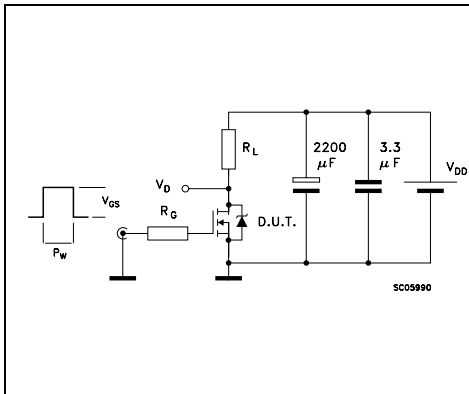
Figure 15: Maximum Avalanche Energy vs Temperature



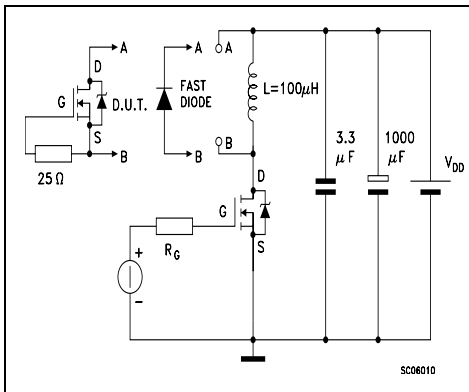
**Figure 16: Unclamped Inductive Load Test Circuit**



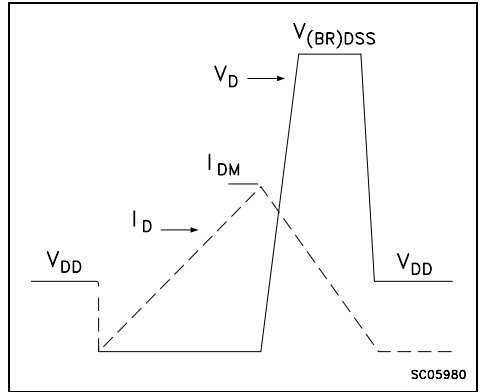
**Figure 17: Switching Times Test Circuit For Resistive Load**



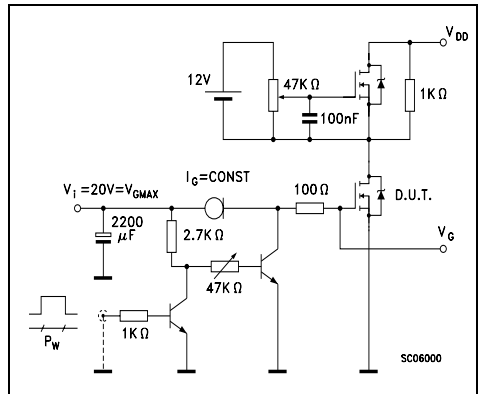
**Figure 18: Test Circuit For Inductive Load Switching and Diode Recovery Times**



**Figure 19: Unclamped Inductive Waferform**

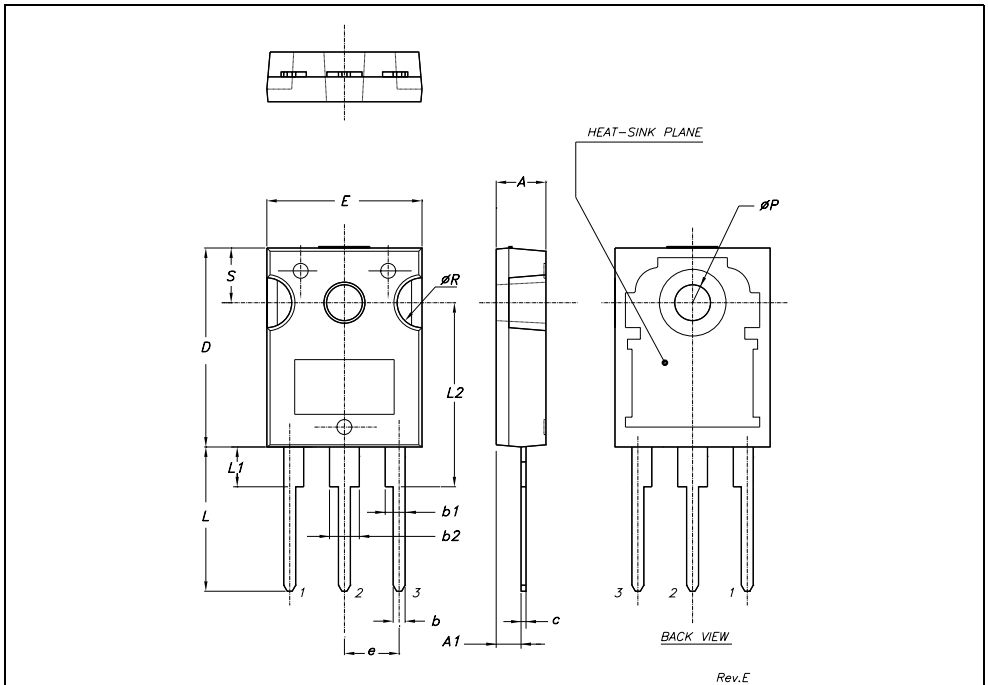


**Figure 20: Gate Charge Test Circuit**



TO-247 MECHANICAL DATA

DIM.	mm.			inch		
	MIN.	TYP	MAX.	MIN.	TYP.	MAX.
A	4.85		5.15	0.19		0.20
A1	2.20		2.60	0.086		0.102
b	1.0		1.40	0.039		0.055
b1	2.0		2.40	0.079		0.094
b2	3.0		3.40	0.118		0.134
c	0.40		0.80	0.015		0.03
D	19.85		20.15	0.781		0.793
E	15.45		15.75	0.608		0.620
e		5.45			0.214	
L	14.20		14.80	0.560		0.582
L1	3.70		4.30	0.14		0.17
L2		18.50			0.728	
øP	3.55		3.65	0.140		0.143
øR	4.50		5.50	0.177		0.216
S		5.50			0.216	



Rev.E

**Table 10: Revision History**

Date	Revision	Description of Changes
19-Oct-2004	1	First Release.

Information furnished is believed to be accurate and reliable. However, STMicroelectronics assumes no responsibility for the consequences of use of such information nor for any infringement of patents or other rights of third parties which may result from its use. No license is granted by implication or otherwise under any patent or patent rights of STMicroelectronics. Specifications mentioned in this publication are subject to change without notice. This publication supersedes and replaces all information previously supplied. STMicroelectronics products are not authorized for use as critical components in life support devices or systems without express written approval of STMicroelectronics.

The ST logo is a registered trademark of STMicroelectronics

All other names are the property of their respective owners

© 2004 STMicroelectronics - All Rights Reserved

STMicroelectronics group of companies

Australia - Belgium - Brazil - Canada - China - Czech Republic - Finland - France - Germany - Hong Kong - India - Israel - Italy - Japan - Malaysia - Malta - Morocco - Singapore - Spain - Sweden - Switzerland - United Kingdom - United States of America

[www.st.com](http://www.st.com)