



T405Q-600B-TR & T405Q-600H

Sensitive 4Q 4A TRIAC

MAIN FEATURES

Symbol	Value	Unit
$I_{T(RMS)}$	4	A
V_{DRM}/V_{RRM}	600	V
I_{GT}	5	mA

DESCRIPTION

The T405Q-600B-TR and the T405Q-600H 4 quadrants sensitive TRIACs are intended in general purpose applications where high surge current capability is required, such as irrigation systems. These TRIACs feature a gate current capability sensitivities of 5mA.

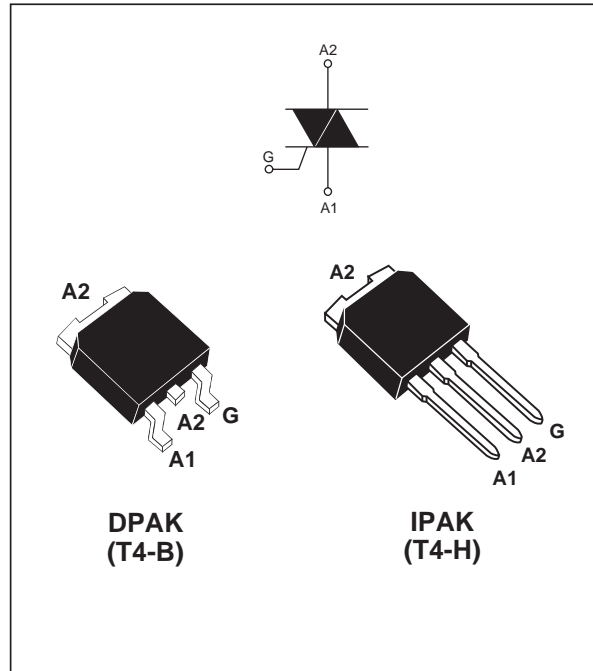

ABSOLUTE MAXIMUM RATINGS

Symbol	Parameter		Value	Unit
$I_{T(RMS)}$	RMS on-state current (Full sine wave)	DPAK / IPAK $T_c = 110^\circ\text{C}$	4	A
I_{TSM}	Non repetitive surge peak on-state current (Full cycle, T_j initial = 25°C)	F = 50Hz t = 20ms	35	A
		F = 60Hz t = 16.7ms	38	
I^2t	I^2t Value for fusing	tp = 10 ms	6	A^2s
dl/dt	Critical rate of rise of on-state current $I_G = 2 \times I_{GT}$, tr ≤ 100ns	Repetitive F = 100 Hz	50	A/μs
I_{GM}	Peak gate current	tp = 20μs $T_j = 125^\circ\text{C}$	4	A
$P_{G(AV)}$	Average gate power dissipation	$T_j = 125^\circ\text{C}$	0.5	W
T_{stg} T_j	Storage junction temperature range Operating junction temperature range		- 40 to + 150 - 40 to + 125	$^\circ\text{C}$

T405Q-600B-TR & T405Q-600H

ELECTRICAL CHARACTERISTICS (T_j = 25°C, unless otherwise specified)

Symbol	Test Conditions	Quadrant		T405Q	Unit
I _{GT} ⁽¹⁾	V _D =12V R _L =30Ω	I-II-III IV	MAX.	5 10	mA
V _{GT}		ALL	MAX.	1.3	V
V _{GD}	V _D =V _{DRM} R _L =3.3kΩ T _j = 125°C	ALL	MIN.	0.2	V
I _H ⁽²⁾	I _T = 100mA		MAX.	10	mA
I _L	I _G = 1.2I _{GT}	I - III - IV II	MAX.	10 15	mA
dV/dt ⁽²⁾	V _D =67% V _{DRM} Gate open T _j = 125°C		MIN.	10	V/μs
(dV/dt) _c ⁽²⁾	(dI/dt) _c = 1.8 A/ms T _j = 125°C		MIN.	2	V/μs

STATIC CHARACTERISTICS

Symbol	Test Conditions			Value	Unit
V _{TM} ⁽²⁾	I _{TM} = 5 A tp = 380μs	T _j = 25°C	MAX.	1.5	V
V _{TO} ⁽²⁾	Threshold voltage	T _j = 125°C	MAX.	0.85	V
R _d ⁽²⁾	Dynamic resistance	T _j = 125°C	MAX.	100	mΩ
I _{DRM} I _{RRM}	V _{DRM} = V _{RRM}	T _j = 25°C T _j = 125°C	MAX	5 1	μA mA

Note 1: Minimum I_{GT} is guaranteed at 5% of I_{GT} max.

Note 2: For both polarities of A2 referenced to A1.

THERMAL RESISTANCES

Symbol	Parameter			Value	Unit
R _{th(j-c)}	Junction to case (AC)			3	°C/W
R _{th(j-a)}	Junction to ambient	S = 0.5 cm ²	DPAK	70	°C/W
			IPAK	100	

PRODUCT SELECTOR

Part Number	Voltage	Sensitivity	Type	Package
T405Q-600B-TR	600V	5 mA	Sensitive	DPAK
T405Q-600H	600V	5 mA	Sensitive	IPAK

ORDERING INFORMATION

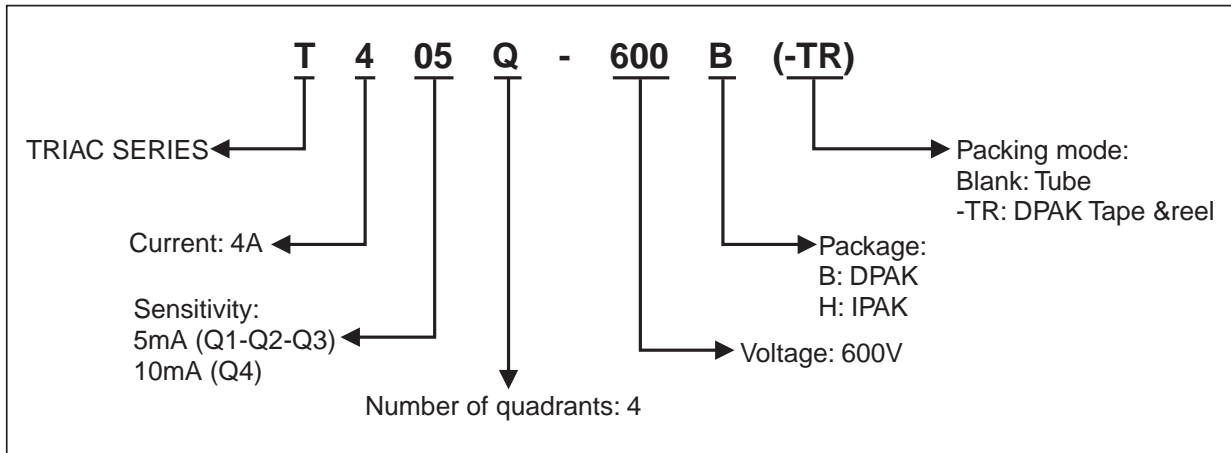

OTHER INFORMATION

Part Number	Marking	Weight	Base quantity	Packing mode
T405Q-600B-TR	T405Q600	0.3 g	2500	Tape & reel
T405Q-600H	T405Q600	0.4 g	75	Tube

T405Q-600B-TR & T405Q-600H

Fig. 1: Maximum power dissipation versus RMS on-state current.

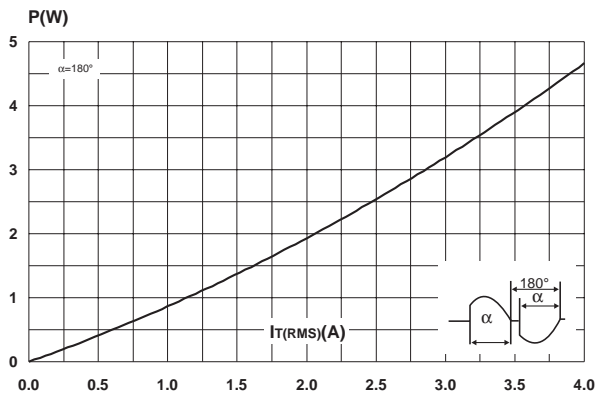

Fig. 2: RMS on-state current versus case temperature.

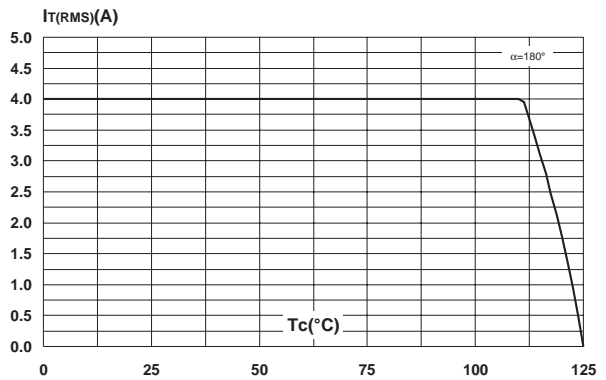

Fig. 3: Relative variation of thermal impedance versus pulse duration.

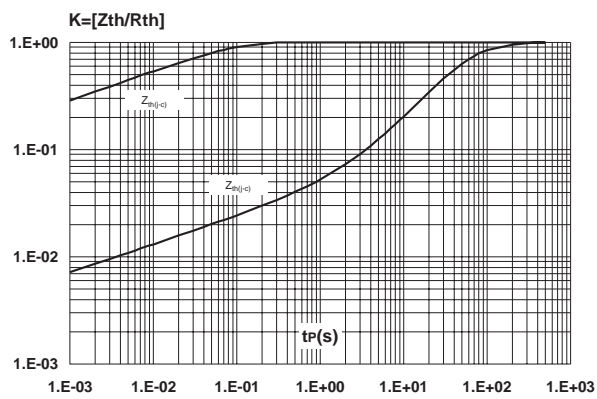

Fig. 4: On-state characteristics (maximum values).

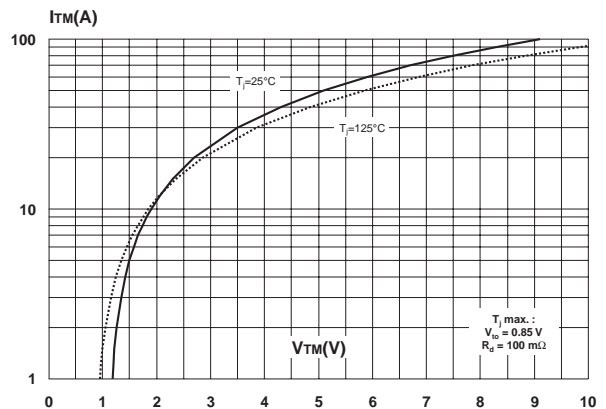

Fig. 5: Surge peak on-state current versus number of cycles.

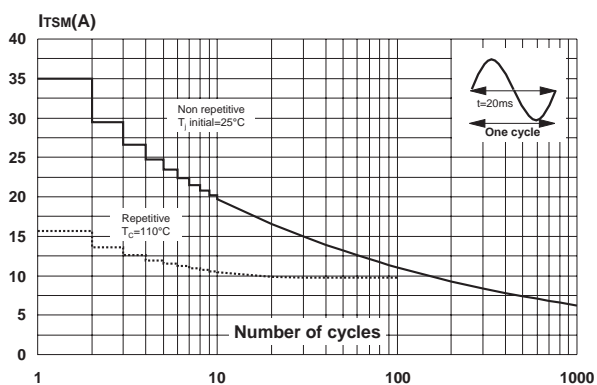

Fig. 6: Non repetitive surge peak on-state current for a sinusoidal pulse with width $t_p < 10\text{ms}$, and corresponding value of I^2t .

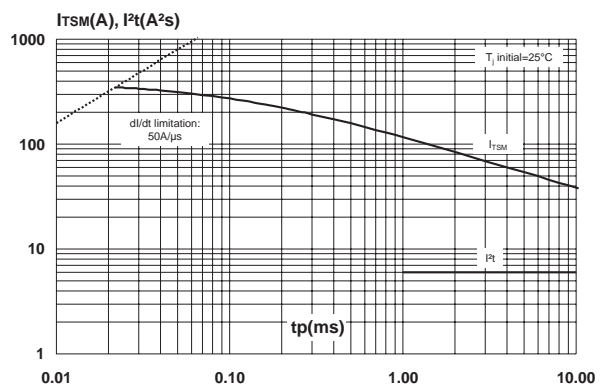

Fig. 7: Relative variation of gate trigger current, holding current and latching current versus junction temperature (typical values).

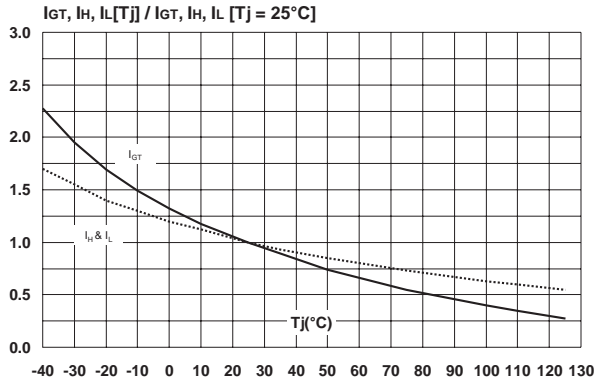

Fig. 8: Relative variation of critical rate of decrease of main current versus reapplied dV/dt (typical values).

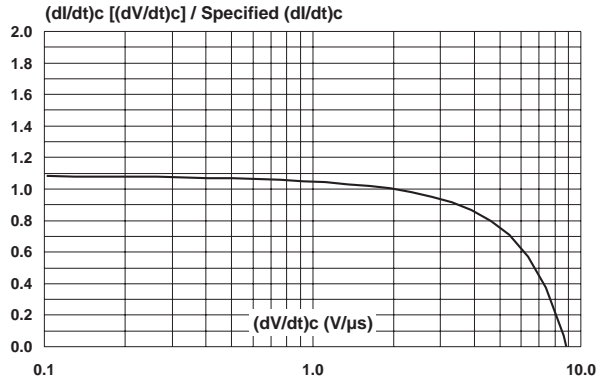

Fig. 9: Relative variation of critical rate of decrease of main current versus junction temperature.

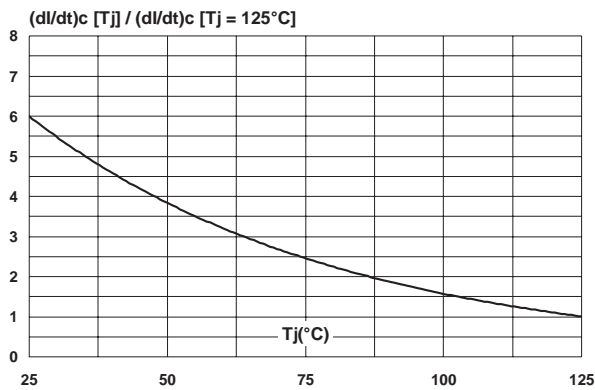

Fig. 10: Relative variation of static dV/dt immunity versus junction temperature.

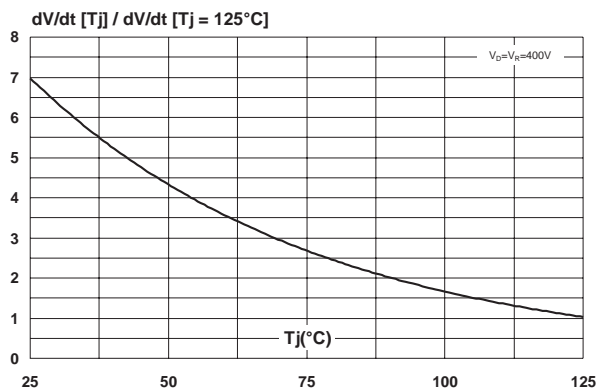
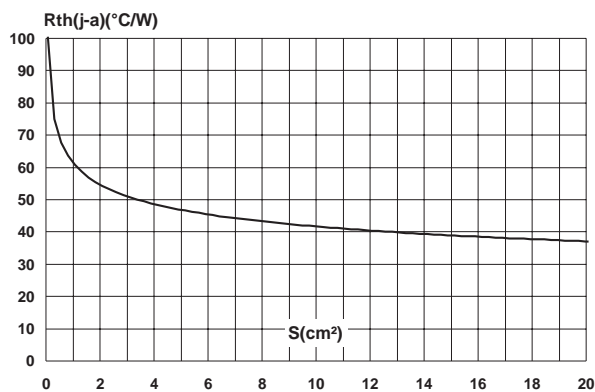
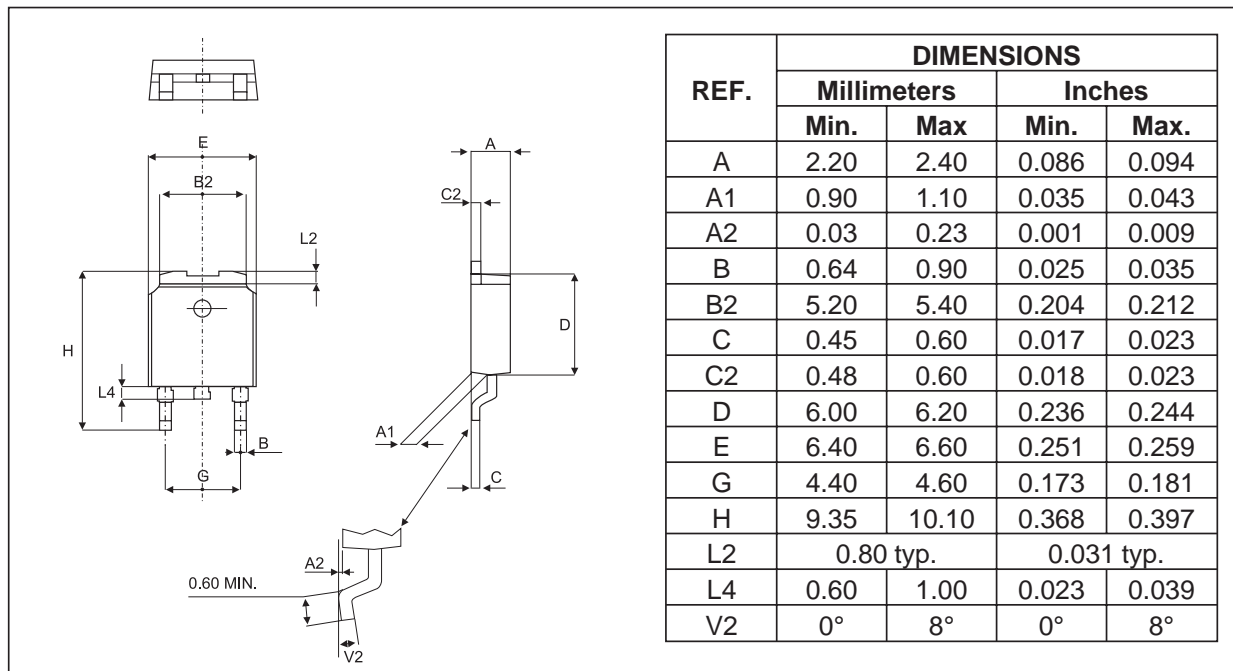

Fig. 11: Thermal resistance junction to ambient versus copper surface under tab (epoxy printed circuit board FR4, Cu = 35μm).



T405Q-600B-TR & T405Q-600H

PACKAGE MECHANICAL DATA DPAK



FOOTPRINT

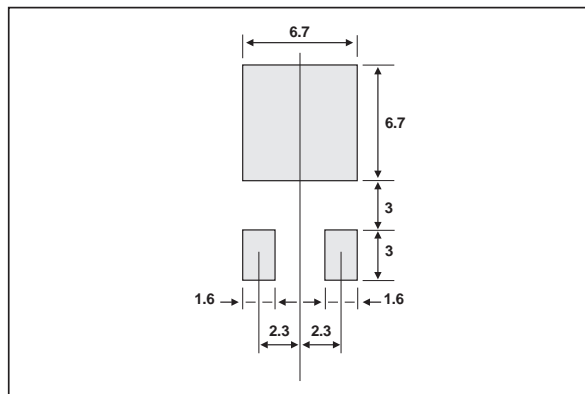

PACKAGE MECHANICAL DATA
IPAK

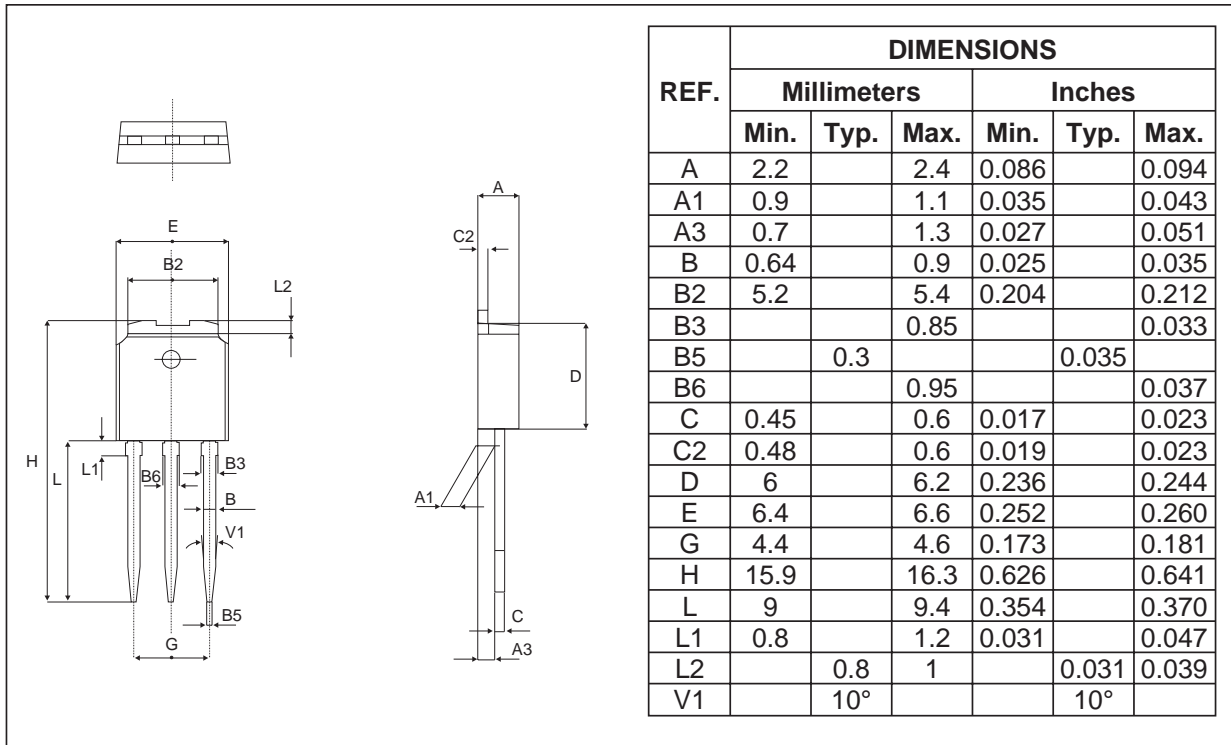

Information furnished is believed to be accurate and reliable. However, STMicroelectronics assumes no responsibility for the consequences of use of such information nor for any infringement of patents or other rights of third parties which may result from its use. No license is granted by implication or otherwise under any patent or patent rights of STMicroelectronics. Specifications mentioned in this publication are subject to change without notice. This publication supersedes and replaces all information previously supplied. STMicroelectronics products are not authorized for use as critical components in life support devices or systems without express written approval of STMicroelectronics.

The ST logo is a registered trademark of STMicroelectronics
 © 2002 STMicroelectronics - Printed in Italy - All rights reserved.
 STMicroelectronics GROUP OF COMPANIES
 Australia - Brazil - Canada - China - Finland - France - Germany
 Hong Kong - India - Israel - Italy - Japan - Malaysia - Malta - Morocco - Singapore
 Spain - Sweden - Switzerland - United Kingdom - United States.

<http://www.st.com>

