



# TSH110-111-112-113-114

## WIDE BAND, LOW NOISE OPERATIONAL AMPLIFIERS

- **LOW NOISE:** 3nV/√Hz
- **LOW SUPPLY CURRENT:** 3.2mA
- **47mA OUTPUT CURRENT**
- **BANDWIDTH:** 100MHz
- **5V to 12V SUPPLY VOLTAGE**
- **SLEW-RATE:** 450V/μs
- **SPECIFIED FOR 100Ω Load**
- **VERY LOW DISTORTION**
- **TINY: SOT23-5, TSSOP and SO PACKAGES**

### DESCRIPTION

The singles TSH110 and TSH111, the dual TSH112, the triple TSH113 and the quad TSH114 are current feedback operational amplifiers featuring a very high slew rate of 450V/μs and a large bandwidth of 100MHz, with only a 3.2mA quiescent supply current. The TSH111 and TSH113 feature a Standby function for each operator. This function is a power down mode with a high output impedance.

These devices operate from ±2.5V to ±6V dual supply voltage or from 5V to 12V single supply voltage. They are able to drive a 100Ω load with a swing of 9V minimum (for a 12V power supply).

The harmonic and intermodulation distortions of these devices are very low, making this circuit a good choice for applications requiring wide bandwidth with multiple carriers.

For board space and weight saving, the TSH110 comes in miniature SOT23-5 package, the TSH111 comes in SO8 and TSSOP8 packages, the TSH112 comes in SO8 and TSSOP8 packages, the TSH113 and TSH114 comes in SO14 and TSSOP14 packages.

### APPLICATIONS

- High End Video Drivers
- Receiver for xDSL
- A/D Converter Driver
- High End Audio Applications

### PIN CONNECTIONS (top view)

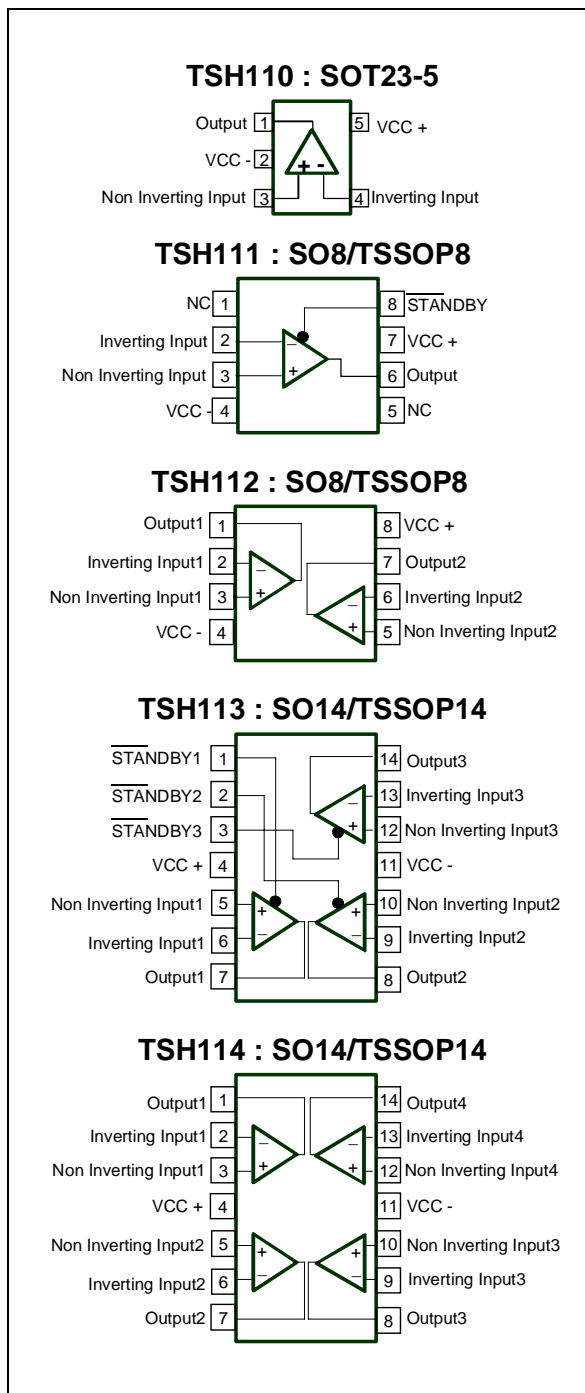

**ABSOLUTE MAXIMUM RATINGS**

Symbol	Parameter	Value	Unit
$V_{CC}$	Supply Voltage <sup>1)</sup>	14	V
$V_{id}$	Differential Input Voltage <sup>2)</sup>	±1	V
$V_i$	Input Voltage <sup>3)</sup>	±6	V
$T_{oper}$	Operating Free Air Temperature Range	-40 to +85	°C
$T_{stg}$	Storage Temperature	-65 to +150	°C
$T_j$	Maximum Junction Temperature	150	°C
$R_{thjc}$	Thermal resistance junction to case		°C/W
	SOT23-5	80	
	SO8	28	
	SO14	22	
	TSSOP8	37	
	TSSOP14	32	
$R_{thja}$	Thermal resistance junction to ambiente area		°C/W
	SOT23-5	250	
	SO8	157	
	SO14	125	
	TSSOP8	130	
	TSSOP14	110	
ESD	Human Body Model	2.0	kV
	Machine Model	0.2	
	Charged Device Model	1.5	
	output short circuit duration <sup>4)</sup>		

1. All voltages values, except differential voltage are with respect to network ground terminal
2. Differential voltages are non-inverting input terminal with respect to the inverting terminal
3. The magnitude of input and output must never exceed  $V_{CC} + 0.3V$
4. Short-circuits can cause excessive heating. Destructive dissipation can result.

**OPERATING CONDITIONS**

Symbol	Parameter	Value	Unit
$V_{CC}$	Supply Voltage	5 to 12	V
$V_{icm}$	Common Mode Input Voltage Range	$V_{CC} + 1.5$ to $V_{CC} - 1.5$	V

**ORDER CODES**

Type	Temperature	Package
TSH110ILT (code K302)	-40° to +85°C	SOT23-5
TSH111ID		SO8
TSH111IDT		SO8
TSH111IPT		TSSOP8
TSH112ID		SO8
TSH112IDT		SO8
TSH112IPT		TSSOP8
TSH113ID		SO14
TSH113IDT		SO14
TSH113IPT		TSSOP14
TSH114ID		SO14
TSH114IDT		SO14
TSH114IPT		TSSOP14

D = Small Outline Package (SO) - also available in Tape & Reel (DT)  
P = Thin Shrink Small Outline Package (TSSOP) - only available in Tape & Reel (PT)  
L = Tiny Package (SOT23-5) - only available in Tape & Reel (LT)



**ELECTRICAL CHARACTERISTICS** (pages 3 and 4)Dual Supply Voltage,  $V_{CC} = \pm 2.5$ Volts,  $R_{fb}^* = 680\Omega$ ,  $T_{amb} = 25^\circ\text{C}$  (unless otherwise specified)

Symbol	Parameter	Test Condition	Min.	Typ.	Max.	Unit	
<b>DC PERFORMANCE</b>							
$V_{io}$	Input Offset Voltage	$T_{amb}$	-1.5	0.3	2.0	mV	
		$T_{min.} < T_{amb} < T_{max.}$		1		mV	
$\Delta V_{io}$	Input Offset Voltage Drift vs. Temperature	$T_{min.} < T_{amb} < T_{max.}$		5		$\mu\text{V}/^\circ\text{C}$	
$I_{ib+}$	Non Inverting Input Bias Current	$T_{amb}$	-10	1.4	13	$\mu\text{A}$	
		$T_{min.} < T_{amb} < T_{max.}$		2.5		$\mu\text{A}$	
$I_{ib-}$	Inverting Input Bias Current	$T_{amb}$	-3	1.9	7	$\mu\text{A}$	
		$T_{min.} < T_{amb} < T_{max.}$		2.5		$\mu\text{A}$	
$R_{OL}$	Transimpedance	$R_L = 100\Omega$	500	750		k $\Omega$	
$I_{CC}$	Supply Current per Operator	$T_{amb}$		3.2	4	mA	
		$T_{min.} < T_{amb} < T_{max.}$		3.5		mA	
CMR	Common Mode Rejection Ratio ( $\Delta V_{ic}/\Delta V_{io}$ )		56	60		dB	
SVR	Supply Voltage Rejection Ratio ( $\Delta V_{CC}/\Delta V_{io}$ )		70	80		dB	
PSR	Power Supply Rejection Ratio ( $\Delta V_{CC}/\Delta V_{out}$ )	Gain=1, $R_{load}=3.9\text{k}\Omega$		48		dB	
<b>DYNAMIC PERFORMANCE and OUTPUT CHARACTERISTICS</b>							
$V_{oh}$	High Level Output Voltage	$T_{amb}$ $R_L = 100\Omega$	1.4	2		V	
		$T_{min.} < T_{amb} < T_{max.}$ $R_L = 100\Omega$ GND		1.9		V	
$V_{ol}$	Low Level Output Voltage	$T_{amb}$ $R_L = 100\Omega$		-1.8	-1.3	V	
		$T_{min.} < T_{amb} < T_{max.}$ $R_L = 100\Omega$		-1.7		V	
$ I_{sink} $	Output Sink current	$T_{min.} < T_{amb} < T_{max.}$		20		mA	
$I_{source}$	Output Source current	$T_{min.} < T_{amb} < T_{max.}$		18		mA	
BW	-3dB Bandwidth	$V_{out}=1\text{Vpk}$ , $R_{fb}^*=820\Omega//2\text{pF}$ Load=100 $\Omega$ $A_{VCL}=+2$		81		MHz	
SR	Slew Rate	$A_{VCL}=+2$ , 2V step Load=100 $\Omega$	160	230		V/ $\mu\text{s}$	
$T_r$	Rise Time	for 200mV step $A_{VCL}=+2$ , $R_{fb}^*=820\Omega//2\text{pF}$ Load=100 $\Omega$		9		ns	
$T_f$	Fall Time			9		ns	
Ov	Overshoot				16		%
St	Settling Time @ 0.05%				60		ns
$\Delta G$	Differential gain	$A_{VCL}=+2$ , $R_L=100\Omega$		0.05		%	
$\Delta\phi$	Differential phase	$F=4.5\text{MHz}$ , $V_{out}=1\text{Vpeak}$		0.05		$^\circ$	

**TSH110-TSH111-TSH112-TSH113-TSH114**

Symbol	Parameter	Test Condition	Min.	Typ.	Max.	Unit
<b>NOISE AND HARMONIC PERFORMANCE</b>						
en	Equivalent Input Voltage Noise	Frequency : 1MHz		3		nV/ $\sqrt{\text{Hz}}$
in	Equivalent Input Current Noise			8.5		pA/ $\sqrt{\text{Hz}}$
THD	Total Harmonic Distortion	$A_{VCL}=+2$ , $F=2\text{MHz}$ $R_L=100\Omega$ $V_{out}=2V_{peak}$		64.4		dB
IM3	Third order inter modulation product	$A_{VCL}=+2$ , $V_{out}=2V_{pp}$ $R_L=100\Omega$ $F1=1\text{MHz}$ , $F2=1.1\text{MHz}$				dBc
		@900kHz		90		
		@1.2MHz		90		
		@3.1MHz		86		
		@3.2MHz		83		
<b>MATCHING CHARACTERISTICS</b>						
Gf	Gain Flatness	$F=(\text{DC})$ to 6MHz $A_{VCL}=+2$ , $V_{out}=2V_{pp}$		0.1		dB
Vo1/Vo2	Channel Separation	$F=1\text{MHz}$ to 10MHz		65		dB

(\*)  $R_{fb}$  is the feedback resistance between the output and the inverting input of the amplifier.

**ELECTRICAL CHARACTERISTICS** (pages 5 and 6)Dual Supply Voltage,  $V_{CC}=\pm 6\text{Volts}$ ,  $R_{fb}^* = 680\Omega$ ,  $T_{amb} = 25^\circ\text{C}$  (unless otherwise specified)

Symbol	Parameter	TestCondition	Min.	Typ.	Max.	Unit
<b>DC PERFORMANCE</b>						
$V_{io}$	Input Offset Voltage	$T_{amb}$	-1.0	0.9	3.0	mV
		$T_{min.} < T_{amb} < T_{max.}$		1.3		mV
$\Delta V_{io}$	Input Offset Voltage Drift vs Temperature	$T_{min.} < T_{amb} < T_{max.}$		5		$\mu\text{V}/^\circ\text{C}$
$I_{ib+}$	Non Inverting Input Bias Current	$T_{amb}$	-12	1	14	$\mu\text{A}$
		$T_{min.} < T_{amb} < T_{max.}$		1.7		$\mu\text{A}$
$I_{ib-}$	Inverting Input Bias Current	$T_{amb}$	-4	3	10	$\mu\text{A}$
		$T_{min.} < T_{amb} < T_{max.}$		3.4		$\mu\text{A}$
$R_{OL}$	Transimpedance	$R_L = 100\Omega$	600	900		k $\Omega$
$I_{CC}$	Supply Current per Operator	$T_{amb}$		4	5	mA
		$T_{min.} < T_{amb} < T_{max.}$		4.1		mA
CMR	Common Mode Rejection Ratio ( $\Delta V_{ic}/\Delta V_{io}$ )		58	63		dB
SVR	Supply Voltage Rejection Ratio ( $\Delta V_{cc}/\Delta V_{io}$ )		72	80		dB
PSR	Power Supply Rejection Ratio ( $\Delta V_{cc}/\Delta V_{out}$ )	Gain=1, $R_{load}=3.9\text{k}\Omega$		49		dB
<b>DYNAMIC PERFORMANCE and OUTPUT CHARACTERISTICS</b>						
$V_{oh}$	High Level Output Voltage	$T_{amb}$ $R_L = 100\Omega$	4.5	4.7		V
		$T_{min.} < T_{amb} < T_{max.}$ $R_L = 100\Omega$		4.6		V
$V_{ol}$	Low Level Output Voltage	$T_{amb}$ $R_L = 100\Omega$		-4.7	-4.3	V
		$T_{min.} < T_{amb} < T_{max.}$ $R_L = 100\Omega$		-4.6		V
$ I_{sink} $	Output Sink current	$T_{min.} < T_{amb} < T_{max.}$		47		mA
$I_{source}$	Output Source current	$T_{min.} < T_{amb} < T_{max.}$		46		mA
Bw	-3dB Bandwidth	$V_{out}=1\text{Vpk}$ , $R_{fb}^*=680\Omega//2\text{pF}$ Load=100 $\Omega$ $A_{VCL}=+2$		100		MHz
SR	Slew Rate	$A_{VCL}=+2$ , 6V step Load=100 $\Omega$	240	450		V/ $\mu\text{s}$
Tr	Rise Time	for 200mV step $A_{VCL}=+2$ , $R_{fb}^*=680\Omega//2\text{pF}$ Load=100 $\Omega$		10.4		ns
Tf	Fall Time			12.2		ns
Ov	Overshoot			17		%
St	Settling Time @ 0.05%			40		ns
$\Delta G$	Differential gain		$A_{VCL}=+2$ , $R_L=100\Omega$		0.05	
$\Delta\phi$	Differential phase	$F=4.5\text{MHz}$ , $V_{out}=2\text{Vpeak}$		0.05		$^\circ$

**TSH110-TSH111-TSH112-TSH113-TSH114**

Symbol	Parameter	TestCondition	Min.	Typ.	Max.	Unit
<b>NOISE AND HARMONIC PERFORMANCE</b>						
en	Equivalent Input Voltage Noise	Frequency : 1MHz		3		nV/ $\sqrt{\text{Hz}}$
in	Equivalent Input Current Noise			8.6		pA/ $\sqrt{\text{Hz}}$
THD	Total Harmonic Distortion	$A_{VCL}=+2$ , $F=2\text{MHz}$ $R_L=100\Omega$ $V_{out}=4V_{pp}$		67.7		dB
IM3	Third order inter modulation product	$A_{VCL}=+2$ , $V_{out}=4V_{pp}$ $R_L=100\Omega$ $F1=1\text{MHz}$ , $F2=1.1\text{MHz}$				dBc
		@900kHz		82		
		@1.2MHz		84		
		@3.1MHz		77		
		@3.2MHz		73		
<b>MATCHING CHARACTERISTICS</b>						
Gf	Gain Flatness	$F=(\text{DC})$ to 6MHz $A_{VCL}=+2$ , $V_{out}=4V_{pp}$		0.1		dB
Vo1/Vo2	Channel Separation	$F=1\text{MHz}$ to 10MHz		65		dB

(\*)  $R_{fb}$  is the feedback resistance between the output and the inverting input of the amplifier.

**STANDBY MODE**T<sub>amb</sub> = 25°C (unless otherwise specified), V<sub>CC</sub> = ±6Volts

Symbol	Parameter	Test Condition	Min.	Typ.	Max.	Unit
V <sub>low</sub>	Standby Low Level		V <sub>CC</sub> <sup>-</sup>		(V <sub>CC</sub> <sup>-</sup> +0.8)	V
V <sub>high</sub>	Standby High Level		(V <sub>CC</sub> <sup>-</sup> +2)		(V <sub>CC</sub> <sup>+</sup> )	V
I <sub>CC SBY</sub>	Current Consumption per Operator in Standby mode			26	40	μA
I <sub>sol</sub>	Input/Output Isolation	F=1MHz		-90		dB
Z <sub>out</sub>	Output Impedance (R <sub>out</sub> // C <sub>out</sub> )	R <sub>out</sub> C <sub>out</sub>		31 25		MΩ pF
T <sub>on</sub>	Time from Standby Mode to Active Mode			2		μs
T <sub>off</sub>	Time from Active Mode to Standby Mode	Down to I <sub>CC SBY</sub> = 40μA		13		μs

TSH111 STANDBY CONTROL pin 8 ( $\overline{\text{SBY}}$ )	OPERATOR STATUS
V <sub>low</sub>	Standby
V <sub>high</sub>	Active

TSH113 STANDBY CONTROL			OPERATOR STATUS		
pin 1 ( $\overline{\text{SBY}}$ OP1)	pin 2 ( $\overline{\text{SBY}}$ OP2)	pin 3 ( $\overline{\text{SBY}}$ OP)	OP1	OP1	OP3
V <sub>low</sub>	x	x	Standby	x	x
V <sub>high</sub>	x	x	Active	x	x
x	V <sub>low</sub>	x	x	Standby	x
x	V <sub>high</sub>		x	Active	x
x	x	V <sub>low</sub>	x	x	Standby
x	x	V <sub>high</sub>	x	x	Active

**(fig.1) Closed Loop Gain vs. Frequency**

$A_V=+1$ ,  $R_{fb}=2.2k\Omega$ ,  $C_{fb}=2pF$ ,  $R_L=100\Omega$ ,  $V_{in}=100mVp$

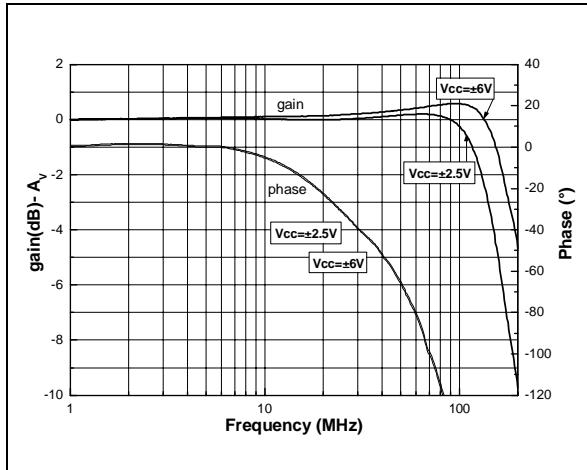

**(fig.2) Closed Loop Gain vs. Frequency**

$A_V=-1$ ,  $R_{fb}=2.2k\Omega$ ,  $C_{fb}=2pF$ ,  $R_L=100\Omega$ ,  $V_{in}=100mVp$

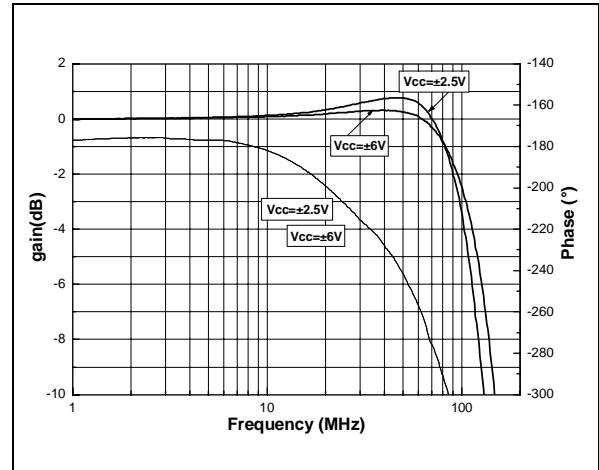

**(fig.3) Closed Loop Gain vs. Frequency**

$A_V=+2$ ,  $R_{fb}=680\Omega$ ,  $C_{fb}=2pF$ ,  $R_L=100\Omega$ ,  $V_{in}=100mVp$

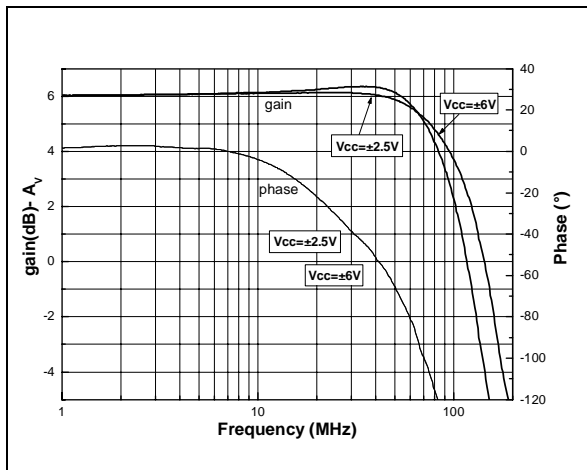

**(fig.4) Closed Loop Gain vs. Frequency**

$A_V=-2$ ,  $R_{fb}=680k\Omega$ ,  $C_{fb}=2pF$ ,  $R_L=100\Omega$ ,  $V_{in}=100mVp$

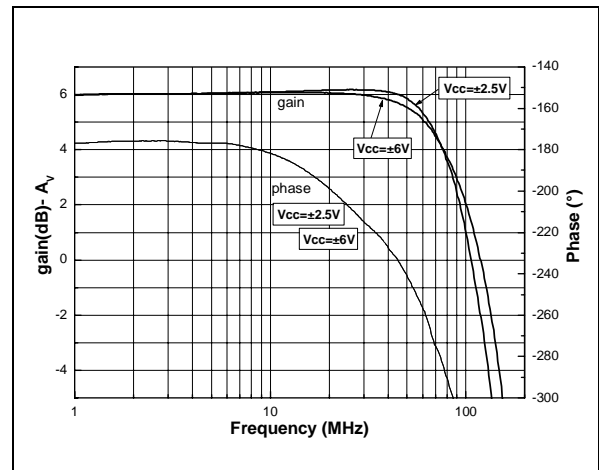

**(fig.5) Closed Loop Gain vs. Frequency**

$A_V=+10$ ,  $R_{fb}=510\Omega$ ,  $R_L=100\Omega$ ,  $V_{in}=30mVp$

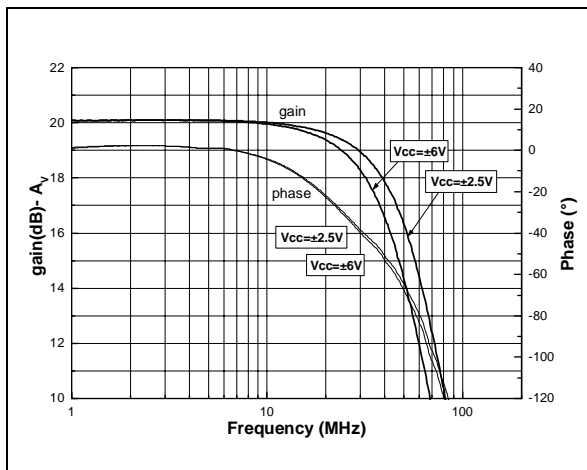

**(fig.6) Closed Loop Gain vs. Frequency**

$A_V=-10$ ,  $R_{fb}=510\Omega$ ,  $R_L=100\Omega$ ,  $V_{in}=30mVp$

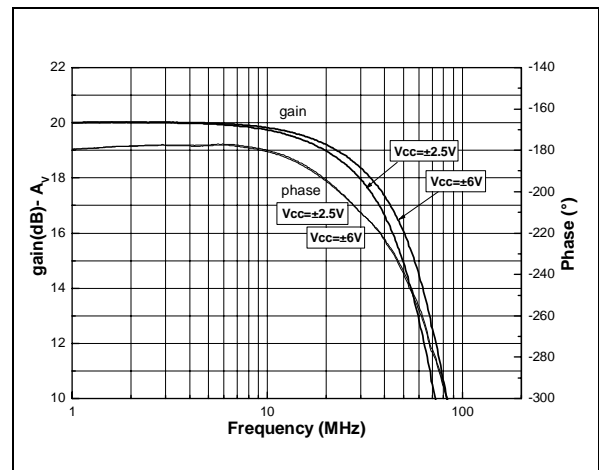



**(fig.7): Positive Slew Rate**

$A_V=+2$ ,  $R_{fb}=680\Omega$ ,  $C_{fb}=2pF$ ,  $R_L=100\Omega$ ,  $V_{cc}=\pm 6V$

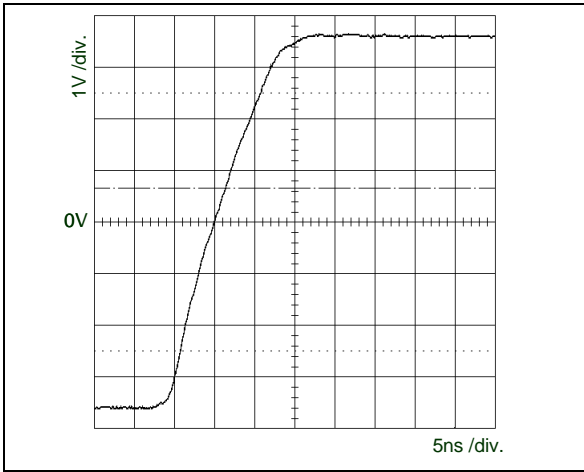

**(fig.8): Negative Slew Rate**

$A_V=+2$ ,  $R_{fb}=680\Omega$ ,  $C_{fb}=2pF$ ,  $R_L=100\Omega$ ,  $V_{cc}=\pm 6V$

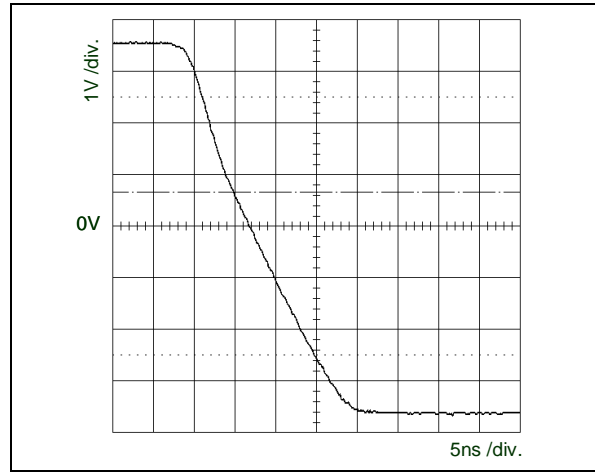

**(fig.9): Positive Slew Rate**

$A_V=+2$ ,  $R_{fb}=680\Omega$ ,  $C_{fb}=2pF$ ,  $R_L=100\Omega$ ,  $V_{cc}=\pm 2.5V$

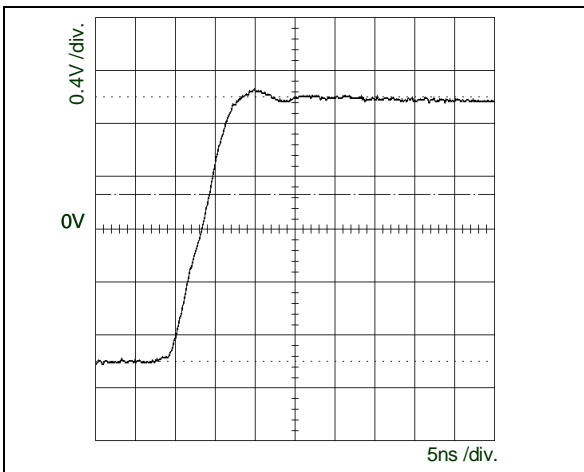

**(fig.10): Negative Slew Rate**

$A_V=+2$ ,  $R_{fb}=680\Omega$ ,  $C_{fb}=2pF$ ,  $R_L=100\Omega$ ,  $V_{cc}=\pm 2.5V$

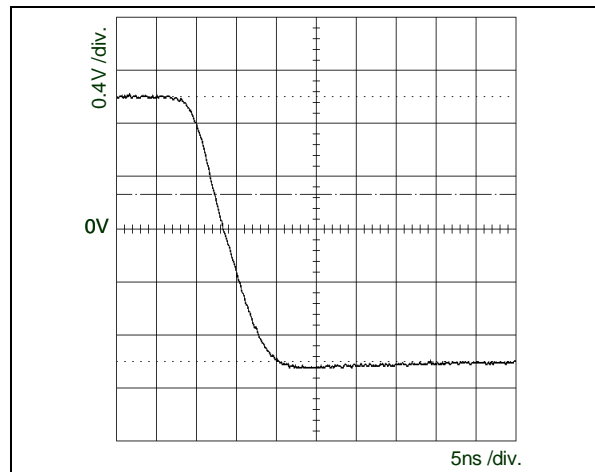

**(fig.11): Input Voltage Noise Level**

$A_V=+100$ ,  $R_{fb}=1k\Omega$ , Input+ connected to Gnd via 10 $\Omega$

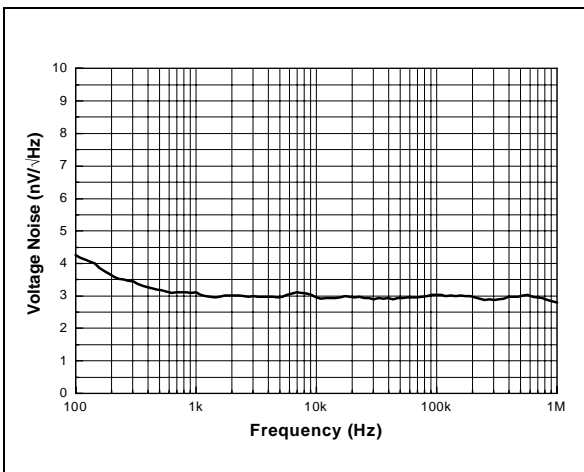

**(fig.12):  $V_{io}$  vs. Power Supply**

Open loop, no load

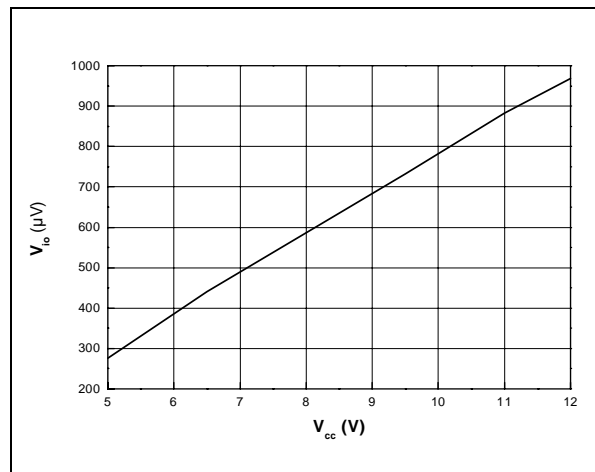

**(fig.13):  $I_{cc(-)}$  vs. Power Supply**  
Open loop, no load

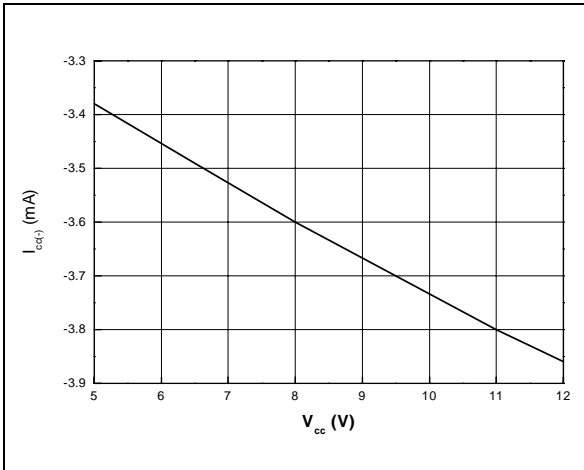

**(fig.14):  $I_{cc(+)}$  vs. Power Supply**  
Open loop, no load

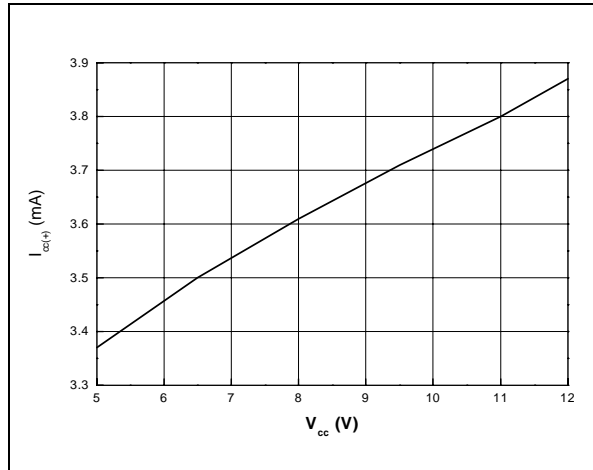

**(fig.15):  $I_{ib(-)}$  vs. Power Supply**  
Open loop, no load

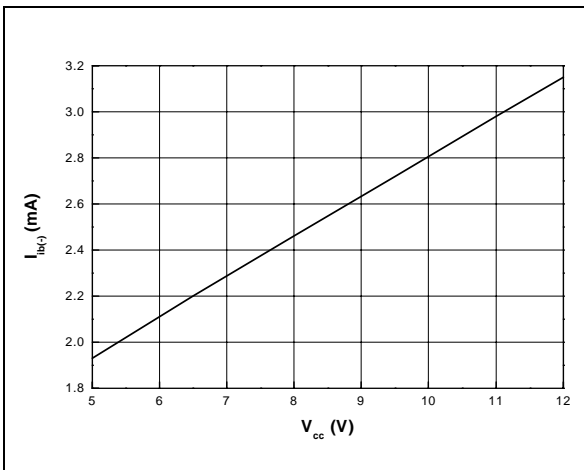

**(fig.16):  $I_{ib(+)}$  vs. Power Supply**  
Open loop, no load

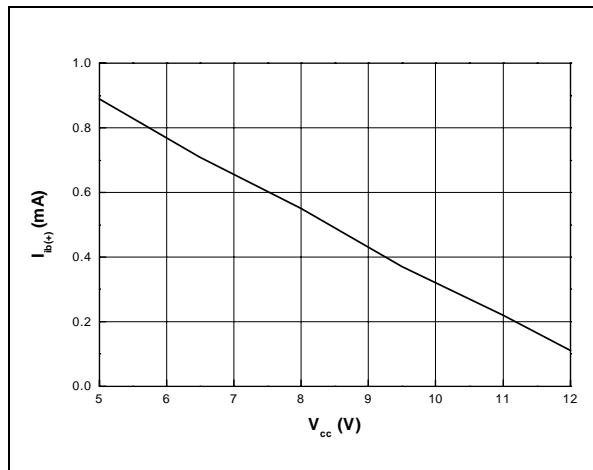

**(fig.17):  $V_{ol}$  vs. Power Supply**  
Open loop,  $R_L=100\Omega$

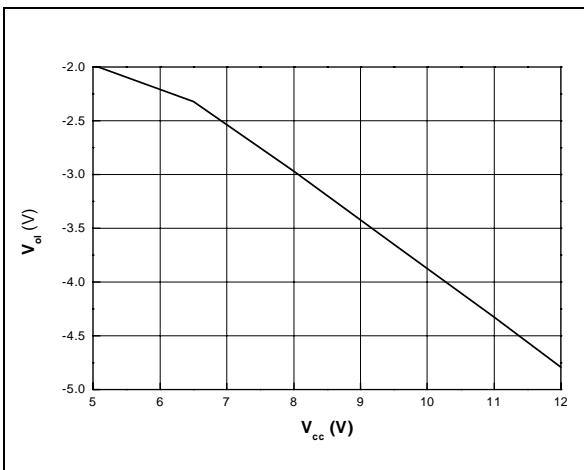

**(fig.18):  $V_{oh}$  vs. Power Supply**  
Open loop,  $R_L=100\Omega$

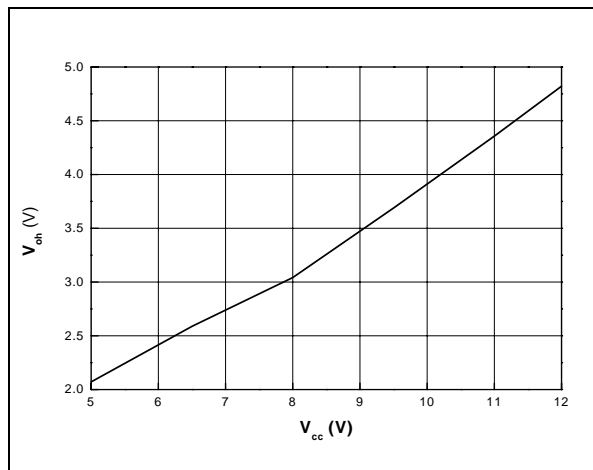

**(fig.19):  $I_{cc}$  vs. Temperature**

Open loop, no load

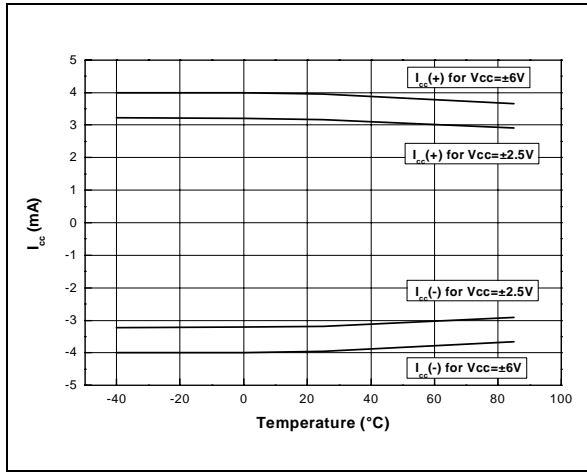

**(fig.20):  $I_{cc}$  (Standby) vs. Temperature**

Open loop, no load

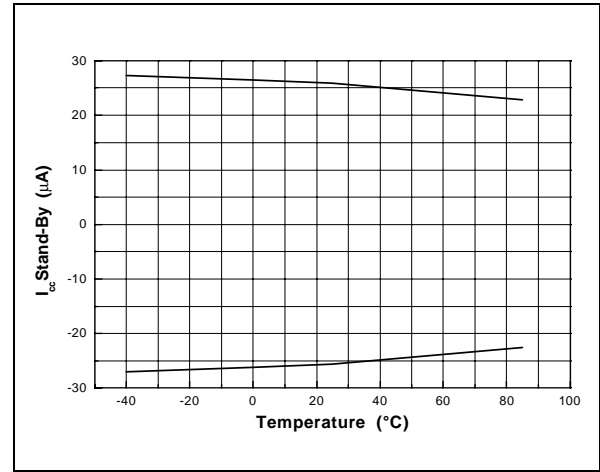

**(fig.21):  $R_{OL}$  vs. Temperature**

Open loop, no load

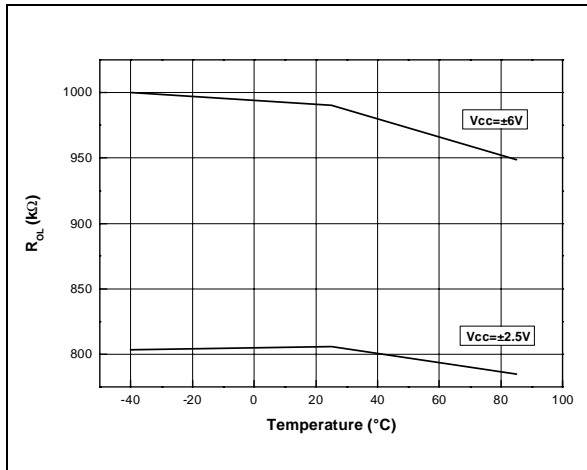

**(fig.22): CMR vs. Temperature**

Open loop, no load

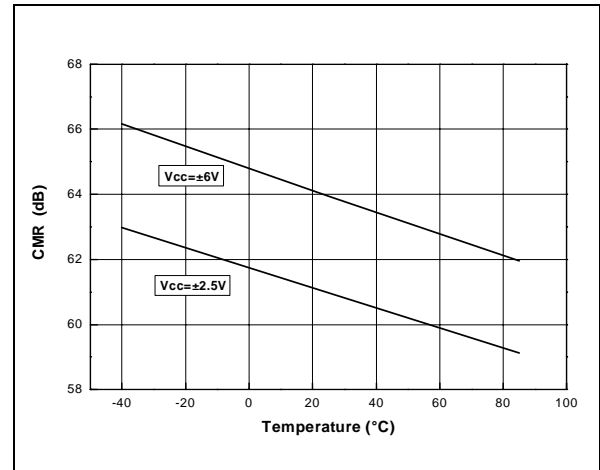

**(fig.23):  $V_{OH}$  &  $V_{OL}$  vs. Temperature**

Open loop,  $R_L=100\Omega$

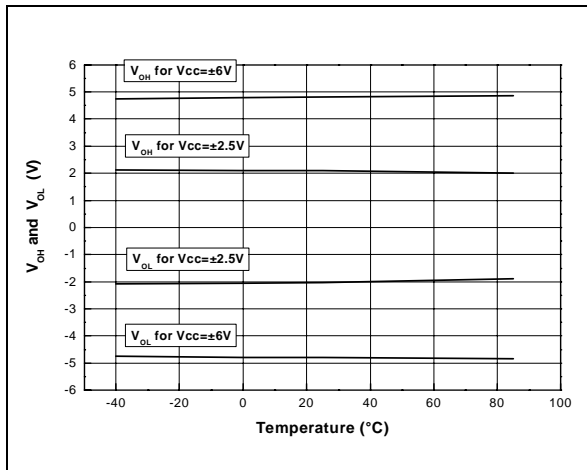

**(fig.24): Slew Rate vs. Temperature**

$A_V=+2$ ,  $R_L=100\Omega$

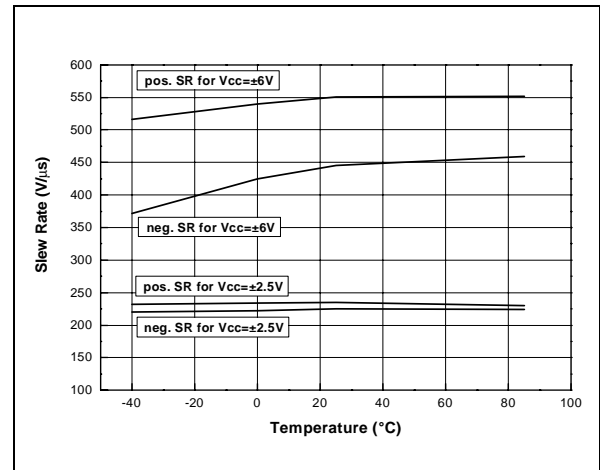

**(fig.25): Group Delay**

$A_V=+2$ ,  $R_{fb}=680\Omega$ ,  $C_{fb}=2pF$ ,  $R_L=100\Omega$

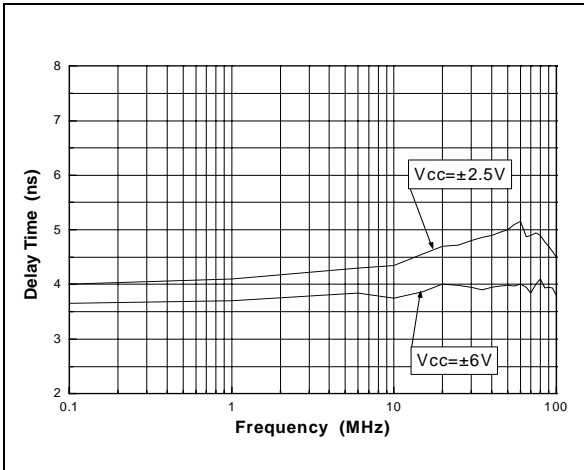

**(fig.26): Gain Flatness**

$A_V=+2$ ,  $R_{fb}=680\Omega$ ,  $C_{fb}=2pF$ ,  $R_L=100\Omega$

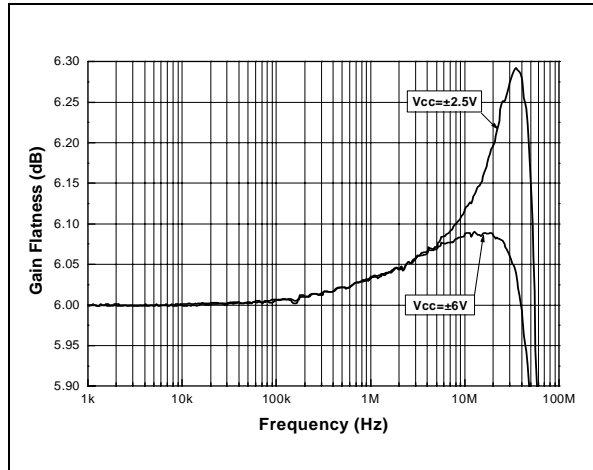

**(fig.27): Frequency Response vs. Load**

$A_V=+2$ ,  $R_{fb}=680\Omega$ ,  $C_{fb}=2pF$ ,  $V_{CC}=\pm 2.5V$ , (fig.29)

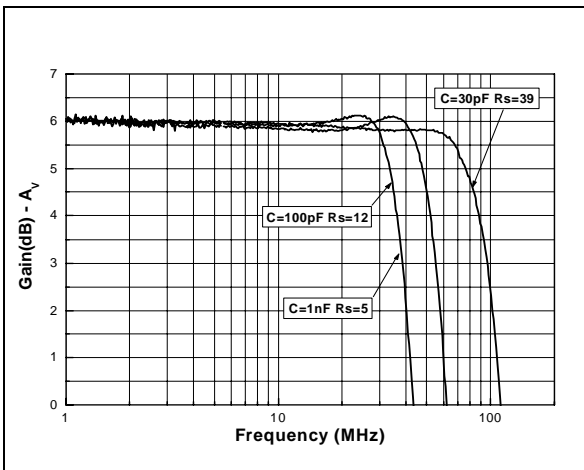

**(fig.28): Frequency Response vs. Load**

$A_V=+2$ ,  $R_{fb}=680\Omega$ ,  $C_{fb}=2pF$ ,  $V_{CC}=\pm 6V$ , (fig.29)

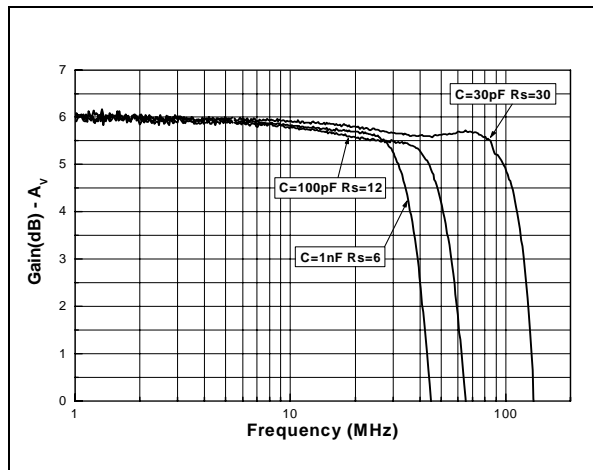

**(fig.29): Capacitive Load Schematic.**  
measurements on (fig.27) and (fig.28)

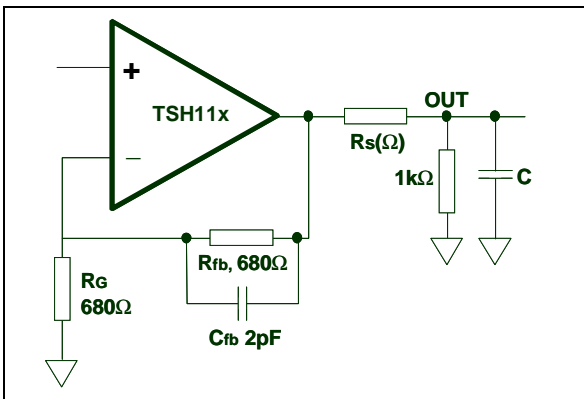

**Intermodulation Distortion**

A non-ideal output of the amplifier can be described by the following development :

$$V_{out}=C_0+C_1(V_{in})+C_2(V_{in})^2+C_3(V_{in})^3+...+C_n(V_{in})^n$$

due to a non-linearity in the input-output amplitude transfert. In the case of  $V_{in}=Asin\omega t$ ,  $C_0$  is the DC component,  $C_1(V_{in})$  is the fundamental,  $C_nA^n$  is the amplitude of the harmonics.

A one-frequency or one-tone input signal contributes to a harmonic distortion. A two-tones input signal contributes to a harmonic distortion and intermodulation product.

This intermodulation product or intermodulation distortion of a two-tones input signal is the first step of the amplifier study for driving capability in the case of a multitone signal.

In this case  $V_{in}=Asin\omega_1t+Bsin\omega_2t$ , and :

$$\begin{aligned} V_{out}= & C_0+C_1(Asin\omega_1t+Bsin\omega_2t) \\ & + \\ & C_2(Asin\omega_1t+Bsin\omega_2t)^2+C_3(Asin\omega_1t+Bsin\omega_2t)^3 \\ & + \\ & ...C_n(V_{in})^n \end{aligned}$$

$$\begin{aligned} V_{out}= & C_0+C_1(Asin\omega_1t+Bsin\omega_2t) \\ & + \\ & C_2(A^2+B^2)/2-(C_2/2)(A^2cos2\omega_1t+B^2cos2\omega_2t) \\ & + \\ & 2C_2AB(cos(\omega_1-\omega_2)t-cos(\omega_1+\omega_2)t) \\ & + \\ & (3C_3/4) \\ & (A^3sin\omega_1t+B^3sin\omega_2t+2A^2Bsin\omega_2t+2B^2Asin\omega_1t) \\ & + \\ & (C_3A^3sin3\omega_1t+B^3sin3\omega_2t) \\ & + \\ & (3C_3A^2B/2)(sin(2\omega_1-\omega_2)t-1/2sin(2\omega_1+\omega_2)t) \\ & + \\ & (3C_3B^2A/2)(sin(-\omega_1+2\omega_2)t-1/2sin(\omega_1+2\omega_2)t) \\ & + \\ & ...C_n(V_{in})^n \end{aligned}$$

In this expression, we can recognize the second order intermodulation IM2 by the frequencies  $(\omega_1-\omega_2)$  and  $(\omega_1+\omega_2)$  and the third order intermodulation IM3 by the frequencies  $(2\omega_1-\omega_2)$ ,  $(2\omega_1+\omega_2)$ ,  $(-\omega_1+2\omega_2)$  and  $(\omega_1+2\omega_2)$ .

The following graphs show the IM3 of the amplifier in two cases as a function of the output amplitude. The two-tones input signal is achieved by the multisource generator Marconi 2026. Each tone has the same amplitude. The measurement is achieved by the spectrum analyser HP 3585A. Both instruments are phase locked to enhance measurement precision.

**(fig.30): 3<sup>rd</sup> Order Intermodulation (180kHz & 280kHz)**

$A_V=+4$ ,  $R_{fb}=680\Omega$ , no  $C_{fb}$ ,  $R_L=100\Omega$ ,  $V_{cc}=\pm 6V$

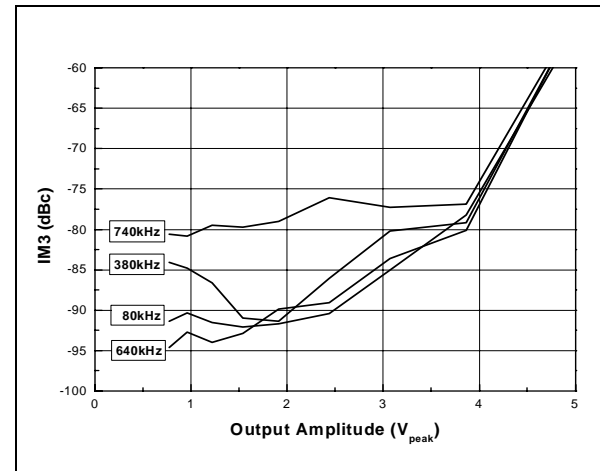

**(fig.31): 3<sup>rd</sup> Order Intermodulation (1MHz & 1.1MHz)**

$A_V=+2$ ,  $R_{fb}=680\Omega$ ,  $C_{fb}=2pF$ ,  $R_L=100\Omega$ ,  $V_{cc}=\pm 2.5V$

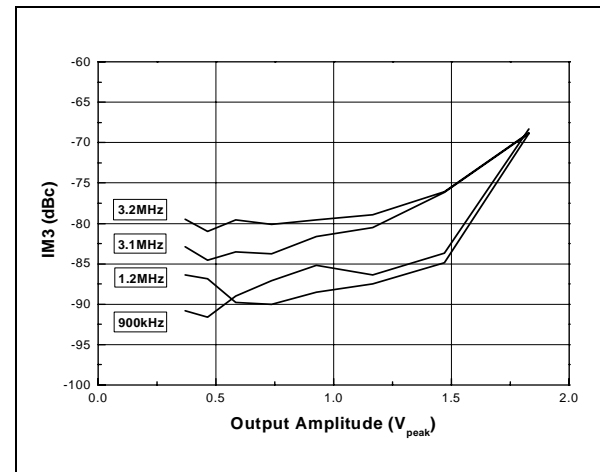

**Printed Circuit Board Layout Considerations**

In this range of frequency, printed circuit board parasitics can affect the closed-loop performance. The implementation of a proper ground plane in both sides of the PCB is mandatory to provide low inductance and low resistance common return. Most important for controlling the gain flatness and the bandwidth are stray capacitances at the output and inverting input. For minimizing the coupling, the space between signal lines and ground plane will be increased. Connections of the feedback components must be as short as possible in order to decrease the associated inductance which affect high frequency gain errors. It is very important to choose external components as small as possible such as surface mounted devices, SMD, in order to minimize the size of all the dc and ac connections.

**Power Supply Bypassing**

A proper power supply bypassing comes very important for optimizing the performance in high frequency range. Bypass capacitors must be placed as close as possible to the IC pins to improve high frequency bypassing. A capacitor greater than 1µF is necessary to minimize the distortion. For a better quality bypassing a capacitor of 0.1µF will be added following the same condition of implementation. These bypass capacitors must be incorporated for the negative and the positive supplies.

(fig.32): Circuit for power supply bypassing.

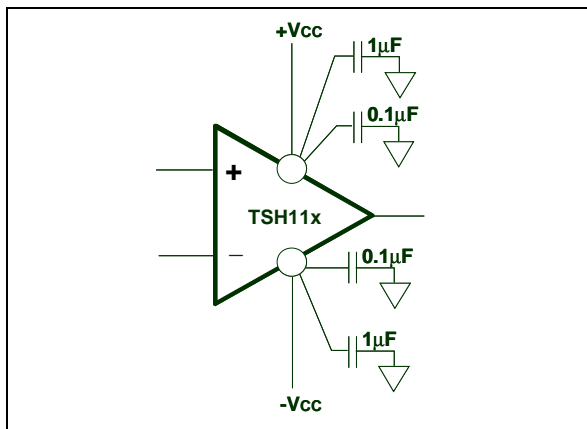

**Channel Separation or Crosstalk**

The following figure show the crosstalk from an amplifier to a second amplifier. This phenomenon, accented in high frequencies, is unavoidable and intrinsic of the circuit.

Nevertheless, the PCB layout has also an effect on the crosstalk level. Capacitive coupling between signal wires, distance between critical signal nodes, power supply bypassing, are the most significant points.

(fig.33): Crosstalk vs. Frequency.

$A_V=+2$ ,  $R_{fb}=680\Omega$ ,  $C_{fb}=2pF$ ,  $R_L=100\Omega$ ,  $V_{cc}=\pm 6V$ ,  $\pm 2.5V$

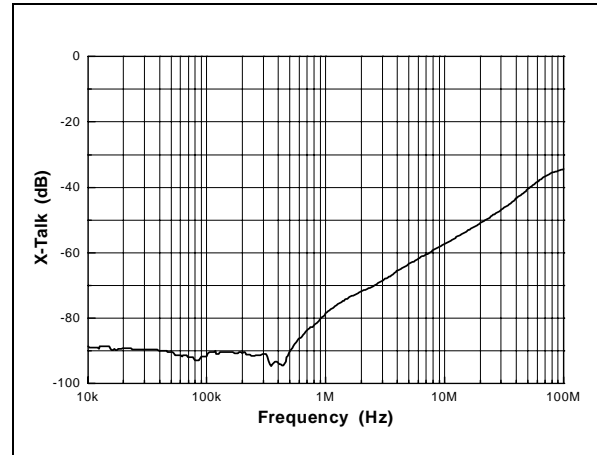

**Single Power Supply**

The TSH11x operates from 12V down to 5V power supplies. This is achieved with a dual power supply of ±6V and ±2.5V or a single power supply of 12V and 5V referenced to the ground. In the case of this asymmetrical supplying, a biasing is necessary to assume a positive output dynamic range between 0V and +Vcc supply rails. Considering the values of  $V_{OH}$  and  $V_{OL}$ , the amplifier will provide an output dynamic from +1.35V to 10.75V for a 12V supplying, from 0.6V to 4.5V for a 5V supplying.

The following figure show the case of a 5V single power supply configuration.

(fig.34): Circuit for +5V single supply.

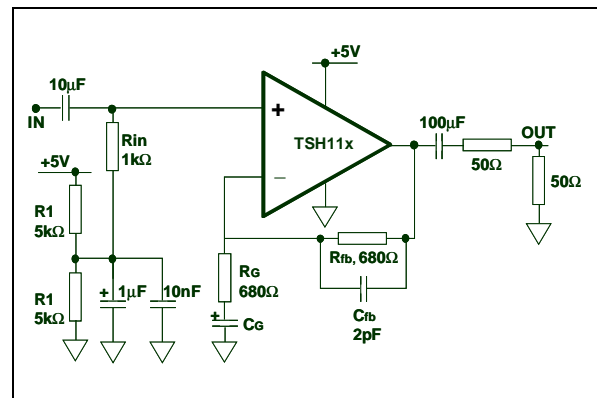

The amplifier must be biased with a mid supply (nominally  $+V_{cc}/2$ ), in order to maintain the DC component of the signal at this value. Several options are possible to provide this bias supply (such as a virtual ground using an operational amplifier), or a two-resistance divider which is the cheapest solution. A high resistance value is required to limit the current consumption. On the other hand, the current must be high enough to bias the non-inverting input of the amplifier. If we consider this bias current ( $5\mu A$ ) as the 1% of the current through the resistance divider ( $500\mu A$ ) to keep a stable mid supply, two  $5k\Omega$  resistances can be used.

The input provides a high pass filter with a break frequency below 10Hz which is necessary to remove the original 0 volt DC component of the input signal, and to hold it at 2.5V.

**Video Multiplexing using the TSH113**

(fig.35): Circuit for switching 3 video signals with the triple TSH113.

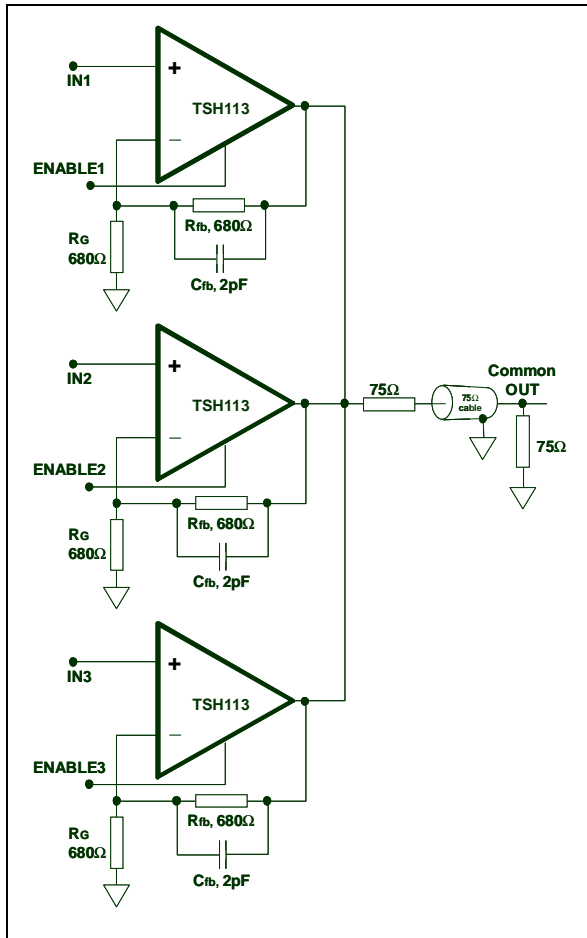

Assuming a low level active onto the disable pins (1,2,3) as described on page 7 of the datasheet, any operator can be disable/enable independently. The two disabled operators will be in standby mode featuring a high output impedance with a high input/output isolation and a low quiescent current.

(fig.36): Typical output response in standby mode on/off

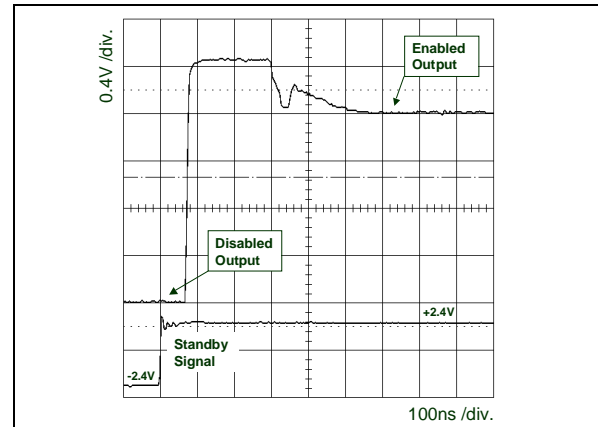

(fig.37): Typical output response in standby mode off/on

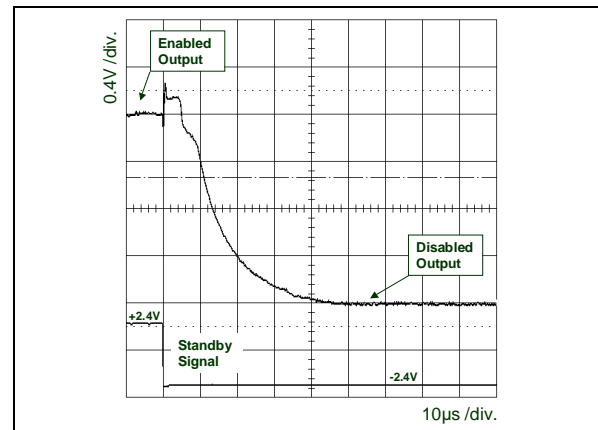

(fig.38): Input / Output Isolation vs. Frequency..

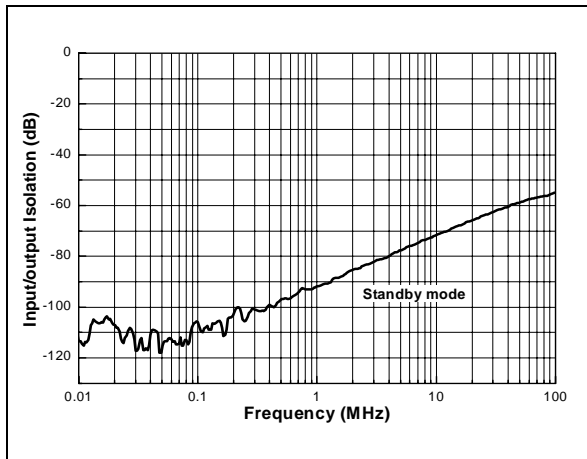

**Choice of the Feedback Circuit**

The TSH11x is a serie of current feedback amplifiers. For a current feedback structure the bandwidth depends on the value of the feedback components and the value of supply voltage.

A good choice of these components is necessary to achieve the gain flatness and the stability.

The following table shows the typical -3dB bandwidth and 0.1dB bandwidth assuming different gains and power supply on 100Ω load. Please see also the Closed Loop Gain vs. Frequency curves on page 8 of the datasheet.

(fig.39): Non-inverting and Inverting Implementation..

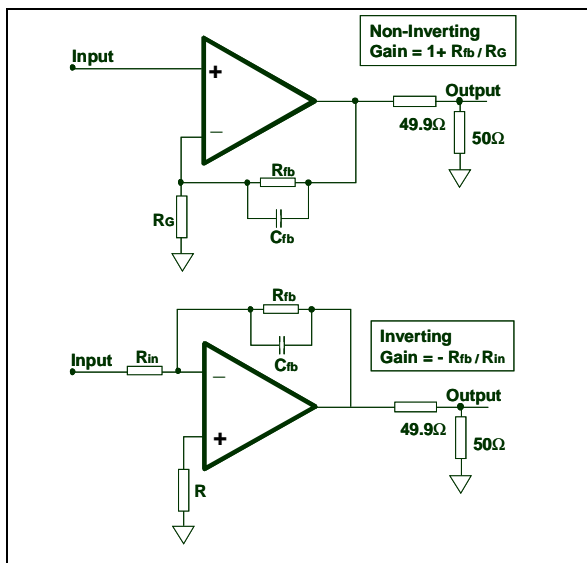

(tab.1): Closed-loop Gain and Feedback Components.

V <sub>CC</sub> (V)	Gain	R <sub>fb</sub> (Ω)	C <sub>fb</sub> (pF)	-3dB Bw (MHz)	0.1dB Bw (MHz)
±6	+10	510	-	46	14
	-10	510	-	42	13
	+2	680	2	105	50
	-2	680	2	90	40
	+1	2.2k	2	170	30
	-1	2.2k	2	110	20
±2.5	+10	510	-	37	13
	-10	510	-	36	12
	+2	680	2	93	25
	-2	680	2	86	30
	+1	2.2k	2	130	50
	-1	2.2k	2	100	18

**Inverting Amplifier Biasing**

In this case a resistance (R on fig.40) is necessary to achieve a good input biasing.

This resistance is calculated by assuming the negative and positive input bias current. The aim is to make the compensation of the offset bias current which could affect the input offset voltage and the output DC component.

Assuming Ib-, Ib+, Rin, Rfb and a zero volt output, the resistance R comes :  $R = R_{in} // R_{fb}$  .

(fig.40): Compensation of the Input Bias Current..

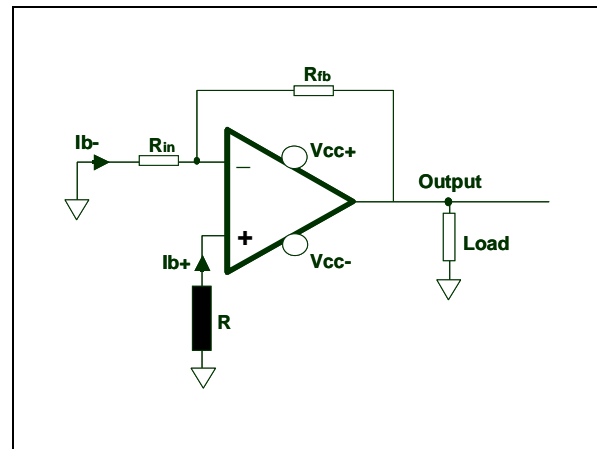



**PACKAGE MECHANICAL DATA**  
8 PINS - PLASTIC MICROPACKAGE (SO)

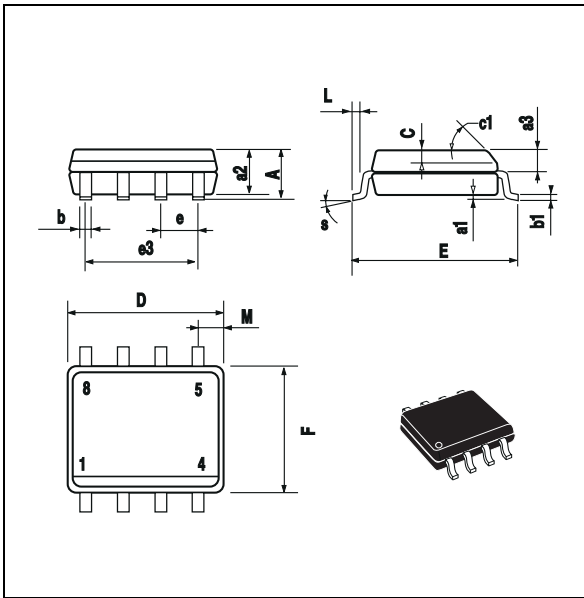

Dim.	Millimeters			Inches		
	Min.	Typ.	Max.	Min.	Typ.	Max.
A			1.75			0.069
a1	0.1		0.25	0.004		0.010
a2			1.65			0.065
a3	0.65		0.85	0.026		0.033
b	0.35		0.48	0.014		0.019
b1	0.19		0.25	0.007		0.010
C	0.25		0.5	0.010		0.020
c1	45° (typ.)					
D	4.8		5.0	0.189		0.197
E	5.8		6.2	0.228		0.244
e		1.27			0.050	
e3		3.81			0.150	
F	3.8		4.0	0.150		0.157
L	0.4		1.27	0.016		0.050
M			0.6			0.024
S	8° (max.)					

**PACKAGE MECHANICAL DATA**  
8 PINS - THIN SHRINK SMALL OUTLINE  
PACKAGE (TSSOP)

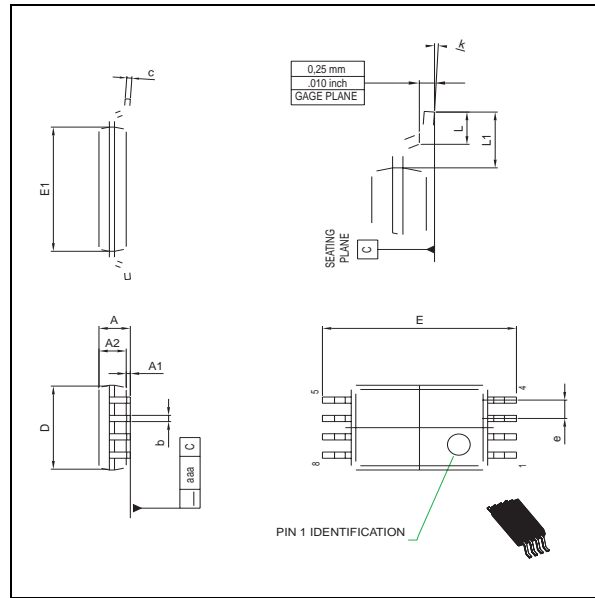

Dim.	Millimeters			Inches		
	Min.	Typ.	Max.	Min.	Typ.	Max.
A			1.20			0.05
A1	0.05		0.15	0.01		0.006
A2	0.80	1.00	1.05	0.031	0.039	0.041
b	0.19		0.30	0.007		0.15
c	0.09		0.20	0.003		0.012
D	2.90	3.00	3.10	0.114	0.118	0.122
E		6.40			0.252	
E1	4.30	4.40	4.50	0.169	0.173	0.177
e		0.65			0.025	
k	0°		8°	0°		8°
l	0.50	0.60	0.75	0.09	0.0236	0.030

**PACKAGE MECHANICAL DATA**

14 PINS - PLASTIC MICROPACKAGE (SO)

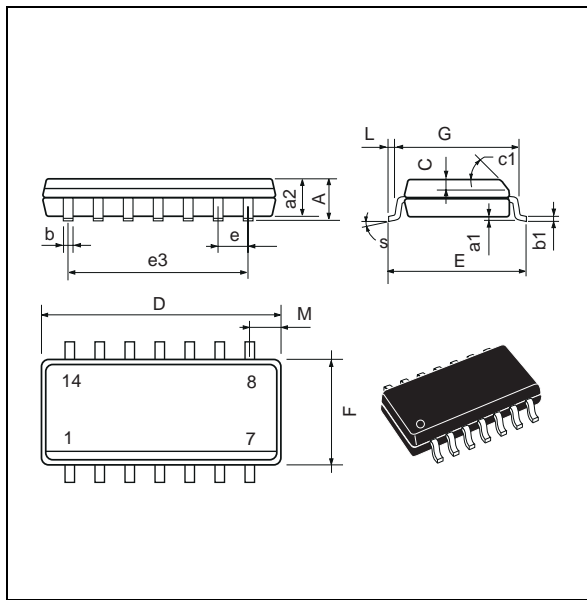

Dim.	Millimeters			Inches		
	Min.	Typ.	Max.	Min.	Typ.	Max.
A			1.75			0.069
a1	0.1		0.2	0.004		0.008
a2			1.6			0.063
b	0.35		0.46	0.014		0.018
b1	0.19		0.25	0.007		0.010
C		0.5			0.020	
c1	45° (typ.)					
D (1)	8.55		8.75	0.336		0.344
E	5.8		6.2	0.228		0.244
e		1.27			0.050	
e3		7.62			0.300	
F (1)	3.8		4.0	0.150		0.157
G	4.6		5.3	0.181		0.208
L	0.5		1.27	0.020		0.050
M			0.68			0.027
S	8° (max.)					

Note : (1) D and F do not include mold flash or protrusions - Mold flash or protrusions shall not exceed 0.15mm (.066 inc) ONLY FOR DATA BOOK.

**PACKAGE MECHANICAL DATA**

14 PINS - THIN SHRINK SMALL OUTLINE PACKAGE (TSSOP)

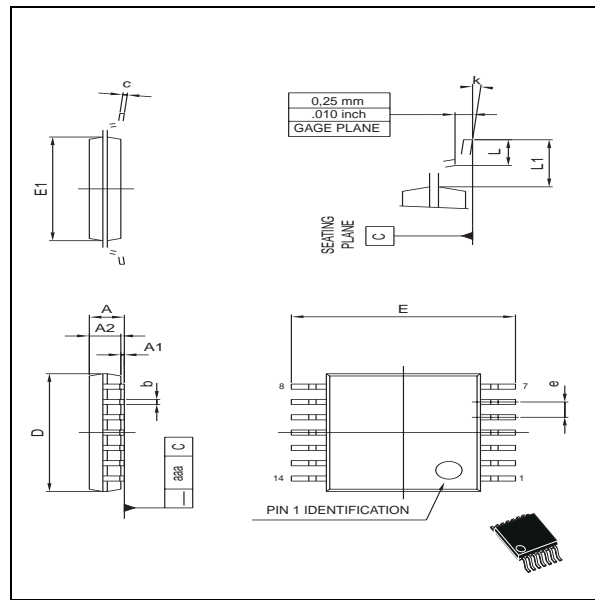

Dim.	Millimeters			Inches		
	Min.	Typ.	Max.	Min.	Typ.	Max.
A			1.20			0.05
A1	0.05		0.15	0.01		0.006
A2	0.80	1.00	1.05	0.031	0.039	0.041
b	0.19		0.30	0.007		0.15
c	0.09		0.20	0.003		0.012
D	4.90	5.00	5.10	0.192	0.196	0.20
E		6.40			0.252	
E1	4.30	4.40	4.50	0.169	0.173	0.177
e		0.65			0.025	
k	0°		8°	0°		8°
l	0.50	0.60	0.75	0.09	0.0236	0.030

**PACKAGE MECHANICAL DATA**  
 5 PINS - TINY PACKAGE (SOT23)

2

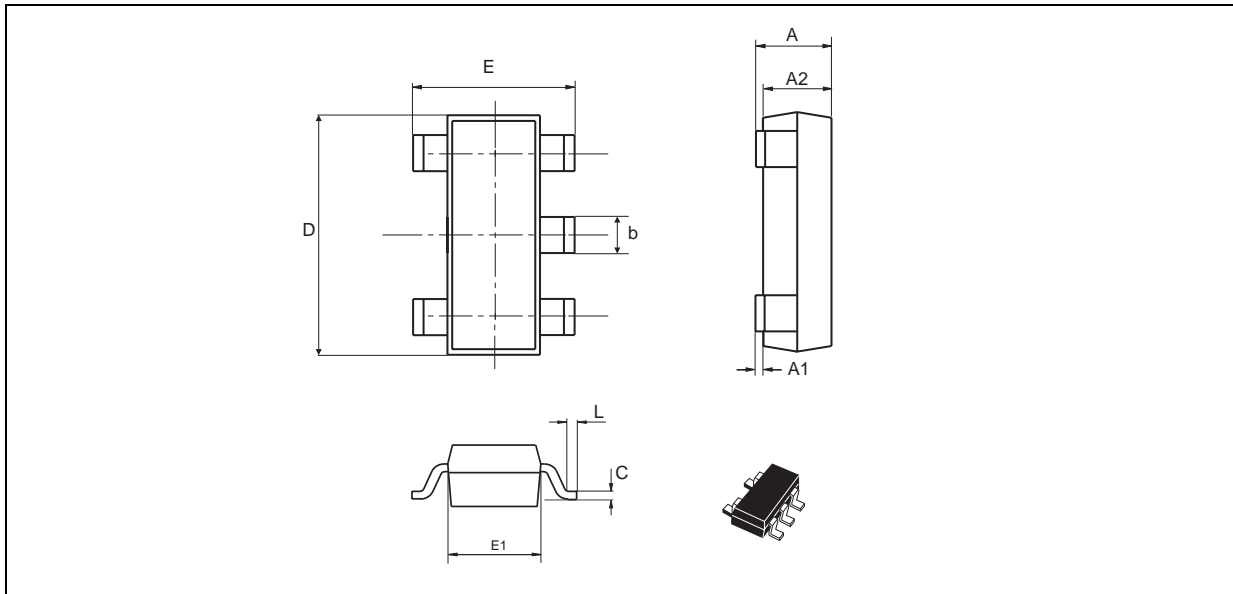

Dim.	Millimeters			Inches		
	Min.	Typ.	Max.	Min.	Typ.	Max.
A	0.90	1.20	1.45	0.035	0.047	0.057
A1	0		0.15			0.006
A2	0.90	1.05	1.30	0.035	0.041	0.051
B	0.35	0.40	0.50	0.014	0.016	0.020
C	0.09	0.15	0.20	0.004	0.006	0.008
D	2.80	2.90	3.00	0.110	0.114	0.118
D1		1.90			0.075	
e		0.95			0.037	
E	2.60	2.80	3.00	0.102	0.110	0.0118
F	1.50	1.60	1.75	0.059	0.063	0.069
L	0.10	0.5	0.60	0.004	0.014	0.024
K	0d		10d	0d		10d

Information furnished is believed to be accurate and reliable. However, STMicroelectronics assumes no responsibility for the consequences of use of such information nor for any infringement of patents or other rights of third parties which may result from its use. No license is granted by implication or otherwise under any patent or patent rights of STMicroelectronics. Specifications mentioned in this publication are subject to change without notice. This publication supersedes and replaces all information previously supplied. STMicroelectronics products are not authorized for use as critical components in life support devices or systems without express written approval of STMicroelectronics.

© The ST logo is a registered trademark of STMicroelectronics

© 2002 STMicroelectronics - Printed in Italy - All Rights Reserved  
 STMicroelectronics GROUP OF COMPANIES

Australia - Brazil - Canada - China - Finland - France - Germany - Hong Kong - India - Israel - Italy - Japan - Malaysia  
 Malta - Morocco - Singapore - Spain - Sweden - Switzerland - United Kingdom - United States

© <http://www.st.com>

