



VN340SP

QUAD HIGH SIDE SMART POWER SOLID STATE RELAY

TYPE	V _{demag} *	R _{DS(on)} *	I _{OUT} *	V _{CC}
VN340SP	V _{CC} -55V	0.32 Ω**	0.7 A	36 V

* per Channel
 **at T_J = 85 °C

- OUTPUT CURRENT: 0.7A PER CHANNEL
- DIGITAL I/O's CLAMPED AT 32V MINIMUM VOLTAGE
- SHORTED LOAD AND OVERTEMPERATURE PROTECTIONS
- BUILT-IN CURRENT LIMITER
- UNDER VOLTAGE SHUT DOWN
- OPEN DRAIN DIAGNOSTIC OUTPUT
- FAST DEMAGNETIZATION OF INDUCTIVE LOADS
- PROTECTION AGAINST LOSS OF GROUND
- CONFORMS TO IEC 1131-2

DESCRIPTION

The VN340SP is a monolithic device made using STMicroelectronics VIPower Technology, intended for driving four independent resistive or inductive loads with one side connected to

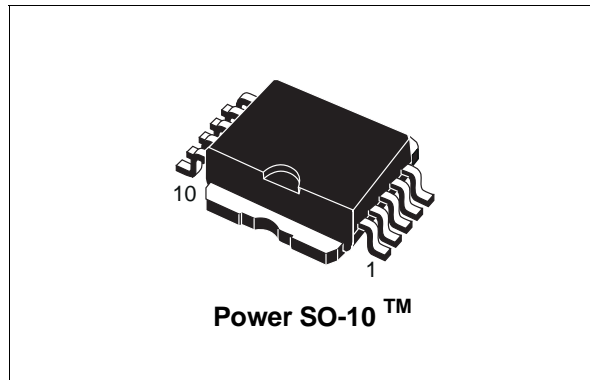

ground.

Active current limitation avoids dropping the system power supply in case of shorted load.

Built-in thermal shut-down protects the chip from over temperature and short circuit.

The open drain diagnostic output indicates overtemperature conditions. Each I/O is pulled down when over temperature condition of the relative channel is verified.

BLOCK DIAGRAM

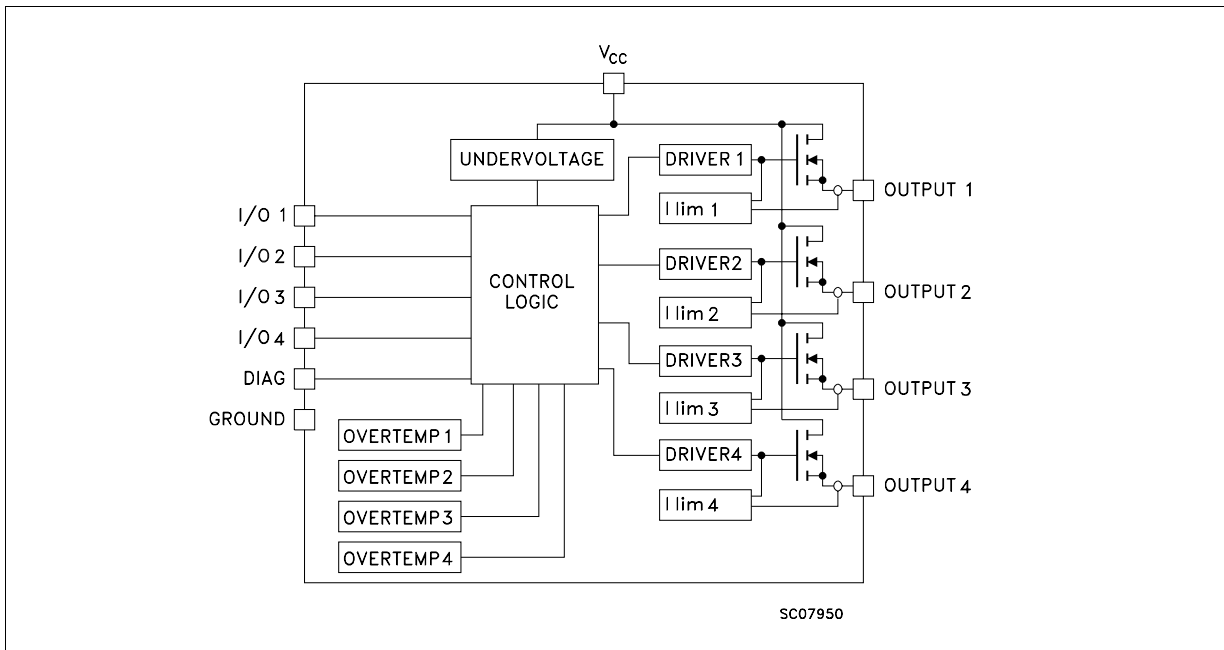

VN340SP

ABSOLUTE MAXIMUM RATING

Symbol	Parameter	Value	Unit
V_{CC}	Power Supply Voltage	45	V
$-V_{CC}$	Reverse Supply Voltage	-4	V
I_{OUT}	Output Current (cont.)	Internally Limited	A
I_R	Reverse Output Current (per channel)	-6	A
I_{IN}	Input Current (per channel)	± 10	mA
I_{DIAG}	DIAG Pin Current	± 10	mA
V_{ESD}	Electrostatic Discharge (1.5 k Ω , 100 pF)	2000	V
E_{AS}	Single Pulse Avalanche Energy per Channel Not Simultaneously (see figure 1)	400	mJ
P_{tot}	Power Dissipation at $T_c \leq 25^\circ C$	Internally Limited	W
T_j	Junction Operating Temperature	Internally Limited	$^\circ C$
T_{stg}	Storage Temperature	-55 to 150	$^\circ C$

CONNECTION DIAGRAM

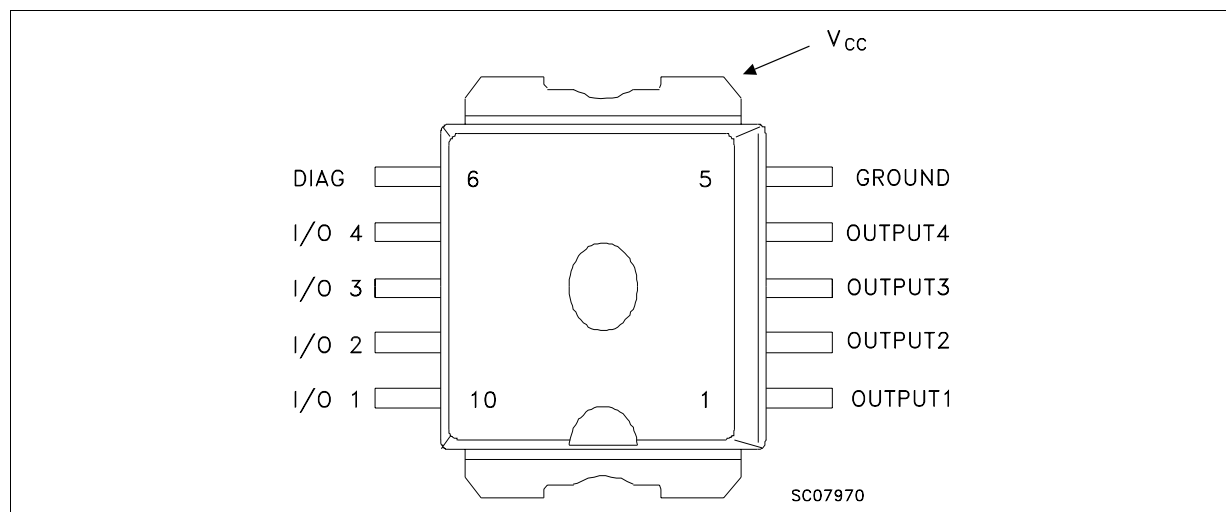

CURRENT AND VOLTAGE CONVENTIONS

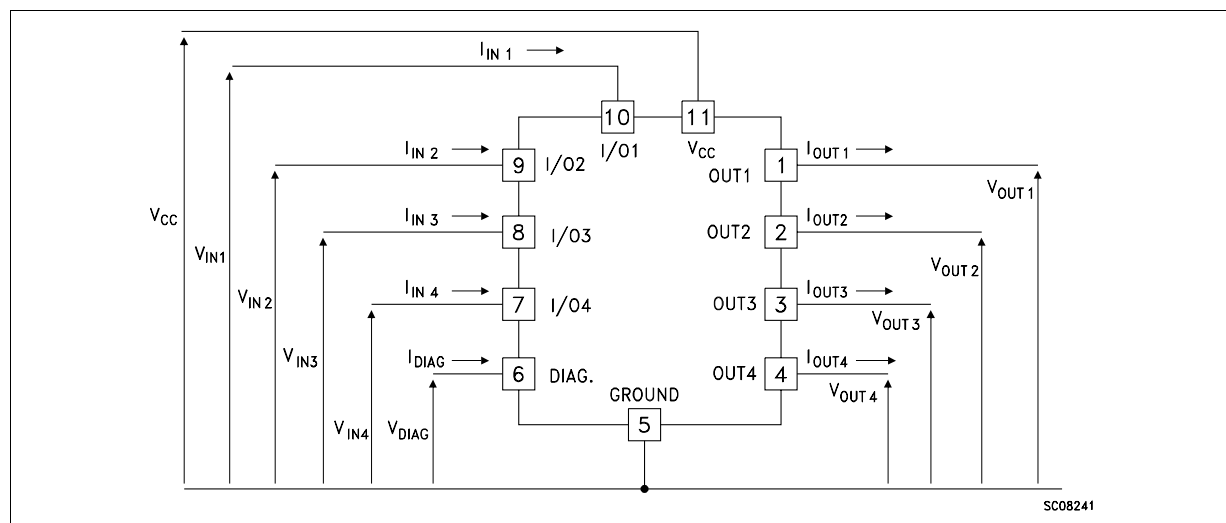

THERMAL DATA

R _{thj-case}	Thermal Resistance Junction-case (1)	Max	3	°C/W
R _{thj-amb}	Thermal Resistance Junction-ambient (\$)	Max	50	°C/W

(1) Per channel

(\$) When mounted using minimum recommended pad size on FR-4 board

ELECTRICAL CHARACTERISTICS (10V < V_{CC} < 36V; -25 °C < T_J < 85 °C unless otherwise specified)
POWER

Symbol	Parameter	Test Conditions	Min.	Typ.	Max.	Unit
V _{CC}	Supply Voltage		10		36	V
R _{on}	On State Resistance	I _{OUT} = 0.5 A T _J = 125 °C I _{OUT} = 0.5 A			0.4 0.32	Ω Ω
I _S	Supply Current	All Channels Off On State V _{IN} = 30 V I _{out1} .. I _{out4} = 0 (T _J = 125 °C)			1 6	mA mA
V _{demag}	Output Voltage at Turn-Off	I _{out} = 0.5A L _{LOAD} = 1 mH	V _{CC} -65	V _{CC} -55	V _{CC} -45	V
V _{OL}	Low State Output Voltage	V _{IN} = V _{IL} R _{LOAD} = 10MΩ			1.5	V
I _{Ignd}	Output Current at Turn-Off	V _{CC} = V _{INX} = GND = DIAG = 18 to 30 V T _{amb} = -25 °C to 85 °C *			2	mA

* (see test configuration and application description)

SWITCHING (V_{CC} = 24 V)

Symbol	Parameter	Test Conditions	Min.	Typ.	Max.	Unit
t _{d(on)}	Turn-on Delay Time Of Output Current	I _{OUT} = 0.5 A Resistive Load Input Rise Time < 0.1 μs T _J = 25 °C		52	100	μs
t _r	Rise Time Of Output Current	I _{OUT} = 0.5 A Resistive Load Input Rise Time < 0.1 μs T _J = 25 °C		94	250	μs
t _{d(off)}	Turn-off Delay Time Of Output Current	I _{OUT} = 0.5 A Resistive Load Input Rise Time < 0.1 μs T _J = 25 °C		34	50	μs
t _f	Fall Time Of Output Current	I _{OUT} = 0.5 A Resistive Load Input Rise Time < 0.1 μs T _J = 25 °C		8	20	μs

ELECTRICAL CHARACTERISTICS (continued)

LOGIC INPUT (Each Channel)

Symbol	Parameter	Test Conditions	Min.	Typ.	Max.	Unit
V _{IL}	I/O Input Low Level Voltage				2	V
V _{IH}	I/O Input High Level Voltage (see note1)		3.5			V
V _{I(hyst.)}	I/O Input Hysteresis Voltage			0.5		V
I _{IN}	I/O Input Current	V _{IN} = 30 V			25	μA
V _{ICL}	I/O Input Clamp Voltage (see note1)	I _{IN} = 1 mA I _{IN} = -1 mA	32	36 -0.7		V V

note 1 : The input voltage is internally clamped at 32V minimum, it is possible to connect the input pins to an higher voltage via an external resistor calculate to not exceed 10 mA

PROTECTION AND DIAGNOSTICS

Symbol	Parameter	Test Conditions	Min.	Typ.	Max.	Unit
V _{DIAG} (●)	Status Voltage Output Low	I _{STAT} = 5 mA (Fault Condition)			1	V
V _{SCL} (●)	Status Clamp Voltage	I _{STAT} = 1 mA I _{STAT} = -1 mA	32	36 -0.7		V V
V _{USD}	Under Voltage Shut Down		5		8	V
I _{LIM}	DC Short Circuit Current	V _{CC} = 24 V R _{LOAD} < 10 mΩ	0.7		2	A
I _{OVPK}	Peak Short Circuit Current	V _{CC} = 24 V V _{IN} = 30 V R _{LOAD} < 10 mΩ (see fig.2)			4	A
I _{DIAGH}	Leakage on diag pin in high state	V _{DIAG} = 24 V			25	μA
I _{LOAD}	Output Leakage Current	V _{CC} = 10 to 36 V V _{IN} = V _{IL}			50	μA
t _{SC}	Delay Time of Current Limiter				100	μs
T _{TSD}	Thermal Shut-down Temperature		150	170		°C
T _R	Reset Temperature		135	155		°C

(●) Status determination > 100 μs after the switching edge.

Note: If INPUTn pin is left floating the corresponding channel will automatically switch off. If GND pin is disconnected, all channels will switch off provided V_{CC} does not exceed 36V

FIGURE 1: Avalanche Energy Test Circuit

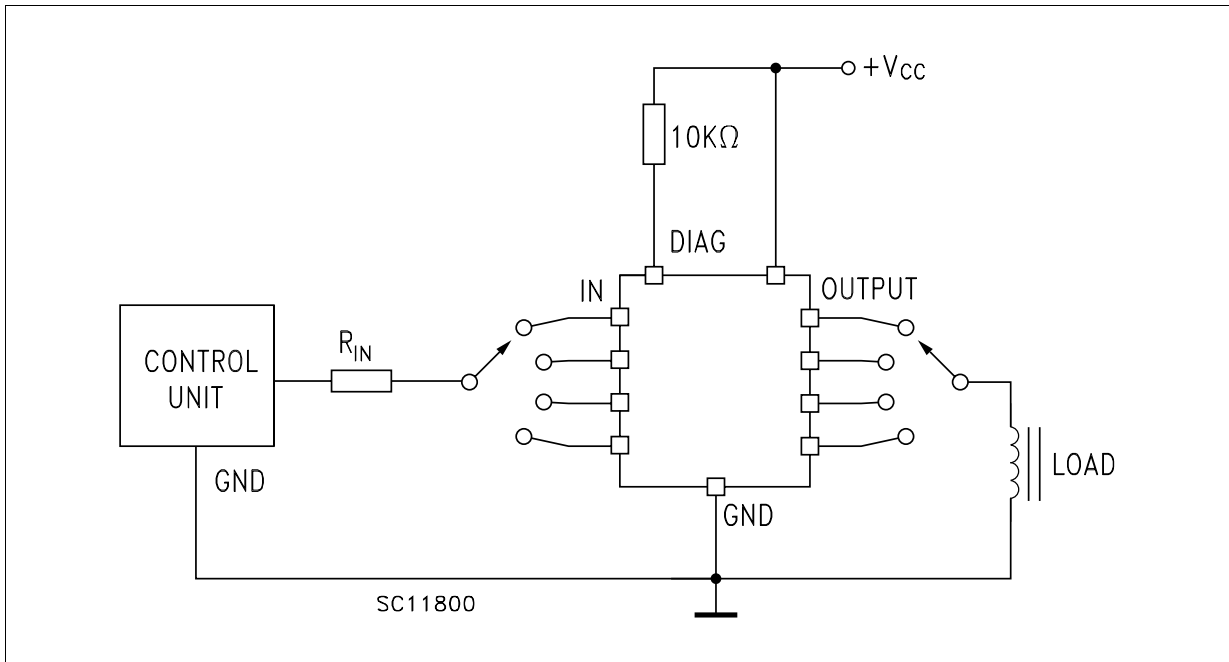
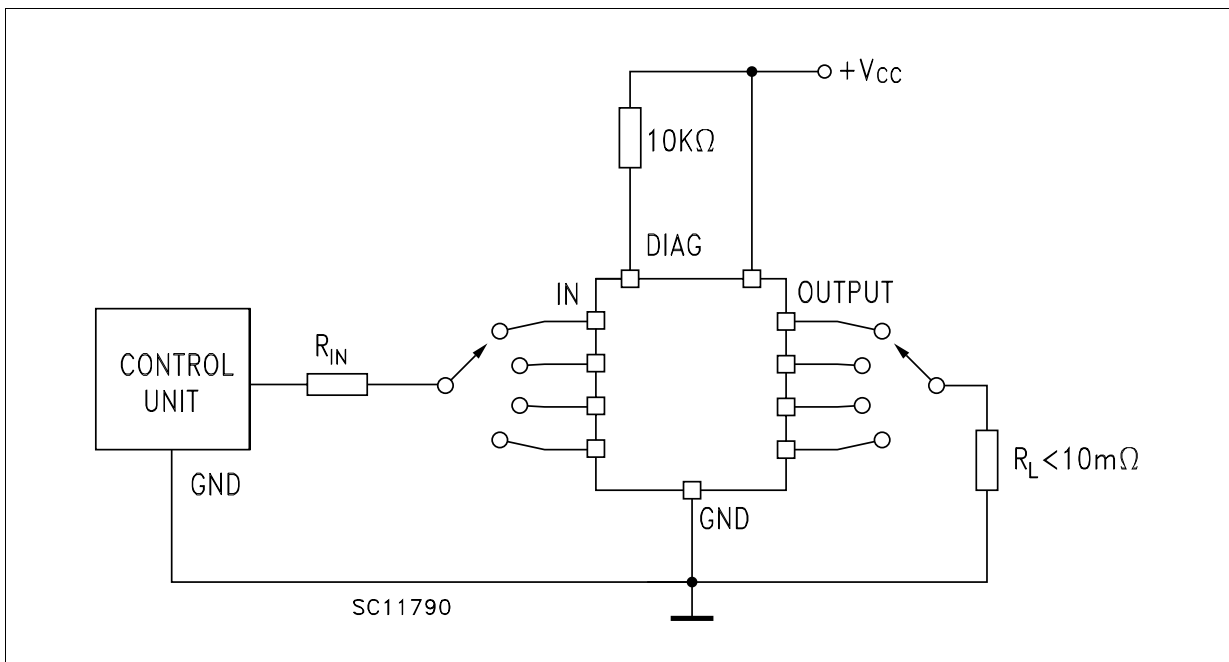

FIGURE 2: Peak Short Circuit Current Test Circuit



TRUTH TABLE

	MCOU _{Tn}	I/O _n	OUTPUT _n	DIAGNOSTIC
Normal Operation	L	L	L	H
	H	H	H	H
Over-temperature	L	L	L	H
	H	L	L	L
Under-voltage	L	L	L	H
	H	H	L	H
Shorted Load (current limitation)	L	L	L	H
	H	H	H	H

FIGURE 3: Switching Waveforms

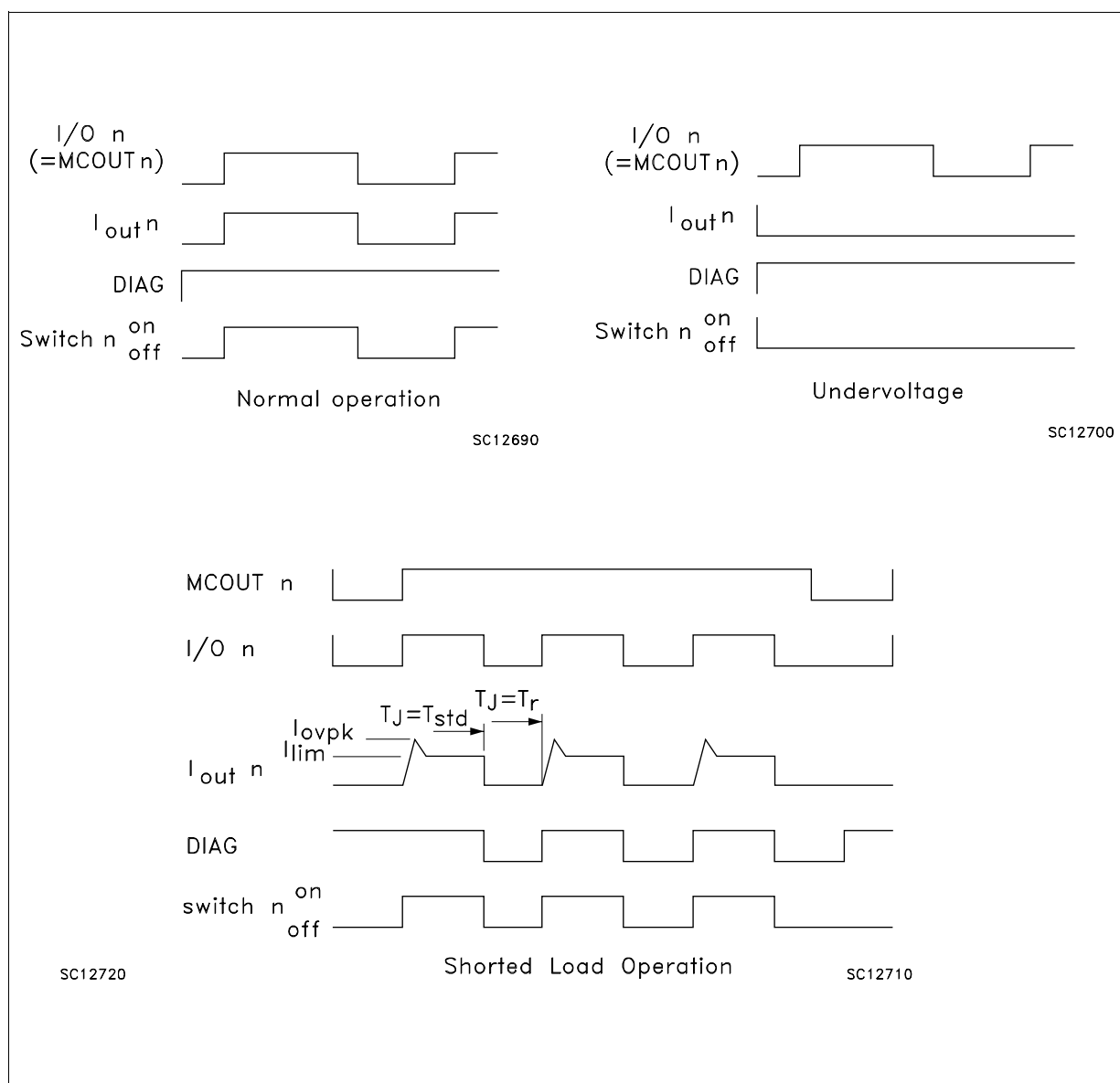

SWITCHING PARAMETERS TEST CONDITIONS

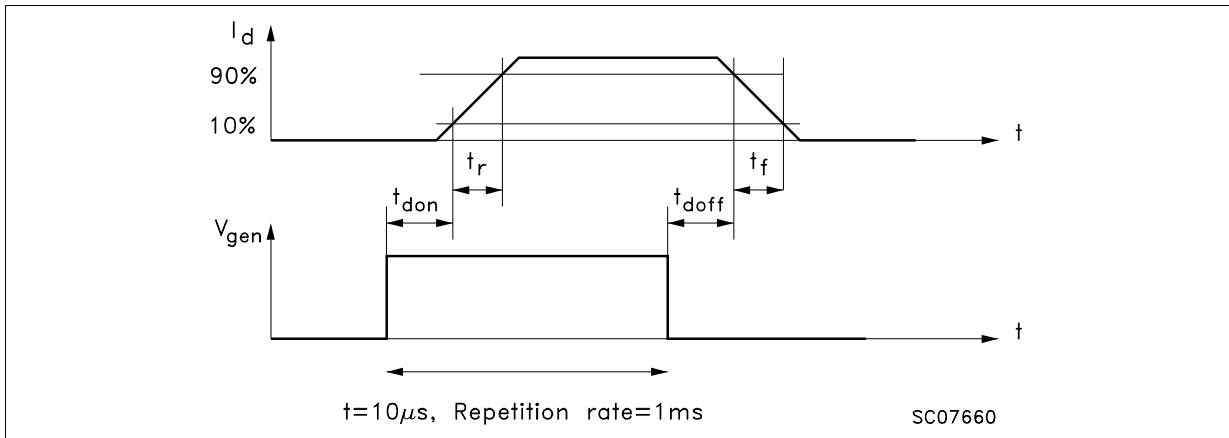

DRIVING CIRCUIT

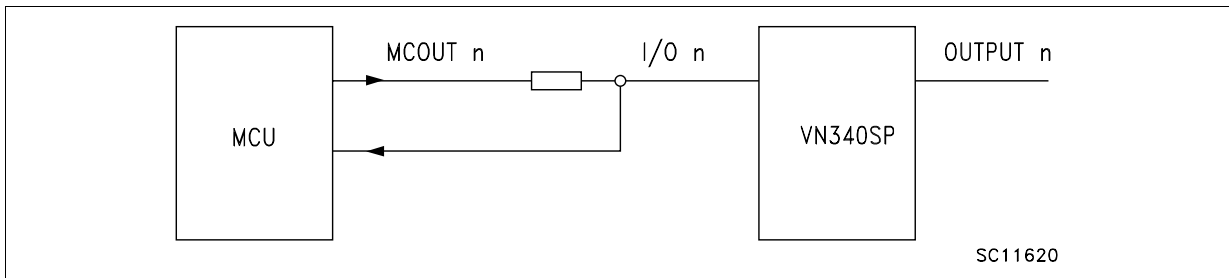
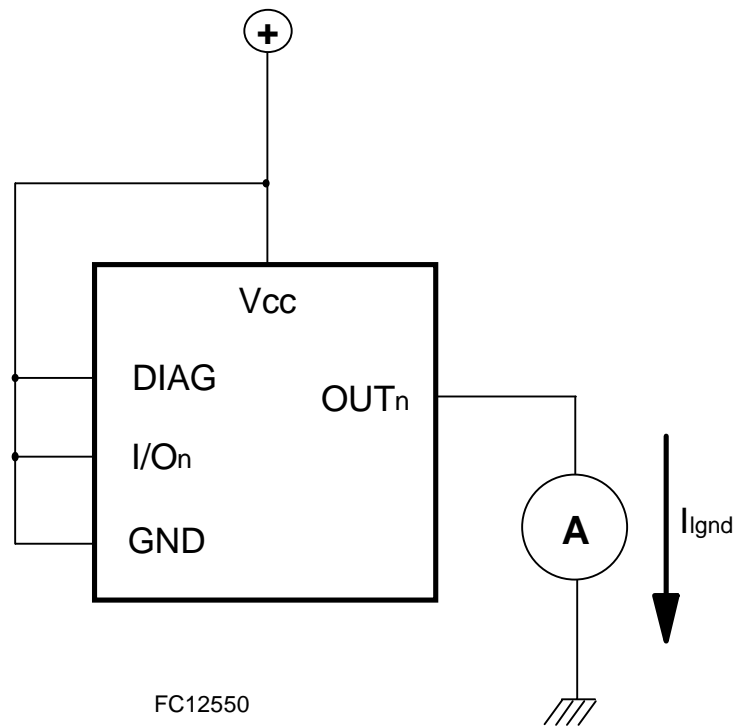
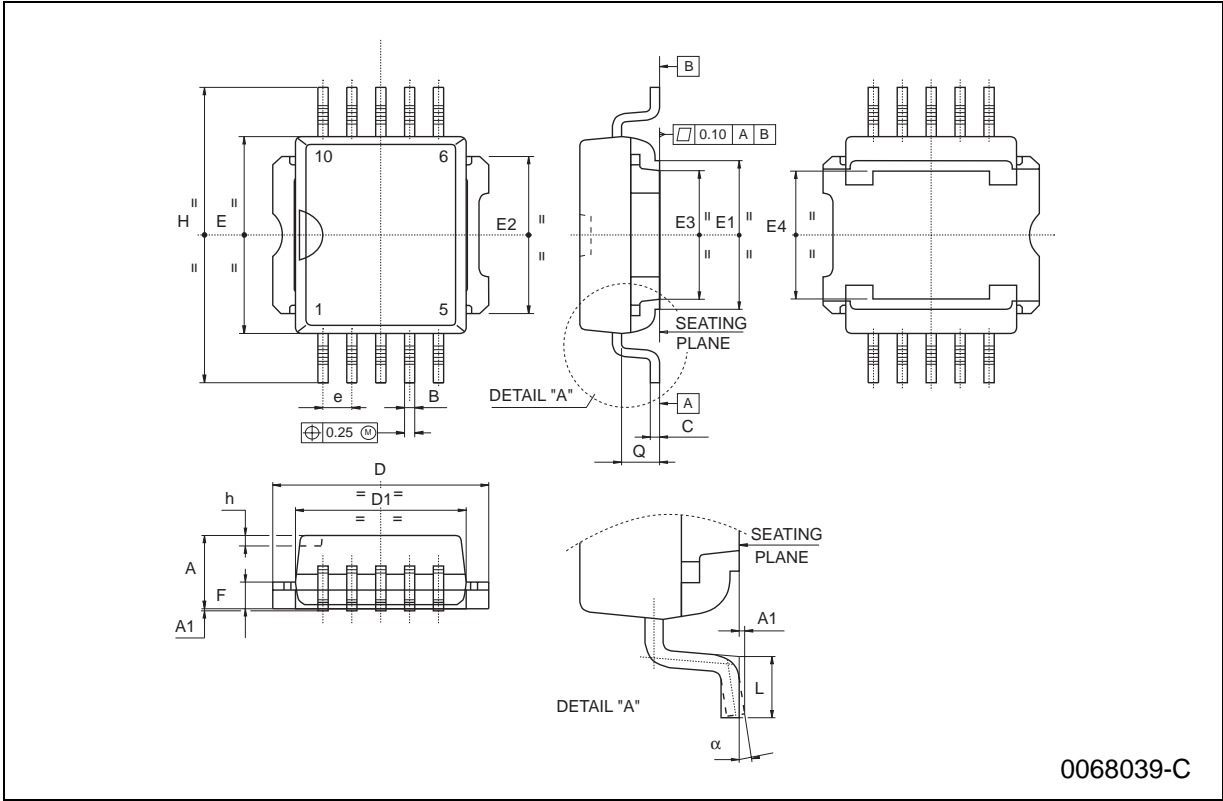

Figure 4: I_{LGND} Test Configuration



PowerSO-10 MECHANICAL DATA

DIM.	mm			inch		
	MIN.	TYP.	MAX.	MIN.	TYP.	MAX.
A	3.35		3.65	0.132		0.144
A1	0.00		0.10	0.000		0.004
B	0.40		0.60	0.016		0.024
c	0.35		0.55	0.013		0.022
D	9.40		9.60	0.370		0.378
D1	7.40		7.60	0.291		0.300
E	9.30		9.50	0.366		0.374
E1	7.20		7.40	0.283		0.291
E2	7.20		7.60	0.283		0.300
E3	6.10		6.35	0.240		0.250
E4	5.90		6.10	0.232		0.240
e		1.27			0.050	
F	1.25		1.35	0.049		0.053
H	13.80		14.40	0.543		0.567
h		0.50			0.002	
L	1.20		1.80	0.047		0.071
q		1.70			0.067	
α	0°		8°			



0068039-C



Information furnished is believed to be accurate and reliable. However, STMicroelectronics assumes no responsibility for the consequences of use of such information nor for any infringement of patents or other rights of third parties which may result from its use. No license is granted by implication or otherwise under any patent or patent rights of STMicroelectronics. Specification mentioned in this publication are subject to change without notice. This publication supersedes and replaces all information previously supplied. STMicroelectronics products are not authorized for use as critical components in life support devices or systems without express written approval of STMicroelectronics.

The ST logo is a trademark of STMicroelectronics

© 1999 STMicroelectronics – Printed in Italy – All Rights Reserved

STMicroelectronics GROUP OF COMPANIES

Australia - Brazil - Canada - China - France - Germany - Italy - Japan - Korea - Malaysia - Malta - Mexico - Morocco - The Netherlands - Singapore - Spain - Sweden - Switzerland - Taiwan - Thailand - United Kingdom - U.S.A.

<http://www.st.com>