



# VND810PEP

## DOUBLE CHANNEL HIGH SIDE DRIVER

### TARGET SPECIFICATION

TYPE	R <sub>DS(on)</sub>	I <sub>OUT</sub>	V <sub>CC</sub>
VND810PEP	160 mΩ (*)	3.5 A (*)	36 V

(\*) Per each channel

- CMOS COMPATIBLE INPUTS
- OPEN DRAIN STATUS OUTPUTS
- ON STATE OPEN LOAD DETECTION
- OFF STATE OPEN LOAD DETECTION
- SHORTED LOAD PROTECTION
- UNDERVOLTAGE AND OVERVOLTAGE SHUTDOWN
- PROTECTION AGAINST LOSS OF GROUND
- VERY LOW STAND-BY CURRENT
- REVERSE BATTERY PROTECTION (\*\*)

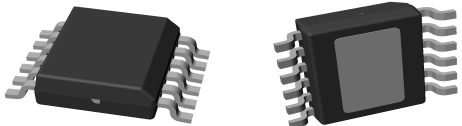

**PowerSSO-12**

ORDER CODES		
PACKAGE	TUBE	T&R
PowerSSO-12	VND810PEP	VND810PEP13TR

### DESCRIPTION

The VND810PEP is a monolithic device designed in STMicroelectronics VIpower M0-3 Technology, intended for driving any kind of load with one side connected to ground. Active V<sub>CC</sub> pin voltage clamp protects the device against low energy spikes (see ISO7637 transient compatibility table). Active current limitation

combined with thermal shutdown and automatic restart protects the device against overload. The device detects open load condition both in on and off state. Output shorted to V<sub>CC</sub> is detected in the off state. Device automatically turns off in case of ground pin disconnection.

### BLOCK DIAGRAM

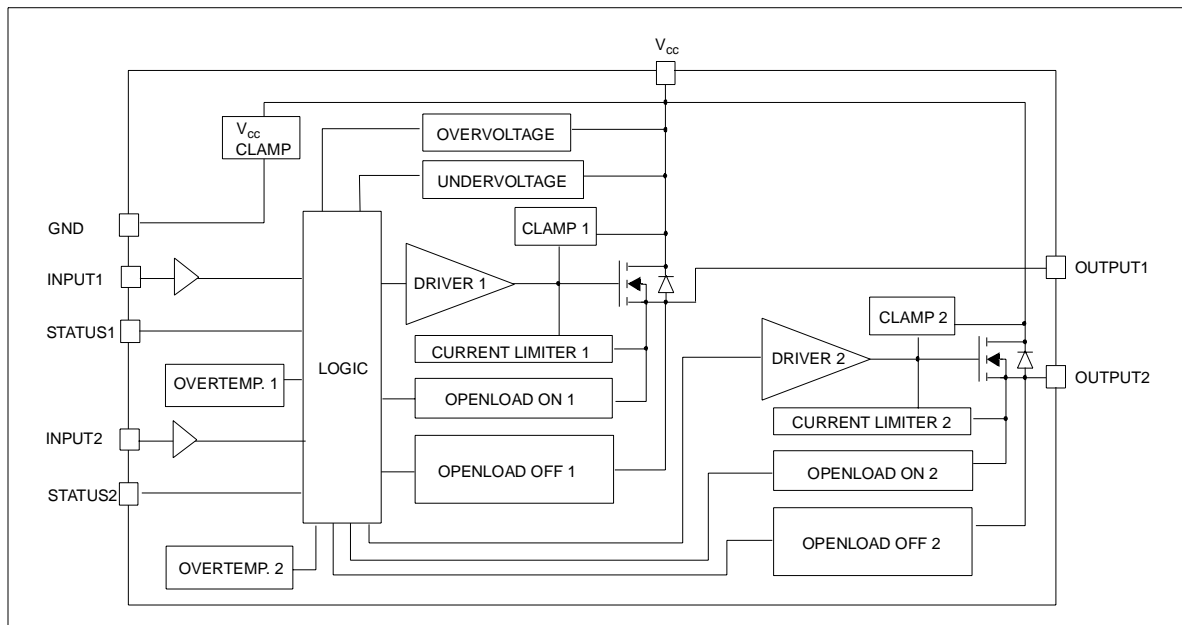

(\*\*) See application schematic at page 8

# VND810PEP

## ABSOLUTE MAXIMUM RATING

Symbol	Parameter	Value	Unit
$V_{CC}$	DC Supply Voltage	41	V
$-V_{CC}$	Reverse DC Supply Voltage	- 0.3	V
$-I_{GND}$	DC Reverse Ground Pin Current	- 200	mA
$I_{OUT}$	DC Output Current	Internally Limited	A
$-I_{OUT}$	Reverse DC Output Current	- 6	A
$I_{IN}$	DC Input Current	+/- 10	mA
$I_{stat}$	DC Status Current	+/- 10	mA
$V_{ESD}$	Electrostatic Discharge (Human Body Model: R=1.5K $\Omega$ ; C=100pF)		
	- INPUT	4000	V
	- STATUS	4000	V
	- OUTPUT	5000	V
	- $V_{CC}$	5000	V
$P_{tot}$	Power Dissipation $T_C=25^{\circ}C$	54	W
$T_j$	Junction Operating Temperature	Internally Limited	$^{\circ}C$
$T_C$	Case Operating Temperature	- 40 to 150	$^{\circ}C$
$T_{stg}$	Storage Temperature	- 55 to 150	$^{\circ}C$

## CONNECTION DIAGRAM (TOP VIEW)

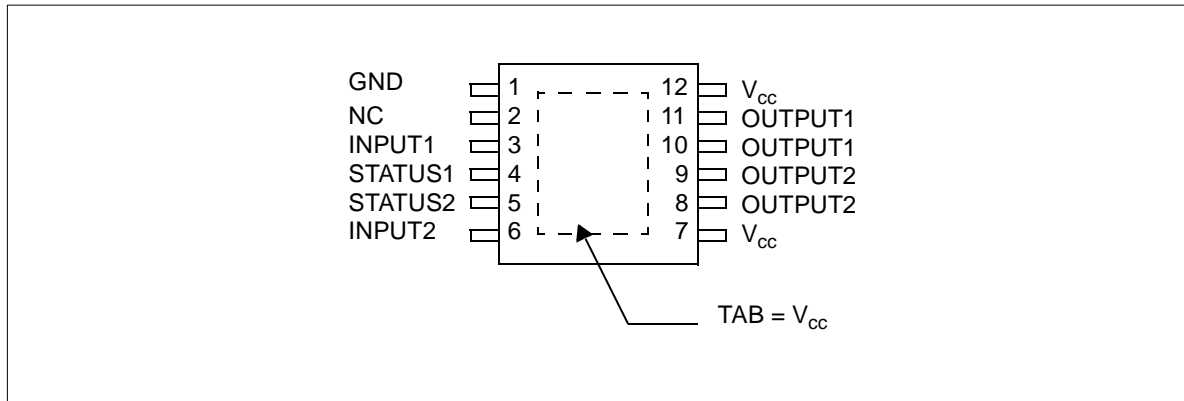

## CURRENT AND VOLTAGE CONVENTIONS

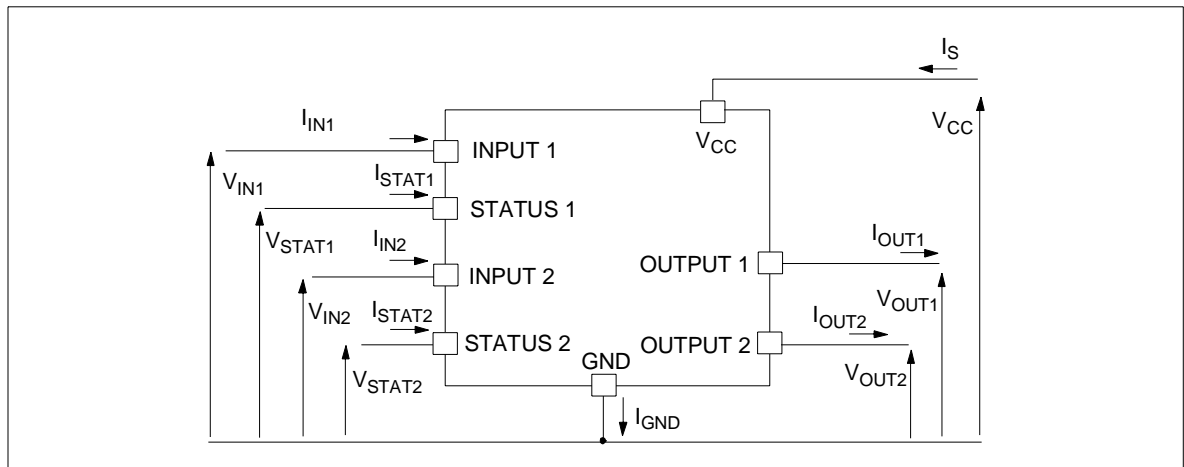

## THERMAL DATA

Symbol	Parameter	Value	Unit
R <sub>thj-case</sub>	Thermal Resistance Junction-case	2.3	°C/W
R <sub>thj-amb</sub>	Thermal Resistance Junction-ambient	70 (*)	°C/W

(\*) When mounted on a standard single-sided FR-4 board with 1 cm<sup>2</sup> of Cu (at least 35µm thick) connected to all V<sub>CC</sub> pins.

**ELECTRICAL CHARACTERISTICS** (8V < V<sub>CC</sub> < 36V; -40°C < T<sub>j</sub> < 150°C, unless otherwise specified)

(Per each channel)

## POWER OUTPUTS

Symbol	Parameter	Test Conditions	Min	Typ	Max	Unit
V <sub>CC</sub>	Operating Supply Voltage		5.5	13	36	V
V <sub>USD</sub>	Undervoltage Shut-down		3	4	5.5	V
V <sub>OV</sub>	Overvoltage Shut-down		36			V
R <sub>ON</sub>	On State Resistance	I <sub>OUT</sub> =1A; T <sub>j</sub> =25°C I <sub>OUT</sub> =1A; V <sub>CC</sub> >8V			160 320	mΩ mΩ
I <sub>S</sub>	Supply Current	Off State; V <sub>CC</sub> =13V; V <sub>IN</sub> =V <sub>OUT</sub> =0V Off State; V <sub>CC</sub> =13V; V <sub>IN</sub> =V <sub>OUT</sub> =0V; T <sub>j</sub> =25°C On State; V <sub>CC</sub> =13V; V <sub>IN</sub> =5V; I <sub>OUT</sub> =0A		12 12 5	40 25 7	µA µA mA
I <sub>L(off1)</sub>	Off State Output Current	V <sub>IN</sub> =V <sub>OUT</sub> =0V	0		50	µA
I <sub>L(off2)</sub>	Off State Output Current	V <sub>IN</sub> =0V; V <sub>OUT</sub> =3.5V	-75		0	µA
I <sub>L(off3)</sub>	Off State Output Current	V <sub>IN</sub> =V <sub>OUT</sub> =0V; V <sub>CC</sub> =13V; T <sub>j</sub> =125°C			5	µA
I <sub>L(off4)</sub>	Off State Output Current	V <sub>IN</sub> =V <sub>OUT</sub> =0V; V <sub>CC</sub> =13V; T <sub>j</sub> =25°C			3	µA

SWITCHING (V<sub>CC</sub>=13V)

Symbol	Parameter	Test Conditions	Min	Typ	Max	Unit
t <sub>d(on)</sub>	Turn-on Delay Time	R <sub>L</sub> =13Ω from V <sub>IN</sub> rising edge to V <sub>OUT</sub> =1.3V		30		µs
t <sub>d(off)</sub>	Turn-off Delay Time	R <sub>L</sub> =13Ω from V <sub>IN</sub> falling edge to V <sub>OUT</sub> =11.7V		30		µs
dV <sub>OUT</sub> /dt <sub>(on)</sub>	Turn-on Voltage Slope	R <sub>L</sub> =13Ω from V <sub>OUT</sub> =1.3V to V <sub>OUT</sub> =10.4V		0.6		V/µs
dV <sub>OUT</sub> /dt <sub>(off)</sub>	Turn-off Voltage Slope	R <sub>L</sub> =13Ω from V <sub>OUT</sub> =11.7V to V <sub>OUT</sub> =1.3V		0.2		V/µs

## LOGIC INPUT

Symbol	Parameter	Test Conditions	Min	Typ	Max	Unit
V <sub>IL</sub>	Input Low Level				1.25	V
I <sub>IL</sub>	Low Level Input Current	V <sub>IN</sub> = 1.25V	1			µA
V <sub>IH</sub>	Input High Level		3.25			V
I <sub>IH</sub>	High Level Input Current	V <sub>IN</sub> = 3.25V			10	µA
V <sub>I(hyst)</sub>	Input Hysteresis Voltage		0.5			V
V <sub>ICL</sub>	Input Clamp Voltage	I <sub>IN</sub> = 1mA I <sub>IN</sub> = -1mA	6	6.8 -0.7	8	V V

V<sub>CC</sub> - OUTPUT DIODE

Symbol	Parameter	Test Conditions	Min	Typ	Max	Unit
V <sub>F</sub>	Forward on Voltage	-I <sub>OUT</sub> =0.5A; T <sub>j</sub> =150°C			0.6	V

## VND810PEP

### ELECTRICAL CHARACTERISTICS (continued)

#### STATUS PIN

Symbol	Parameter	Test Conditions	Min	Typ	Max	Unit
$V_{STAT}$	Status Low Output Voltage	$I_{STAT}= 1.6 \text{ mA}$			0.5	V
$I_{LSTAT}$	Status Leakage Current	Normal Operation; $V_{STAT}= 5\text{V}$			10	$\mu\text{A}$
$C_{STAT}$	Status Pin Input Capacitance	Normal Operation; $V_{STAT}= 5\text{V}$			100	pF
$V_{SCL}$	Status Clamp Voltage	$I_{STAT}= 1\text{mA}$	6	6.8	8	V
		$I_{STAT}= -1\text{mA}$		-0.7		V

#### PROTECTIONS

Symbol	Parameter	Test Conditions	Min	Typ	Max	Unit
$T_{TSD}$	Shut-down Temperature		150	175	200	$^{\circ}\text{C}$
$T_R$	Reset Temperature		135			$^{\circ}\text{C}$
$T_{hyst}$	Thermal Hysteresis		7	15		$^{\circ}\text{C}$
$t_{SDL}$	Status Delay in Overload Conditions	$T_j > T_{TSD}$			20	$\mu\text{s}$
$I_{lim}$	Current limitation	$5.5\text{V} < V_{CC} < 36\text{V}$	3.5	5	7.5	A
					7.5	A
$V_{demag}$	Turn-off Output Clamp Voltage	$I_{OUT}=1\text{A}; L=6\text{mH}$	$V_{CC}-41$	$V_{CC}-48$	$V_{CC}-55$	V

#### OPENLOAD DETECTION

Symbol	Parameter	Test Conditions	Min	Typ	Max	Unit
$I_{OL}$	Openload ON State Detection Threshold	$V_{IN}=5\text{V}$	20	40	80	mA
$t_{DOL(on)}$	Openload ON State Detection Delay	$I_{OUT}=0\text{A}$			200	$\mu\text{s}$
$V_{OL}$	Openload OFF State Voltage Detection Threshold	$V_{IN}=0\text{V}$	1.5	2.5	3.5	V
$t_{DOL(off)}$	Openload Detection Delay at Turn Off				1000	$\mu\text{s}$

OPEN LOAD STATUS TIMING (with external pull-up)

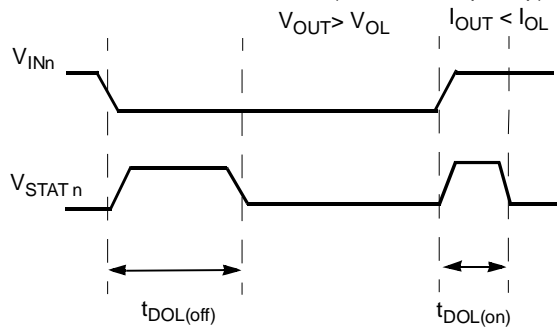

OVERTEMP STATUS TIMING

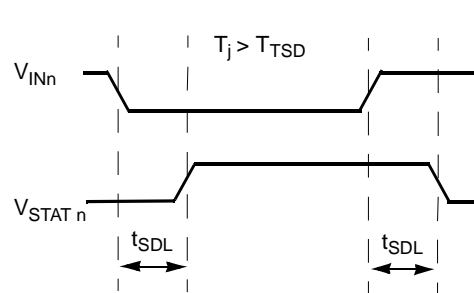

**Switching time Waveforms**

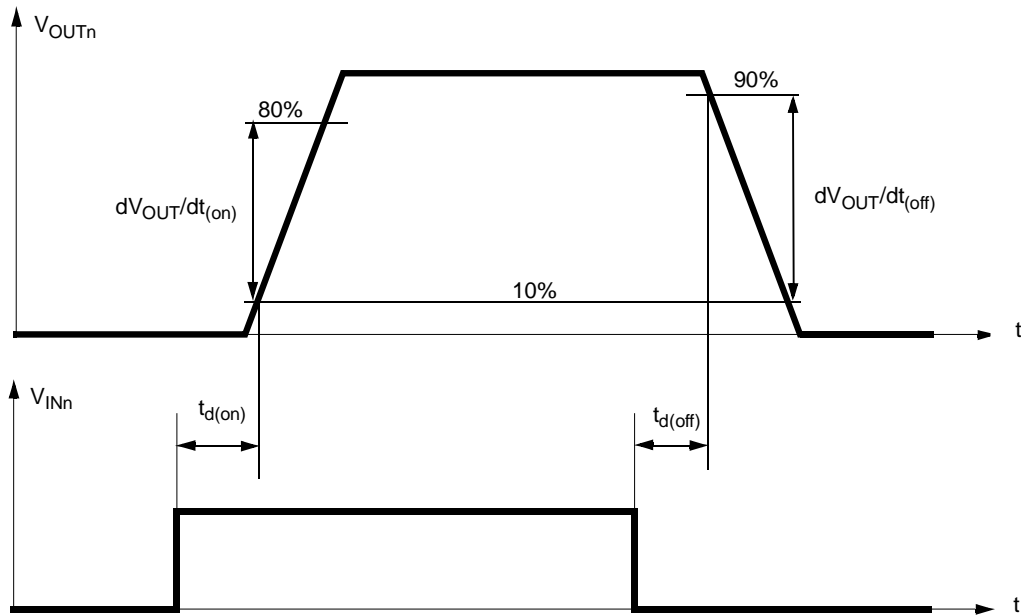

**TRUTH TABLE**

CONDITIONS	INPUT <sub>n</sub>	OUTPUT <sub>n</sub>	STATUS <sub>n</sub>
Normal Operation	L	L	H
	H	H	H
Current Limitation	L	L	H
	H	X	( $T_j < T_{TSD}$ ) H ( $T_j > T_{TSD}$ ) L
Overtemperature	L	L	H
	H	L	L
Undervoltage	L	L	X
	H	L	X
Overvoltage	L	L	H
	H	L	H
Output Voltage > $V_{OLn}$	L	H	L
	H	H	H
Output Current < $I_{OLn}$	L	L	H
	H	H	L

**ELECTRICAL TRANSIENT REQUIREMENTS ON V<sub>CC</sub> PIN**

ISO T/R 7637/1 Test Pulse	TEST LEVELS				Delays and Impedance
	I	II	III	IV	
1	-25 V	-50 V	-75 V	-100 V	2 ms 10 Ω
2	+25 V	+50 V	+75 V	+100 V	0.2 ms 10 Ω
3a	-25 V	-50 V	-100 V	-150 V	0.1 μs 50 Ω
3b	+25 V	+50 V	+75 V	+100 V	0.1 μs 50 Ω
4	-4 V	-5 V	-6 V	-7 V	100 ms, 0.01 Ω
5	+26.5 V	+46.5 V	+66.5 V	+86.5 V	400 ms, 2 Ω

ISO T/R 7637/1 Test Pulse	TEST LEVELS RESULTS			
	I	II	III	IV
1	C	C	C	C
2	C	C	C	C
3a	C	C	C	C
3b	C	C	C	C
4	C	C	C	C
5	C	E	E	E

CLASS	CONTENTS
<b>C</b>	All functions of the device are performed as designed after exposure to disturbance.
<b>E</b>	One or more functions of the device is not performed as designed after exposure and cannot be returned to proper operation without replacing the device.

Figure1: Waveforms

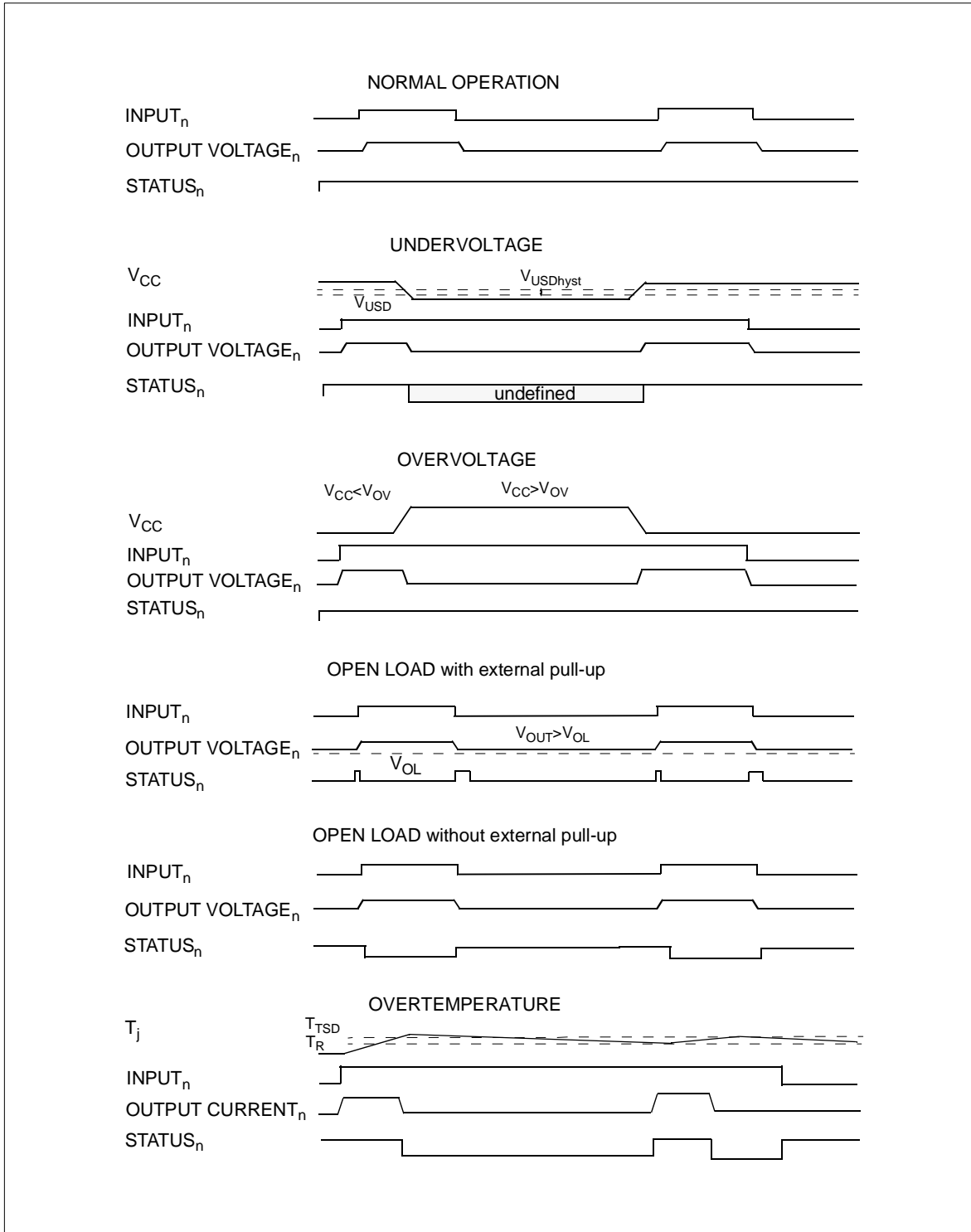

APPLICATION SCHEMATIC

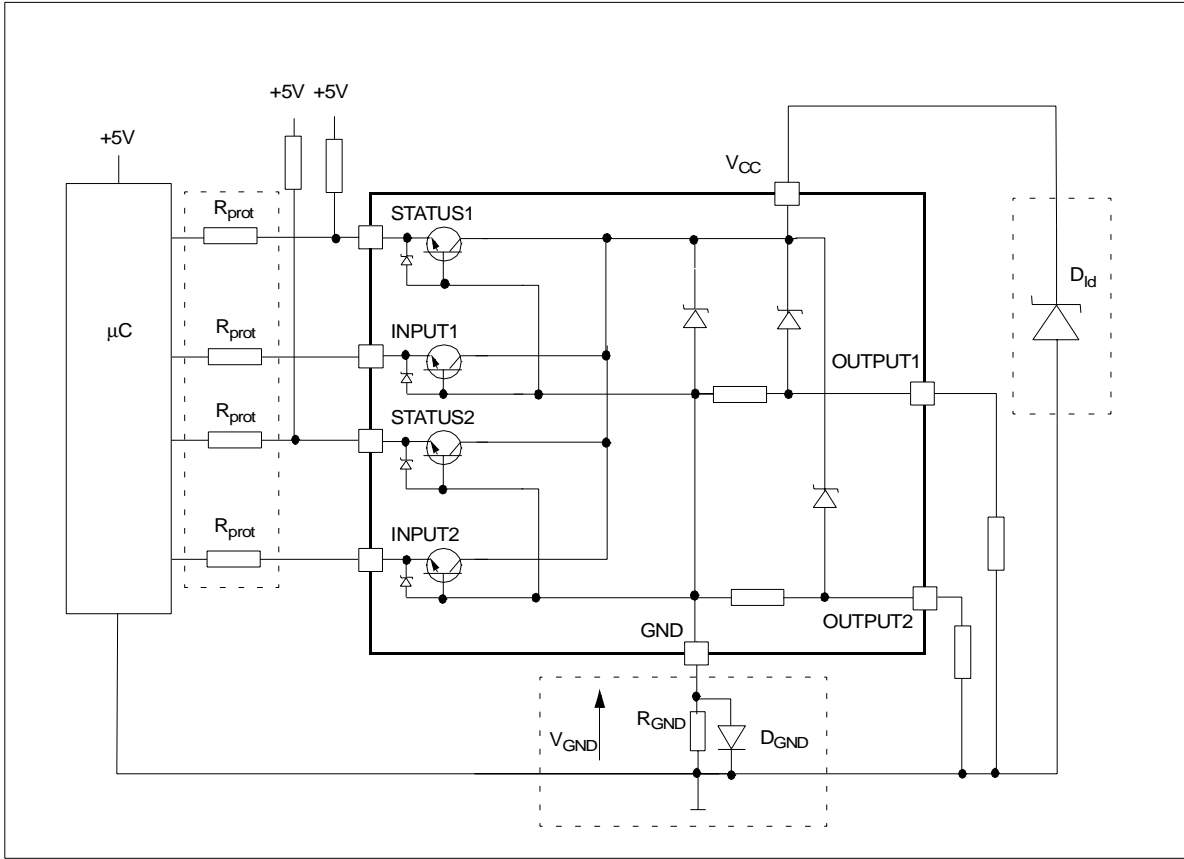

**GND PROTECTION NETWORK AGAINST REVERSE BATTERY**

**Solution 1:** Resistor in the ground line (R<sub>GND</sub> only). This can be used with any type of load.

The following is an indication on how to dimension the R<sub>GND</sub> resistor.

- 1)  $R_{GND} \leq 600mV / I_{S(on)max}$ .
- 2)  $R_{GND} \geq (-V_{CC}) / (-I_{GND})$

where -I<sub>GND</sub> is the DC reverse ground pin current and can be found in the absolute maximum rating section of the device's datasheet.

Power Dissipation in R<sub>GND</sub> (when V<sub>CC</sub><0: during reverse battery situations) is:

$$P_D = (-V_{CC})^2 / R_{GND}$$

This resistor can be shared amongst several different HSD. Please note that the value of this resistor should be calculated with formula (1) where I<sub>S(on)max</sub> becomes the sum of the maximum on-state currents of the different devices.

Please note that if the microprocessor ground is not common with the device ground then the R<sub>GND</sub> will produce a shift (I<sub>S(on)max</sub> \* R<sub>GND</sub>) in the input thresholds and the status output values. This shift will vary

depending on how many devices are ON in the case of several high side drivers sharing the same R<sub>GND</sub>.

If the calculated power dissipation leads to a large resistor or several devices have to share the same resistor then the ST suggests to utilize Solution 2 (see below).

**Solution 2:** A diode (D<sub>GND</sub>) in the ground line.

A resistor (R<sub>GND</sub>=1kΩ) should be inserted in parallel to D<sub>GND</sub> if the device will be driving an inductive load.

This small signal diode can be safely shared amongst several different HSD. Also in this case, the presence of the ground network will produce a shift (≈600mV) in the input threshold and the status output values if the microprocessor ground is not common with the device ground. This shift will not vary if more than one HSD shares the same diode/resistor network.

Series resistor in INPUT and STATUS lines are also required to prevent that, during battery voltage transient, the current exceeds the Absolute Maximum Rating.

Safest configuration for unused INPUT and STATUS pin is to leave them unconnected.

**LOAD DUMP PROTECTION**

$D_{id}$  is necessary (Voltage Transient Suppressor) if the load dump peak voltage exceeds  $V_{CC}$  max DC rating. The same applies if the device will be subject to transients on the  $V_{CC}$  line that are greater than the ones shown in the ISO T/R 7637/1 table.

**μC I/Os PROTECTION:**

If a ground protection network is used and negative transient are present on the  $V_{CC}$  line, the control pins will be pulled negative. ST suggests to insert a resistor ( $R_{prot}$ ) in line to prevent the μC I/Os pins to latch-up.

The value of these resistors is a compromise between the leakage current of μC and the current required by the HSD I/Os (Input levels compatibility) with the latch-up limit of μC I/Os.

$$-V_{CCpeak}/I_{latchup} \leq R_{prot} \leq (V_{OH\mu C} - V_{IH} - V_{GND}) / I_{IHmax}$$

Calculation example:

For  $V_{CCpeak} = -100V$  and  $I_{latchup} \geq 20mA$ ;  $V_{OH\mu C} \geq 4.5V$   
 $5k\Omega \leq R_{prot} \leq 65k\Omega$ .

Recommended  $R_{prot}$  value is 10kΩ.

**OPEN LOAD DETECTION IN OFF STATE**

Off state open load detection requires an external pull-up resistor ( $R_{PU}$ ) connected between OUTPUT pin and a positive supply voltage ( $V_{PU}$ ) like the +5V line used to supply the microprocessor.

The external resistor has to be selected according to the following requirements:

- 1) no false open load indication when load is connected: in this case we have to avoid  $V_{OUT}$  to be higher than  $V_{OLmin}$ ; this results in the following condition  
 $V_{OUT} = (V_{PU} / (R_L + R_{PU})) R_L < V_{OLmin}$ .
- 2) no misdetection when load is disconnected: in this case the  $V_{OUT}$  has to be higher than  $V_{OLmax}$ ; this results in the following condition  $R_{PU} < (V_{PU} - V_{OLmax}) / I_{L(off2)}$ .

Because  $I_{S(OFF)}$  may significantly increase if  $V_{out}$  is pulled high (up to several mA), the pull-up resistor  $R_{PU}$  should be connected to a supply that is switched OFF when the module is in standby.

The values of  $V_{OLmin}$ ,  $V_{OLmax}$  and  $I_{L(off2)}$  are available in the Electrical Characteristics section.

**Open Load detection in off state**

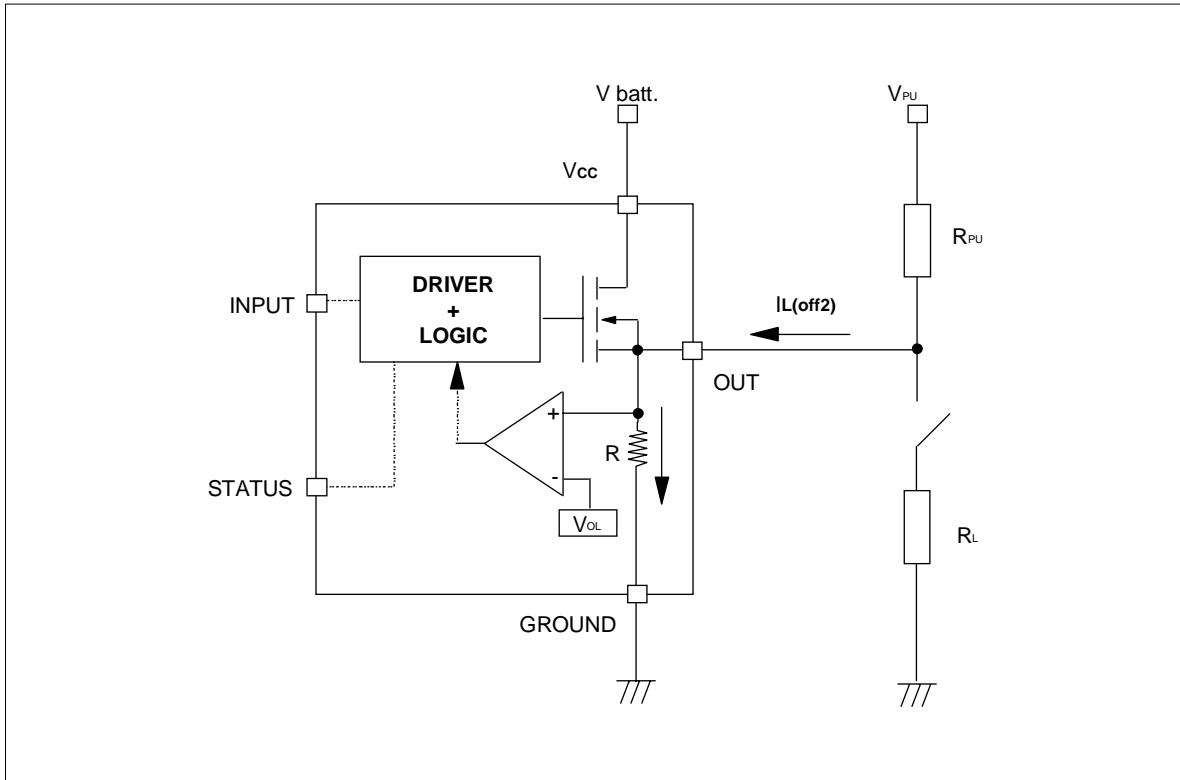

**VND810PEP**

---

Off State Output Current

High Level Input Current

**TBD**

**TBD**

Input Clamp Voltage

Status Leakage Current

**TBD**

**TBD**

Status Low Output Voltage

Status Clamp Voltage

**TBD**

**TBD**



On State Resistance Vs  $T_{case}$

On State Resistance Vs  $V_{CC}$

TBD

TBD

Openload On State Detection Threshold

Input High Level

TBD

TBD

Input Low Level

Input Hysteresis Voltage

TBD

TBD

**VND810PEP**

---

Overvoltage Shutdown

Openload Off State Voltage Detection Threshold

**TBD**

**TBD**

Turn-on Voltage Slope

Turn-off Voltage Slope

**TBD**

**TBD**

$I_{LIM}$  Vs  $T_{case}$

**TBD**



## PSSO-12™ MECHANICAL DATA

DIM.	mm.		
	MIN.	TYP	MAX.
A	1.250		1.620
A1	0.000		0.100
A2	1.100		1.650
B	0.230		0.410
C	0.190		0.250
D	4.800		5.000
E	3.800		4.000
e		0.800	
H	5.800		6.200
h	0.250		0.500
L	0.400		1.270
k	0°		8°
X	1.900		2.500
Y	3.600		4.200
ddd			0.100

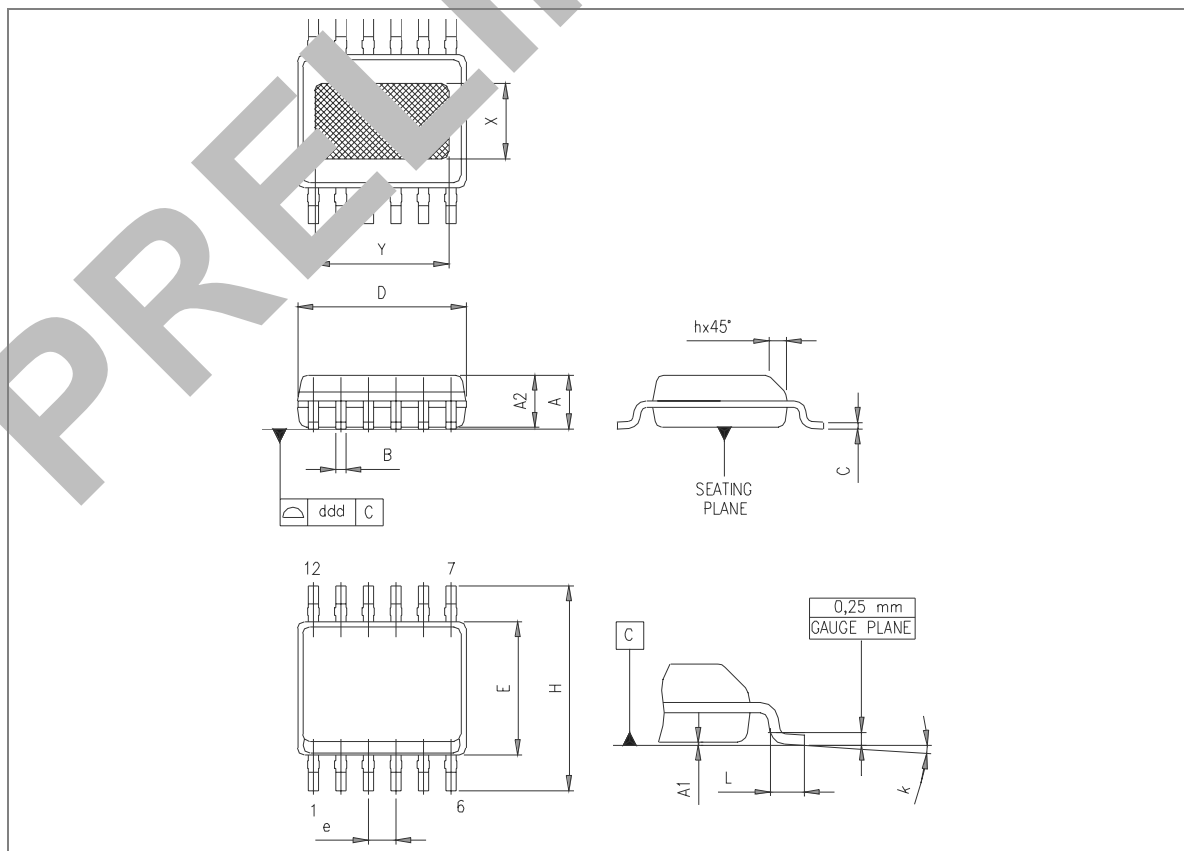

Information furnished is believed to be accurate and reliable. However, STMicroelectronics assumes no responsibility for the consequences of use of such information nor for any infringement of patents or other rights of third parties which may result from its use. No license is granted by implication or otherwise under any patent or patent rights of STMicroelectronics. Specifications mentioned in this publication are subject to change without notice. This publication supersedes and replaces all information previously supplied. STMicroelectronics products are not authorized for use as critical components in life support devices or systems without express written approval of STMicroelectronics.  
The ST logo is a trademark of STMicroelectronics

© 2003 STMicroelectronics - Printed in ITALY- All Rights Reserved.

STMicroelectronics GROUP OF COMPANIES

Australia - Brazil - Canada - China - Finland - France - Germany - Hong Kong - India - Israel - Italy - Japan - Malaysia -  
Malta - Morocco - Singapore - Spain - Sweden - Switzerland - United Kingdom - U.S.A.

<http://www.st.com>