



# VNQ05XSP16

## QUAD CHANNEL HIGH SIDE SOLID STATE RELAY

TYPE	R <sub>ON</sub> (*)	I <sub>OUT</sub>	V <sub>CC</sub>
VNQ05XSP16	110mΩ	5A (*)	36 V

(\*) Per each channel

- OUTPUT CURRENT (CONTINUOUS): 5A
- CMOS COMPATIBLE INPUTS
- MULTIPLEXED PROPORTIONAL LOAD CURRENT SENSE
- UNDERVOLTAGE & OVERVOLTAGE SHUT-DOWN
- OVERVOLTAGE CLAMP
- THERMAL SHUT DOWN
- CURRENT LIMITATION
- VERY LOW STAND-BY POWER DISSIPATION
- PROTECTION AGAINST:
  - LOSS OF GROUND & LOSS OF V<sub>CC</sub>
- REVERSE BATTERY PROTECTION (\*\*)

### DESCRIPTION

The VNQ05XSP16 is a monolithic device designed in STMicroelectronics VIPower M0-3

### ABSOLUTE MAXIMUM RATING

Symbol	Parameter	Value	Unit
V <sub>CC</sub>	Supply voltage (continuous)	41	V
-V <sub>CC</sub>	Reverse supply voltage (continuous)	-0.3	V
I <sub>OUT</sub>	Output current (continuous), for each channel	Internally limited	A
I <sub>R</sub>	Reverse output current (continuous), for each channel	-5	A
I <sub>IN</sub>	Input current (IN1,IN2,IN3,IN4,SELA,SELB,SENSEENABLE)	+/- 10	mA
V <sub>CSENSE</sub>	Current sense maximum voltage	-3 +15	V V
I <sub>GND</sub>	Ground current at T <sub>case</sub> ≤25°C (continuous)	-200	mA
V <sub>ESD</sub>	Electrostatic Discharge (Human Body Model: R=1.5Ω; C=100pF)		
	- INPUT	4000	V
	- CURRENT SENSE	2000	V
	- OUTPUT	5000	V
	- V <sub>CC</sub>	5000	V
P <sub>tot</sub>	Power dissipation at T <sub>case</sub> =25°C	78	W
E <sub>MAX</sub>	Maximum Switching Energy (L=1.72mH; R <sub>L</sub> =0Ω; V <sub>bat</sub> =13.5V; T <sub>jstart</sub> =150°C; I <sub>L</sub> =7.5A)	76	mJ
T <sub>j</sub>	Junction operating temperature	Internally limited	°C
T <sub>c</sub>	Case Operating Temperature	- 40 to 150	°C
T <sub>STG</sub>	Storage temperature	-55 to 150	°C

(\*\*) See application schematic at page 9

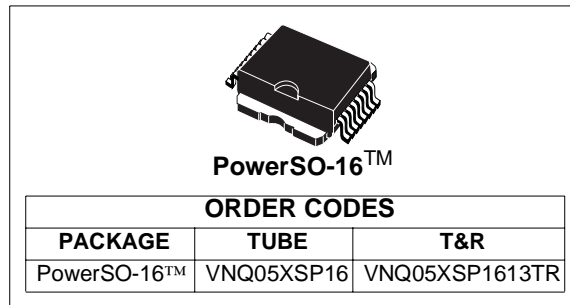

Technology. It is intended for driving any type of multiple loads with one side connected to ground. Active V<sub>CC</sub> pin voltage clamp protects the device against low energy spikes (see ISO7637 transient compatibility table). This device has four independent channels and one multiplexed analog sense output which deliver a current proportional to the selected output current. SenseEnable pin allows to connect any number of VNQ05XSP16 on the same Current Sense line. Active current limitation combined with thermal shut-down and automatic restart protect the device against overload. Device automatically turns off in case of ground pin disconnection.

BLOCK DIAGRAM

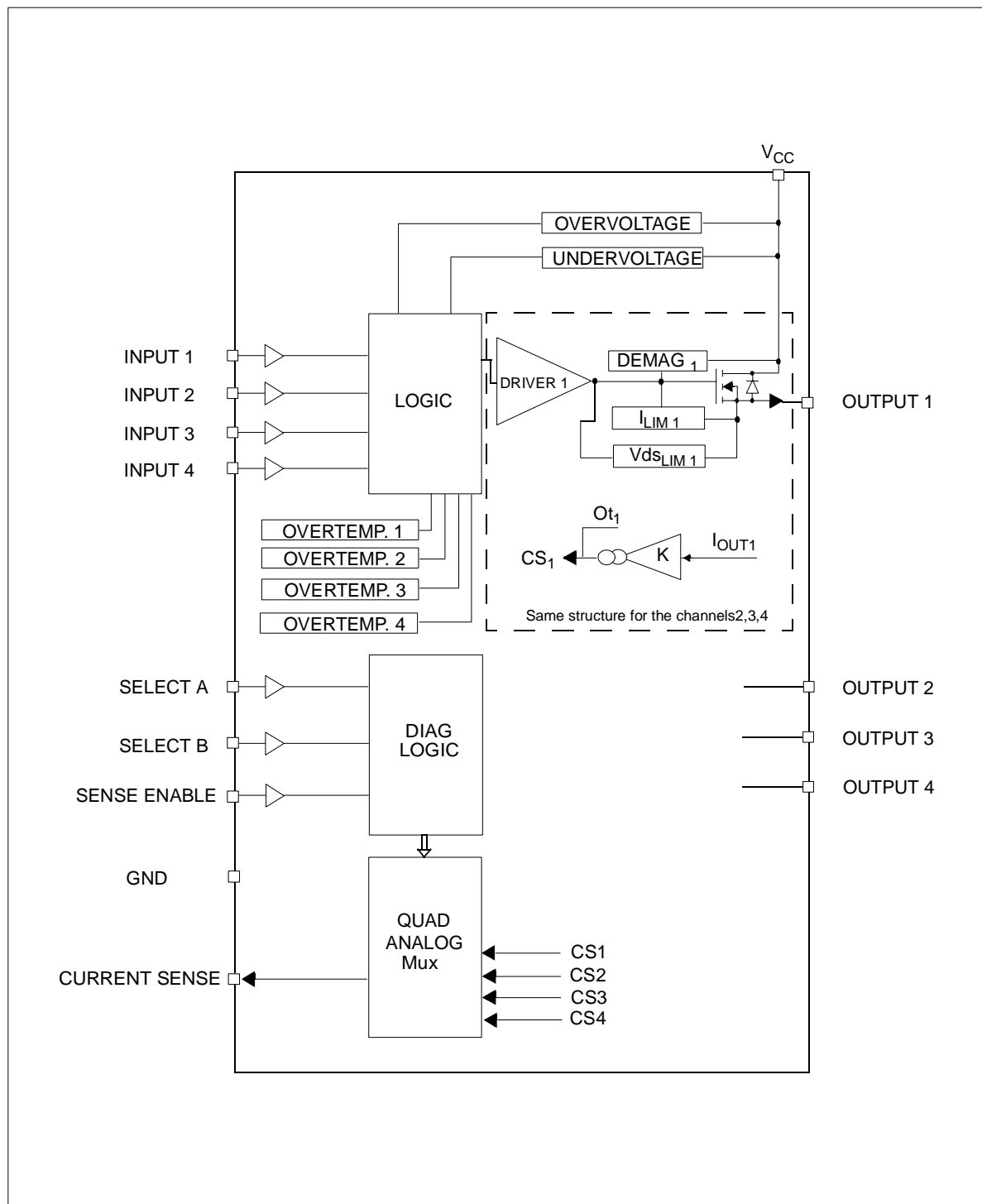

**CURRENT AND VOLTAGE CONVENTIONS**

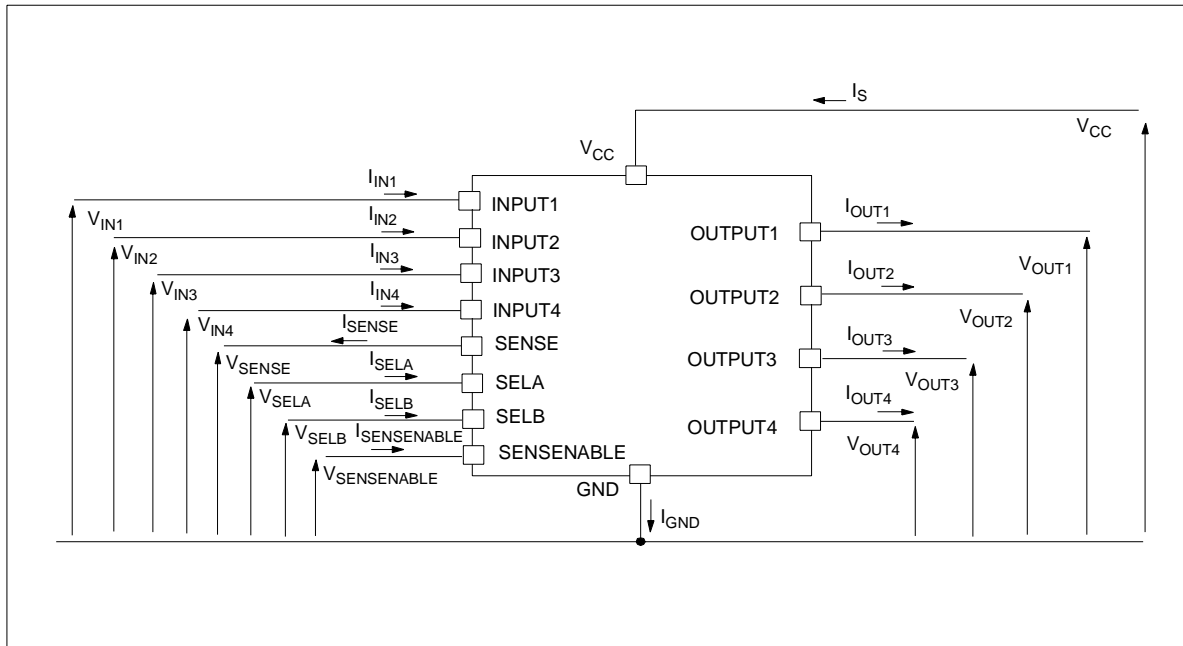

**CONNECTION DIAGRAM (TOP VIEW)**

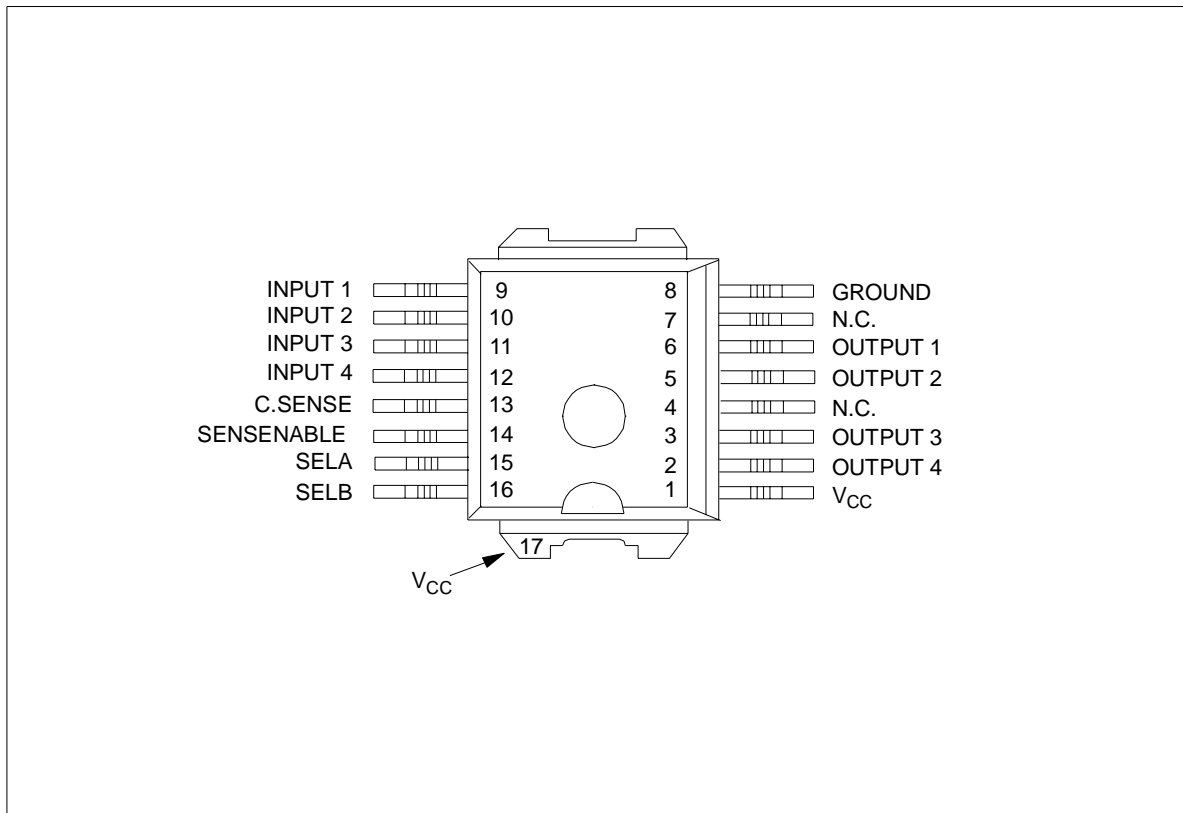

## VNQ05XSP16

### THERMAL DATA

Symbol	Parameter	Value	Unit
R <sub>thj-case</sub>	Thermal resistance junction-case (MAX)	1.6	°C/W
R <sub>thj-amb</sub>	Thermal resistance junction-ambient (MAX)	51.6 (*)	°C/W

(\*) When mounted on FR4 printed circuit board with 0.5 cm<sup>2</sup> of copper area (at least 35 μm thick) connected to all V<sub>CC</sub> pins

### ELECTRICAL CHARACTERISTICS (8V < V<sub>CC</sub> < 36V; -40°C < T<sub>j</sub> < 150°C; unless otherwise specified) (Per each channel) POWER

Symbol	Parameter	Test Conditions	Min	Typ	Max	Unit
V <sub>CC</sub>	Operating supply voltage		5.5	13	36	V
V <sub>USD</sub>	Under voltage shut down		3	4	5.5	V
V <sub>OV</sub>	Overvoltage shut down		36			V
R <sub>ON</sub>	On state resistance	I <sub>OUT1,2,3,4</sub> =1A; T <sub>j</sub> =25°C I <sub>OUT1,2,3,4</sub> =1A; T <sub>j</sub> =150°C I <sub>OUT1,2,3,4</sub> =0.5A; V <sub>CC</sub> =6V			110 220 330	mΩ
V <sub>clamp</sub>	Clamp Voltage	I <sub>CC</sub> =20mA (See note 1)	41	48	55	V
I <sub>S</sub>	Supply current	Off state; Inputs=n.c.; V <sub>CC</sub> =13V On state; V <sub>IN</sub> =5V; V <sub>CC</sub> =13V; I <sub>OUT</sub> =0A; R <sub>SENSE</sub> =3.9kΩ			80 10	μA mA
I <sub>L(off1)</sub>	Off State Output Current	V <sub>IN</sub> =V <sub>OUT</sub> =0V	0		50	μA
I <sub>L(off2)</sub>	Off State Output Current	V <sub>IN</sub> =0V; V <sub>OUT</sub> =3.5V	-75		0	μA
I <sub>L(off3)</sub>	Off State Output Current	V <sub>IN</sub> =V <sub>OUT</sub> =0V; V <sub>CC</sub> =13V; T <sub>j</sub> =125°C			5	μA
I <sub>L(off4)</sub>	Off State Output Current	V <sub>IN</sub> =V <sub>OUT</sub> =0V; V <sub>CC</sub> =13V; T <sub>j</sub> =25°C			3	μA

### SWITCHING (V<sub>CC</sub>=13V)

Symbol	Parameter	Test Conditions	Min	Typ	Max	Unit
t <sub>d(on)</sub>	Turn-on delay time	R <sub>L</sub> =2.6Ω channels 1,2,3,4 (see figure 2)		40		μs
t <sub>d(off)</sub>	Turn-off delay time	R <sub>L</sub> =2.6Ω channels 1,2,3,4 (see figure 2)		40		μs
(dV <sub>OUT</sub> /dt) <sub>on</sub>	Turn-on voltage slope	R <sub>L</sub> =2.6Ω channels 1,2,3,4 (see figure 2)		See relative diagram		V/μs
(dV <sub>OUT</sub> /dt) <sub>off</sub>	Turn-off voltage slope	R <sub>L</sub> =2.6Ω channels 1,2,3,4 (see figure 2)		See relative diagram		V/μs

### PROTECTIONS

Symbol	Parameter	Test Conditions	Min	Typ	Max	Unit
I <sub>lim</sub>	DC short circuit current	V <sub>CC</sub> =13V 5.5V < V <sub>CC</sub> < 36V	5	7.5	10 10	A A
T <sub>TSD</sub>	Thermal shut down temperature		150	175	200	°C
T <sub>R</sub>	Thermal reset temperature		135			°C
T <sub>HYST</sub>	Thermal hysteresis		7	15		°C
V <sub>demag</sub>	Turn-off output voltage clamp	I <sub>OUT</sub> =2A; L=6mH	V <sub>CC</sub> -41	V <sub>CC</sub> -48	V <sub>CC</sub> -55	V
V <sub>ON</sub>	Output voltage drop limitation	I <sub>OUT</sub> =0.1A T <sub>j</sub> =-40°C...+150°C		50		mV

Note 1: V<sub>clamp</sub> and V<sub>OV</sub> are correlated. Typical difference is 5V.

CURRENT SENSE ( $9V < V_{CC} < 16V$ )

Symbol	Parameter	Test Conditions	Min	Typ	Max	Unit
$K_1$	$I_{OUT}/I_{SENSE}$	$I_{OUT1,2} = 0.1A$ ; $V_{SENSE} = 0.5V$ $T_j = -40...+150^{\circ}C$	800	1000	1200	
$dK_1/K_1$	Current Sense Ratio Drift	$I_{OUT} = 0.1A$ ; $V_{SENSE} = 0.5V$ ; $T_j = -40^{\circ}C...+150^{\circ}C$	-10		+10	%
$K_2$	$I_{OUT}/I_{SENSE}$	$I_{OUT1,2} = 1.0A$ , $V_{SENSE} = 4V$ $T_j = -40...+150^{\circ}C$	800	1000	1200	
$dK_2/K_2$	Current Sense Ratio Drift	$I_{OUT} = 1.0A$ ; $V_{SENSE} = 4V$ ; $T_j = -40^{\circ}C...+150^{\circ}C$	-8		+8	%
$K_3$	$I_{OUT}/I_{SENSE}$	$I_{OUT1,2} = 2.0A$ , $V_{SENSE} = 4V$ $T_j = -40...+150^{\circ}C$	850	1000	1150	
$dK_3/K_3$	Current Sense Ratio Drift	$I_{OUT} = 2.0A$ ; $V_{SENSE} = 4V$ ; $T_j = -40^{\circ}C...+150^{\circ}C$	-6		+6	%
$I_{SENSE0}$	Analog Sense Leakage Current	$V_{CC} = 6...16V$ ; $I_{OUT} = 0A$ ; $V_{SENSE} = 0V$ ; $T_j = -40^{\circ}C...+150^{\circ}C$	0		10	$\mu A$
$V_{SENSE1,2,3,4}$	Max analog sense output voltage	$V_{CC} = 5.5V$ , $I_{OUT1,2,3,4} = 1.0A$ $R_{SENSE} = 10k\Omega$ $V_{CC} > 8V$ , $I_{OUT1,2,3,4} = 2.0A$ $R_{SENSE} = 10k\Omega$	2			V
$V_{SENSEH}$	Analog sense output voltage in overtemperature condition	$V_{CC} = 13V$ ; $R_{SENSE} = 3.9k\Omega$		5.5		V
$R_{VSENSEH}$	Analog sense output impedance in overtemperature condition	$V_{CC} = 13V$ ; $T_j > T_{TSD}$ ; All Channels Open		400		$\Omega$
$t_{DSENSE}$	Current sense delay	$V_{CC} = 13V$ ; $R_{SENSE} = 3.9k\Omega$ (see note 2)		300	500	$\mu s$

## LOGIC CHARACTERISTICS (Inputs, Sela&amp;b, Sensenable)

Symbol	Parameter	Test Conditions	Min	Typ	Max	Unit
$V_{IL}$	Input low level voltage				1.25	V
$V_{IH}$	Input high level voltage		3.25			V
$V_{I(hyst)}$	Input hysteresis voltage		0.5			V
$I_{IL}$	Low level input current	$V_{IN} = 1.25V$	1			$\mu A$
$I_{IN}$	High level input current	$V_{IN} = 3.25V$			10	$\mu A$
$V_{ICL}$	Input clamp voltage	$I_{IN} = 1mA$ $I_{IN} = -1mA$	6	6.8 -0.7	8	V V

Note 2: current sense signal delay after positive input slope.

Note: Sense pin doesn't have to be left floating.

**TRUTH TABLE**

CONDITIONS	INPUT	OUTPUT	SENSE
Normal operation	L	L	0
	H	H	Nominal
Overtemperature	L	L	0
	H	L	$V_{SENSEH}$
Undervoltage	L	L	0
	H	L	0
Overvoltage	L	L	0
	H	L	0
Short circuit to GND	L	L	0
	H	L	$(T_j < T_{TSD})$ 0
	H	L	$(T_j > T_{TSD})$ $V_{SENSEH}$
Short circuit to $V_{CC}$	L	H	0
	H	H	< Nominal
Negative output voltage clamp	L	L	0

**TRUTH TABLE**

SENSEABLE	SELB	SELA	SENSE
L	X	X	High Impedance
H	L	L	$I_{SENSE} = I_{OUT1}/K$
H	L	H	$I_{SENSE} = I_{OUT2}/K$
H	H	L	$I_{SENSE} = I_{OUT3}/K$
H	H	H	$I_{SENSE} = I_{OUT4}/K$

Figure 1:  $I_{OUT}/I_{SENSE}$  versus  $I_{OUT}$

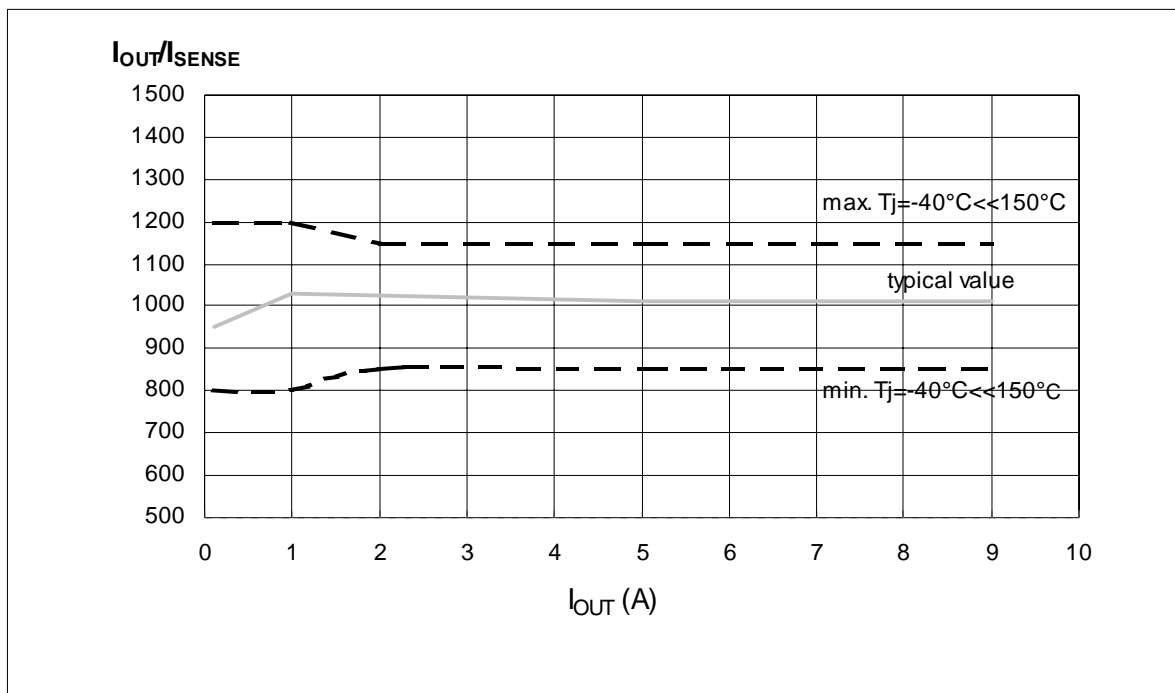

**ELECTRICAL TRANSIENT REQUIREMENTS**

ISO T/R 7637/1 Test Pulse	Test Levels I	Test Levels II	Test Levels III	Test Levels IV	Test Levels Delays and Impedance
1	-25V	-50V	-75V	-100V	2ms, 10Ω
2	+25V	+50V	+75V	+100V	0.2ms, 10Ω
3a	-25V	-50V	-100V	-150V	0.1μs, 50Ω
3b	+25V	+50V	+75V	+100V	0.1μs, 50Ω
4	-4V	-5V	-6V	-7V	10ms, 0.01Ω
5	+26.5V	+46.5V	+66.5V	+86.5V	400ms, 2Ω

ISO T/R 7637/1 Test Pulse	Test Levels Result I	Test Levels Result II	Test Levels Result III	Test Levels Result IV
1	C	C	C	C
2	C	C	C	C
3a	C	C	C	C
3b	C	C	C	C
4	C	C	C	C
5	C	E	E	E

Class	Contents
C	All functions of the device are performed as designed after exposure to disturbance.
E	One or more functions of the device is not performed as designed after exposure and cannot be returned to proper operation without replacing the device.

**Figure 2: Switching Characteristics (Resistive load  $R_L=1.3\Omega$ )**

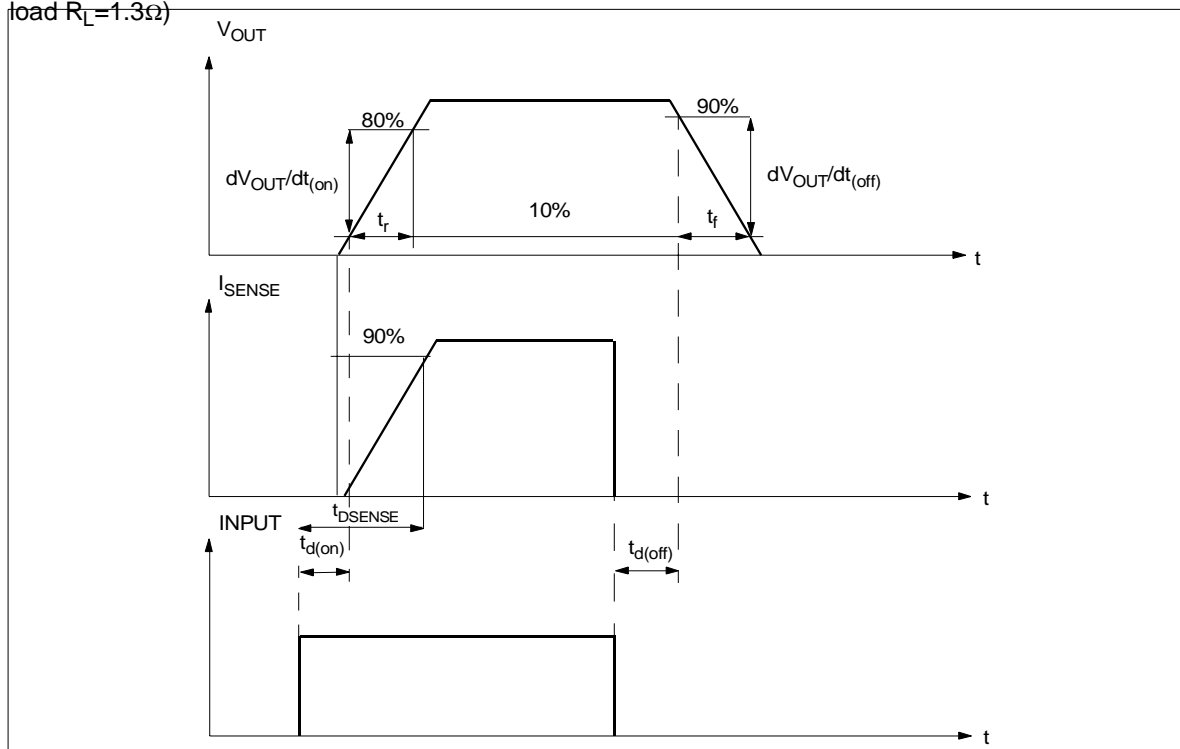
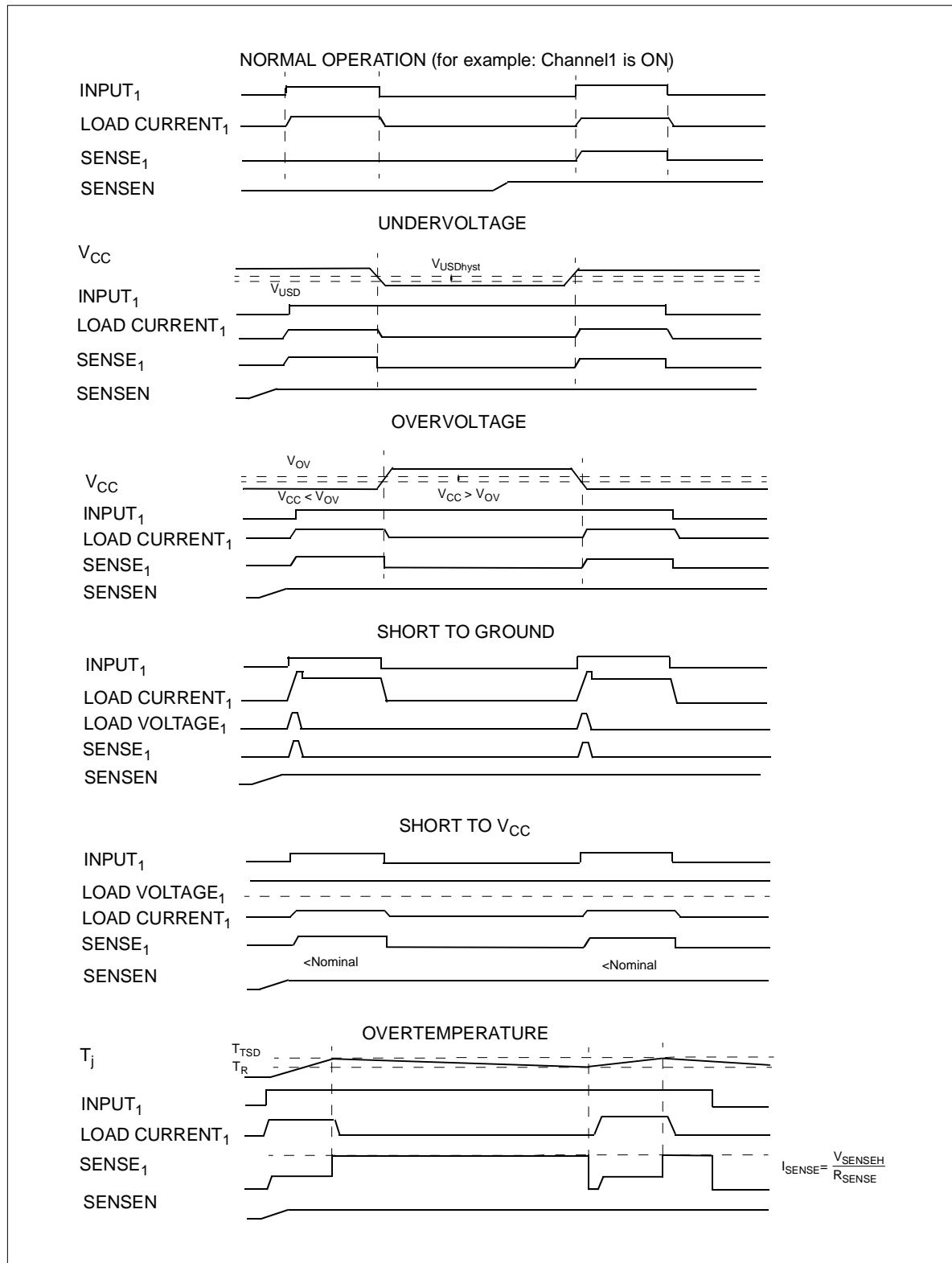
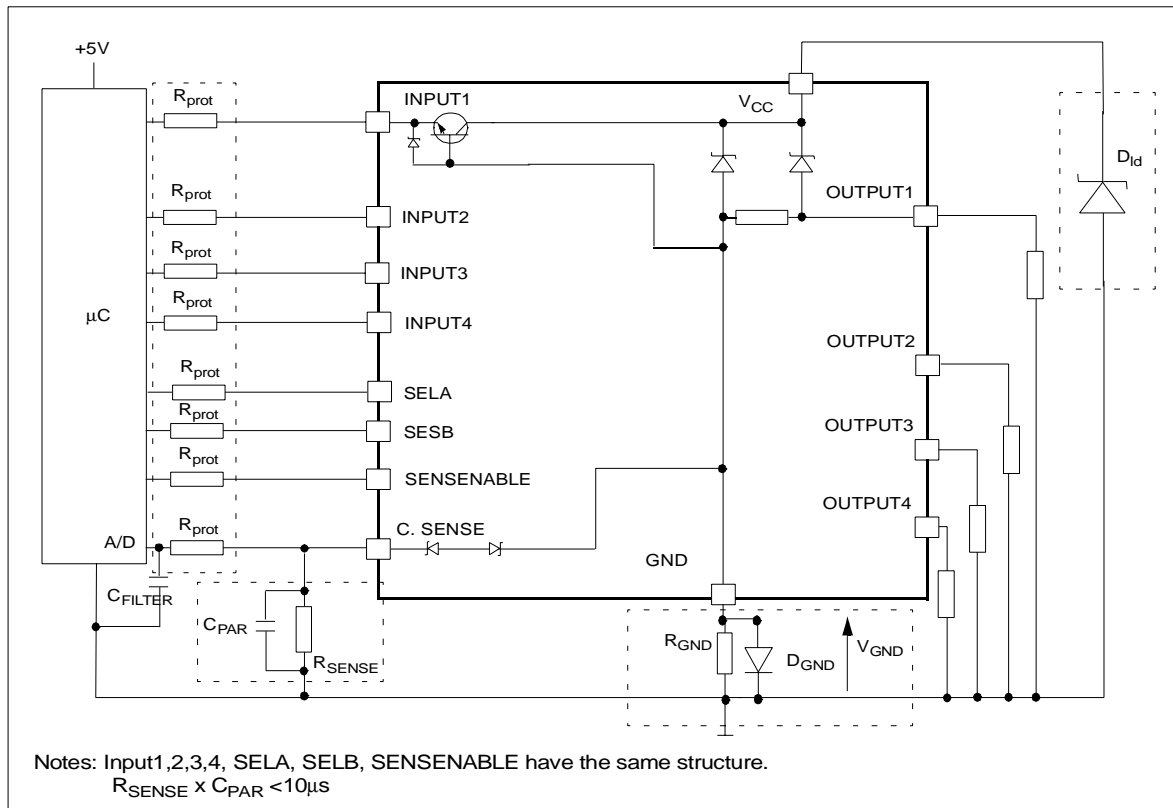

Figure 3: Waveforms



## APPLICATION SCHEMATIC



## GND PROTECTION NETWORK AGAINST REVERSE BATTERY

**Solution 1:** Resistor in the ground line ( $R_{GND}$  only). This can be used with any type of load.

The following is an indication on how to dimension the  $R_{GND}$  resistor.

- 1)  $R_{GND} \leq 600mV / (I_{S(on)max})$ .
- 2)  $R_{GND} \geq (-V_{CC}) / (-I_{GND})$

where  $-I_{GND}$  is the DC reverse ground pin current and can be found in the absolute maximum rating section of the device's datasheet.

Power Dissipation in  $R_{GND}$  (when  $V_{CC} < 0$ : during reverse battery situations) is:

$$P_D = (-V_{CC})^2 / R_{GND}$$

This resistor can be shared amongst several different HSD. Please note that the value of this resistor should be calculated with formula (1) where  $I_{S(on)max}$  becomes the sum of the maximum on-state currents of the different devices.

Please note that if the microprocessor ground is not common with the device ground then the  $R_{GND}$  will produce a shift ( $I_{S(on)max} * R_{GND}$ ) in the input thresholds and the status output values. This shift will vary depending on how many devices are ON in the case of several high side drivers sharing the same  $R_{GND}$ .

If the calculated power dissipation leads to a large resistor or several devices have to share the same resistor then the ST suggests to utilize Solution 2 (see below).

**Solution 2:** A diode ( $D_{GND}$ ) in the ground line.

A resistor ( $R_{GND} = 1k\Omega$ ) should be inserted in parallel to  $D_{GND}$  if the device will be driving an inductive load.

This small signal diode can be safely shared amongst several different HSD. Also in this case, the presence of the ground network will produce a shift ( $\approx 600mV$ ) in the input threshold and the status output values if the microprocessor ground is not common with the device ground. This shift will not vary if more than one HSD shares the same diode/resistor network.

## LOAD DUMP PROTECTION

$D_{Id}$  is necessary (Voltage Transient Suppressor) if the load dump peak voltage exceeds  $V_{CC}$  max DC rating. The same applies if the device will be subject to transients on the  $V_{CC}$  line that are greater than the ones shown in the ISO T/R 7637/1 table.

 $\mu C$  I/Os PROTECTION:

If a ground protection network is used and negative transients are present on the  $V_{CC}$  line, the control pins will be pulled negative. ST suggests to insert a resistor ( $R_{prot}$ ) in line to prevent the  $\mu C$  I/Os pins to latch-up.

The value of these resistors is a compromise between the leakage current of  $\mu C$  and the current required by the HSD I/Os (Input levels compatibility) with the latch-up limit of  $\mu C$  I/Os.

$$-V_{CCpeak} / I_{latchup} \leq R_{prot} \leq (V_{OH\mu C} - V_{IH} - V_{GND}) / I_{IHmax}$$

For  $V_{CCpeak} = -100V$  and  $I_{latchup} \geq 20mA$ ;  $V_{OH\mu C} \geq 4.5V$   
 $5k\Omega \leq R_{prot} \leq 65k\Omega$ .

Recommended  $R_{prot}$  value is 10k $\Omega$ .

Off State Output Current

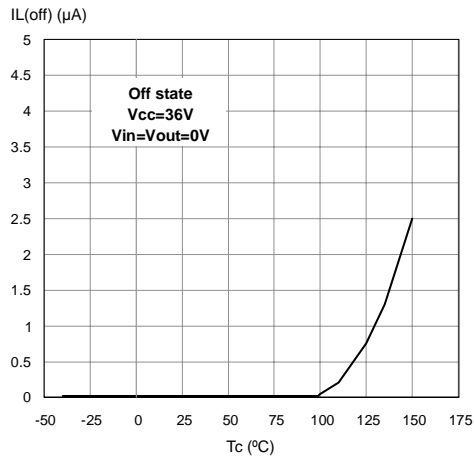

High Level Input Current

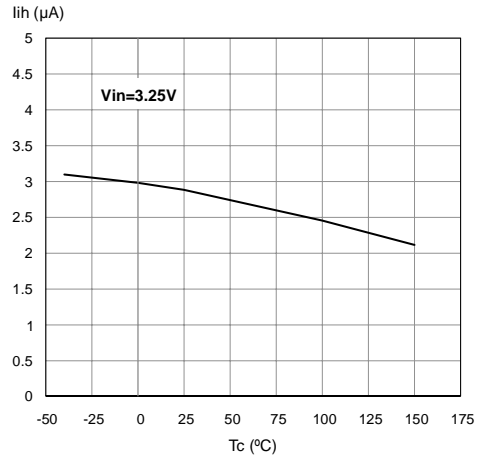

Input Clamp Voltage

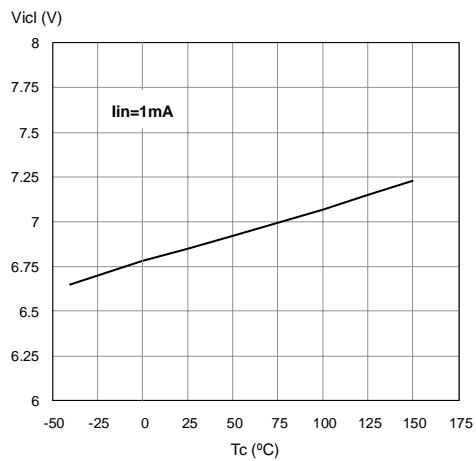

Input High Level

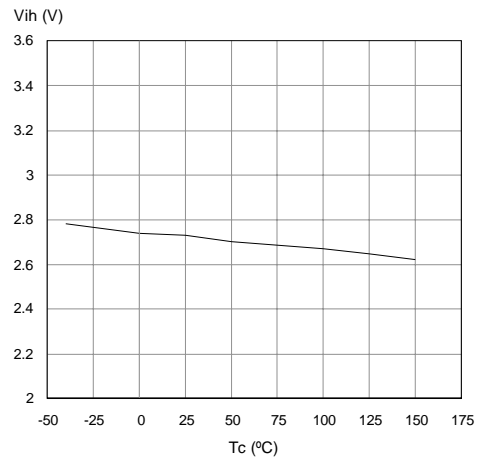

Overvoltage Shutdown

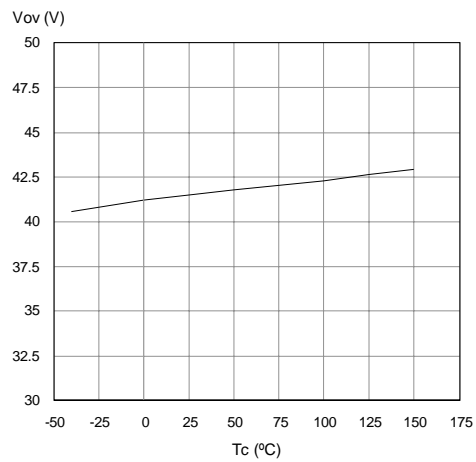

I<sub>LIM</sub> Vs T<sub>case</sub>

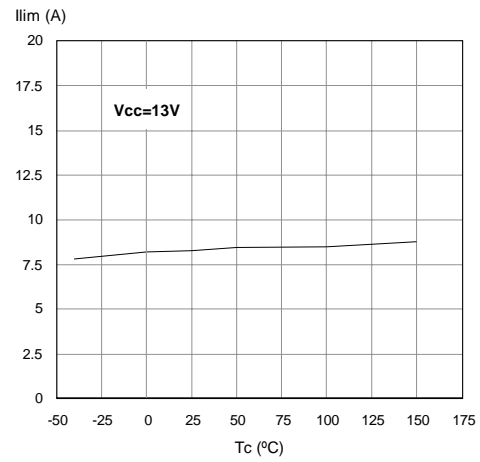

Turn-on Voltage Slope

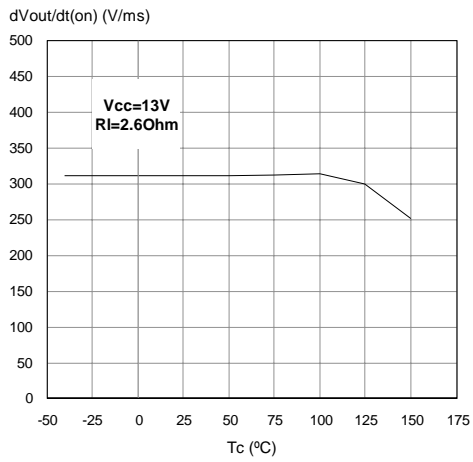

Turn-off Voltage Slope

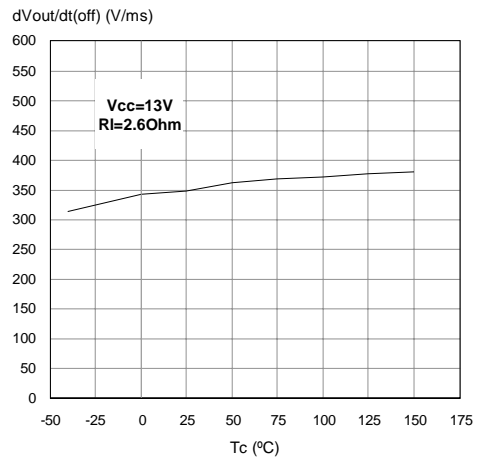

On State Resistance Vs  $T_{case}$

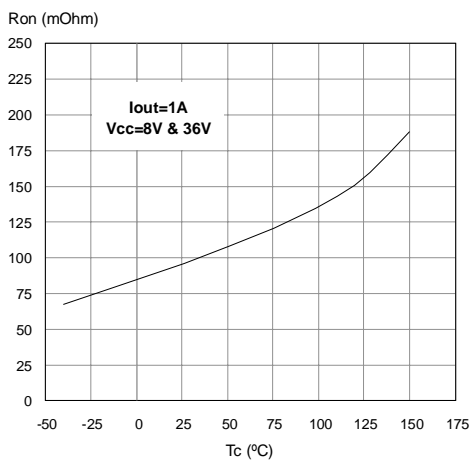

On State Resistance Vs  $V_{CC}$

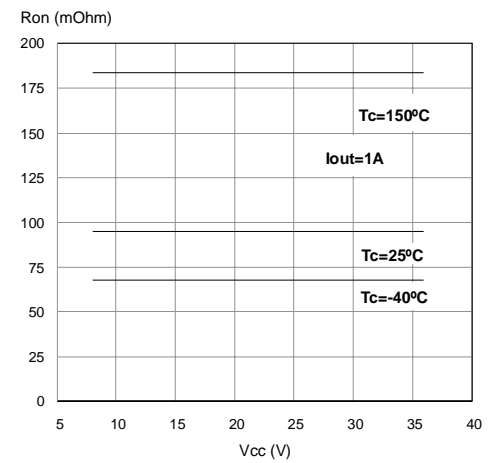

Maximum turn off current versus load inductance

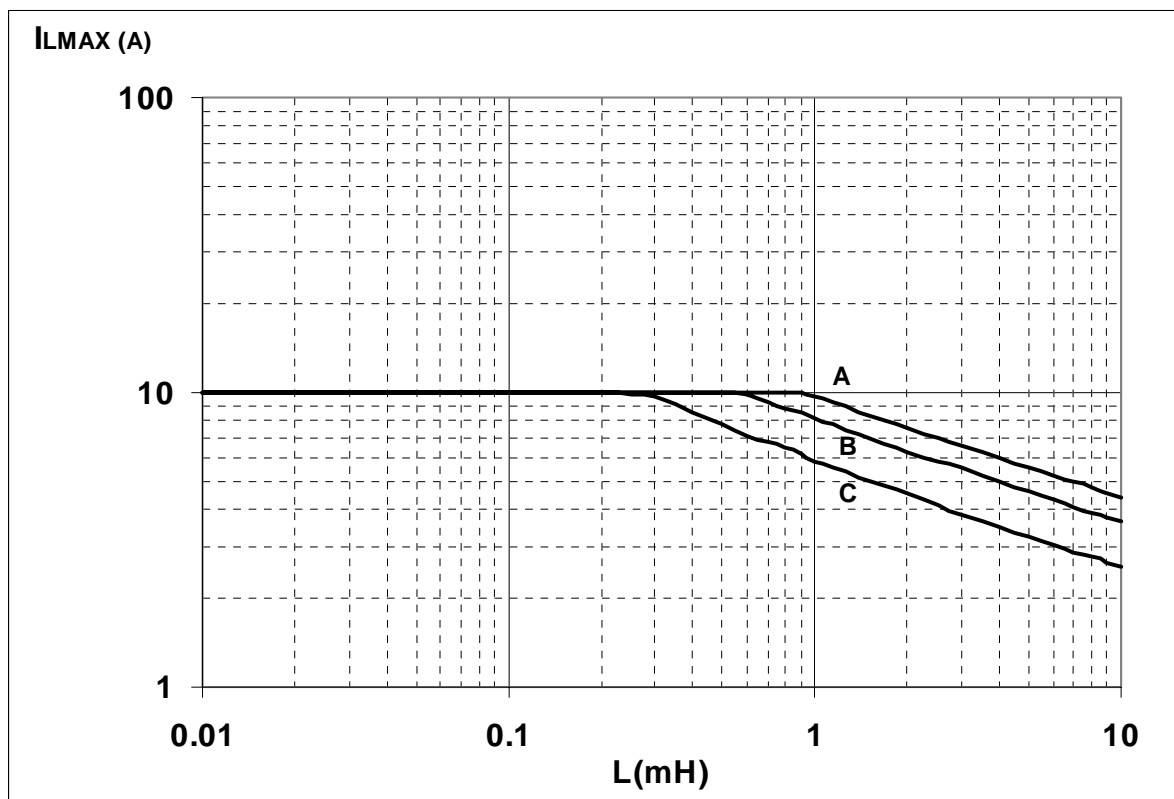

- A = Single Pulse at  $T_{Jstart}=150^{\circ}C$
- B= Repetitive pulse at  $T_{Jstart}=100^{\circ}C$
- C= Repetitive Pulse at  $T_{Jstart}=125^{\circ}C$

Conditions:

$V_{CC}=13.5V$

Values are generated with  $R_L=0\Omega$

In case of repetitive pulses,  $T_{Jstart}$  (at beginning of each demagnetization) of every pulse must not exceed the temperature specified above for curves B and C.

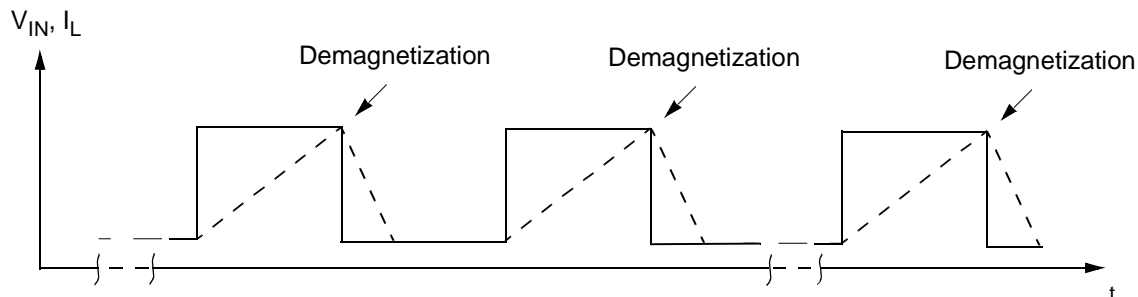

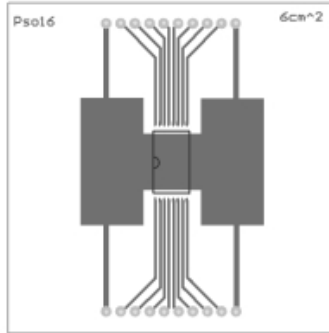
**PowerSO-16™ THERMAL DATA****PowerSO-16™ PC Board**

Layout condition of  $R_{th}$  and  $Z_{th}$  measurements (PCB FR4 area= 60mm x 60mm, PCB thickness=2mm, Cu thickness=35 $\mu$ m, Copper areas: 6cm<sup>2</sup>).

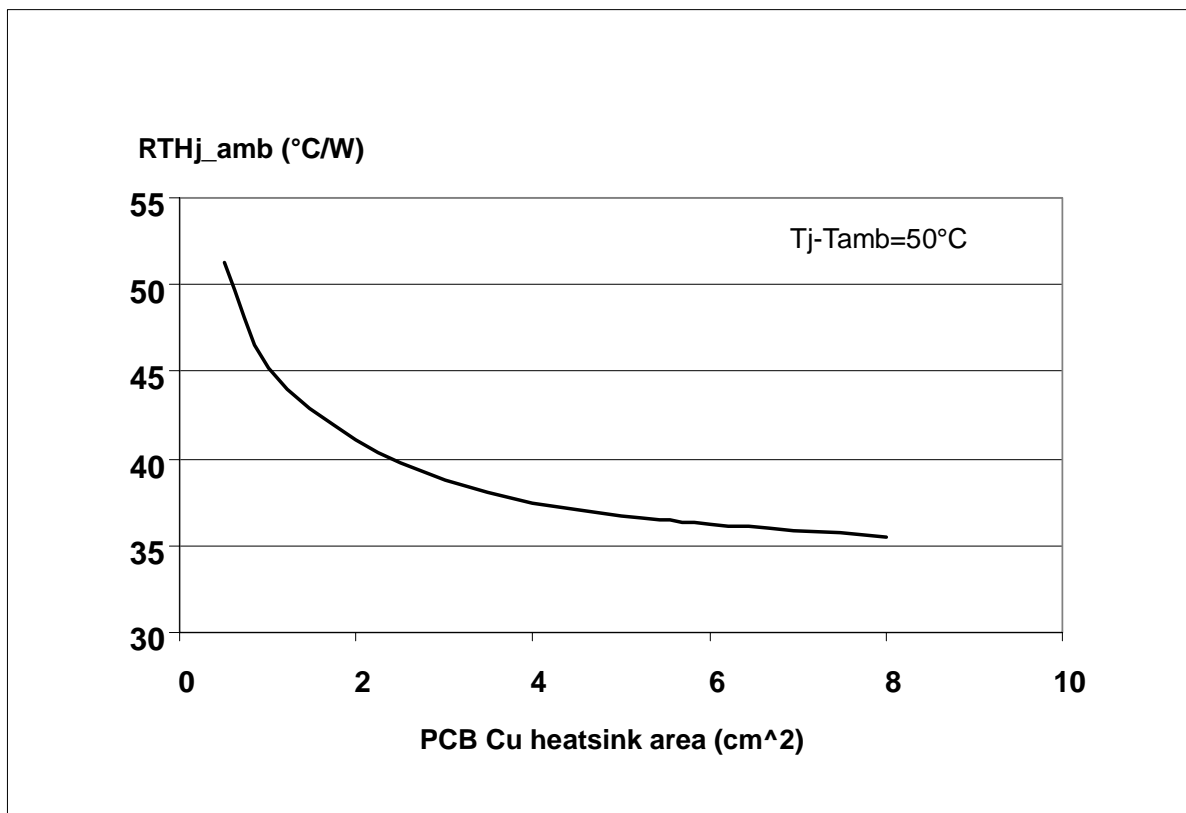
 **$R_{thj-amb}$  Vs PCB copper area in open box free air condition**

Thermal Impedance Junction Ambient Single Pulse

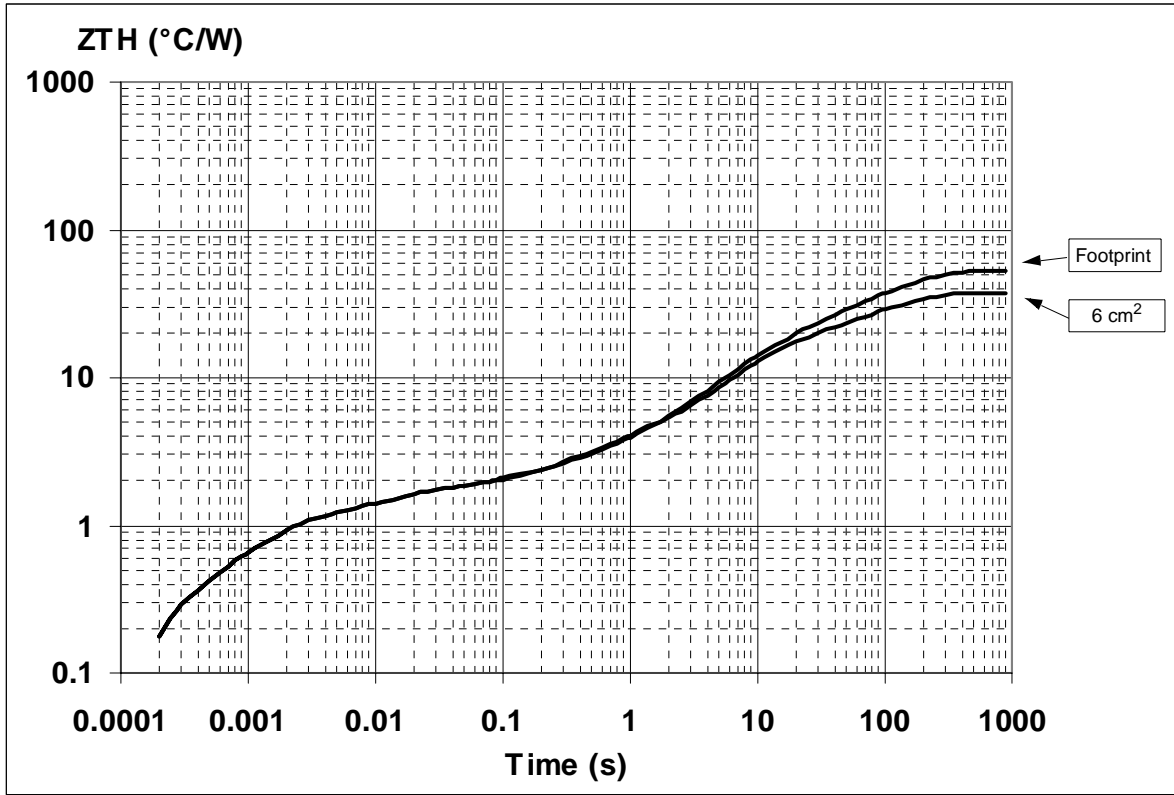

Thermal fitting model of a quad HSD in PowerSO-16

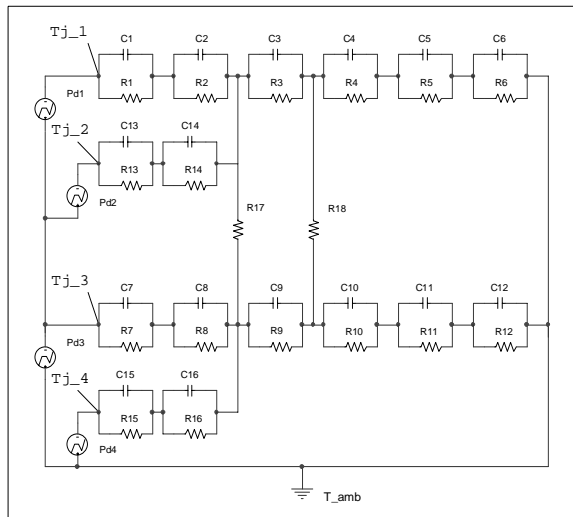

Pulse calculation formula

$$Z_{TH\delta} = R_{TH} \cdot \delta + Z_{THip}(1 - \delta)$$

where  $\delta = t_p / T$

Thermal Parameter

Area/island (cm <sup>2</sup> )	Footprint	6
R1 (°C/W)	0.18	
R2 (°C/W)	0.8	
R3 (°C/W)	0.7	
R4 (°C/W)	0.8	
R5 (°C/W)	13	
R6 (°C/W)	37	22
C1 (W.s/°C)	0.0006	
C2 (W.s/°C)	1.50E-03	
C3 (W.s/°C)	1.75E-02	
C4 (W.s/°C)	0.4	
C5 (W.s/°C)	0.75	
C6 (W.s/°C)	3	5

## POWERSO-16™ MECHANICAL DATA

DIM.	mm.		
	MIN.	TYP	MAX.
A1	0	0.05	1
A2	3.4	3.5	3.6
A3	1.2	1.3	1.4
A4	0.15	0.2	0.25
a		0.2	
b	0.27	0.35	0.43
c	0.23	0.27	0.32
D	9.4	9.5	9.6
D1	7.4	7.5	7.6
d	0	0.05	0.1
E (1)	13.85	14.1	14.35
E1	9.3	9.4	9.5
E2	7.3	7.4	7.5
E3	5.9	6.1	6.3
e		0.8	
e1		5.6	
F		0.5	
G		1.2	
L	0.8	1	1.1
R1			0.25
R2		0.8	
T	2°	5°	8°
T1		6° (typ.)	
T2		10° (typ.)	
Package Weight		(typ.)	

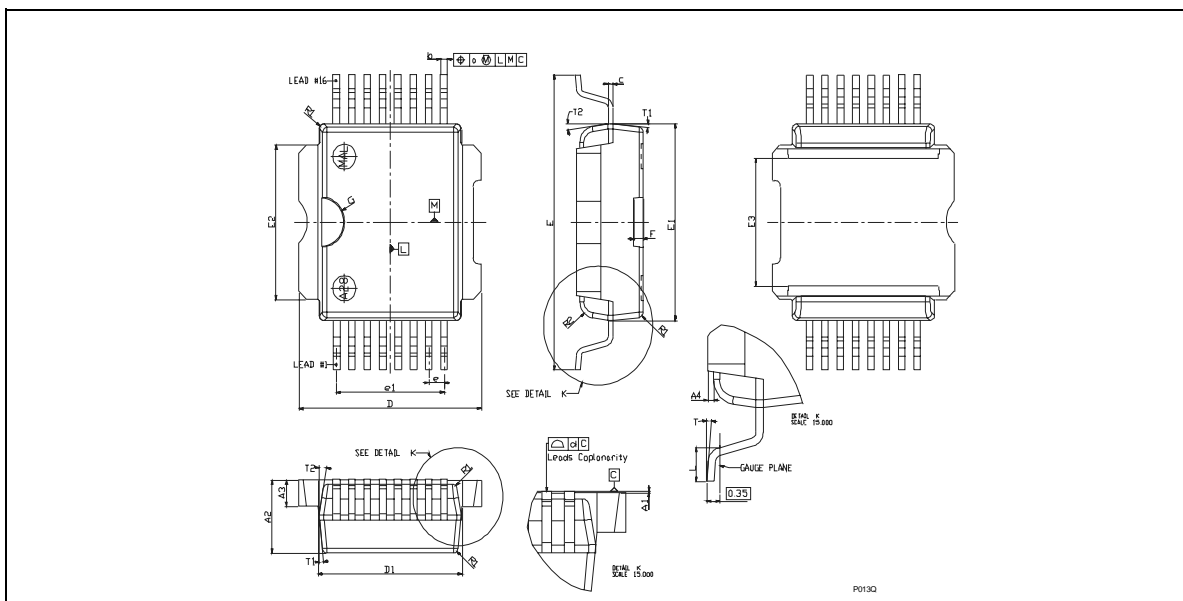

**PowerSO-16™ SUGGESTED PAD LAYOUT**

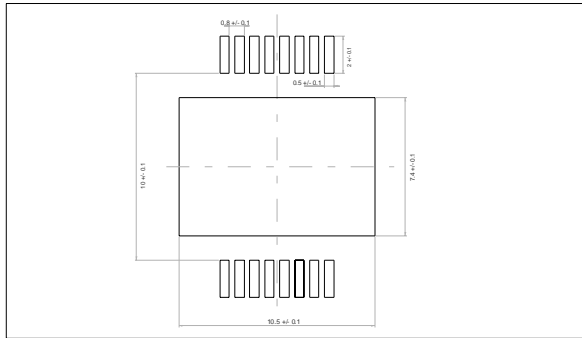

**TUBE SHIPMENT (no suffix)**

All dimensions are in mm.

Base Q.ty	Bulk Q.ty	Tube length (± 0.5)	A	B	C (± 0.1)
50	1000	532	4.9	17.2	0.8

**TAPE AND REEL SHIPMENT (suffix "13TR")**

**REEL DIMENSIONS**

Base Q.ty	600
Bulk Q.ty	600
A (max)	330
B (min)	1.5
C (± 0.2)	13
F	20.2
G (+ 2 / -0)	24.4
N (min)	60
T (max)	30.4

All dimensions are in mm.

**TAPE DIMENSIONS**  
According to Electronic Industries Association (EIA) Standard 481 rev. A, Feb. 1986

Tape width	W	24
Tape Hole Spacing	P0 (± 0.1)	4
Component Spacing	P	24
Hole Diameter	D (± 0.1/-0)	1.5
Hole Diameter	D1 (min)	1.5
Hole Position	F (± 0.05)	11.5
Compartment Depth	K (max)	6.5
Hole Spacing	P1 (± 0.1)	2

User Direction of Feed →

User direction of feed →

Information furnished is believed to be accurate and reliable. However, STMicroelectronics assumes no responsibility for the consequences of use of such information nor for any infringement of patents or other rights of third parties which may result from its use. No license is granted by implication or otherwise under any patent or patent rights of STMicroelectronics. Specifications mentioned in this publication are subject to change without notice. This publication supersedes and replaces all information previously supplied. STMicroelectronics products are not authorized for use as critical components in life support devices or systems without express written approval of STMicroelectronics. The ST logo is a trademark of STMicroelectronics

© 2002 STMicroelectronics - Printed in ITALY- All Rights Reserved.

STMicroelectronics GROUP OF COMPANIES

Australia - Brazil - Canada - China - Finland - France - Germany - Hong Kong - India - Israel - Italy - Japan - Malaysia -  
Malta - Morocco - Singapore - Spain - Sweden - Switzerland - United Kingdom - U.S.A.

<http://www.st.com>