

## Product Description

Stanford Microdevices' SGA-1163 is a Silicon Germanium HBT Heterostructure Bipolar Transistor (SiGe HBT) amplifier that offers excellent isolation and flat gain response for applications to 6 GHz.

This RFIC is a 2-stage design that provides high isolation of up to 40dB at 2 GHz and is fabricated using the latest SiGe HBT 50 GHz  $F_T$  process, featuring 1 micron emitters with  $V_{ce0} > 7V$ .

These unconditionally stable amplifiers have less than 1dB gain drift over 125°C operating range (-40C to +85C) and are ideal for use as buffer amplifiers in oscillator applications covering cellular, ISM and narrowband PCS bands.

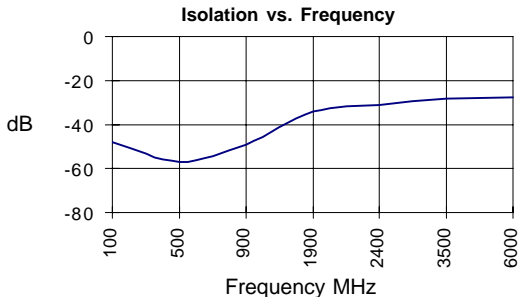

## SGA-1163

### DC-6000 MHz Silicon Germanium HBT Cascadeable Gain Block



### Product Features

- DC-6000 MHz Operation
- Excellent Isolation, >50 dB at 900 MHz
- Single Supply Voltage
- Unconditionally Stable
- 50 Ohms In/Out, Broadband Match for Operation from DC - 6 GHz

### Applications

- Buffer Amplifier for Oscillator Applications
- Broadband, High Isolation

Symbol	Parameters: Test Conditions: $Z_0 = 50 \text{ Ohms}$ , $I_d = 12 \text{ mA}$ , $T = 25^\circ\text{C}$		Units	Min.	Typ.	Max.
$P_{1dB}$	Output Power at 1dB Compression	$f = 850 \text{ MHz}$ $f = 1950 \text{ MHz}$	dBm dBm		-3.3 -4.6	
$S_{21}$	Small Signal Gain	$f = \text{DC} - 1000 \text{ MHz}$ $f = 1000 - 2000 \text{ MHz}$ $f = 2000 - 6000 \text{ MHz}$	dB dB dB	10.5	11.7 11.2 9.5	
$S_{12}$	Reverse Isolation	$f = \text{DC} - 1000 \text{ MHz}$ $f = 1000 - 2000 \text{ MHz}$ $f = 2000 - 6000 \text{ MHz}$	dB dB dB		53.3 38.3 28.5	
$S_{11}$	Input VSWR	$f = \text{DC} - 2400 \text{ MHz}$ $f = 2400 - 6000 \text{ MHz}$	-		1.3:1 1.8:1	
$S_{22}$	Output VSWR	$f = \text{DC} - 2400 \text{ MHz}$ $f = 2400 - 6000 \text{ MHz}$	-		2.1:1 2.2:1	
$IP_3$	Third Order Intercept Point Power out per Tone = -20 dBm	$f = 850 \text{ MHz}$ $f = 1950 \text{ MHz}$	dBm dBm		7.9 6.3	
NF	Noise Figure	$f = \text{DC} - 1000 \text{ MHz}$ $f = 1000 - 2400 \text{ MHz}$	dB dB		3.1 3.4	
$T_D$	Group Delay	$f = 1000 \text{ MHz}$	pS		118	
$V_D$	Device Voltage		V	4.2	4.6	5.0

The information provided herein is believed to be reliable at press time. Stanford Microdevices assumes no responsibility for inaccuracies or omissions. Stanford Microdevices assumes no responsibility for the use of this information, and all such information shall be entirely at the user's own risk. Prices and specifications are subject to change without notice. No patent rights or licenses to any of the circuits described herein are implied or granted to any third party. Stanford Microdevices does not authorize or warrant any Stanford Microdevices product for use in life-support devices and/or systems.  
Copyright 1999 Stanford Microdevices, Inc. All worldwide rights reserved.

Parameter	Specification			Unit	Test Condition
	Min	Typ.	Max.		
<b>Bandwidth</b> Frequency Range	DC		6000	MHz	T= 25C
<b>Device Bias</b> Operating Voltage Operating Current		4.6 12		V mA	T= 25C
<b>500 MHz</b> Gain Noise Figure Output IP3 Output P1dB Input Return Loss Isolation		11.8 3.1 8.7 -3.8 31.9 62.3		dB dB dBm dBm dB dB	T= 25C
<b>850 MHz</b> Gain Noise Figure Output IP3 Output P1dB Input Return Loss Isolation		11.5 3.1 7.9 -3.3 33.1 47.6		dB dB dBm dBm dB dB	T= 25C
<b>1950 MHz</b> Gain Noise Figure Output IP3 Output P1dB Input Return Loss Isolation		11.2 3.4 6.3 -4.6 15.7 34.3		dB dB dBm dBm dB dB	T= 25C
<b>2400 MHz</b> Gain Noise Figure Output IP3 Output P1dB Input Return Loss Isolation		11.4 3.4 5.7 -4.4 17.8 30.2		dB dB dBm dBm dB dB	T= 25C

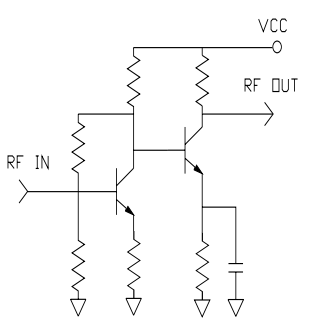
Pin #	Function	Description	Device Schematic
1	GND	Connection to ground. Use via holes for best performance to reduce lead inductance as close to ground leads as possible.	
2	GND	Sames as Pin 1	
3	RF IN	RF input pin. This pin requires the use of an external DC blocking capacitor chosen for the frequency of operation.	
4	Vcc	Supply connection. This pin should be bypassed with a suitable capacitor(s).	
5	GND	Sames as Pin 1	
6	RF OUT	RF output and bias pin. DC voltage is present on this pin, therefore a DC blocking capacitor is necessary for proper operation.	

**Application Schematic for +5V Operation at 900 MHz**

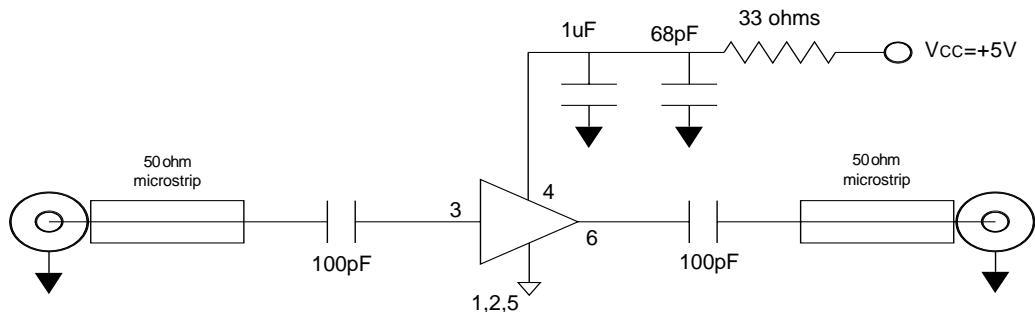

**Application Schematic for +5V Operation at 1900 MHz**

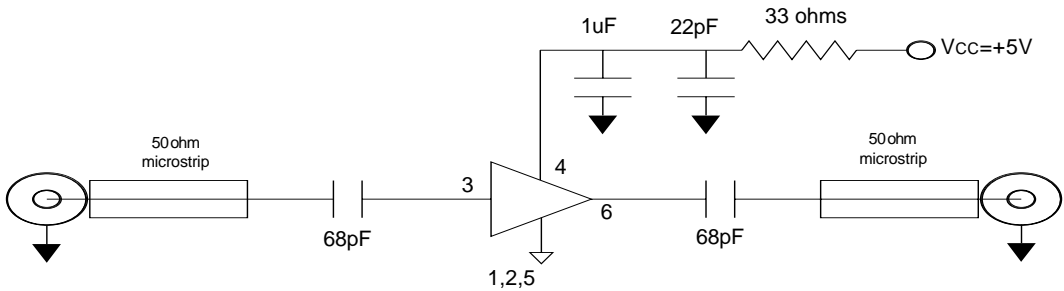

The information provided herein is believed to be reliable at press time. Stanford Microdevices assumes no responsibility for inaccuracies or omissions. Stanford Microdevices assumes no responsibility for the use of this information, and all such information shall be entirely at the user's own risk. Prices and specifications are subject to change without notice. No patent rights or licenses to any of the circuits described herein are implied or granted to any third party. Stanford Microdevices does not authorize or warrant any Stanford Microdevices product for use in life-support devices and/or systems. Copyright 1999 Stanford Microdevices, Inc. All worldwide rights reserved.

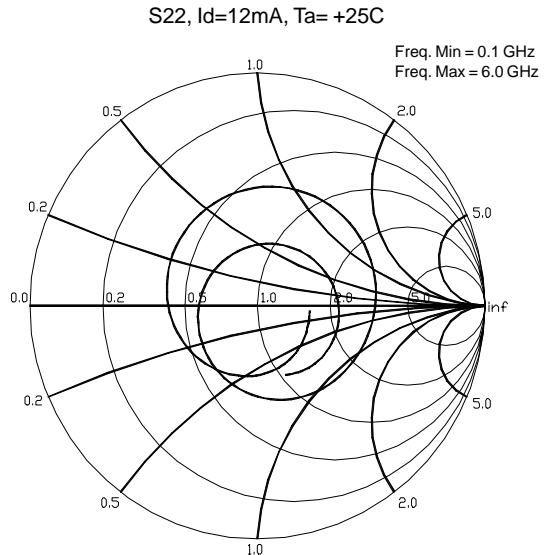
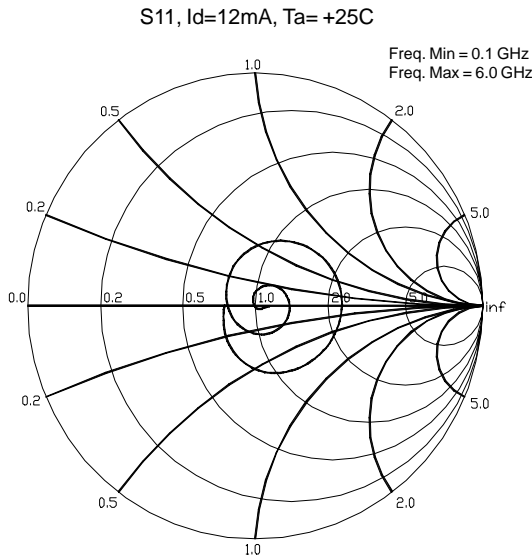
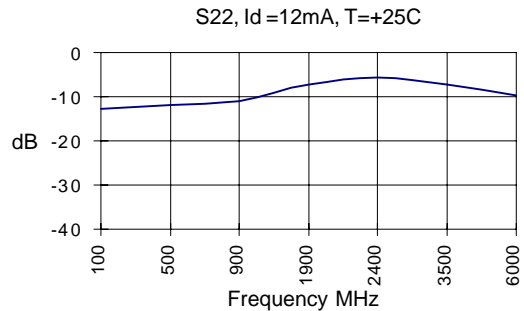
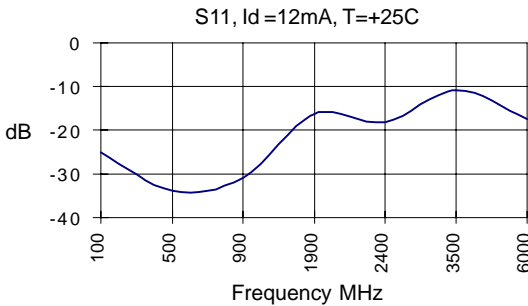
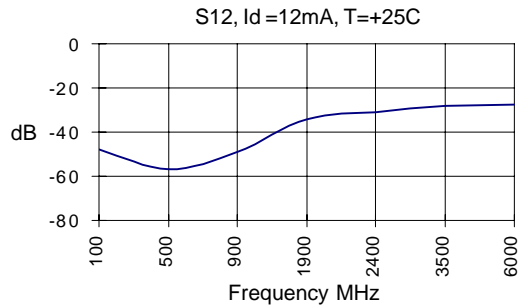
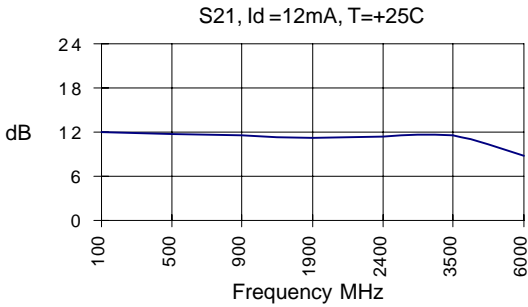

The information provided herein is believed to be reliable at press time. Stanford Microdevices assumes no responsibility for inaccuracies or omissions. Stanford Microdevices assumes no responsibility for the use of this information, and all such information shall be entirely at the user's own risk. Prices and specifications are subject to change without notice. No patent rights or licenses to any of the circuits described herein are implied or granted to any third party. Stanford Microdevices does not authorize or warrant any Stanford Microdevices product for use in life-support devices and/or systems. Copyright 1999 Stanford Microdevices, Inc. All worldwide rights reserved.

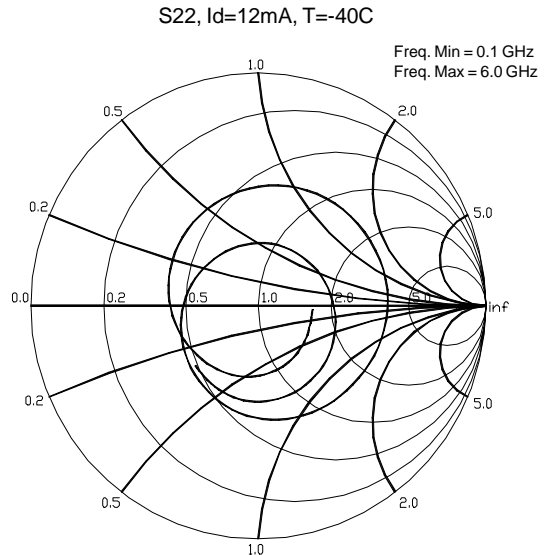
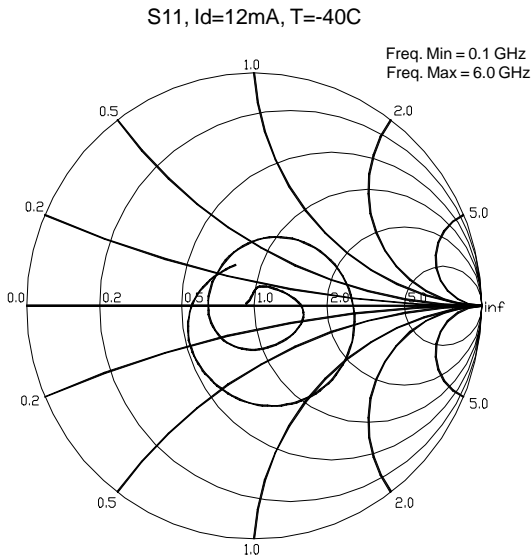
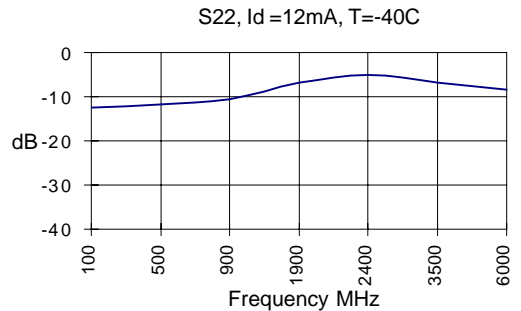
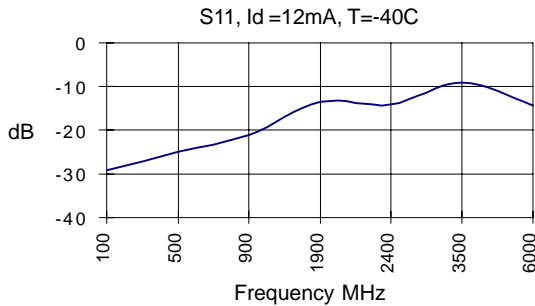
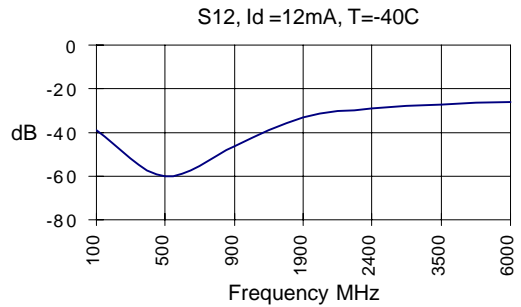
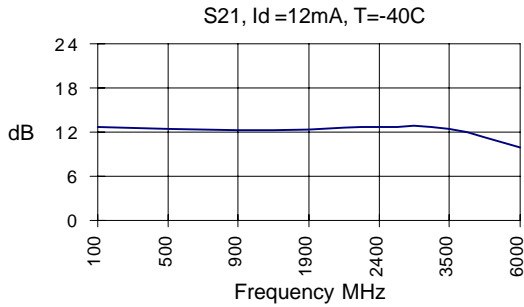

The information provided herein is believed to be reliable at press time. Stanford Microdevices assumes no responsibility for inaccuracies or omissions. Stanford Microdevices assumes no responsibility for the use of this information, and all such information shall be entirely at the user's own risk. Prices and specifications are subject to change without notice. No patent rights or licenses to any of the circuits described herein are implied or granted to any third party. Stanford Microdevices does not authorize or warrant any Stanford Microdevices product for use in life-support devices and/or systems. Copyright 1999 Stanford Microdevices, Inc. All worldwide rights reserved.

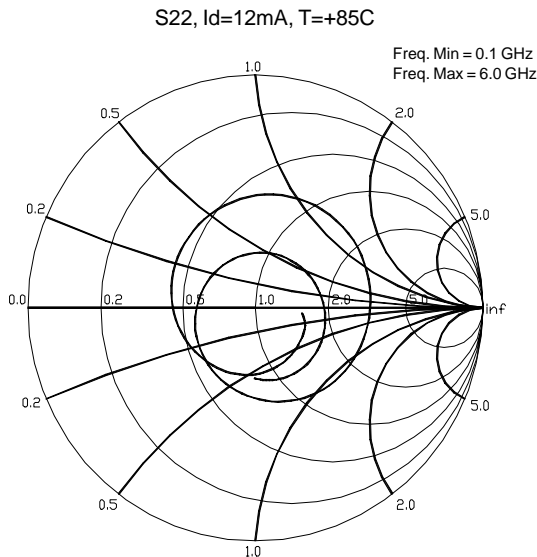
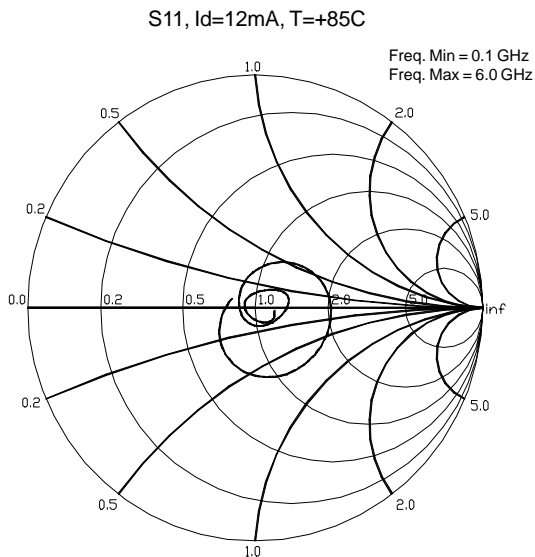
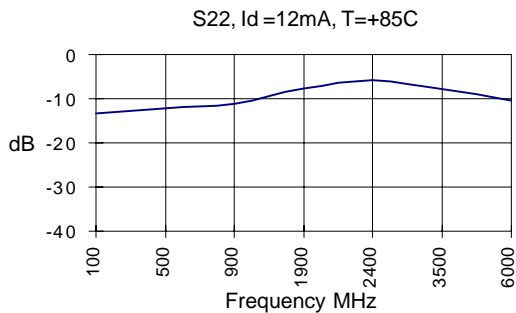
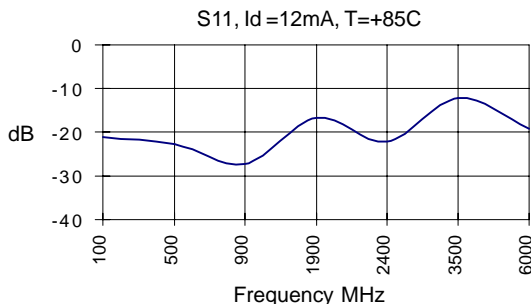
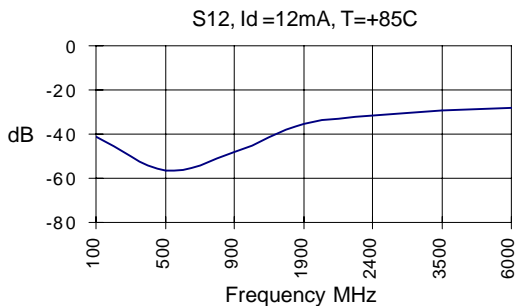
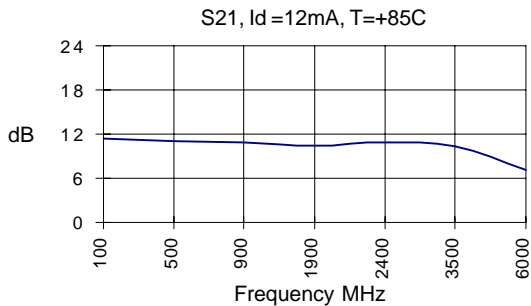

The information provided herein is believed to be reliable at press time. Stanford Microdevices assumes no responsibility for inaccuracies or omissions. Stanford Microdevices assumes no responsibility for the use of this information, and all such information shall be entirely at the user's own risk. Prices and specifications are subject to change without notice. No patent rights or licenses to any of the circuits described herein are implied or granted to any third party. Stanford Microdevices does not authorize or warrant any Stanford Microdevices product for use in life-support devices and/or systems. Copyright 1999 Stanford Microdevices, Inc. All worldwide rights reserved.

### Absolute Maximum Ratings

Parameter	Value	Unit
Supply Current	24	mA
Operating Temperature	-40 to +85	C
Maximum Input Power	-9	dBm
Storage Temperature Range	-40 to +85	C
Operating Junction Temperature	+125	C

#### Caution:



Operation of this device above any one of these parameters may cause permanent damage. Appropriate precautions in handling, packaging and testing devices must be observed.

Thermal Resistance (Lead-Junction):  
255° C/W

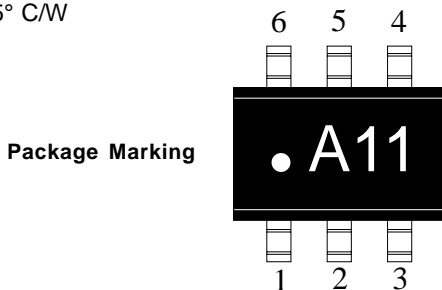

### Part Number Ordering Information

Part Number	Reel Size	Devices/Reel
SGA-1163-TR1	7"	3000

#### Recommended Bias Resistor Values

Supply Voltage(Vs)	5V	6V	7.5V	9V	12V
Rbias (Ohms)	33	117	242	367	617

Pin Designation	
1	GND
2	GND
3	RF in
4	Vcc
5	GND
6	RF out

Note: Pin 1 is on lower left when you can read package marking

### Package Dimensions

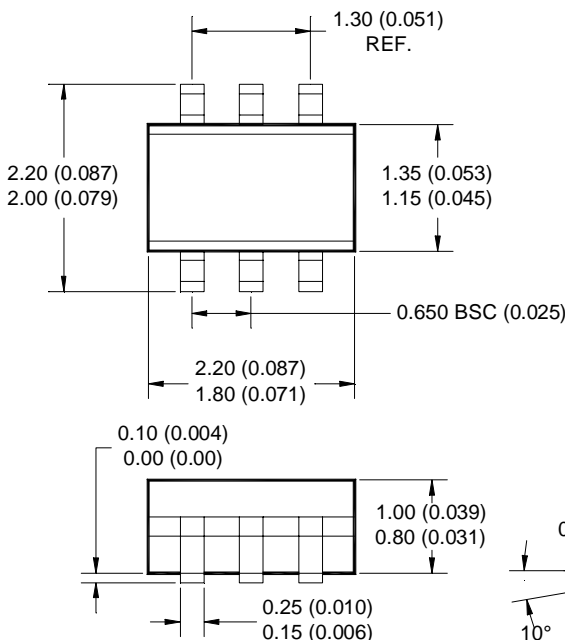

### Pad Layout

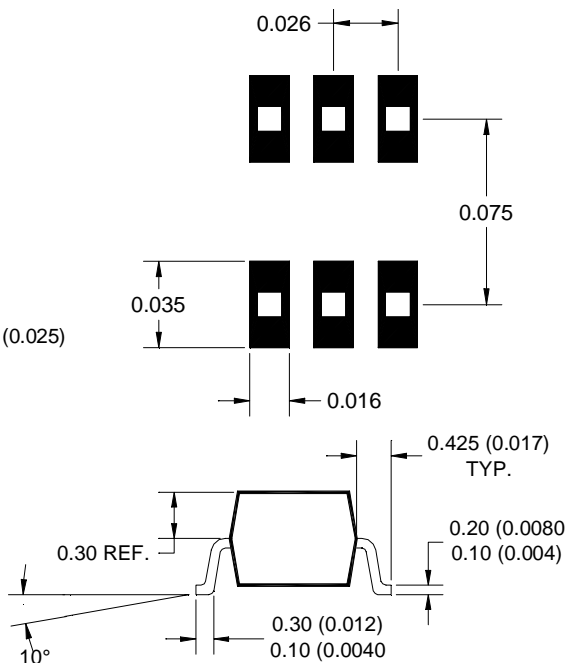

The information provided herein is believed to be reliable at press time. Stanford Microdevices assumes no responsibility for inaccuracies or omissions. Stanford Microdevices assumes no responsibility for the use of this information, and all such information shall be entirely at the user's own risk. Prices and specifications are subject to change without notice. No patent rights or licenses to any of the circuits described herein are implied or granted to any third party. Stanford Microdevices does not authorize or warrant any Stanford Microdevices product for use in life-support devices and/or systems. Copyright 1999 Stanford Microdevices, Inc. All worldwide rights reserved.