

Abstract

Stanford Microdevices' SGA-9289 is a high performance SiGe amplifier designed for operation from DC to 3500 MHz. The amplifier is manufactured using the latest Silicon Germanium Heterostructure Bipolar Transistor (SiGe HBT) process. The process has a $V_{BCEO}=8V$ and an $f_T=25$ GHz. The SiGe HBT process makes the SGA-9289 a very cost-effective solution for applications requiring high linearity at moderate biasing levels. This application note illustrates several application circuits for key frequency bands in the 800-2500 MHz spectrum.

Introduction

The application circuits were designed to achieve the optimum combination of P_{1dB} and OIP_3 while maintaining flat gain and reasonable return losses. Special consideration was given to insure amplifier stability at low frequencies where the device exhibits high gain. These designs were created to illustrate the general performance capabilities of the device under CW conditions. Users may wish to modify these designs to achieve optimum performance under specific input conditions and system requirements.

The circuits contain only surface mountable devices and were designed with automated manufacturing requirements in mind. All recommended components are standard values available from multiple manufacturers. The components specified in the bill of materials (BOM) have known parasitics, which in some cases are critical to the circuit's performance. Deviating from the recommended BOM may result in a performance shift due to varying parasitics – primarily in the inductors and capacitors.

Biasing Techniques

These SiGe HBT amplifiers exhibit a “soft” breakdown effect ($V_{BCEO}=7.5V$ minimum) which allows for large signal operation at $V_{CE}=5V$. The user should insure that under large signal conditions the source and load impedances presented to the device don't result in excessive collector currents near breakdown. Small signal operation with $V_{CE}<7V$ is acceptable.

SGA-9289
Silicon Germanium HBT Amplifier

Product Features

- DC-3500 MHz Operation
- High Output IP3, +41.5 dBm Typical at 1.96 GHz
- 11.0 dB Gain Typical at 1.96 GHz
- 28.6 dBm P1dB Typical at 1.96 GHz
- Cost Effective

Applications

- Wireless Infrastructure Driver Amplifiers
- CATV Amplifiers
- Wireless Data, WLL Amplifiers

Absolute Maximum Ratings

Parameter	Symbol	Value	Unit
Base Current	I_B	20	mA
Collector Current	I_C	400	mA
Collector - Emitter Voltage	V_{CEO}	7.0	V
Collector - Base Voltage	V_{CBO}	18	V
Emitter - Base Voltage	V_{EBO}	4.8	V
Operating Temperature	T_{OP}	-40 to +85	C
Storage Temperature Range	T_{stor}	-40 to +150	C
Operating Junction Temperature	T_J	+150	C

All HBT amplifiers are subject to device current variation due to the decreasing nature of the internal V_{BE} with increasing temperature. In the absence of an active bias circuit or resistive feedback, the decreasing V_{BE} will result in increased base and collector currents. As the collector current continues to increase under constant V_{CE} conditions the device may eventually exceed its maximum dissipated power limit resulting in permanent device damage. The designs included in this application note contain passive bias circuits that stabilize the device current over temperature and desensitize the circuit to device process variation.

The passive bias circuits used in these designs include a dropping resistor in the collector bias line and a voltage divider from collector-to-base. Using this scheme the amplifier can be biased from a single supply voltage. The collector-dropping resistor is sized to drop 2-3V depending on the desired V_{CE} . The voltage divider from collector-to-base, in conjunction with the dropping resistor, will stabilize the device current over temperature. Configuring the voltage divider such that the shunt current is 5-10 times larger than the desired base current desensitizes the circuit to device process variation. These two feedback mechanisms are sufficient to insure consistent performance over temperature and device process variations. Note that the voltage drop is clearly dependent on the nominal collector current and can be adjusted to generate the desired V_{CE} from a fixed supply rail. The user should test the circuit over the operational extremes to guarantee adequate performance if the feedback mechanisms are reduced.

An active bias circuit can be implemented if the user does not wish to sacrifice the voltage required by the aforementioned passive circuit. There are various active bias schemes suitable for HBTs. The user should choose an active bias circuit that best meets his cost, complexity and performance requirements.

Circuit Details

SMDI will provide the detailed layout (AutoCad format) to users wishing to use the exact same layout and PCB material shown in the following circuits. The circuits recommended within this application note were designed using the following PCB stack up:

- Material: GETEK™ ML200C
- Core thickness: 0.031"
- Copper cladding: 1oz both sides
- Dielectric constant: 4.1
- Dielectric loss tangent: 0.0089 (@ 1 GHz)

Customers not wishing to use the exact material and layouts shown in this application note can design their own PCB using the critical transmission line impedances and phase lengths shown in the BOMs and layouts.

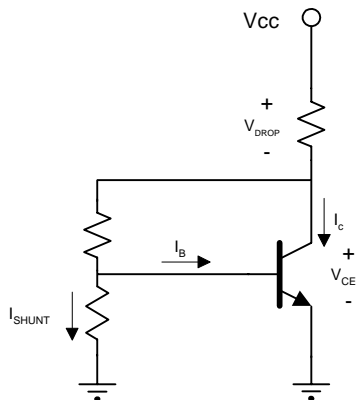

Passive Bias Circuit Topology

870-960 MHz Application Circuit ($V_{CE}=3V, I_{CQ}=315mA, 25^{\circ}C$)

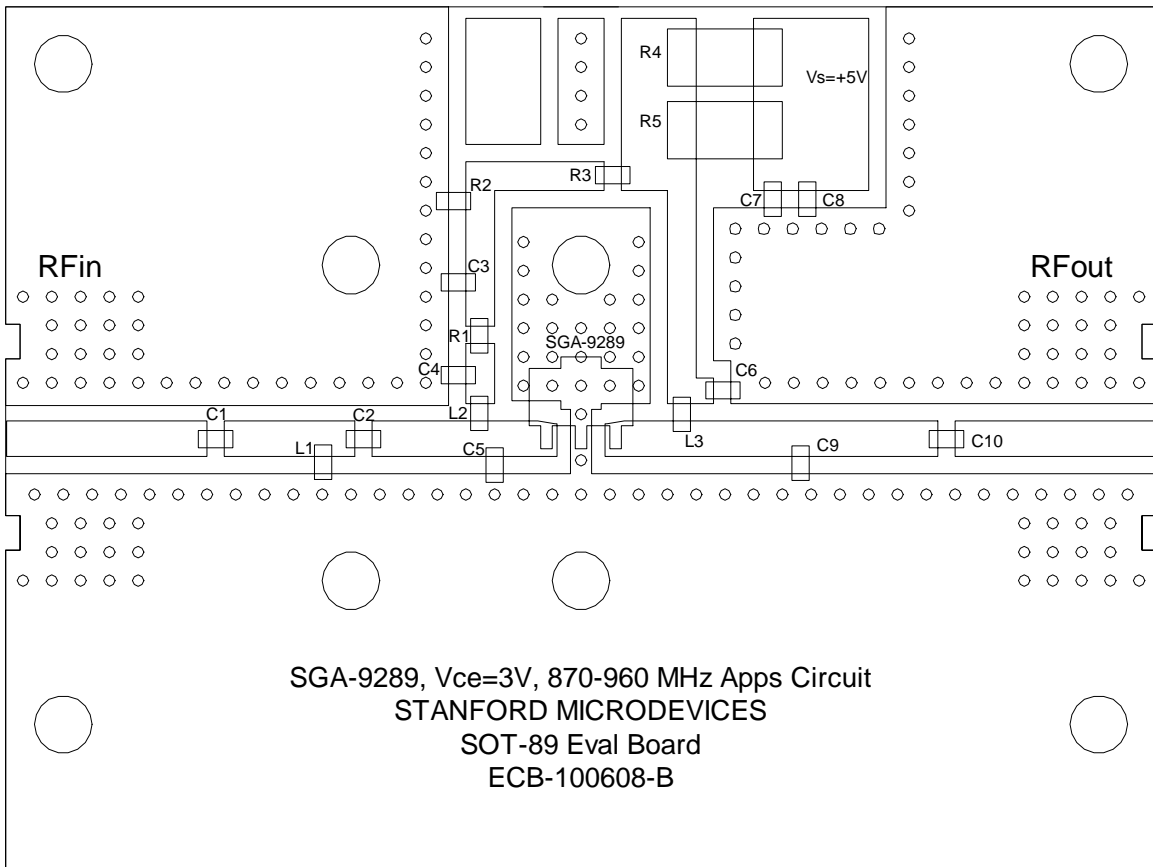

Ref Des.	Value	Part Number
C 1,10	68 pF	Rohm MCH18 series
C 2	3.9 pF	Rohm MCH18 series
C 3,7	.1 uF	Rohm MCH18 series
C 4,6	39 pF	Rohm MCH18 series
C 5	10 pF	Rohm MCH18 series
C 8	1000 pF	Rohm MCH18 series
C 9	6.8 pF	Rohm MCH18 series
L 1	6.8 nH	TOKO LL1608-series
L 2,3	82 nH	TOKO LL1608-series
R 1	10 ohms	Rohm MCH18 series
R 2	56 ohms	Rohm MCH18 series
R 3	150 ohms	Rohm MCH18 series
R 4,5	12 ohms	2512 pkg 1 WATT

Ref. Des.	Value
Z1	50 Ohms, 19 deg. @ 915 MHz
Z2	50 Ohms, 6 deg. @ 915 MHz
Z3	50 Ohms, 9.3 deg. @ 915 MHz
Z4	50 Ohms, 1.4 deg. @ 915 MHz
Z5	50 Ohms, 5.3 deg. @ 915 MHz
Z6	50 Ohms, 14.1 deg. @ 915 MHz
Z7	50 Ohms, 21.7 deg. @ 915 MHz
Z8	50 Ohms, 22.1 deg. @ 915 MHz

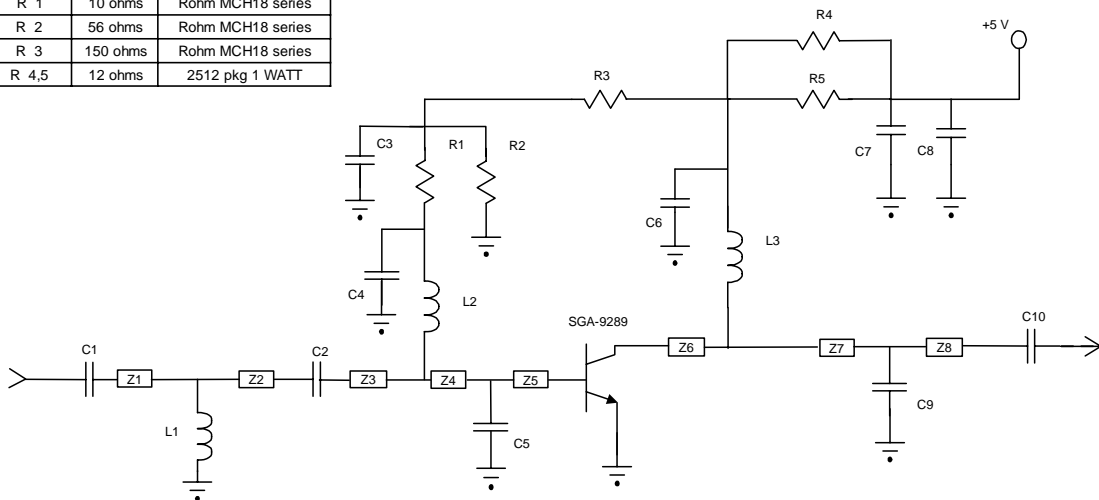

Typical Performance - 870-960 MHz Application Circuit ($V_{CE}=3V, I_{CQ}=315mA, 25^{\circ}C$)

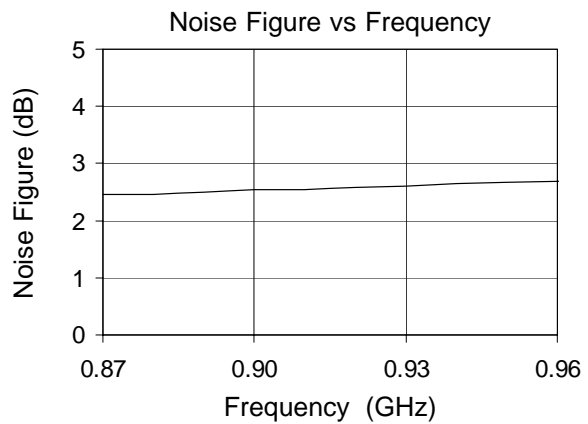
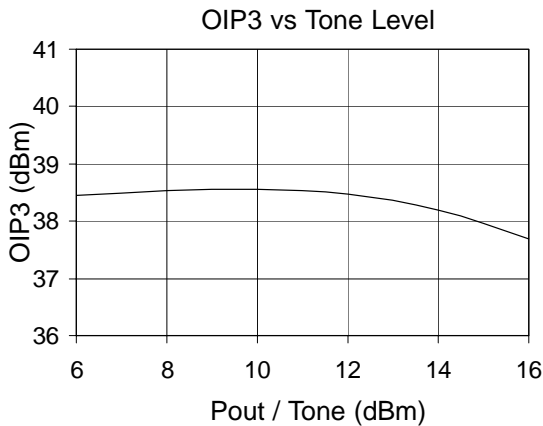
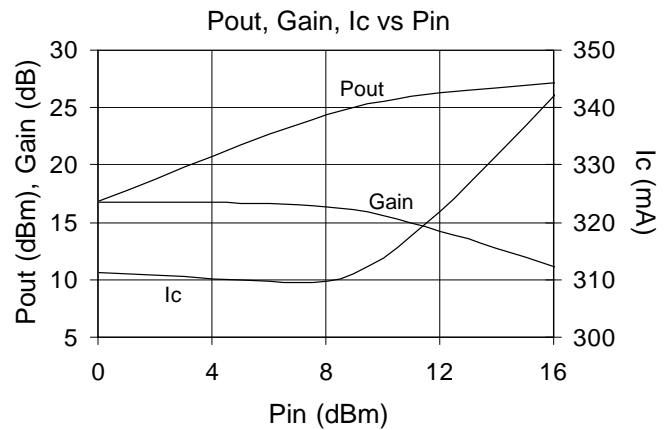
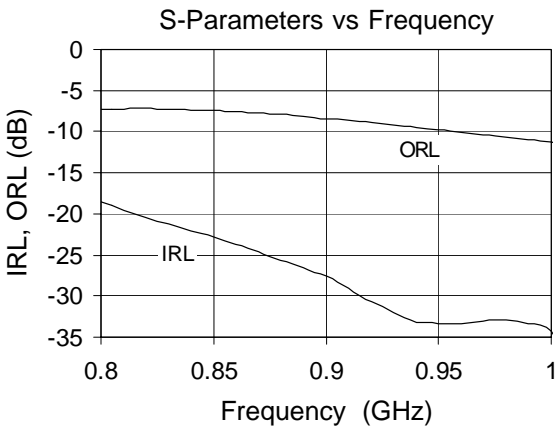
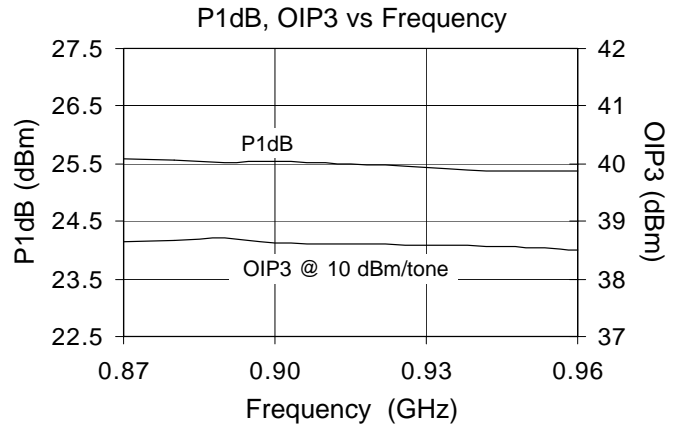
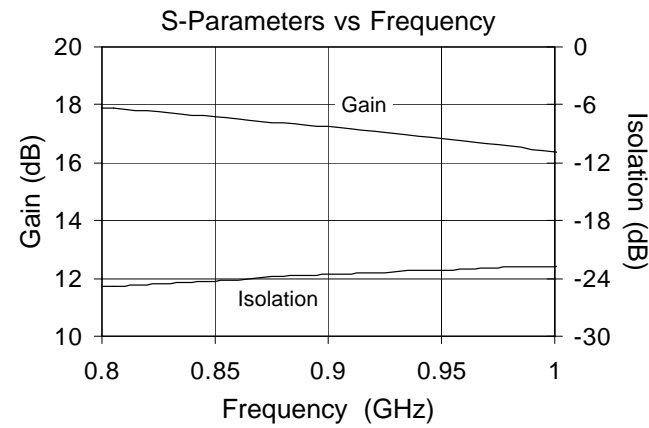

Freq (GHz)	P1dB (dBm)	OIP3 (dBm)	Gain (dB)	S11 (dB)	S22 (dB)	NF (dB)
0.880	25.6	38.7	17.3	-25.7	-7.9	2.5
0.915	25.5	38.6	17.0	-29.7	-8.7	2.5
0.945	25.4	38.6	16.8	-33.0	-9.6	2.6

870-960 MHz Application Circuit ($V_{CE}=5V, I_{CQ}=340mA, 25^{\circ}C$)

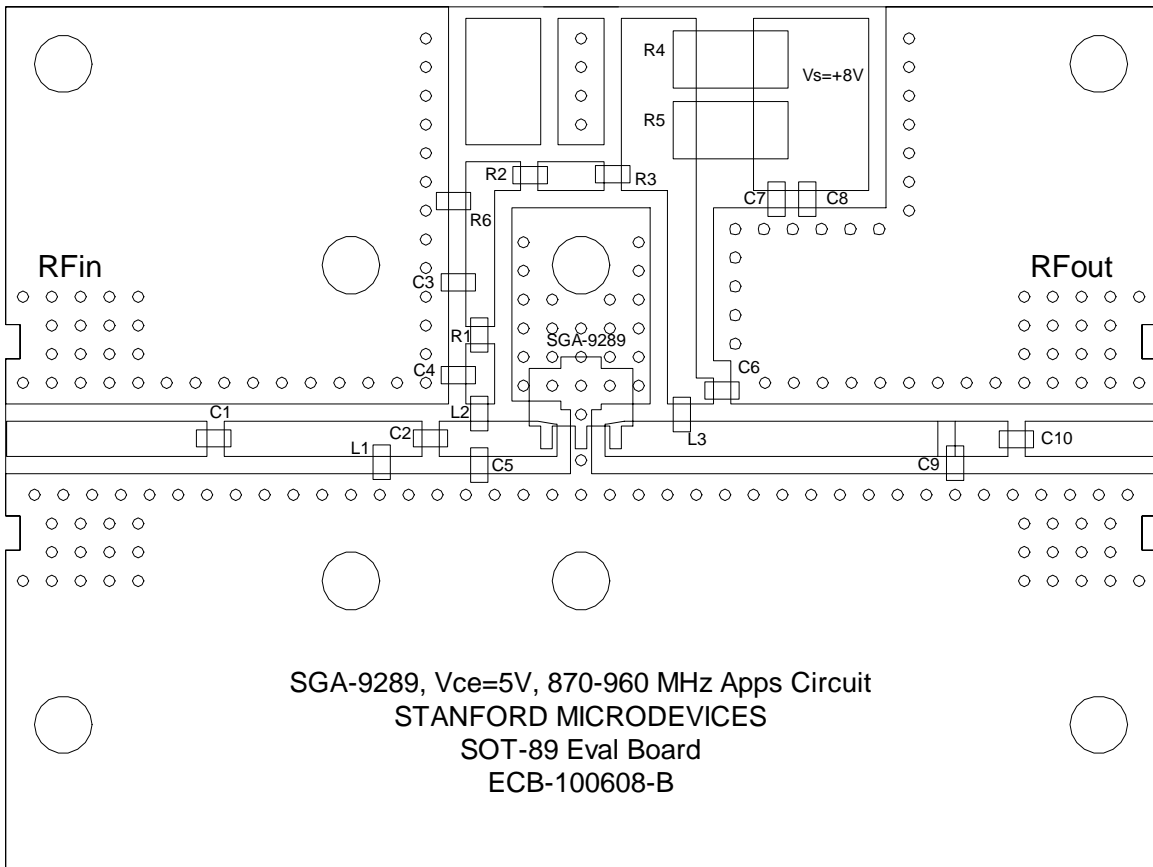

Ref Des.	Value	Part Number
C 1,10	68 pF	Rohm MCH18 series
C 2,9	3.9 pF	Rohm MCH18 series
C 3,7	.1 uF	Rohm MCH18 series
C 4,6	39 pF	Rohm MCH18 series
C 5	10 pF	Rohm MCH18 series
C 8	1000 pF	Rohm MCH18 series
L 1	10 nH	TOKO LL1608-FH82NT
L 2,3	82 nH	TOKO LL1608-FH82NT
R 1	10 ohms	size 0603
R 2	36 ohms	size 0603
R 3	220 ohms	size 0603
R 4	16 ohms	2512 pkg 1 WATT
R 5	18 ohms	2512 pkg 1 WATT

Ref. Des.	Value
Z1	50 Ohms, 13.6 deg. @ 915 MHz
Z2	50 Ohms, 3.5 deg. @ 915 MHz
Z3	50 Ohms, 3.4 deg. @ 915 MHz
Z4	50 Ohms, 6.7 deg. @ 915 MHz
Z5	50 Ohms, 6.6 deg. @ 915 MHz
Z6	50 Ohms, 23.5 deg. @ 915 MHz
Z7	50 Ohms, 4.5 deg. @ 915 MHz

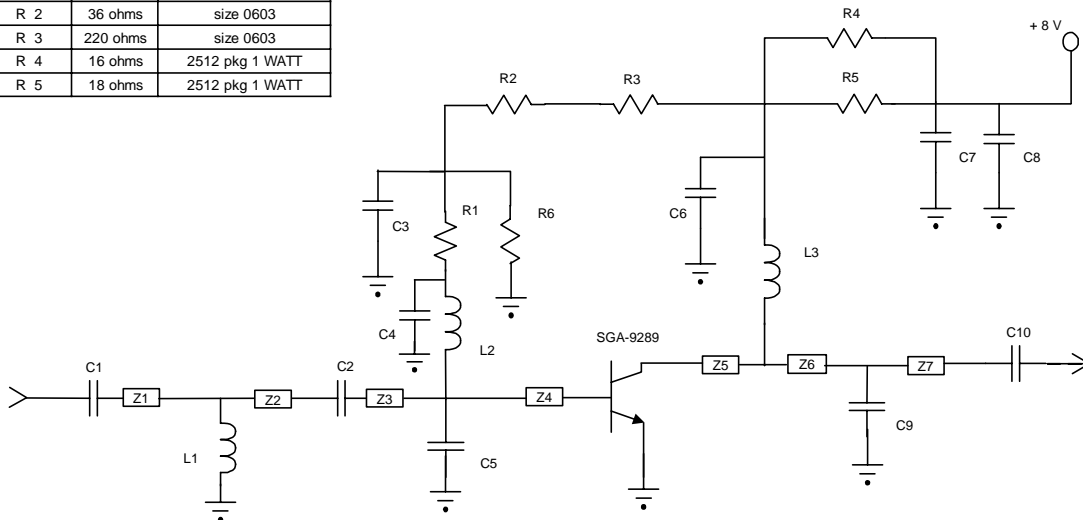

Typical Performance - 870-960 MHz Application Circuit ($V_{CE}=5V, I_{CQ}=340mA, 25^{\circ}C$)

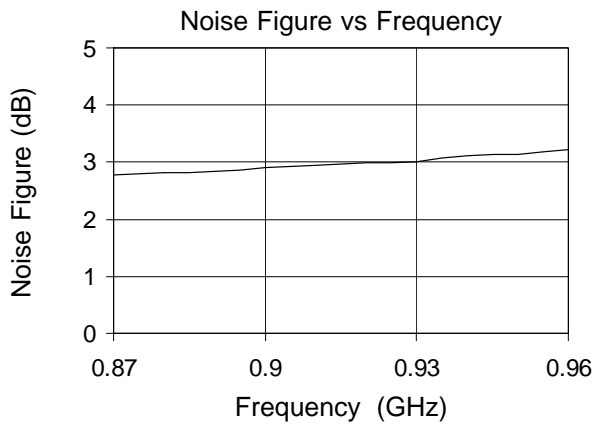
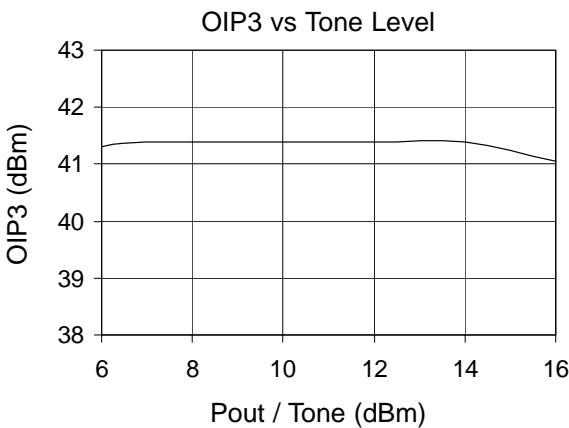
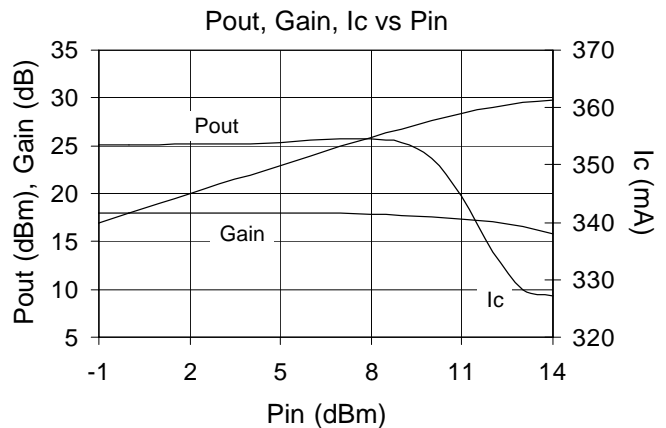
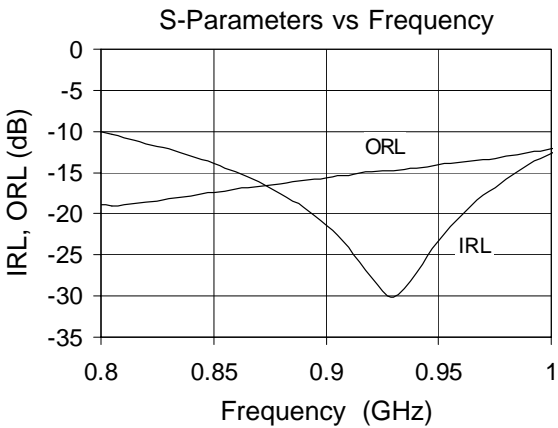
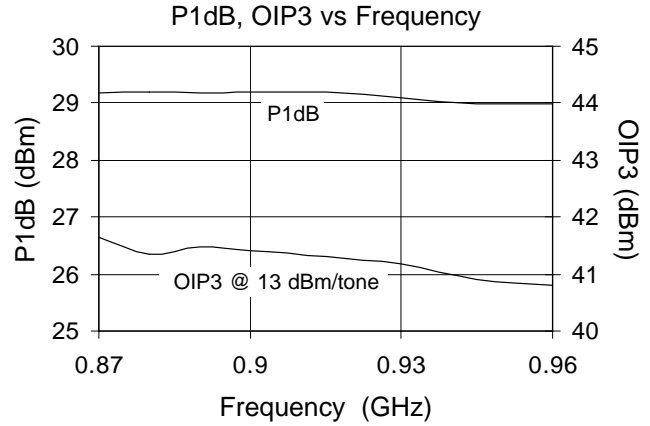
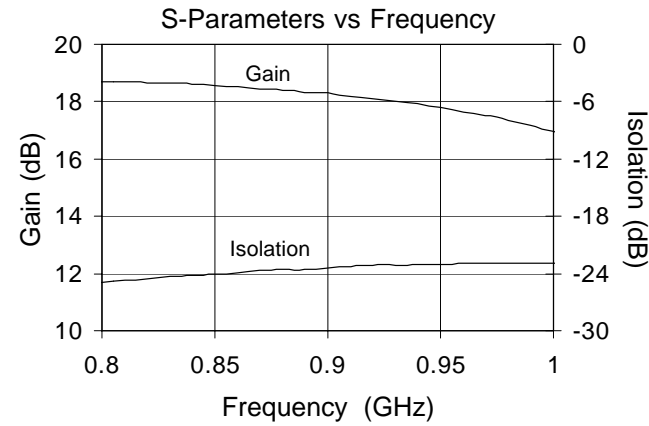

Freq (GHz)	P1dB (dBm)	OIP3 (dBm)	Gain (dB)	S11 (dB)	S22 (dB)	NF (dB)
0.880	29.2	41.4	18.2	-17.6	-16.4	2.8
0.915	29.2	41.3	17.9	-25.8	-15.1	2.9
0.945	29.0	40.9	17.7	-25.2	-14.3	2.9

1930-1990 MHz Application Circuit ($V_{CE}=3V, I_{CQ}=315mA, 25^{\circ}C$)

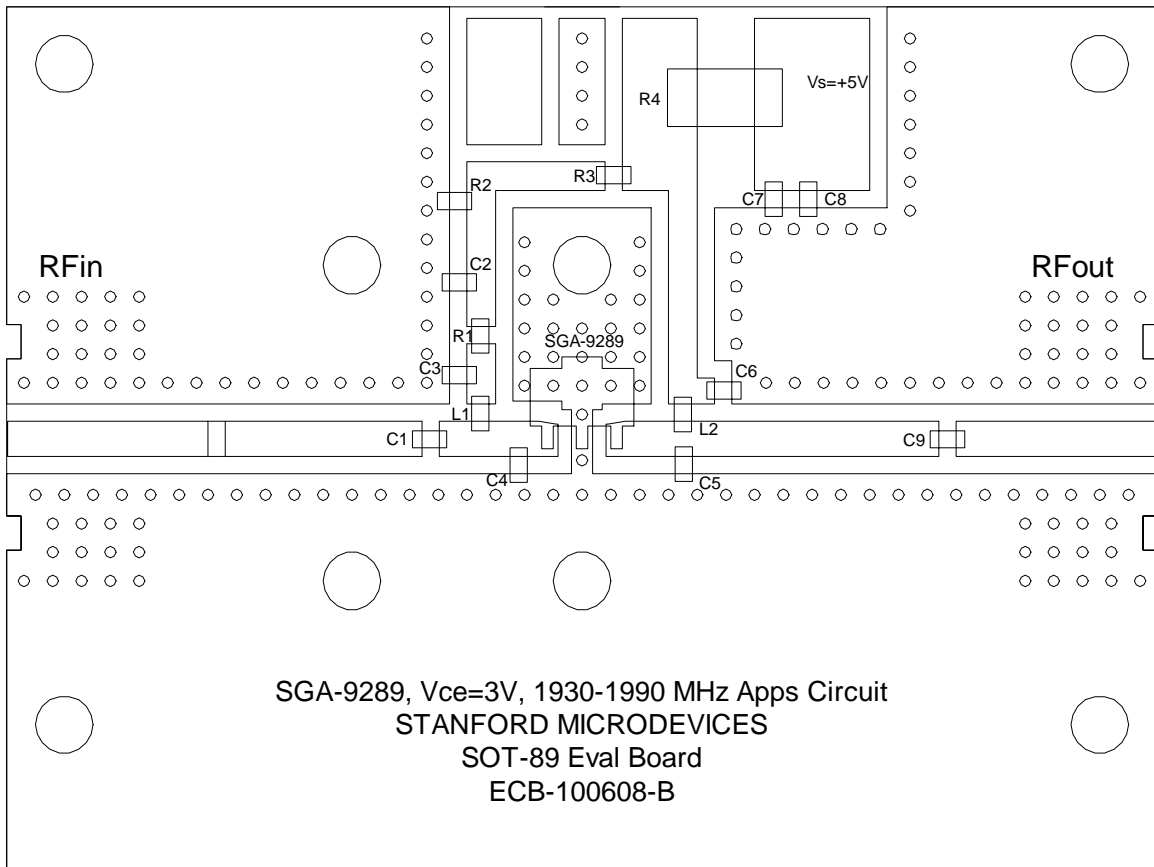

Ref Des.	Value	Part Number
C 1	1.5 pF	Rohm MCH18 series
C 2,7	0.1 uF	Rohm MCH18 series
C 3,6,9	12 pF	Rohm MCH18 series
C 4,5	2.2 pF	Rohm MCH18 series
C 8	1000 pF	Rohm MCH18 series
L 1,2	22 nH	TOKO LL1608-series
R 1	10 ohms	Rohm MCH18 series
R 2	56 ohms	Rohm MCH18 series
R 3	150 ohms	Rohm MCH18 series
R 4,5	12 ohms	2512 pkg 1 WATT

Ref. Des.	Value
Z1	50 Ohms, 7.7 deg. @ 1960 MHz
Z2	50 Ohms, 6.9 deg. @ 1960 MHz
Z3	50 Ohms, 7.2 deg. @ 1960 MHz
Z4	50 Ohms, 14.3 deg. @ 1960 MHz
Z5	50 Ohms, 43.8 deg. @ 1960 MHz

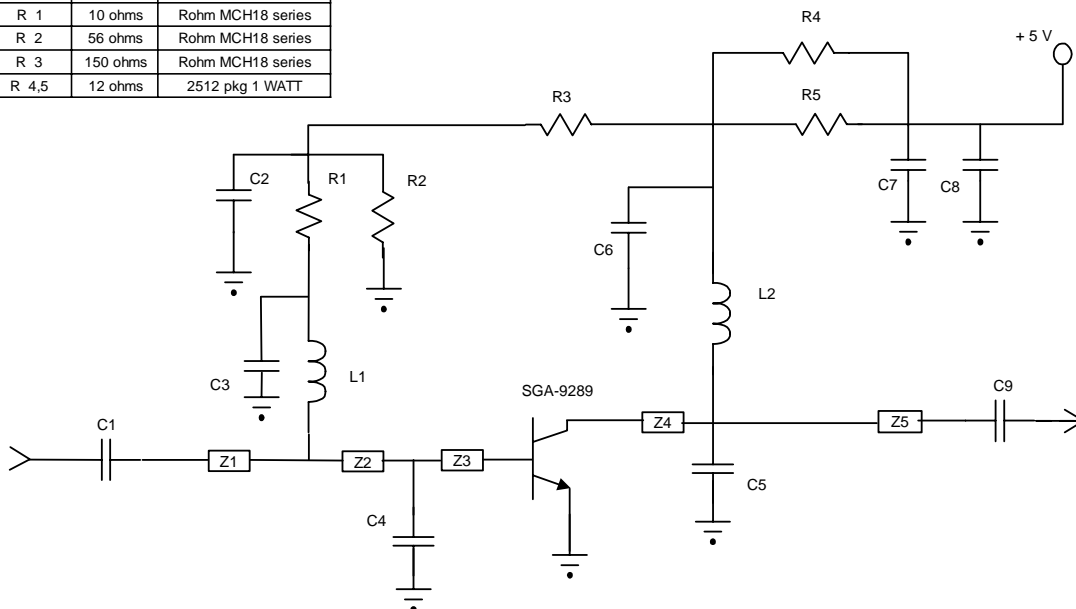

Typical Performance - 1930-1990 MHz Application Circuit ($V_{CE}=3V, I_{CQ}=315mA, 25^{\circ}C$)

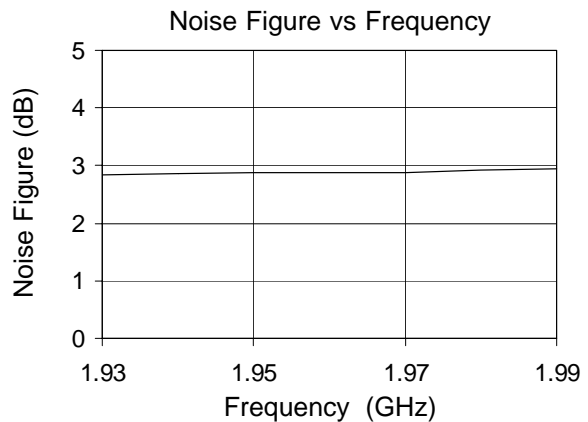
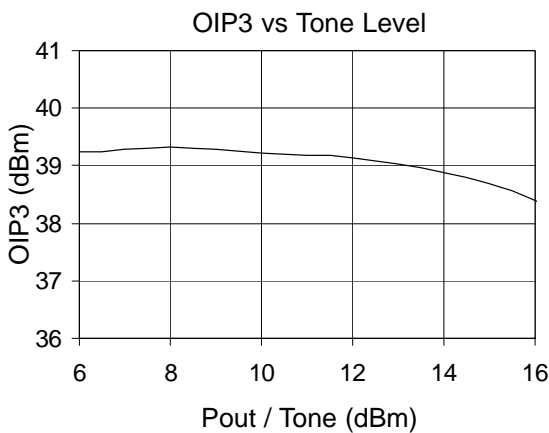
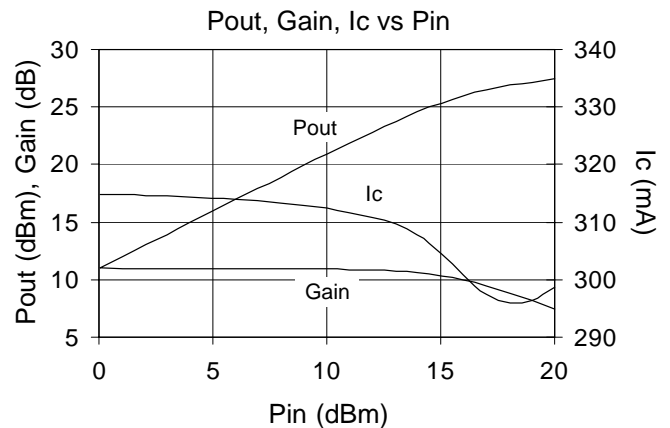
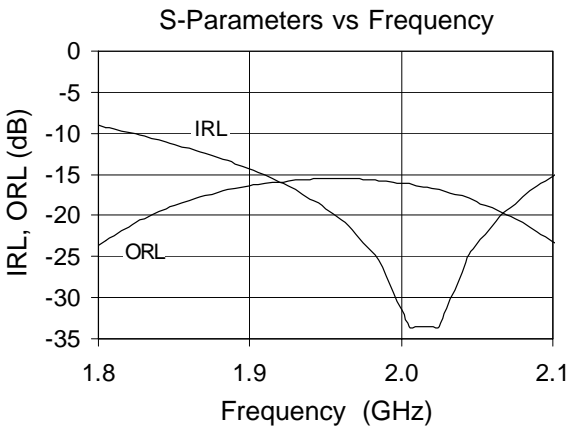
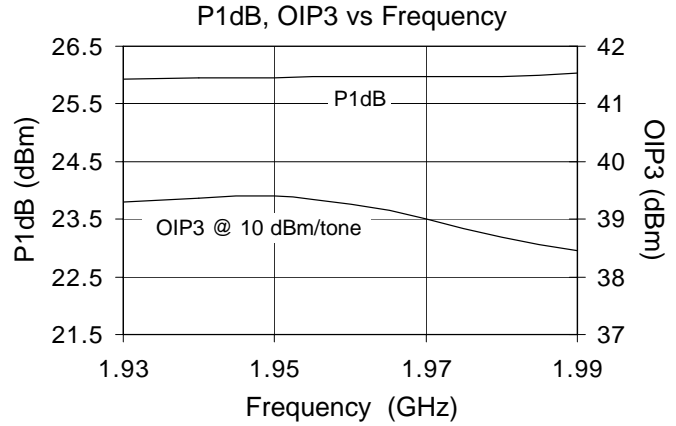
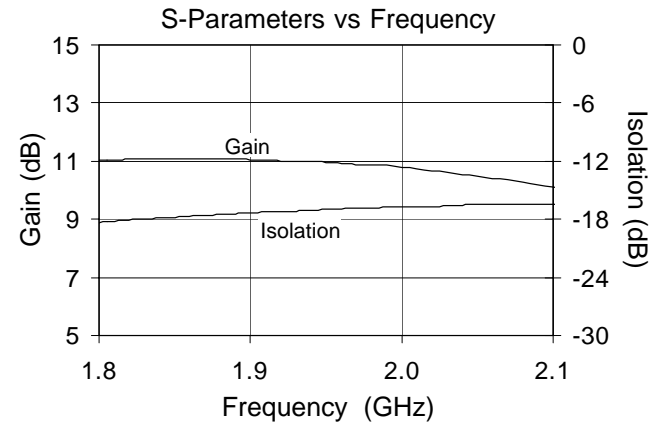

Freq (GHz)	P1dB (dBm)	OIP3 (dBm)	Gain (dB)	S11 (dB)	S22 (dB)	NF (dB)
1.93	25.9	39.3	11.1	-16.9	-15.7	2.8
1.96	26.0	39.3	11.0	-20.5	-15.5	2.9
1.99	26.0	38.4	10.9	-27.4	-15.9	2.9

1930-1990 MHz Application Circuit ($V_{CE}=5V, I_{CQ}=340mA, 25^{\circ}C$)

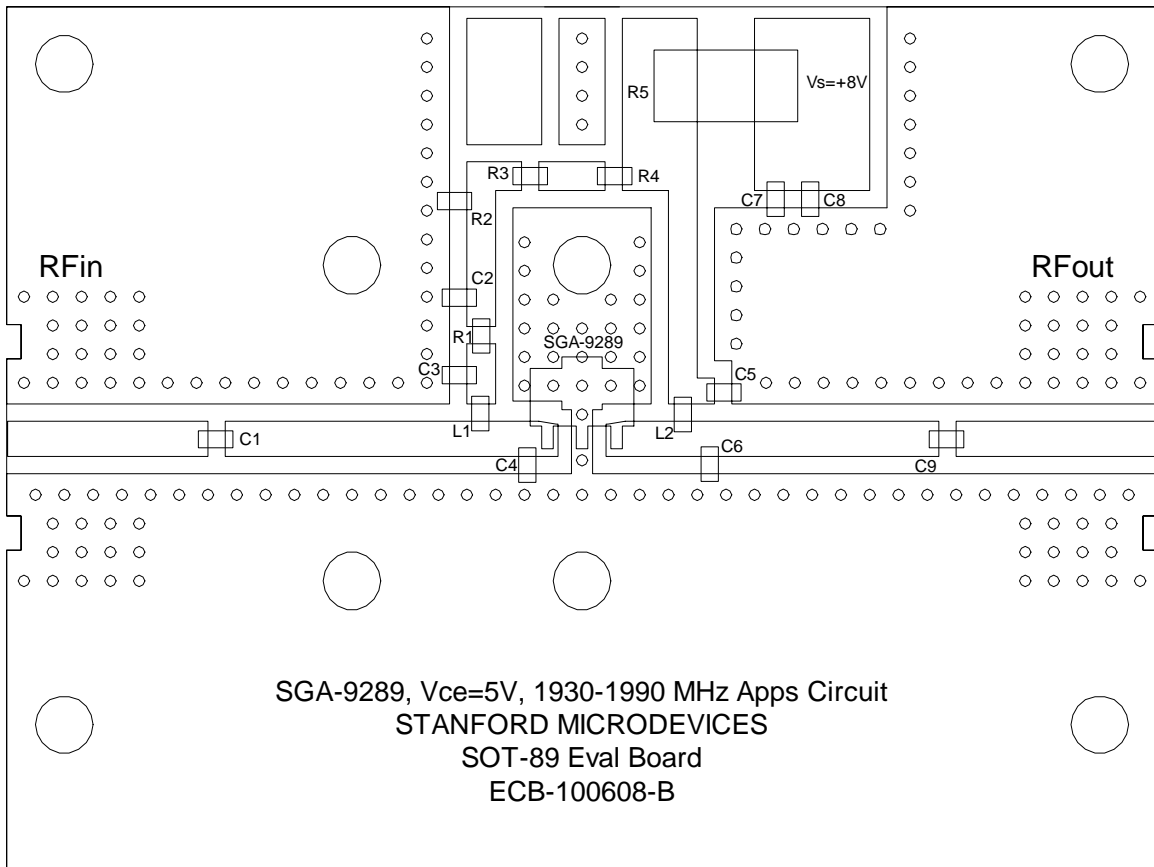

Ref Des.	Value	Part Number
C 1,3,5,9	12 pF	Rohm MCH18 series
C 2,7	0.1 uF	Rohm MCH18 series
C 4	2.7 pF	Rohm MCH18 series
C 6	1.8 pF	Rohm MCH18 series
C 8	1000 pF	Rohm MCH18 series
L 1,2	22 nH	TOKO LL1608 series
R 1	10 ohms	Rohm MCH18 series
R 2	51 ohms	Rohm MCH18 series
R 3	16 ohms	Rohm MCH18 series
R 4	240 ohms	Rohm MCH18 series
R 5	16 ohms	2512 pkg 1 WATT
R 6	18 ohms	2512 pkg 1 WATT

Ref. Des.	Value
Z1	50 Ohms, 47.1 deg. @ 1960 MHz
Z2	50 Ohms, 7 deg. @ 1960 MHz
Z3	50 Ohms, 7.2 deg. @ 1960 MHz
Z4	50 Ohms, 14.3 deg. @ 1960 MHz
Z5	50 Ohms, 4.8 deg. @ 1960 MHz
Z6	50 Ohms, 42.2 deg. @ 1960 MHz

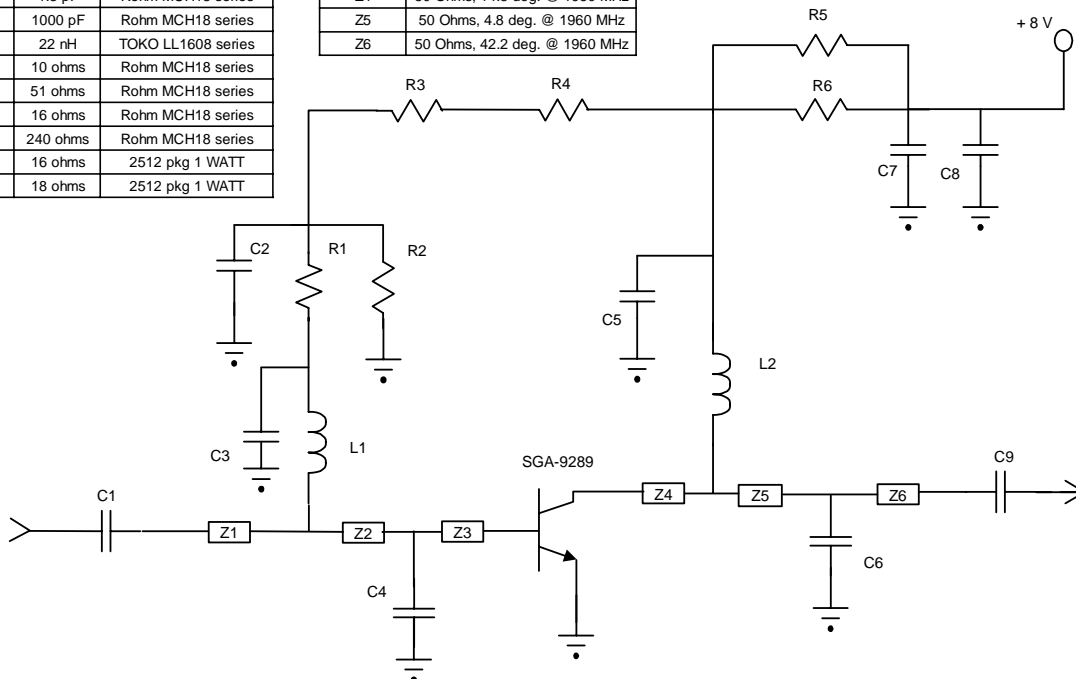

Typical Performance - 1930-1990 MHz Application Circuit ($V_{CE}=5V, I_{CQ}=340mA, 25^{\circ}C$)

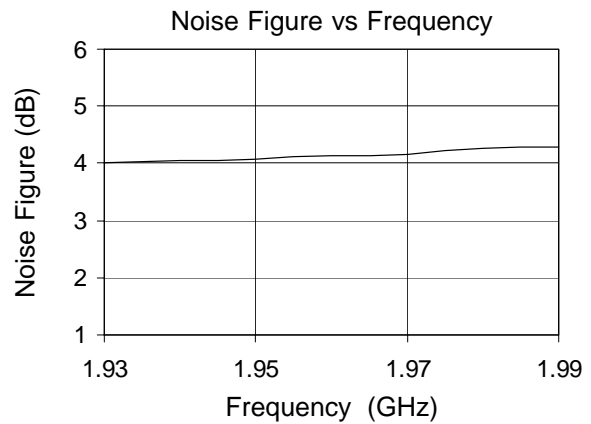
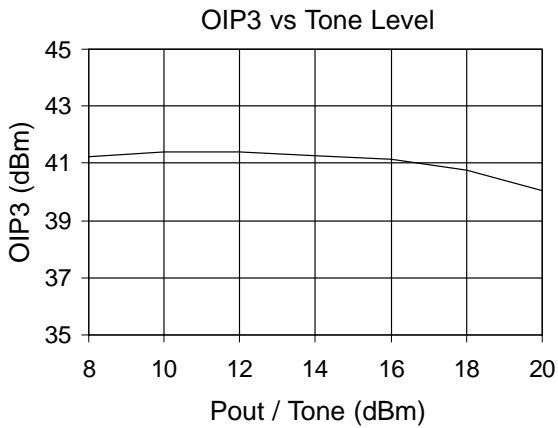
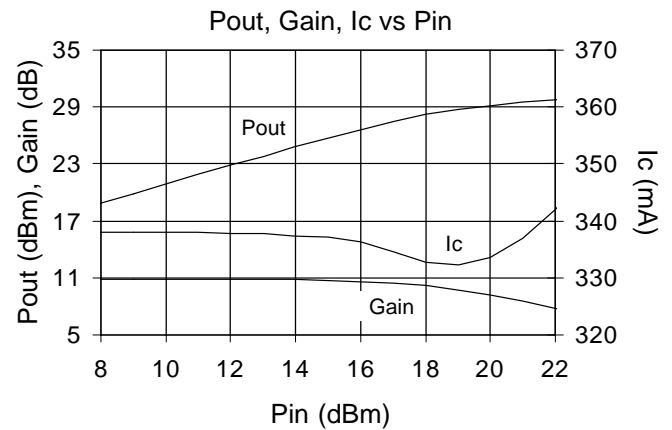
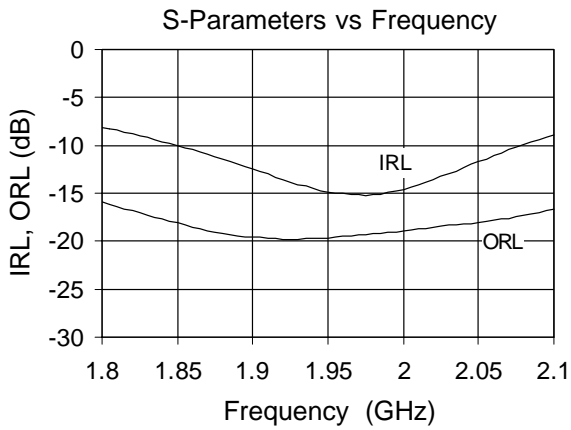
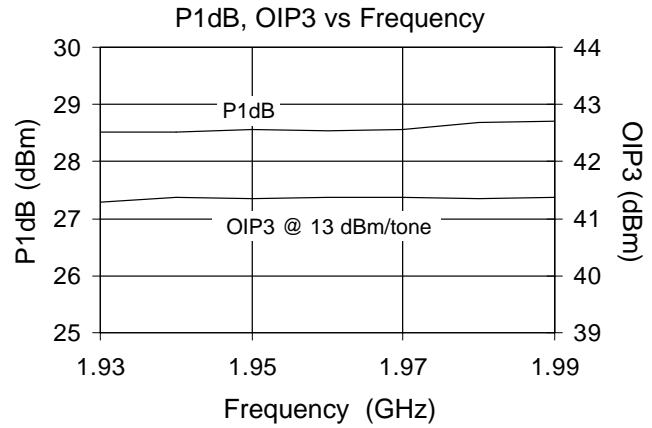
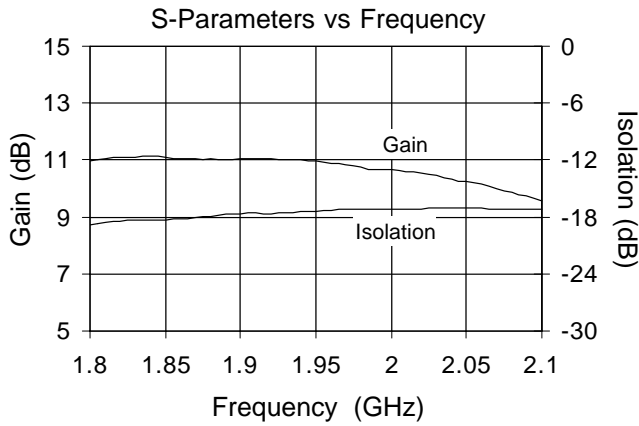

Freq (GHz)	P1dB (dBm)	OIP3 (dBm)	Gain (dB)	S11 (dB)	S22 (dB)	NF (dB)
1.93	28.5	41.3	11.1	-14.1	-19.8	4.0
1.96	28.5	41.4	10.9	-15.1	-19.5	4.1
1.99	28.7	41.4	10.7	-14.9	-19.1	4.3