

## Product Description

Stanford Microdevices' SPA-1318 is a high efficiency GaAs Heterojunction Bipolar Transistor (HBT) amplifier housed in a low-cost surface-mountable plastic package. These HBT amplifiers are fabricated using molecular beam epitaxial growth technology which produces reliable and consistent performance from wafer to wafer and lot to lot.

This product is specifically designed for use as a driver amplifier for infrastructure equipment in the 2150 MHz PCS band. Its high linearity makes it an ideal choice for multi-carrier and digital applications.

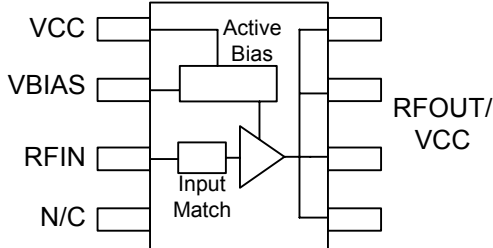

## SPA-1318

### 2150 MHz 1 Watt Power Amplifier with Active Bias

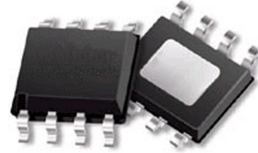

### Product Features

- On-chip Active Bias Control
- Power Control Allows Power Consumption Reduction
- Patented High Reliability GaAsHBT Technology
- High Linearity Performance: +48dBm OIP3 Typ.
- Surface-Mountable Plastic Package

### Applications

- W-CDMA Systems
- Multi-Carrier Applications

Symbol	Parameters: Test Conditions: $Z_0 = 50 \text{ Ohms}$ Temp = 25°C, Vcc = 5.0V	Units	Min.	Typ.	Max.
$f_0$	Frequency of Operation	MHz	2110		2170
$P_{1dB}$	Output Power at 1dB Compression	dBm		29.5	
$S_{21}$	Small Signal Gain	dB		11.5	
VSWR	Input VSWR	-		1.4:1	
$OIP_3$	Output Third Order Intercept Point Power out per tone = +14dBm	dBm		48.0	
icc	Device Current	mA		320	
$R_{th, j-l}$	Thermal Resistance (junction - lead)	°C/W		40	

The information provided herein is believed to be reliable at press time. Stanford Microdevices assumes no responsibility for inaccuracies or omissions. Stanford Microdevices assumes no responsibility for the use of this information, and all such information shall be entirely at the user's own risk. Prices and specifications are subject to change without notice. No patent rights or licenses to any of the circuits described herein are implied or granted to any third party. Stanford Microdevices does not authorize or warrant any Stanford Microdevices product for use in life-support devices and/or systems. Copyright 2001 Stanford Microdevices, Inc. All worldwide rights reserved.

### 2150 MHz Application Circuit Data, $I_{cc}=320mA$ , $T=+25C$ , $V_{cc}=5V$

Note: Tuned for Output IP3

**Input/Output Return Loss,  
Isolation vs Frequency**

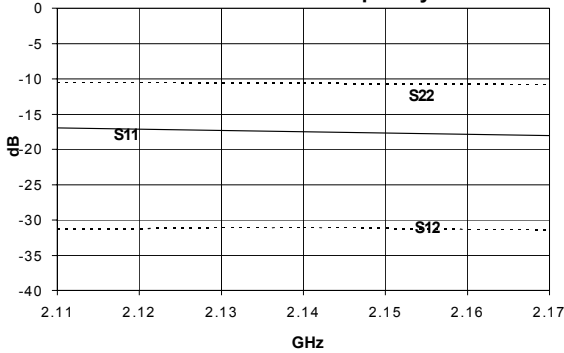

**Gain vs. Frequency**

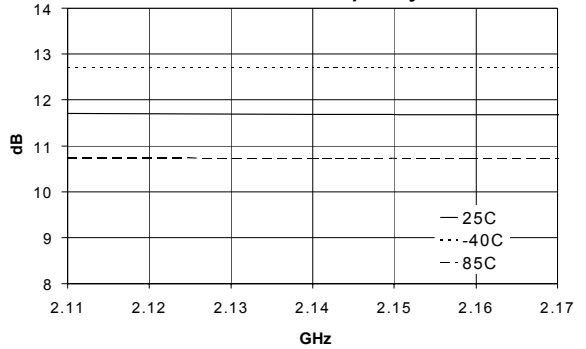

**P1dB vs Frequency**

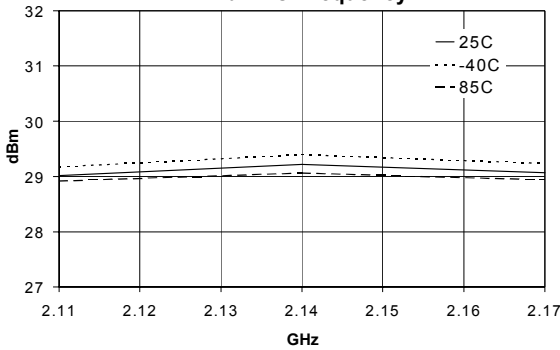

**OIP3 vs. Frequency  
( $P_{OUT}$  per tone = 14dBm)**

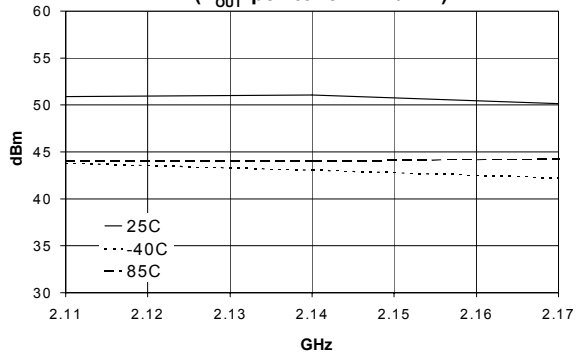

**OIP3 vs Tone Power  
2.14 GHz**

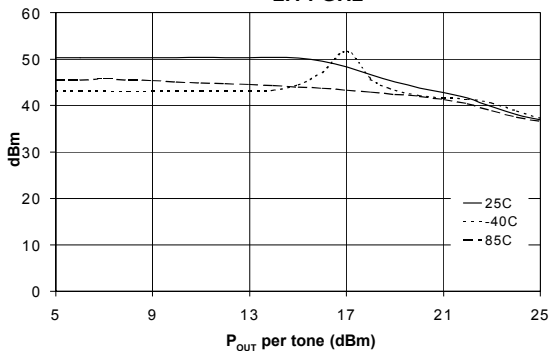

**Device Current vs. Source Voltage**

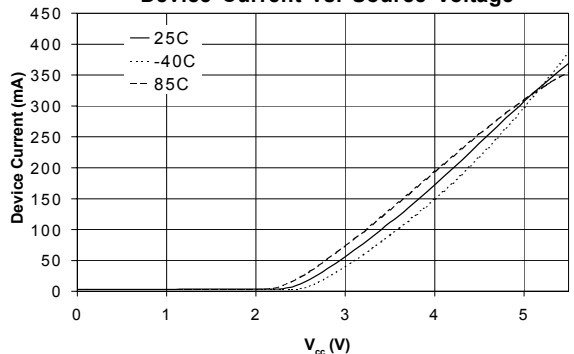

850-950 MHz Application Circuit Data (Optimized for IP3),  $I_{cc}=400\text{mA}$ ,  $T=+25\text{C}$ ,  $V_{cc}=5\text{V}$ ,  
 The W-CDMA setup is PCCPCH+PSCH+SSCH+CPICH+PICH+64 DPCH

**W-CDMA at 2.14 GHz**  
**Adjacent Channel Power**  
**vs. Channel Output Power**

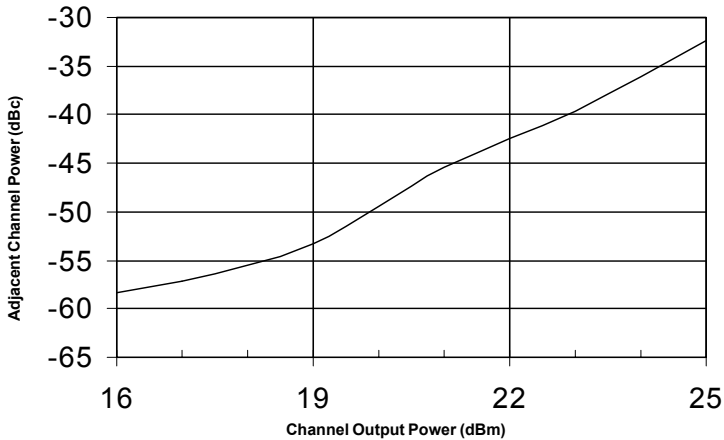

**W-CDMA at 2.14 GHz**

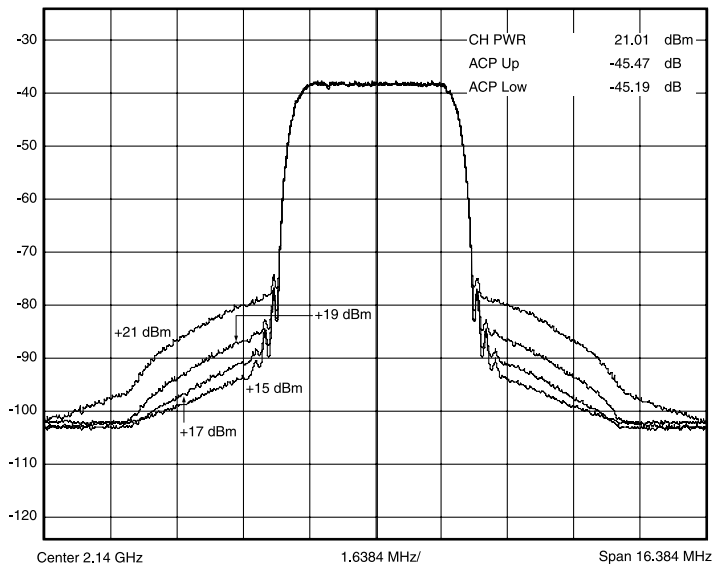

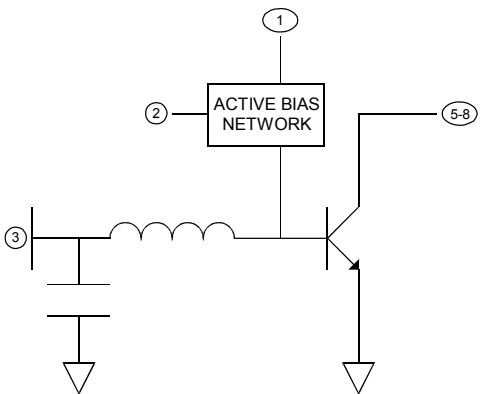

Pin #	Function	Description	Device Schematic
1	Vcc	VCC is the supply voltage for the active bias network. Bypassing in the appropriate location as shown on application schematic is required for optimum RF performance.	
2	Vbias	Vbias is the bias control pin for the active bias network. Device current is set by the current into this pin. Recommended configuration shown in the Application Schematic is required for optimum RF performance.	
3	RF In	RF input pin. This pin requires the use of an external DC blocking capacitor.	
4	N/C	No connection	
5, 6, 7, 8	RF Out/Vcc	RF output and bias pin. Bias should be supplied to this pin through an external RF choke. Because DC biasing is present on this pin, a DC blocking capacitor should be used in most applications (see application schematic). The supply side of the bias network should be well bypassed. An output matching network is necessary for optimum performance.	
EPAD	Gnd	Exposed area on the bottom side of the package needs to be soldered to the ground plane of the board for optimum thermal and RF performance. Several vias should be located under the EPAD as shown in the recommended land pattern (page 6).	

### Absolute Maximum Ratings

Operation of this device above any one of these parameters may cause permanent damage.

Bias Conditions should also satisfy the following expression:  $I_D V_D (\text{max}) < (T_J - T_{OP}) / R_{th(j-c)}$

Parameter	Value	Unit
Supply Current ( $I_b$ )	750	mA
Device Voltage ( $V_D$ )	6.0	V
Power Dissipation	4.0	W
Operating Lead Temperature ( $T_L$ )	-40 to +85	°C
RF Input Power	800	mW
Storage Temperature Range	-40 to +150	°C
Operating Junction Temperature ( $T_J$ )	+150	°C



**Caution: ESD sensitive**

Appropriate precautions in handling, packaging and testing devices must be observed.

**Preliminary**  
**SPA-1318 2150 MHz 1 Watt Power Amp.**

**Part Number Ordering Information**

Part Number	Devices Per Reel	Reel Size
SPA-1318	500	7"

**Package Outline Drawing**

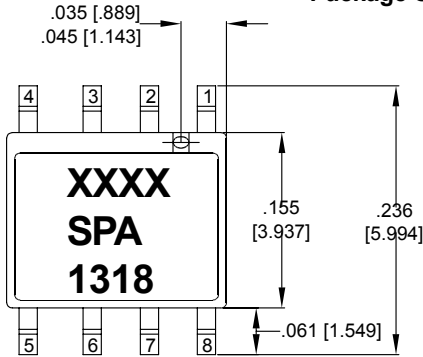

TOP VIEW

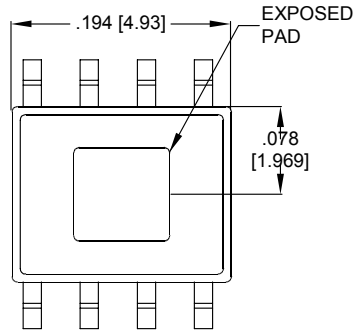

BOTTOM VIEW

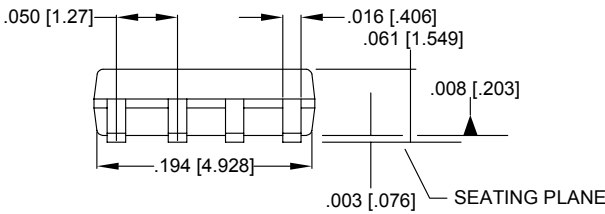

SIDE VIEW

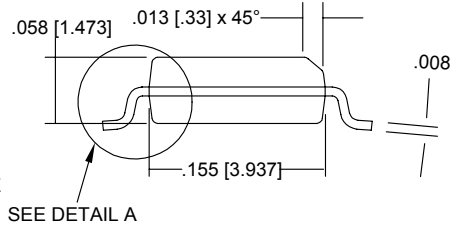

END VIEW

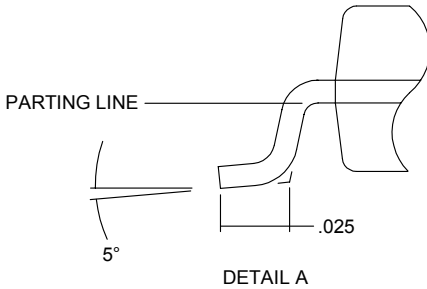

DETAIL A

**Recommended Land Pattern**

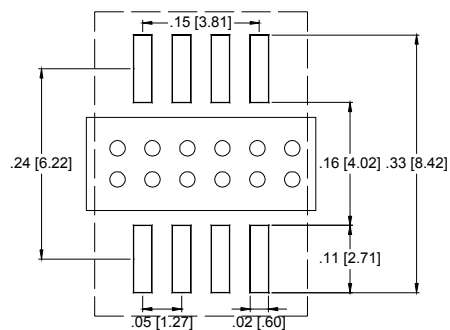

**Note:** XXXX represents the lot code



**Note:** Parts need to be baked prior to use as discussed in application note AN-029 (Special handling information for Exposed Pad™ SOIC-8 products) to ensure no moisture is trapped in the encapsulated package. In production, this baking procedure is not necessary if parts are used within 48 hours of opening the sealed shipping materials.