

RELIABILITY REPORT
FOR
LMX321AxK
PLASTIC ENCAPSULATED DEVICES

May 26, 2002

MAXIM INTEGRATED PRODUCTS

120 SAN GABRIEL DR.
SUNNYVALE, CA 94086

Written by



Jim Pedicord
Quality Assurance
Reliability Lab Manager

Reviewed by



Bryan J. Preeshl
Quality Assurance
Executive Director

Conclusion

The LMX321 successfully meets the quality and reliability standards required of all Maxim products. In addition, Maxim's continuous reliability monitoring program ensures that all outgoing product will continue to meet Maxim's quality and reliability standards.

Table of Contents

I.Device Description	V.Quality Assurance Information
II.Manufacturing Information	VI.Reliability Evaluation
III.Packaging Information	
IV.Die InformationAttachments

I. Device Description

A. General

The LMX321 is a single, low-cost, low-voltage, pin-to-pin compatible upgrade to the LMV321 general-purpose op amp. This device offers Rail-to-Rail® outputs and an input common-mode range that extends below ground. This op amp draws only 105µA of quiescent current per amplifier, operates from a single +2.3V to +7V supply, and drives 2kΩ resistive loads to within 40mV of either rail. The LMX321 is unity-gain stable with a 1.3MHz gain-bandwidth product capable of driving capacitive loads up to 400pF. The combination of low voltage, low cost, and small package size makes this amplifier ideal for portable/battery-powered equipment.

The LMX321 single op amp is available in ultra-small 5-pin SC70 and space-saving 5-pin SOT23 packages.

B. Absolute Maximum Ratings

<u>Item</u>	<u>Rating</u>
Supply Voltage (V_{CC} to V_{EE})	-0.3V to +8V
Differential Input Voltage (V_{IN+} - V_{IN-})	V_{EE} to V_{CC}
OUT_{-} to V_{EE}	-0.3V to ($V_{CC} + 0.3V$)
Short-Circuit Duration (OUT_{-} shorted to V_{CC} or V_{EE})	Continuous
Continuous Power Dissipation ($T_A = +70^{\circ}C$)	
Storage Temp.	-65°C to +150°C
Junction Temperature	+150°C
Lead Temp. (10 sec.)	+300°C
Power Dissipation	
5 Lead SOT23	571mW
5 Lead SC70	247mW
Derates above +70°C	
5 Lead SOT-23	7.1mW/°C
5 Lead SC70	3.1mW/°C

II. Manufacturing Information

A. Description/Function:	Single, General Purpose, Low-Voltage, Rail-to-Rail Op Amp
B. Process:	CB20 (High Speed Complementary Bipolar Process)
C. Number of Device Transistors:	88
D. Fabrication Location:	Oregon, USA
E. Assembly Location:	Philippines, Malaysia or Thailand
F. Date of Initial Production:	July, 2001

III. Packaging Information

A. Package Type:	5 Lead SOT-23	5-Lead SC70
B. Lead Frame:	Copper	Alloy 42
C. Lead Finish:	Solder Plate	Solder Plate
D. Die Attach:	Silver-filled Epoxy	Silver-filled Epoxy
E. Bondwire:	Gold (1 mil dia.)	Gold (1 mil dia.)
F. Mold Material:	Epoxy with silica filler	Epoxy with silica filler
G. Assembly Diagram:	Buildsheet # 05-2501-0167	Buildsheet # 05-2501-0168
H. Flammability Rating:	Class UL94-V0	Class UL94-V0
I. Classification of Moisture Sensitivity per JEDEC standard JESD22-A112:	Level 1	

IV. Die Information

A. Dimensions:	31 x 30 mils
B. Passivation:	Si ₃ N ₄ /SiO ₂ (Silicon nitride/ Silicon dioxide)
C. Interconnect:	Gold
D. Backside Metallization:	None
E. Minimum Metal Width:	2 microns (as drawn)
F. Minimum Metal Spacing:	2 microns (as drawn)
G. Bondpad Dimensions:	5 mil. Sq.
H. Isolation Dielectric:	SiO ₂
I. Die Separation Method:	Wafer Saw

Table 1
Reliability Evaluation Test Results

LMX321AxK

TEST ITEM	TEST CONDITION	FAILURE IDENTIFICATION	PACKAGE	SAMPLE SIZE	NUMBER OF FAILURES
Static Life Test (Note 1)					
	Ta = 135°C Biased Time = 192 hrs.	DC Parameters & functionality		79	0
Moisture Testing (Note 2)					
Pressure Pot	Ta = 121°C P = 15 psi. RH= 100% Time = 168hrs.	DC Parameters & functionality	SC70	77	0
			SOT23	99	0
85/85	Ta = 85°C RH = 85% Biased Time = 1000hrs.	DC Parameters & functionality		77	0
Mechanical Stress (Note 2)					
Temperature Cycle	-65°C/150°C 1000 Cycles Method 1010	DC Parameters		77	0

Note 1: Life Test Data may represent plastic D.I.P. qualification lots for the package.

Note 2: Generic package/process data

TABLE II. Pin combination to be tested. 1/ 2/

	Terminal A (Each pin individually connected to terminal A with the other floating)	Terminal B (The common combination of all like-named pins connected to terminal B)
1.	All pins except V_{PS1} 3/	All V_{PS1} pins
2.	All input and output pins	All other input-output pins

1/ Table II is restated in narrative form in 3.4 below.

2/ No connects are not to be tested.

3/ Repeat pin combination 1 for each named Power supply and for ground

(e.g., where V_{PS1} is V_{DD} , V_{CC} , V_{SS} , V_{BB} , GND, $+V_S$, $-V_S$, V_{REF} , etc).

3.4 Pin combinations to be tested.

- a. Each pin individually connected to terminal A with respect to the device ground pin(s) connected to terminal B. All pins except the one being tested and the ground pin(s) shall be open.
- b. Each pin individually connected to terminal A with respect to each different set of a combination of all named power supply pins (e.g., V_{SS1} , or V_{SS2} or V_{SS3} or V_{CC1} , or V_{CC2}) connected to terminal B. All pins except the one being tested and the power supply pin or set of pins shall be open.
- c. Each input and each output individually connected to terminal A with respect to a combination of all the other input and output pins connected to terminal B. All pins except the input or output pin being tested and the combination of all the other input and output pins shall be open.

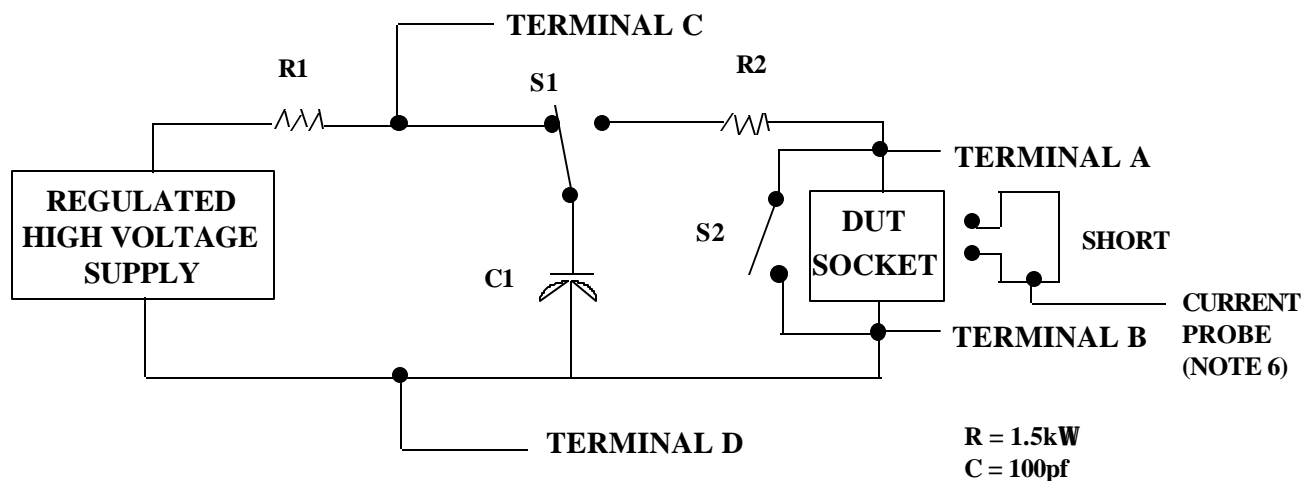

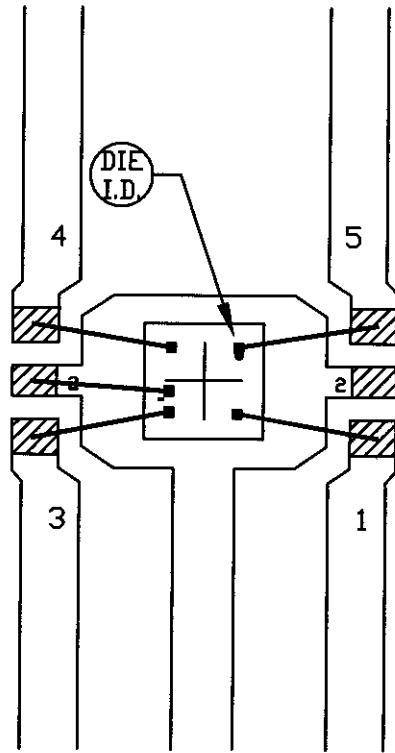

▨ - BONDING AREA

NOTE: CAVITY DOWN

PKG. CODE: U5-1		SIGNATURES	DATE	MAXIM CONFIDENTIAL & PROPRIETARY
CAV./PAD SIZE: 64X45	PKG. DESIGN			BOND DIAGRAM #: 05-2501-0167
				REV: A

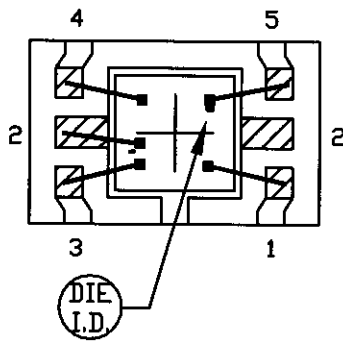

▨ BONDABLE AREA

NOTE: CAVITY DOWN

PKG. CODE: X5-1		SIGNATURES <i>h</i>	DATE /	 CONFIDENTIAL & PROPRIETARY	
CAV./PAD SIZE: 35x34	PKG. DESIGN			BOND DIAGRAM #: 05-2501-0168	REV: A

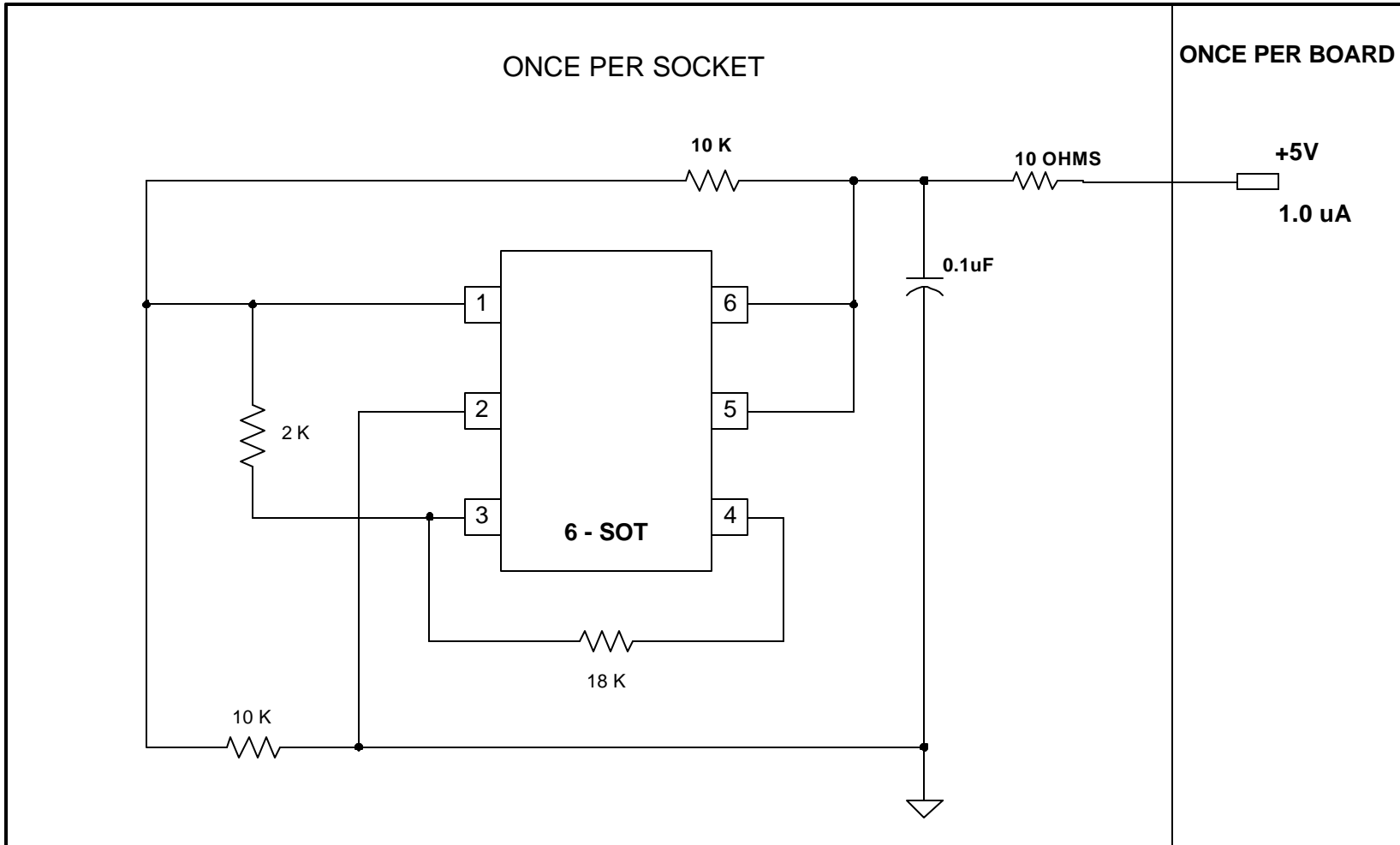

DEVICES: MAX 4464/4470/4400/4401/4480/4481/
 4490/4291/4465/4466/4335/4336/4245/LMX321/4231
 MAX CURRENT: MAX4481/MAX4291/LMX321= 800uA / MAX4464/4470/
 4480/4465/4466= 400uA / MAX4400/4401/4245=1.2mA / MAX4490=2.5mA
 MAX4435/4436/4231/4230=3.4mA

DRAWN BY: