



Dual, Quad, and Hex High-Speed Differential ESD-Protection ICs

General Description

The MAX3205E/MAX3207E/MAX3208E low-capacitance, $\pm 15\text{kV}$ ESD-protection diode arrays with an integrated transient voltage suppressor (TVS) clamp are suitable for high-speed and general-signal ESD protection. Low input capacitance makes these devices ideal for ESD protection of signals in HDTV, PC monitors (DVI™, HDMI™), PC peripherals (FireWire®, USB 2.0), server interconnect (PCI Express™, Infiniband®), datacom, and interchassis interconnect. Each channel consists of a pair of diodes that steer ESD current pulses to V_{CC} or GND.

The MAX3205E/MAX3207E/MAX3208E protect against ESD pulses up to $\pm 15\text{kV}$ Human Body Model, $\pm 8\text{kV}$ Contact Discharge, and $\pm 15\text{kV}$ Air-Gap Discharge, as specified in IEC 61000-4-2. An integrated TVS ensures that the voltage rise seen on V_{CC} during an ESD event is clamped to a known voltage. These devices have a 2pF input capacitance per channel, and a channel-to-channel capacitance variation of only 0.05pF, making them ideal for use on high-speed, single-ended, or differential signals.

The MAX3207E is a two-channel device suitable for USB 1.1, USB 2.0 (480Mbps), and USB OTG applications. The MAX3208E is a four-channel device for Ethernet and FireWire applications. The MAX3205E is a six-channel device for cell phone connectors and SVGA video connections.

The MAX3205E is available in 9-bump, tiny chip-scale (UCSP™), and 16-pin, 3mm x 3mm, thin QFN packages. The MAX3207E is available in a small 6-pin SOT23 package. The MAX3208E is available in 10-pin μMAX ® and 16-pin, 3mm x 3mm TQFN packages. All devices are specified for the -40°C to $+125^\circ\text{C}$ automotive operating temperature range.

Applications

- DVI Input/Output Protection
- Set-Top Boxes
- PDAs/Cell Phones
- Graphics Controller Cards
- Displays/Projectors
- High-Speed, Full-Speed and Low-Speed USB Port Protection
- FireWire IEEE 1394 Ports
- Consumer Equipment
- High-Speed Differential Signal Protection

Typical Operating Circuit and Pin Configurations appear at end of data sheet.



Features

- ◆ Low Input Capacitance of 2pF Typical
- ◆ Low Channel-to-Channel Variation of 0.05pF from I/O to I/O
- ◆ High-Speed Differential or Single-Ended ESD Protection
 - ±15kV–Human Body Model
 - ±8kV–IEC 61000-4-2, Contact Discharge
 - ±15kV–IEC 61000-4-2, Air-Gap Discharge
- ◆ Integrated Transient Voltage Suppressor (TVS)
- ◆ Optimized Pinout for Minimized Stub Instances on Controlled-Impedance Differential-Transmission Line Routing
- ◆ -40°C to $+125^\circ\text{C}$ Automotive Operating Temperature Range
- ◆ UCSP Packaging Available

Ordering Information

PART	TEMP RANGE	PIN-PACKAGE	PKG CODE
MAX3205EABL-T	-40°C to $+125^\circ\text{C}$	9 UCSP-9	B9-2
MAX3205EATE	-40°C to $+125^\circ\text{C}$	16 TQFN-EP* (3mm x 3mm)	T1633-4
MAX3207EAUT-T	-40°C to $+125^\circ\text{C}$	6 SOT23-6	U6-1
MAX3208EAUB	-40°C to $+125^\circ\text{C}$	10 μMAX	U10-2
MAX3208EATE	-40°C to $+125^\circ\text{C}$	16 TQFN-EP* (3mm x 3mm)	T1633-4

*EP = Exposed pad.

FireWire is a registered trademark of Apple Computer, Inc.

PCI Express is a trademark of PCI-SIG Corporation.

DVI is a trademark of Digital Display Working Group.

HDMI is a trademark of HDMI Licensing, LCC.

InfiniBand is a registered trademark of InfiniBand Trade Association.

UCSP is a trademark and μMAX is a registered trademark of Maxim Integrated Products, Inc.

Selector Guide

PART	ESD-PROTECTED I/O PORTS	TOP MARK
MAX3205EABL-T	6	AES
MAX3205EATE	6	ACO
MAX3207EAUT-T	2	ABVG
MAX3208EAUB	4	—
MAX3208EATE	4	ACN

Dual, Quad, and Hex High-Speed Differential ESD-Protection ICs

ABSOLUTE MAXIMUM RATINGS

V _{CC} to GND	-0.3V to +6.0V	Operating Temperature Range	-40°C to +125°C
I/O ₋ to GND	-0.3V to (V _{CC} + 0.3V)	Storage Temperature Range	-65°C to +150°C
Continuous Power Dissipation (T _A = +70°C)		Junction Temperature	+150°C
6-Pin SOT23 (derate 8.7mW/°C above +70°C).....	696mW	Lead Temperature (soldering, 10s)	+300°C
9-Pin UCSP (derate 4.7mW/°C above +70°C)	379mW	Bump Temperature (soldering)	
10-Pin μMAX (derate 5.6mW/°C above +70°C)	444mW	Infrared (15s)	+220°C
16-Pin Thin QFN (derate 20.8mW/°C above +70°C) .	1667mW	Vapor Phase (60s)	+215°C

Stresses beyond those listed under "Absolute Maximum Ratings" may cause permanent damage to the device. These are stress ratings only, and functional operation of the device at these or any other conditions beyond those indicated in the operational sections of the specifications is not implied. Exposure to absolute maximum rating conditions for extended periods may affect device reliability.

ELECTRICAL CHARACTERISTICS

(V_{CC} = +5V, T_A = T_{MIN} to T_{MAX}, unless otherwise noted. Typical values are at V_{CC} = +5V and T_A = +25°C.) (Note 1)

PARAMETER	SYMBOL	CONDITIONS	MIN	TYP	MAX	UNITS
Supply Voltage	V _{CC}		0.9		5.5	V
Supply Current	I _{CC}			1	100	nA
Diode Forward Voltage	V _F	I _F = 10mA	0.65		0.95	V
Channel Clamp Voltage (Note 2)	V _C	T _A = +25°C, ±15kV Human Body Model, I _F = 10A	Positive transients		V _{CC} + 25	V
			Negative transients		-25	
		T _A = +25°C, ±8kV Contact Discharge (IEC 61000-4-2), I _F = 24A	Positive transients		V _{CC} + 60	
			Negative transients		-60	
		T _A = +25°C, ±15kV Air-Gap Discharge (IEC 61000-4-2), I _F = 45A	Positive transients		V _{CC} + 100	
			Negative transients		-100	
Channel Leakage Current			-0.1		+0.1	μA
Channel I/O Capacitance		V _{CC} = +3.3V, bias of V _{CC} / 2	MAX3205EABL-T MAX3207EAUT	2.5	3	pF
			MAX3205EATE MAX3208EATE	2.7	3.2	
			MAX3208EAUB	2.6	3.1	
Channel I/O to I/O Variation in Capacitance	ΔC _{IN}	V _{CC} = +3.3V, bias of V _{CC} / 2, C _{I/O-} to GND		±0.05		pF
TRANSIENT SUPPRESSOR						
V _{CC} Capacitance to GND				10		pF
ESD Trigger Voltage		dV/dt ≤ 1V/ns (Note 3)		9		V

Note 1: Parameters are 100% production tested at +25°C. Limits over temperature are guaranteed by design only.

Note 2: Idealized clamp voltages. See the *Applications Information* section for more information.

Note 3: Guaranteed by design, not production tested.

Dual, Quad, and Hex High-Speed Differential ESD-Protection ICs

Typical Operating Characteristics

($V_{CC} = +5V$, $T_A = +25^\circ C$, unless otherwise noted.)

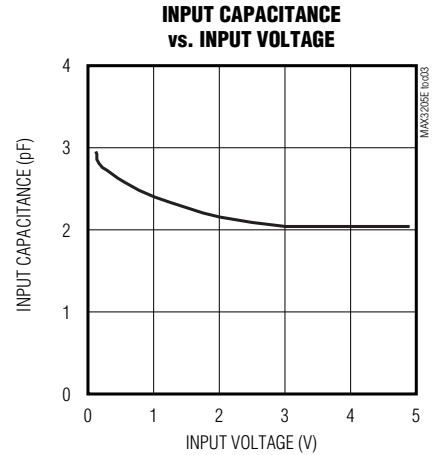
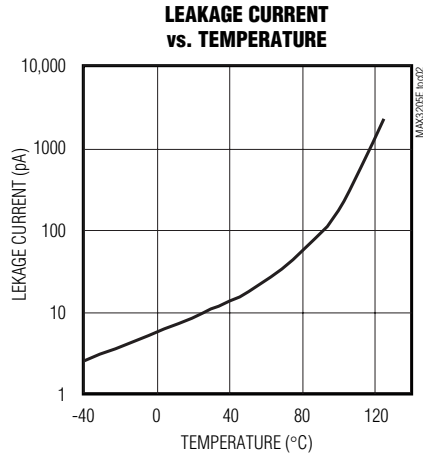
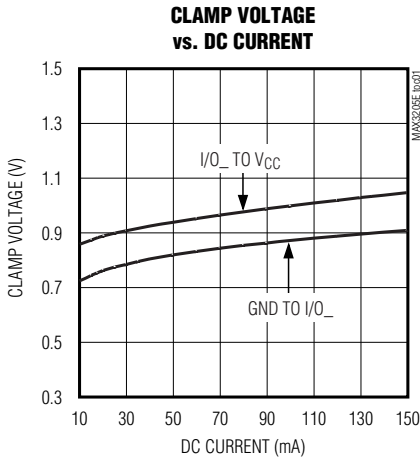

Pin Description

PIN					NAME	FUNCTION
MAX3205E		MAX3207E	MAX3208E			
TQFN	UCSP	SOT23	μMAX	TQFN		
4, 5, 7, 12, 13, 15	A2, A3, B1, B3, C1, C2	1, 4	1, 4, 6, 9	4, 7, 12, 15	I/O_	ESD-Protected Channel
1, 3, 6, 8, 9, 11, 14, 16	—	3, 6	2, 5, 7, 10	1, 3, 5, 6, 8, 9, 11, 13, 14, 16	N.C.	No Connection. Not internally connected.
—	B2	—	—	—	N.C.	No Connection. The solder sphere is omitted from this location (see the <i>Packaging Information</i> section).
2	A1	2	3	2	GND	Ground. Connect GND with a low-impedance connection to the ground plane.
10	C3	5	8	10	V _{CC}	Power-Supply Input. Bypass V _{CC} to GND with a 0.1μF ceramic capacitor as close to the device as possible.
EP	—	—	—	EP	EP	Exposed Pad. Connect EP to GND.

Dual, Quad, and Hex High-Speed Differential ESD-Protection ICs

Detailed Description

The MAX3205E/MAX3207E/MAX3208E low-capacitance, $\pm 15\text{kV}$ ESD-protection diode arrays with an integrated transient voltage suppressor (TVS) clamp are suitable for high-speed and general-signal ESD protection. Low input capacitance makes these devices ideal for ESD protection of signals in HDTV, PC monitors (DVI, HDMI), PC peripherals (FireWire, USB 2.0), Server Interconnect (PCI Express, Infiniband), Datacom, and Inter-Chassis Interconnect. Each channel consists of a pair of diodes that steer ESD current pulses to V_{CC} or GND. The MAX3205E, MAX3207E, and MAX3208E are two, four, and six channels (see the *Functional Diagram*).

The MAX3205E/MAX3207E/MAX3208E are designed to work in conjunction with a device's intrinsic ESD protection. The MAX3205E/MAX3207E/MAX3208E limit the

excursion of the ESD event to below $\pm 25\text{V}$ peak voltage when subjected to the Human Body Model waveform. When subjected to the IEC 61000-4-2 waveform, the peak voltage is limited to $\pm 60\text{V}$ when subjected to Contact Discharge. The peak voltage is limited to $\pm 100\text{V}$ when subjected to Air-Gap Discharge. The device protected by the MAX3205E/MAX3207E/MAX3208E must be able to withstand these peak voltages, plus any additional voltage generated by the parasitic of the board.

A TVS is integrated into the MAX3205E/MAX3207E/MAX3208E to help clamp ESD to a known voltage. This helps reduce the effects of parasitic inductance on the V_{CC} rail by clamping V_{CC} to a known voltage during an ESD event. For the lowest possible clamp voltage during an ESD event, placing a $0.1\mu\text{F}$ capacitor as close to V_{CC} as possible is recommended.

Functional Diagram

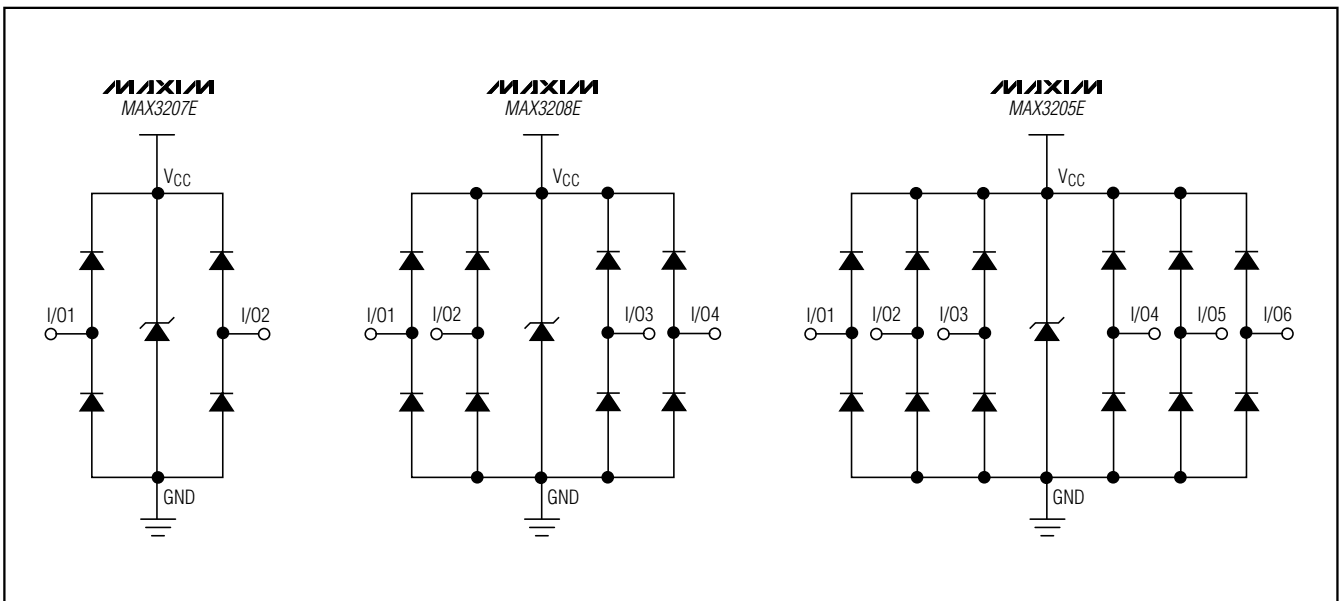

Dual, Quad, and Hex High-Speed Differential ESD-Protection ICs

MAX3205E/MAX3207E/MAX3208E

Applications Information

Design Considerations

Maximum protection against ESD damage results from proper board layout (see the *Layout Recommendations* section). A good layout reduces the parasitic series inductance on the ground line, supply line, and protected signal lines. The MAX3205E/MAX3207E/MAX3208E ESD diodes clamp the voltage on the protected lines during an ESD event and shunt the current to GND or VCC. In an ideal circuit, the clamping voltage (V_C) is defined as the forward voltage drop (V_F) of the protection diode, plus any supply voltage present on the cathode.

For positive ESD pulses:

$$V_C = V_{CC} + V_F$$

For negative ESD pulses:

$$V_C = -V_F$$

The effect of the parasitic series inductance on the lines must also be considered (Figure 1).

For positive ESD pulses:

$$V_C = V_{CC} + V_{F(D1)} + \left(L1 \times \frac{d(I_{ESD})}{dt} \right) + \left(L2 \times \frac{d(I_{ESD})}{dt} \right)$$

For negative ESD pulses:

$$V_C = - \left(V_{F(D2)} + \left(L1 \times \frac{d(I_{ESD})}{dt} \right) + \left(L3 \times \frac{d(I_{ESD})}{dt} \right) \right)$$

where, I_{ESD} is the ESD current pulse.

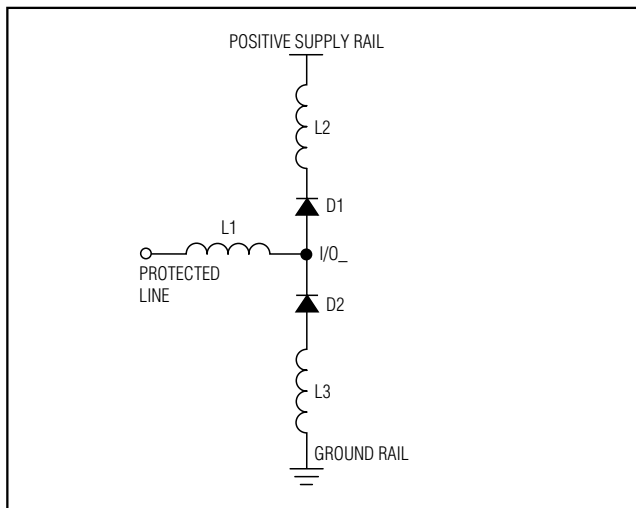

Figure 1. Parasitic Series Inductance

During an ESD event, the current pulse rises from zero to peak value in nanoseconds (Figure 2). For example, in a 15kV IEC-61000 Air-Gap Discharge ESD event, the pulse current rises to approximately 45A in 1ns ($di/dt = 45 \times 10^9$). An inductance of only 10nH adds an additional 450V to the clamp voltage, and represents approximately 0.5in of board trace. Regardless of the device's specified diode clamp voltage, a poor layout with parasitic inductance significantly increases the effective clamp voltage at the protected signal line. Minimize the effects of parasitic inductance by placing the MAX3205E/MAX3207E/MAX3208E as close to the connector (or ESD contact point) as possible.

A low-ESR 0.1 μ F capacitor is recommended between VCC and GND in order to get the maximum ESD protection possible. This bypass capacitor absorbs the charge transferred by a positive ESD event. Ideally, the supply rail (VCC) would absorb the charge caused by a positive ESD strike without changing its regulated value. All power supplies have an effective output impedance. All power supplies have an effective output impedance on their positive rails. If a power supply's effective output impedance is 1 Ω , then by using $V = I \times R$, the clamping voltage of V_C increases by the equation $V_C = I_{ESD} \times R_{OUT}$. A +8kV IEC 61000-4-2 ESD event generates a current spike of 24A. The clamping voltage increases by $V_C = 24A \times 1\Omega$, or $V_C = 24V$. Again, a poor layout without proper bypassing increases the clamping voltage. A ceramic chip capacitor mounted as close as possible to the MAX3205E/MAX3207E/MAX3208E VCC pin is the best choice for this application. A bypass capacitor should also be placed as close to the protected device as possible.

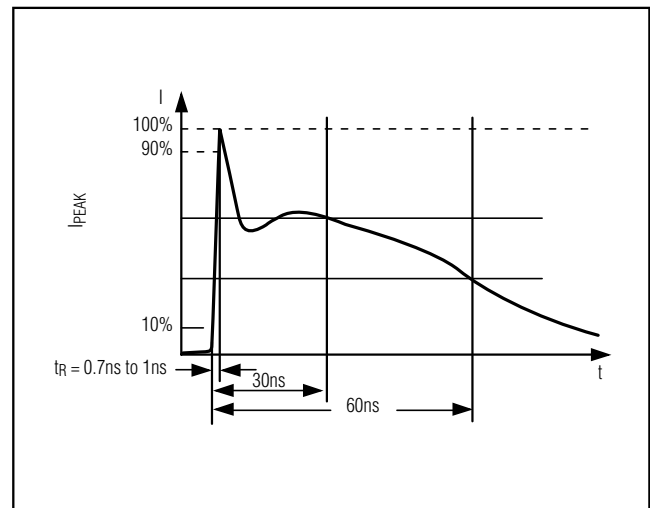

Figure 2. IEC 61000-4-2 ESD Generator Current Waveform

Dual, Quad, and Hex High-Speed Differential ESD-Protection ICs

±15kV ESD Protection

ESD protection can be tested in various ways. The MAX3205E/MAX3207E/MAX3208E are characterized for protection to the following limits:

- ±15kV using the Human Body Model
- ±8kV using the Contact Discharge Method specified in IEC 61000-4-2
- ±15kV using the IEC 61000-4-2 Air-Gap Discharge Method

ESD Test Conditions

ESD performance depends on a number of conditions. Contact Maxim for a reliability report that documents test setup, methodology, and results.

Human Body Model

Figure 3 shows the Human Body Model, and Figure 4 shows the current waveform it generates when discharged into a low impedance. This model consists of a 100pF capacitor charged to the ESD voltage of interest, which is then discharged into the device through a 1.5kΩ resistor.

IEC 61000-4-2

The IEC 61000-4-2 standard covers ESD testing and performance of finished equipment. The MAX3205E/MAX3207E/MAX3208E help users design equipment that meets Level 4 of IEC 61000-4-2. The main difference between tests done using the Human Body Model

and IEC 61000-4-2 is higher peak current in IEC 61000-4-2. Because series resistance is lower in the IEC 61000-4-2 ESD test model (Figure 5), the ESD-withstand voltage measured to this standard is generally lower than that measured using the Human Body Model. Figure 2 shows the current waveform for the ±8kV, IEC 61000-4-2 Level 4, ESD Contact Discharge test. The Air-Gap Discharge test involves approaching the device with a charged probe. The Contact Discharge method connects the probe to the device before the probe is energized.

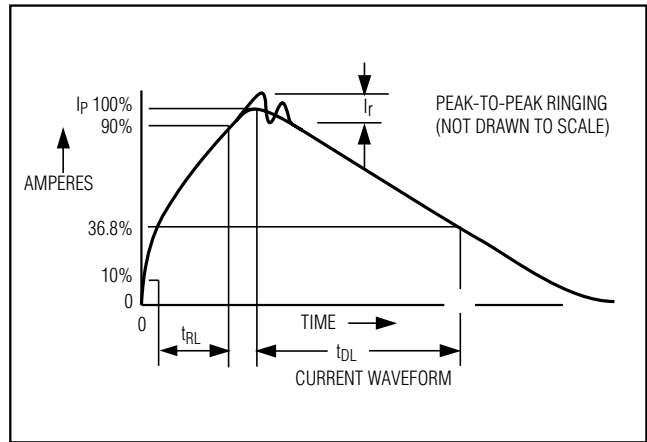

Figure 4. Human Body Model Current Waveform

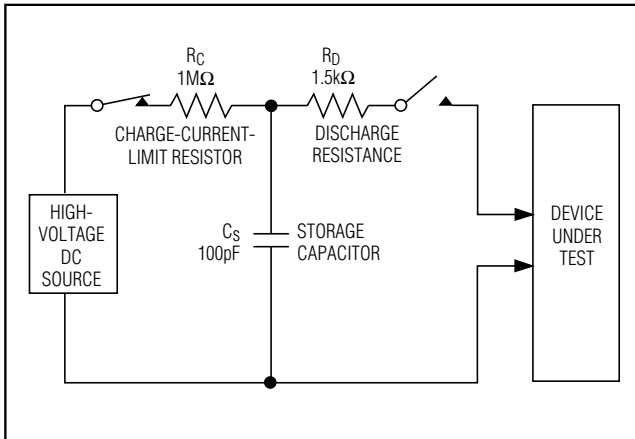

Figure 3. Human Body ESD Test Model

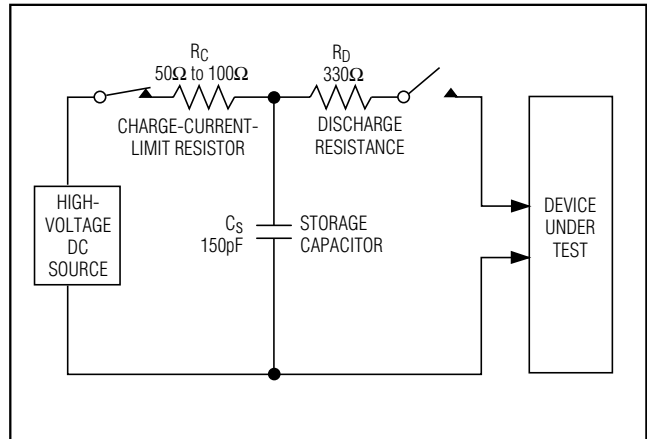

Figure 5. IEC 61000-4-2 ESD Test Model

Dual, Quad, and Hex High-Speed Differential ESD-Protection ICs

Layout Recommendations

Proper circuit-board layout is critical to suppress ESD-induced line transients (See Figure 6). The MAX3205E/MAX3207E/MAX3208E clamp to 100V; however, with improper layout, the voltage spike at the device can be much higher. A lead inductance of 10nH with a 45A current spike results in an additional 450V spike on the protected line. It is essential that the layout of the PC board follows these guidelines:

- 1) Minimize trace length between the connector or input terminal, I/O₋, and the protected signal line.
- 2) Use separate planes for power and ground to reduce parasitic inductance and to reduce the impedance to the power rails for shunted ESD current.
- 3) Ensure short low-inductance ESD transient return paths to GND and VCC.
- 4) Minimize conductive power and ground loops.
- 5) Do not place critical signals near the edge of the PC board.
- 6) Bypass VCC to GND with a low-ESR ceramic capacitor as close to VCC as possible.

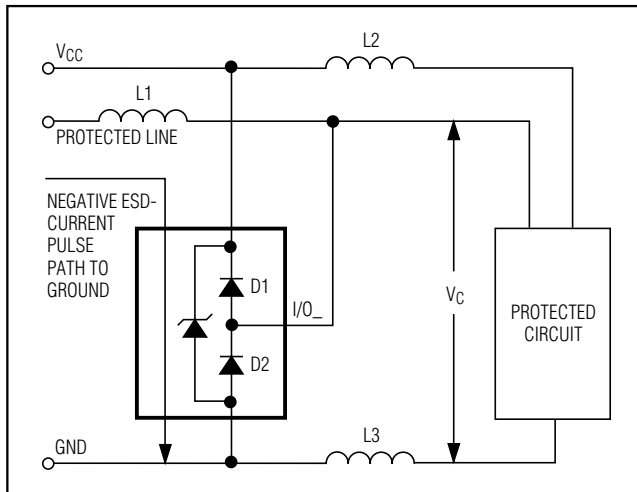

Figure 6. Layout Considerations

- 7) Bypass the supply of the protected device to GND with a low-ESR ceramic capacitor as close to the supply pin as possible.

UCSP Applications Information

For the latest application details on UCSP construction, dimensions, tape carrier information, printed circuit board techniques, bump-pad layout, and recommended reflow temperature profile, as well as the latest information on reliability testing results, go to the Maxim website at www.maxim-ic.com/ucsp for the Application Note, UCSP—A Wafer-Level Chip-Scale Package.

Chip Information

DIODE COUNT:

MAX3205E: 7

MAX3207E: 3

MAX3208E: 5

PROCESS: BiCMOS

Typical Operating Circuit

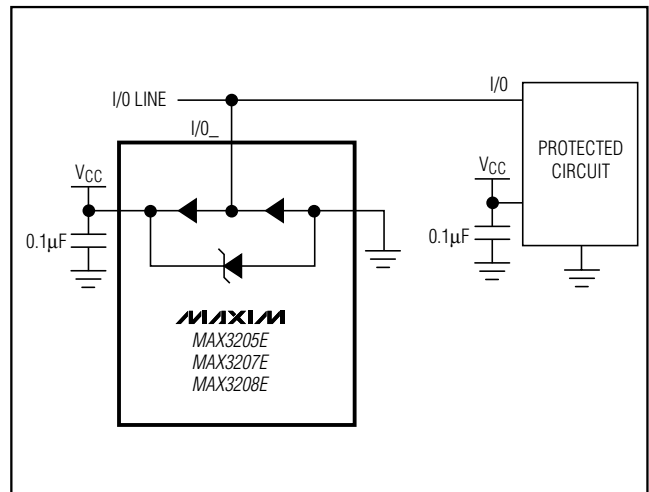

MAX3205E/MAX3207E/MAX3208E

Dual, Quad, and Hex High-Speed Differential ESD-Protection ICs

Package Information

(The package drawing(s) in this data sheet may not reflect the most current specifications. For the latest package outline information, go to www.maxim-ic.com/packages.)

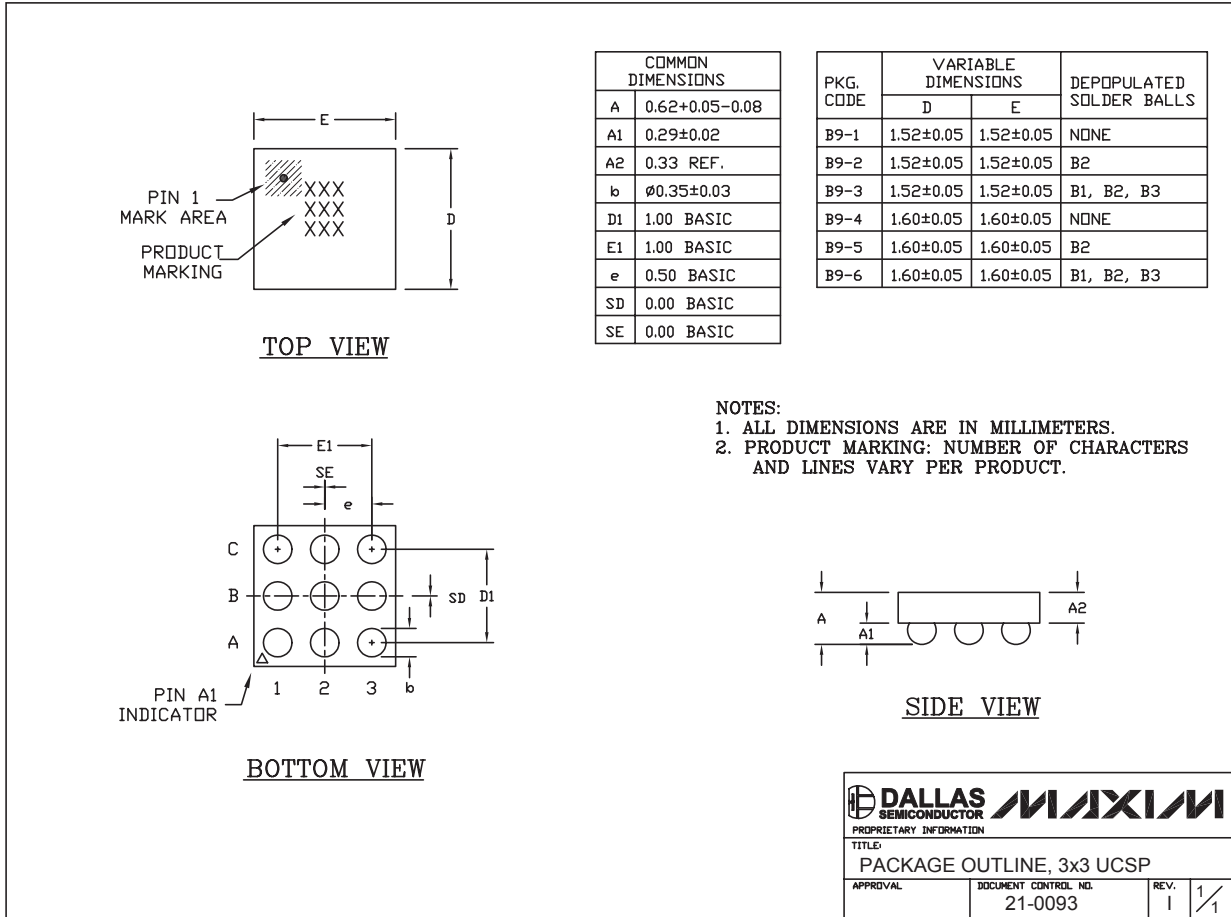

9LUCSP_3x3.EPS

MAX3205E/MAX3207E/MAX3208E

Dual, Quad, and Hex High-Speed Differential ESD-Protection ICs

Package Information (continued)

(The package drawing(s) in this data sheet may not reflect the most current specifications. For the latest package outline information, go to www.maxim-ic.com/packages.)

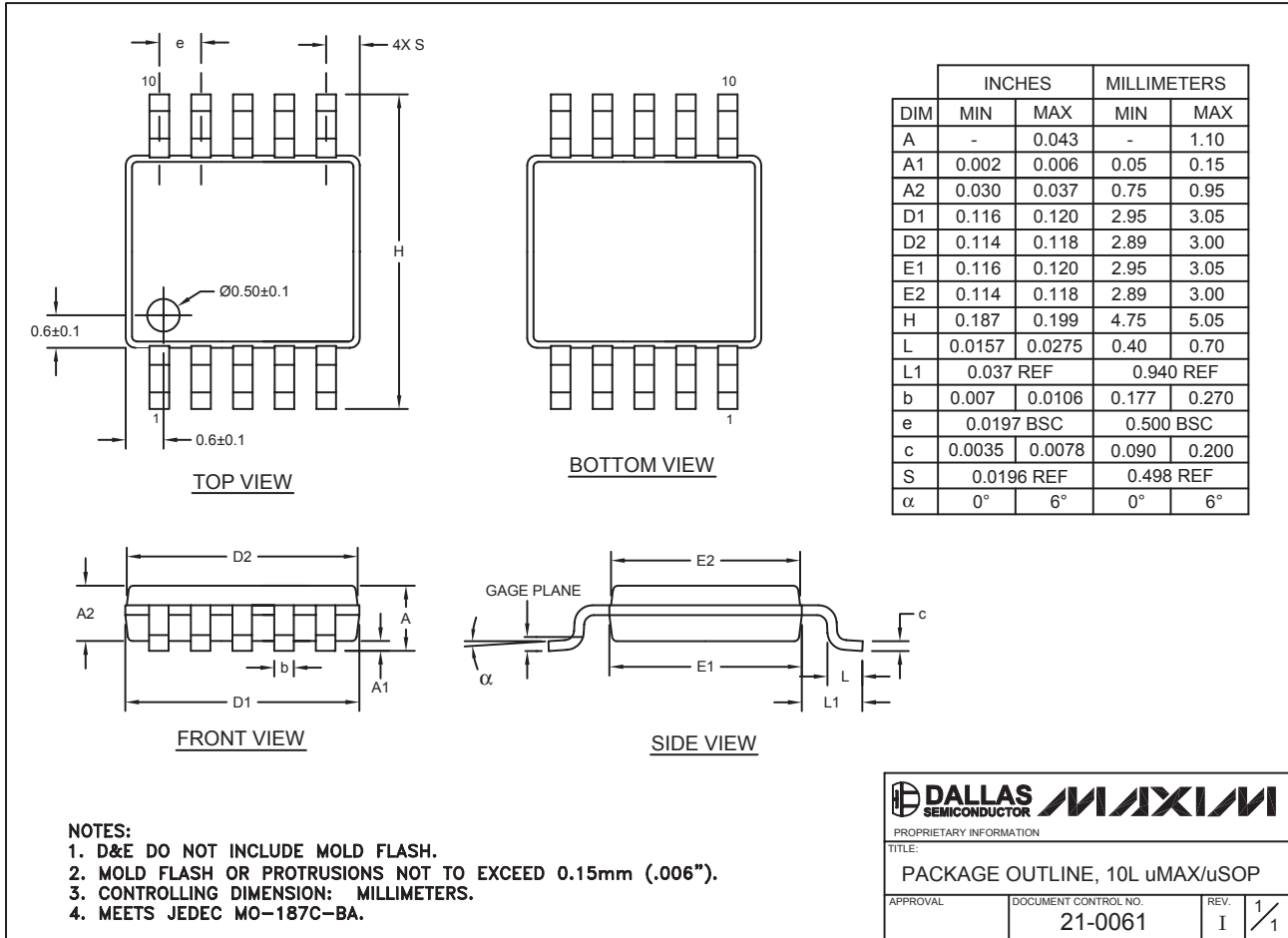

10LUMAX.EPS

Dual, Quad, and Hex High-Speed Differential ESD-Protection ICs

Package Information (continued)

(The package drawing(s) in this data sheet may not reflect the most current specifications. For the latest package outline information, go to www.maxim-ic.com/packages.)

MAX3205E/MAX3207E/MAX3208E

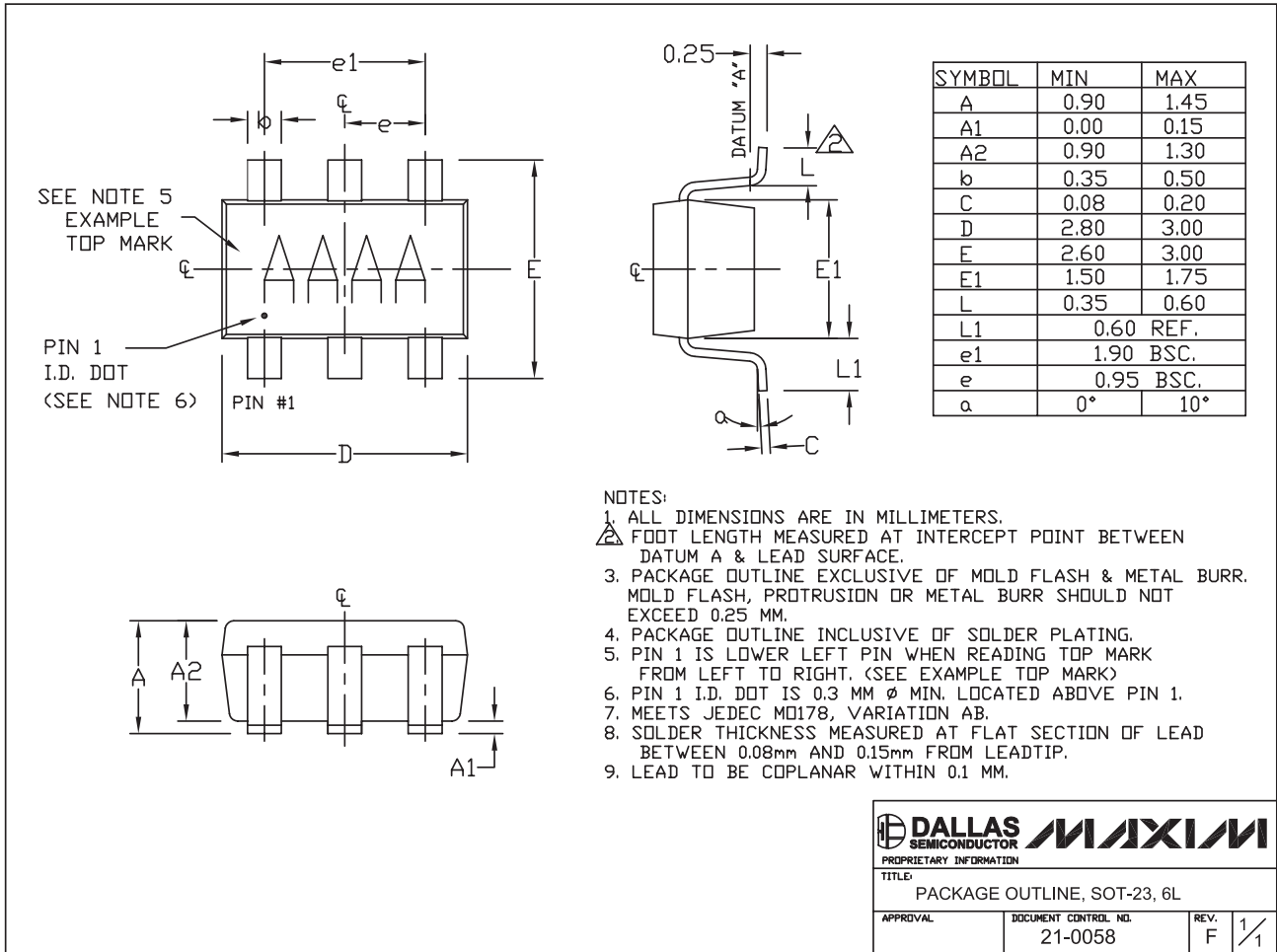

Dual, Quad, and Hex High-Speed Differential ESD-Protection ICs

Package Information (continued)

(The package drawing(s) in this data sheet may not reflect the most current specifications. For the latest package outline information, go to www.maxim-ic.com/packages.)

MAX3205E/MAX3207E/MAX3208E

PKG REF.	12L 3x3			16L 3x3		
	MIN.	NOM.	MAX.	MIN.	NOM.	MAX.
A	0.70	0.75	0.80	0.70	0.75	0.80
b	0.20	0.25	0.30	0.20	0.25	0.30
D	2.90	3.00	3.10	2.90	3.00	3.10
E	2.90	3.00	3.10	2.90	3.00	3.10
e	0.50 BSC.			0.50 BSC.		
L	0.45	0.55	0.65	0.30	0.40	0.50
N	12			16		
ND	3			4		
NE	3			4		
A1	0	0.02	0.05	0	0.02	0.05
A2	0.20 REF			0.20 REF		
k	0.25	-	-	0.25	-	-

PKG CODES	EXPOSED PAD VARIATIONS						PIN ID	JEDEC	DOWN BONDS ALLOWED
	D2			E2					
	MIN.	NOM.	MAX.	MIN.	NOM.	MAX.			
T1233-1	0.95	1.10	1.25	0.95	1.10	1.25	0.35 x 45°	WEED-1	NO
T1233-3	0.95	1.10	1.25	0.95	1.10	1.25	0.35 x 45°	WEED-1	YES
T1633-1	0.95	1.10	1.25	0.95	1.10	1.25	0.35 x 45°	WEED-2	NO
T1633-2	0.95	1.10	1.25	0.95	1.10	1.25	0.35 x 45°	WEED-2	YES
T1633F-3	0.65	0.80	0.95	0.65	0.80	0.95	0.225 x 45°	WEED-2	N/A
T1633-4	0.95	1.10	1.25	0.95	1.10	1.25	0.35 x 45°	WEED-2	NO

NOTES:

- DIMENSIONING & TOLERANCING CONFORM TO ASME Y14.5M-1994.
- ALL DIMENSIONS ARE IN MILLIMETERS. ANGLES ARE IN DEGREES.
- N IS THE TOTAL NUMBER OF TERMINALS.
- ⚠ THE TERMINAL #1 IDENTIFIER AND TERMINAL NUMBERING CONVENTION SHALL CONFORM TO JESD 95-1 SPP-012. DETAILS OF TERMINAL #1 IDENTIFIER ARE OPTIONAL, BUT MUST BE LOCATED WITHIN THE ZONE INDICATED. THE TERMINAL #1 IDENTIFIER MAY BE EITHER A MOLD OR MARKED FEATURE.
- ⚠ DIMENSION b APPLIES TO METALLIZED TERMINAL AND IS MEASURED BETWEEN 0.20 mm AND 0.25 mm FROM TERMINAL TIP.
- ⚠ ND AND NE REFER TO THE NUMBER OF TERMINALS ON EACH D AND E SIDE RESPECTIVELY.
- DEPOPULATION IS POSSIBLE IN A SYMMETRICAL FASHION.
- ⚠ COPLANARITY APPLIES TO THE EXPOSED HEAT SINK SLUG AS WELL AS THE TERMINALS.
- DRAWING CONFORMS TO JEDEC MO220 REVISION C.

	
<small>PROPRIETARY INFORMATION</small>	
TITLE: PACKAGE OUTLINE 12, 16L, THIN QFN, 3x3x0.8mm	
APPROVAL:	DOCUMENT CONTROL NO. 21-0136
REV. E	2/2

Maxim cannot assume responsibility for use of any circuitry other than circuitry entirely embodied in a Maxim product. No circuit patent licenses are implied. Maxim reserves the right to change the circuitry and specifications without notice at any time.

Maxim Integrated Products, 120 San Gabriel Drive, Sunnyvale, CA 94086 408-737-7600 _____ 13