



MAX3264/MAX3265 Evaluation Kits

General Description

The MAX3264 evaluation kit (EV kit) (data rate up to 1.25Gbps) evaluates the MAX3264/MAX3268 limiting amplifiers. The MAX3265 EV kit (data rate up to 2.5Gbps) evaluates the MAX3265/MAX3269 limiting amplifiers.

These EV kits allow easy programming of the loss-of-signal (LOS) threshold and provide layout options for alternate termination configurations. The circuit includes space for a user-supplied preamplifier and photodiode pair mounted in a TO-46 can. Both EV kits have evaluation sites for a 16-pin TSSOP with electrical input, a 10-pin μ MAX with electrical input, and a 10-pin μ MAX with optical input (not installed). See Figure 1 for an overview of possible configurations.

Component Suppliers

SUPPLIER	PHONE	FAX
AVX	803-649-0690	803-626-3123
Murata	814-237-1431	814-238-0490
Sprague	516-435-1110	516-435-1824
Zetex USA	516-543-7100	516-864-7630

Note: Please indicate that you are using the MAX3264 or MAX3265 EV kit when contacting these component suppliers.

Features

- ◆ Easy LOS Threshold Programming
- ◆ Allow Alternate Output Terminations
- ◆ Circuit Includes Space for TO-46 PIN-TIA Optical Input
- ◆ 1.25Gbps Data Rate (MAX3264EVKIT)
2.5Gbps Data Rate (MAX3265EVKIT)

Ordering Information

PART	TEMP. RANGE	IC PACKAGE
MAX3264EVKIT-SO	0°C to +70°C	16 TSSOP* (MAX3264), 10 μ MAX* (MAX3268)
MAX3265EVKIT-SO	0°C to +70°C	16 TSSOP* (MAX3265), 10 μ MAX* (MAX3269)

*Exposed pad packages

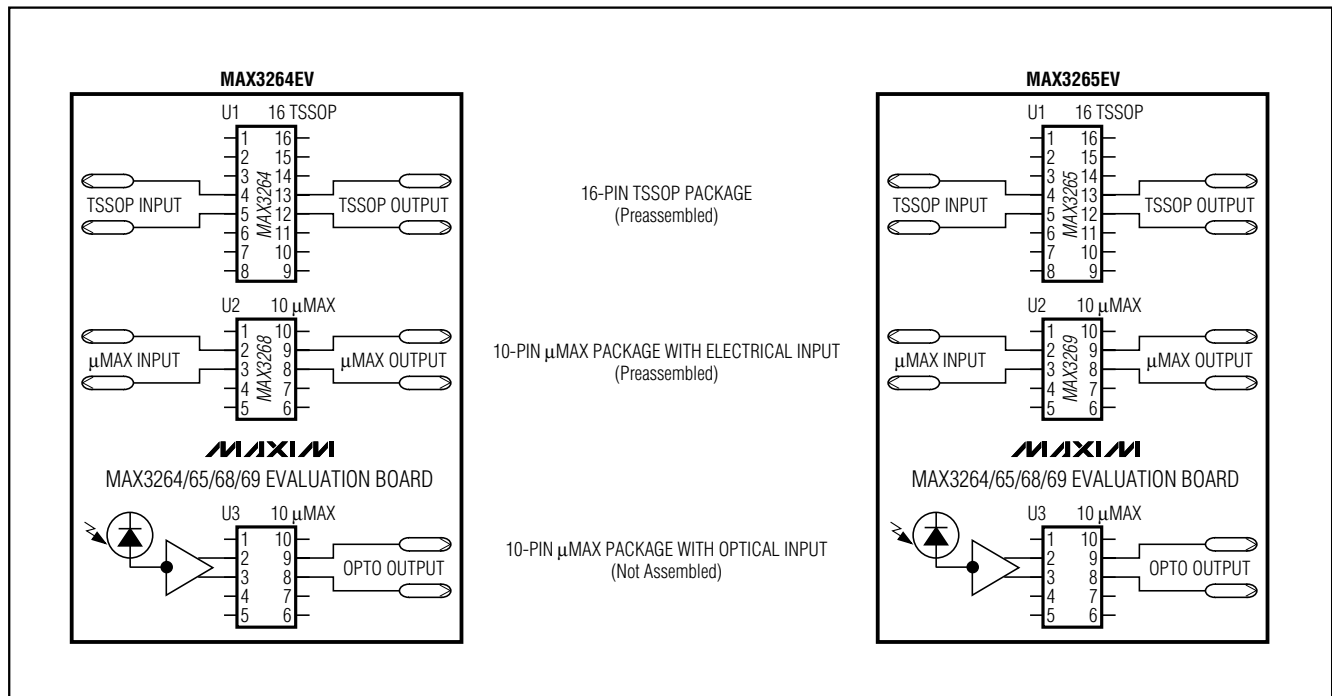

Figure 1. Overview of Layout Topographies

Evaluate: MAX3264/MAX3265/MAX3268/MAX3269



MAX3264/MAX3265 Evaluation Kits

Component List

DESIGNATION	QTY	DESCRIPTION
C1, C4, C6, C9–C11, C14–C17, C19, C30–C32	14	1000pF \pm 10%, 10V ceramic capacitors (0603)
C2, C3, C7, C8, C12, C13	6	0.01 μ F \pm 10%, 10V ceramic capacitors (0603)
C5, C26, C27	3	0.1 μ F \pm 10%, 10V ceramic capacitors
C18, C20, C21, C28, C29, C33, C34	7	Not installed
C22, C23	2	33 μ F \pm 10%, 16V tantalum caps AVX TAJC336K016
C24, C25	2	2.2 μ F \pm 10%, 10V ceramic capacitors (1206)
R1, R2	2	100 Ω \pm 1% resistors (0603)
R3, R12	2	50k Ω variable resistors
R4, R13	2	5k Ω variable resistors
R5, R8, R9, R15, R16, R17	6	Not installed
R7, R14	2	330 Ω \pm 5% resistors (0603)
R10, R11	2	0 Ω resistors (0603)

DESIGNATION	QTY	DESCRIPTION
L1, L2	2	Ferrite beads Murata BLM21A102S (0603)
L3	1	Not installed
J2–J5, J7, J8, J10, J11	8	SMA connectors (edge mount)
J6, J18–J20	4	2-pin headers (0.1in centers)
J13, J14		Not placed
J22	1	3-pin header (0.1in centers)
D1, D2	2	Red LEDs
D3	1	Not installed
U1	1	MAX3264CUE (MAX3264EVKIT) MAX3265CUE (MAX3265EVKIT)
U2	1	MAX3268CUB (MAX3264EVKIT) MAX3269CUB (MAX3265EVKIT)
U3		Not installed
None	3	Shunts for J6, J22, and J18 or J19 or J20
None	1	MAX3264 or MAX3265 EV kit circuit board, Rev. B
None	1	MAX3264/MAX3265/MAX3268/MAX3269 data sheet

Quick Start

MAX3264/MAX3265 TSSOP Package

- 1) Install a shunt on J18 to apply power (J19, J20 open).
- 2) Install a shunt on terminals 1 and 2 of J22 to disable squelch.
- 3) Connect OUT+ and OUT- to a 50 Ω terminated oscilloscope.
- 4) Apply an input (10mVp-p to 1.2Vp-p) to J4 and J5.
- 5) Connect a +3.0V to +5.5V power supply to the VCC pad, then connect the power-supply ground to the GND pad.
- 6) Adjust the LOS threshold with R3 and R4.

MAX3268/MAX3269 μ MAX Package with Electrical Input

- 1) Install a shunt on J19 to apply power (J18, J20 open).
- 2) Apply an input (10mVp-p to 1.2Vp-p) to J7 and J8.

- 3) Connect OUT+ and OUT- to a 50 Ω terminated oscilloscope.
- 4) Apply 2V to VCC, ground to GND, and a -1.0V to -3.5V power supply to VEE.
- 5) Adjust the LOS threshold with R12 and R13.

Detailed Description

LOS Voltage Threshold Adjustment

Potentiometers R3, R4, R12, and R13 adjust the V_{TH} voltage, which programs the LOS threshold. Refer to the MAX3264/MAX3265/MAX3268/MAX3269 data sheet for details.

CML Output Buffer

The MAX3264/MAX3265 CML output circuits provide high tolerance to impedance mismatches and inductive connectors. The output current can be set for either of two levels. When the LEVEL pin is left unconnected (J6 open), the output current is approximately 16mA. Connecting the LEVEL pin to ground (J6 closed) sets the output current to approximately 20mA.

MAX3264/MAX3265 Evaluation Kits

Evaluate: MAX3264/MAX3265/MAX3268/MAX3269

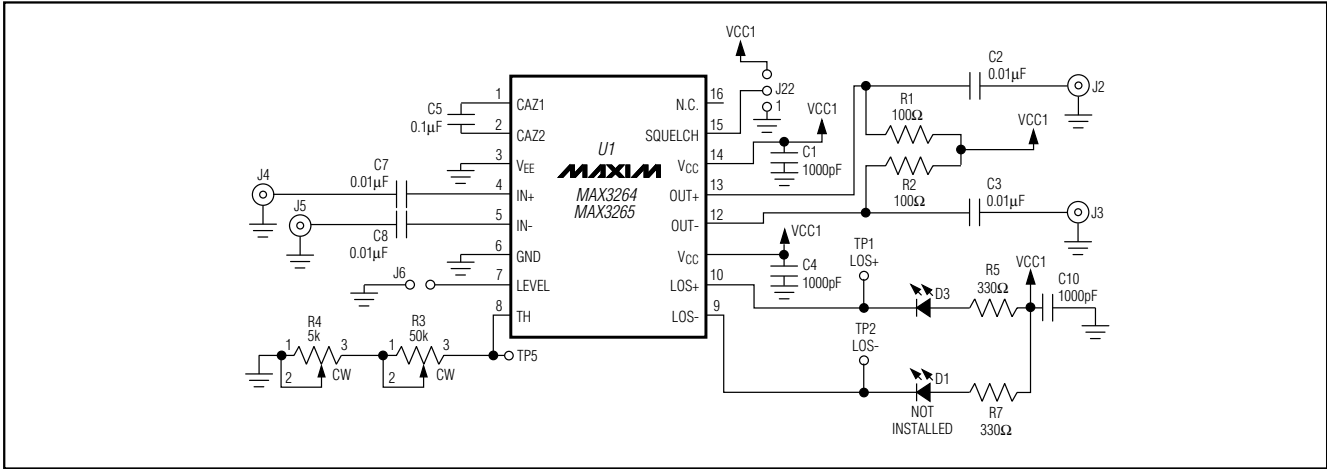

Figure 2. MAX3264/MAX3265 EV Kits Schematic (TSSOP Package)

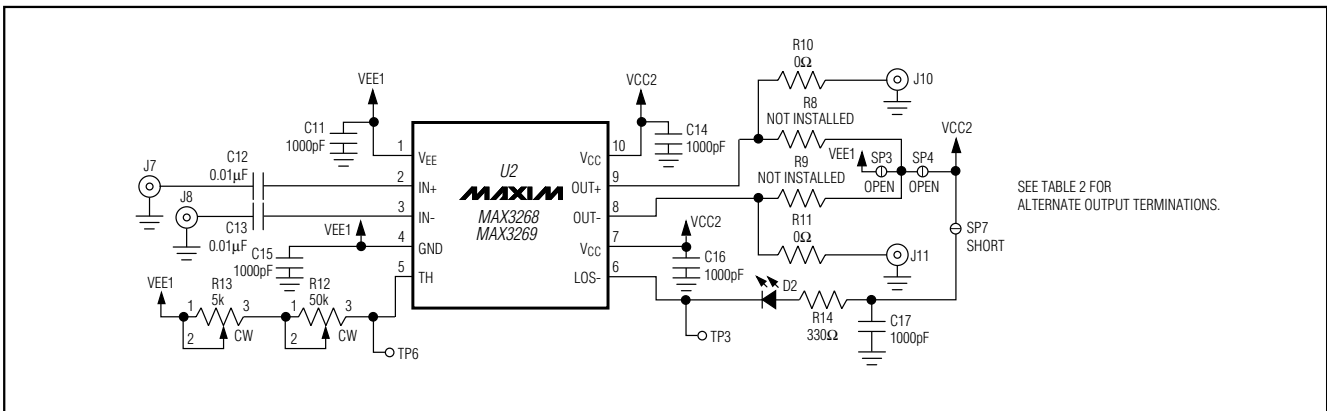

Figure 3. MAX3264/MAX3265 EV Kits Schematic (µMAX Package with Electrical Input)

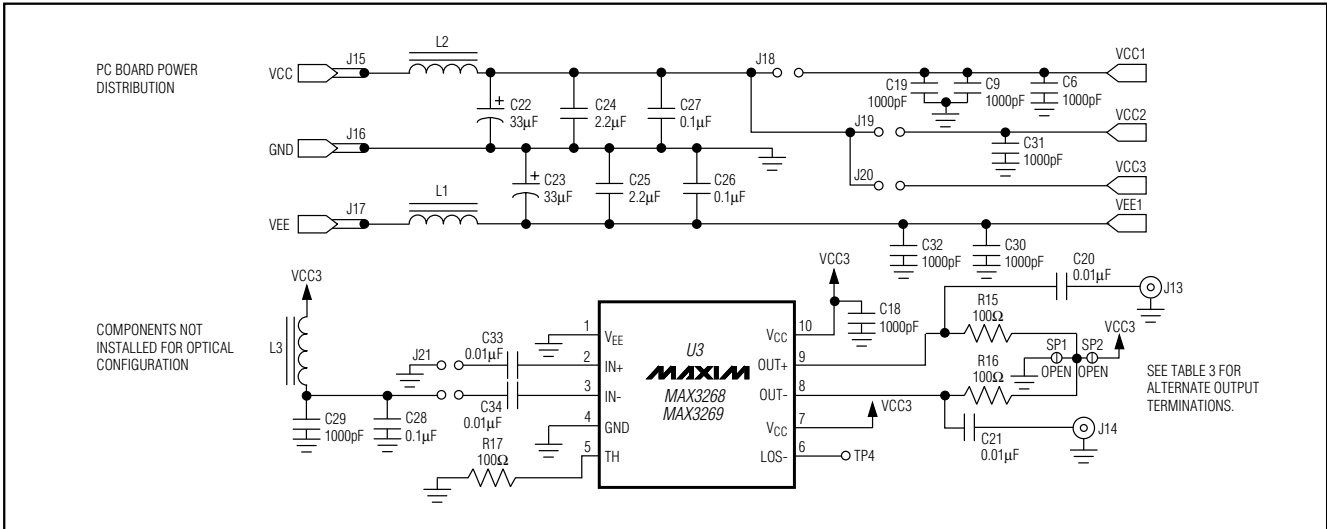

Figure 4. MAX3264/MAX3265 EV Kits Schematic (µMAX Package with Optical Input)

MAX3264/MAX3265 Evaluation Kits

Table 1. Jumpers and Potentiometers

NAME	FUNCTION
J18	Applies power to U1
J19	Applies power to U2
J20	Applies power to U3
J22 (Pins 1–2)	Disables squelch
J22 (Pins 2–3)	Enables squelch
R3, R4	Adjusts LOS threshold of U1 (0Ω is clockwise)
R12, R13	Adjusts LOS threshold of U2 (0Ω is clockwise)

NAME	FUNCTION
SP1	Solder jumper for alternate terminations (Table 3)
SP2	Solder jumper for alternate terminations (Table 3)
SP3	Solder jumper for alternate terminations (Table 2)
SP4	Solder jumper for alternate terminations (Table 2)
SP7	Normally shorted

Table 2. Output Terminations for Electrical Input (U2)

OUTPUT LOGIC	OUTPUT TERMINATIONS	CONDITIONS
PECL MAX3268CUB/ MAX3269CUB	<p>CONFIGURATION 1 (Default)</p>	<p>SP3 open, SP4 open, R8 = R9 = do not install, R10 = R11 = 0Ω, VCC = 2V, VEE = -1.0V to -3.5V, GND = 0V, oscilloscope is referenced to ground</p>
	<p>CONFIGURATION 2</p>	<p>SP3 closed, SP4 open, R8 = R9 = 330Ω, R10 = R11 = 0.1μF, VCC = 3V to 5.5V, VEE = GND = 0V</p>
	<p>CONFIGURATION 3</p>	<p>SP3 open, SP4 open, R8 = R9 = do not install, R10 = R11 = 0Ω, VCC = 3V to 5.5V, VEE = GND = 0V, oscilloscope must be referenced to VCC - 2V</p>

MAX3264/MAX3265 Evaluation Kits

Evaluate: MAX3264/MAX3265/MAX3268/MAX3269

Table 2. Output Terminations for Electrical Input (U2) (continued)

OUTPUT LOGIC	OUTPUT TERMINATIONS	CONDITIONS
CML MAX3265CUB	<p>CONFIGURATION 4</p>	<p>SP3 open, SP4 closed, R8 = R9 = 100Ω, R10 = R11 = 0.1μF, VCC = 3V to 5.5V, VEE = GND = 0V</p>

Table 3. Output Terminations for Optical Input (U3)

OUTPUT LOGIC	OUTPUT TERMINATIONS	CONDITIONS
PECL MAX3268CUB/ MAX3269CUB	<p>CONFIGURATION 1</p>	<p>SP1 closed, SP2 open, R15 = R16 = 330Ω, C20 = C21 = 0.1μF, VCC = 3V to 5.5V, VEE = GND = 0V</p>
	<p>CONFIGURATION 2</p>	<p>SP1 open, SP2 open, R15 = R16 = do not install, C20 = C21 = 0Ω, VCC = 3V to 5.5V, VEE = GND = 0V, oscilloscope must be referenced to VCC - 2V</p>
CML MAX3265CUB	<p>CONFIGURATION 3</p>	<p>SP1 open, SP2 closed, R15 = R16 = 100Ω, C20 = C21 = 0.1μF, VCC = 3V to 5.5V, VEE = GND = 0V</p>

MAX3264/MAX3265 Evaluation Kits

Evaluate: MAX3264/MAX3265/MAX3268/MAX3269

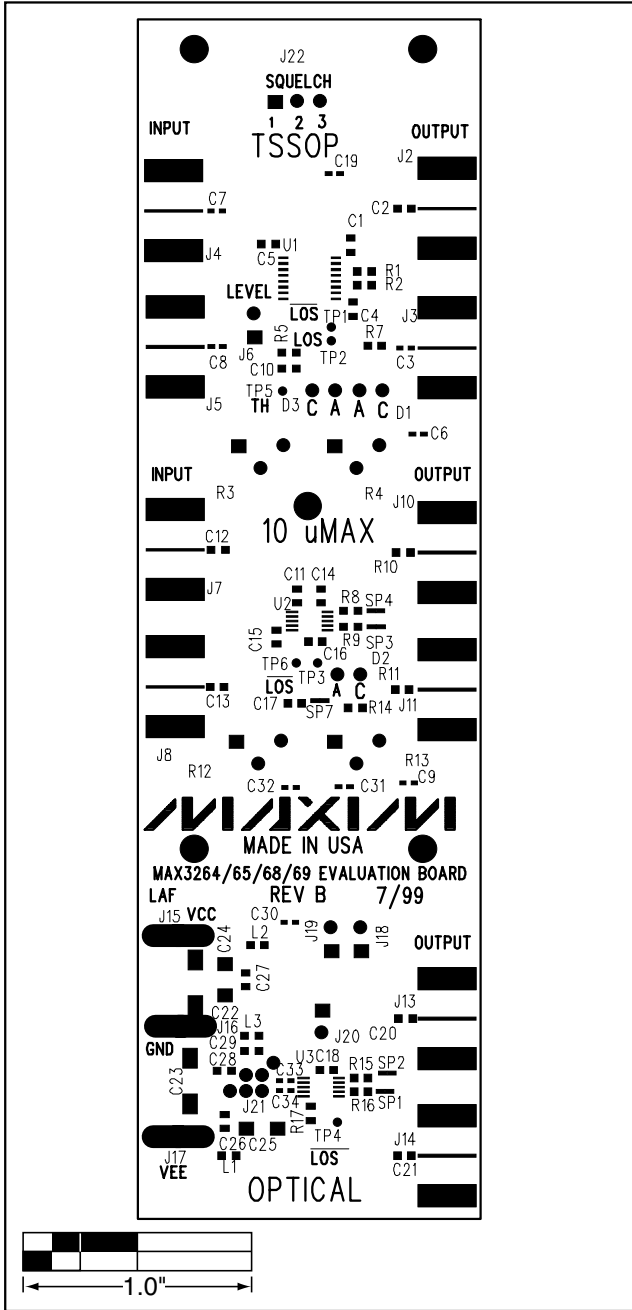

Figure 5. MAX3264/MAX3265 EV Kits Component Placement Guide

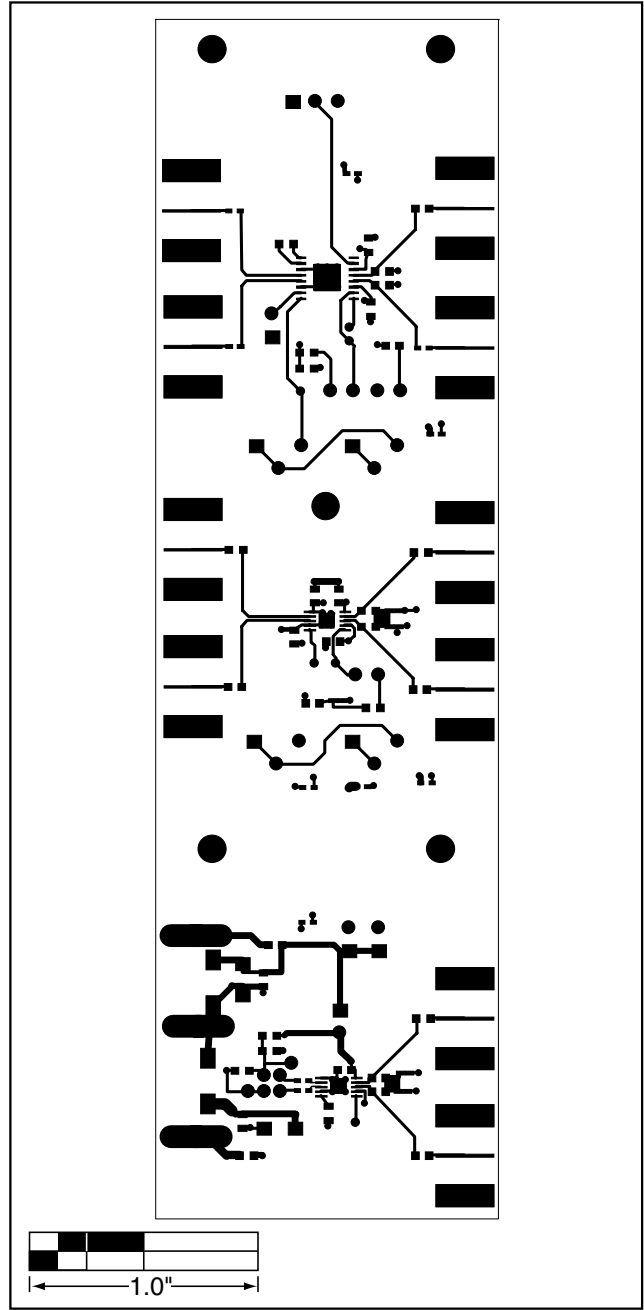

Figure 6. MAX3264/MAX3265 EV Kits PC Board Layout—Component Side

MAX3264/MAX3265 Evaluation Kits

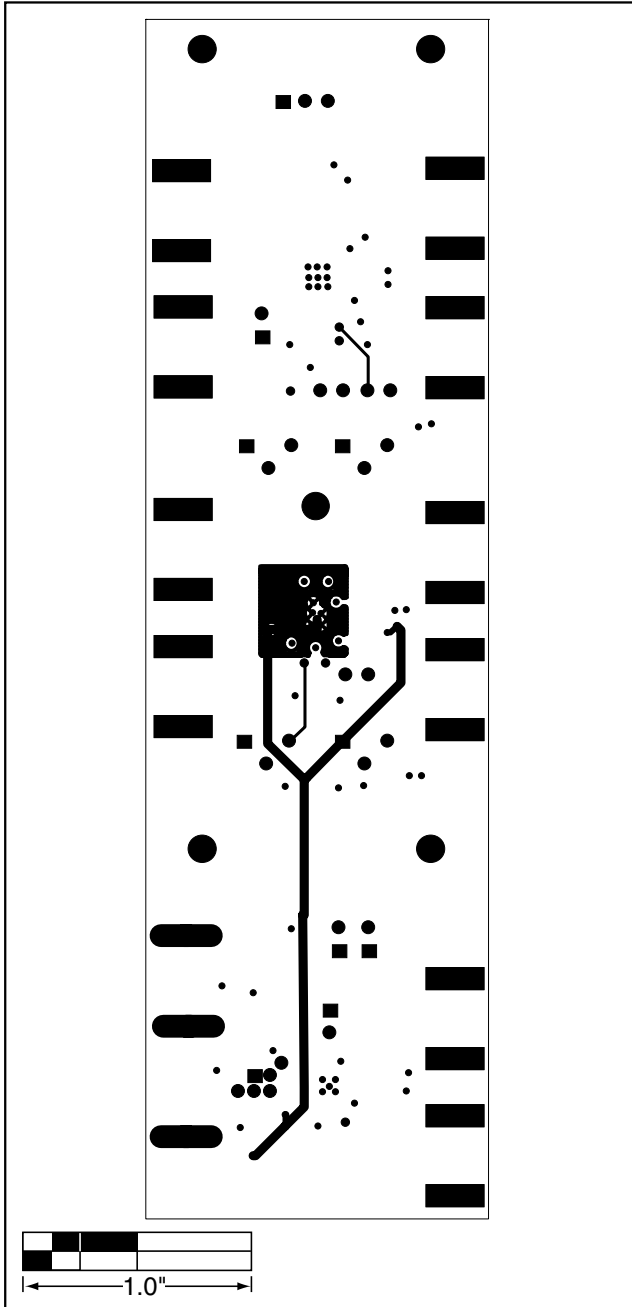

Figure 7. MAX3264/MAX3265 EV Kits PC Board Layout—Solder Side

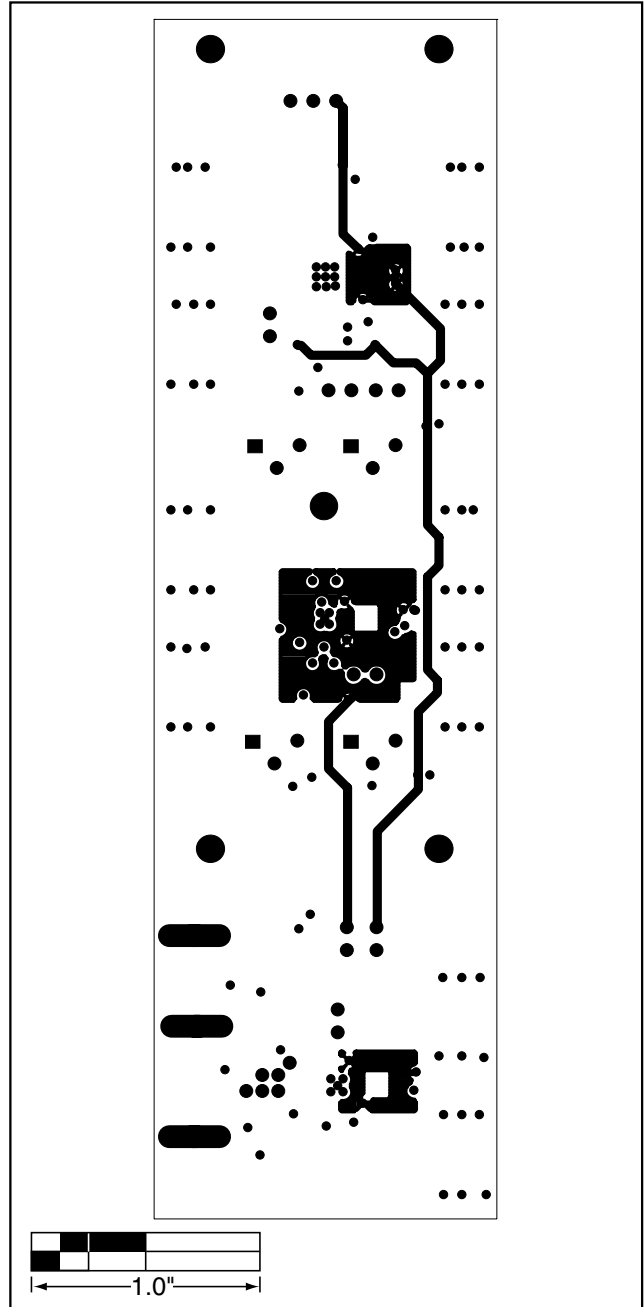

Figure 8. MAX3264/MAX3265 EV Kits PC Board Layout—Power Plane

Evaluate: MAX3264/MAX3265/MAX3268/MAX3269

MAX3264/MAX3265 Evaluation Kits

Evaluate: MAX3264/MAX3265/MAX3268/MAX3269

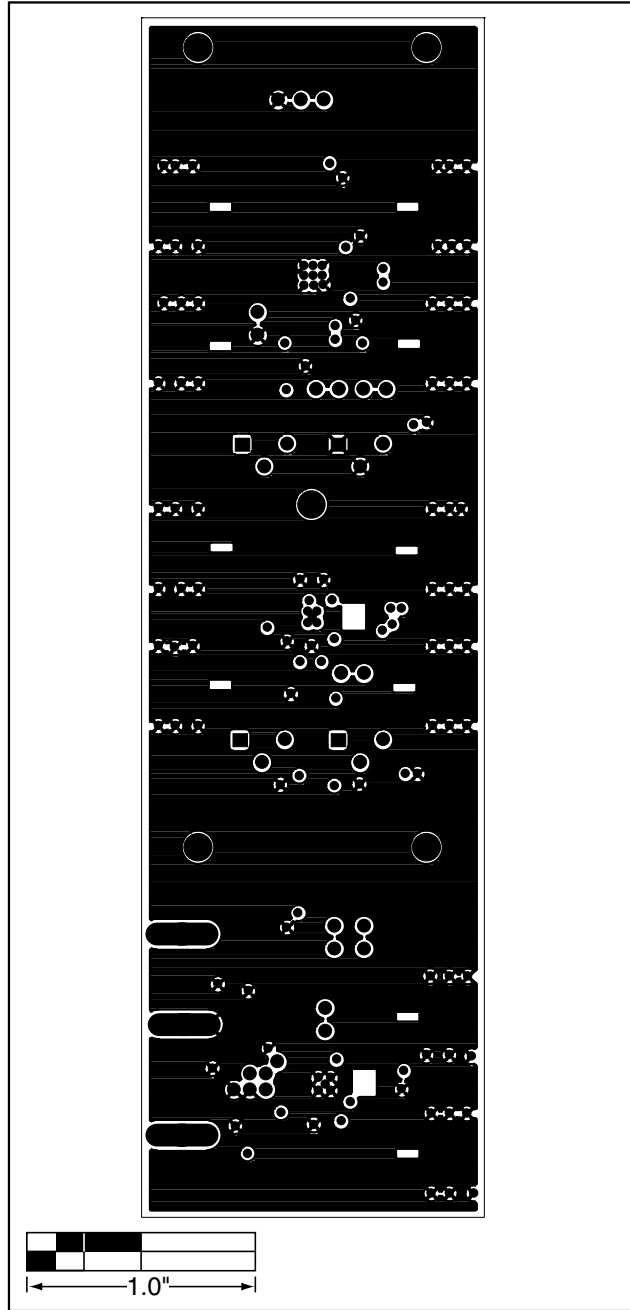

Figure 9. MAX3264/MAX3265 EV Kits PC Board Layout—GND Plane

Maxim cannot assume responsibility for use of any circuitry other than circuitry entirely embodied in a Maxim product. No circuit patent licenses are implied. Maxim reserves the right to change the circuitry and specifications without notice at any time.

8 **Maxim Integrated Products, 120 San Gabriel Drive, Sunnyvale, CA 94086 408-737-7600**