

# MAXIM

## MAX3272A Evaluation Kit

### General Description

The MAX3272A evaluation kit (EV Kit) is fully assembled and tested to provide easy evaluation of the MAX3272A +3.3V, 2.5Gbps low power limiting amplifier. The EV Kit also includes a calibration strip for accurate measurements.

### Component List

DESIGNATION	QTY	DESCRIPTION
C1	1	33 $\mu$ F $\pm$ 10% tantalum capacitor
C2	1	2.2 $\mu$ F $\pm$ 10% tantalum capacitor
C3, C16	2	0.1 $\mu$ F $\pm$ 10% ceramic capacitors (0402)
C4 - C7	4	1000pF $\pm$ 10% ceramic capacitors (0402)
C8 - C15, C17	9	0.01 $\mu$ F $\pm$ 10% ceramic capacitors (0402)
R1, R2	2	4.75k $\Omega$ resistors $\pm$ 1% (0402)
R3	1	20k $\Omega$ potentiometer
R4	1	2k $\Omega$ potentiometer
L1	1	56nH inductor Coilcraft 0805CS-560XKBC
U1	1	MAX3272AEGP 20-QFN*
J1 - J8	8	SMA connectors edge mount (round contact)
J9, J10, J11	3	1X3 pin headers (0.1" centers)
J12, J13	2	1X2 pin headers (0.1" centers)
J14, J15, TP1, TP2	4	Test points
None	1	MAX3272A evaluation circuit board, rev A
None	1	MAX3272 / MAX3272A data sheet

\*Note: U1 has an exposed pad which requires it to be solder attached to the circuit board to insure proper functionality of the part.

### Features

- ◆ Single +3.3V Power Supply
- ◆ Fully Assembled and Tested
- ◆ Includes Calibration Strip for Accurate Measurements
- ◆ EV Kit Designed for 50 $\Omega$  Interfaces
- ◆ Easy LOS Threshold Programming
- ◆ Easy Output Polarity Control

### Ordering Information

PART	TEMP RANGE	IC PACKAGE
MAX3272AEVKIT	-40°C to +85°C	20 QFN

### Component Suppliers

SUPPLIER	PHONE	FAX
AVX	843-448-9411	843-448-1943
Coilcraft	847-639-6400	847-639-1469
Murata	814-237-1431	814-238-0490
Venkel	800-950-8365	512-794-0087

Note: Please indicate that you are using the MAX3272A when ordering from these suppliers.

### Quick Start

- 1) Connect a shunt across pins 1 (VCC) and 2 of jumper J9 for no inversion in the output polarity.
- 2) Ensure that J13 is open.
- 3) Connect OUT+ and OUT- to a 50 $\Omega$  terminated oscilloscope.
- 4) Apply a differential input (15mV<sub>P-P</sub> to 1200mV<sub>P-P</sub>) between IN+ and IN-.
- 5) Connect a +3.3V power supply to J14 (VCC), then connect the power supply ground to J15 (GND).
- 6) Adjust the LOS threshold with R3 and R4.
- 7) The output amplitude is approximately 750mV<sub>P-P</sub>.

Evaluates: MAX3272A

# MAX3272A Evaluation Kit

## Detailed Description

### LOS Threshold Adjustment

Potentiometers R3 and R4 program the LOS assert threshold. Refer to the MAX3272 / MAX3272A Data Sheet for details on setting the threshold.

### Setting the Offset Correction Capacitor

Jumper J10 sets the offset correction loop capacitor. Short pins 1 and 2 to set CAZ=0.1 $\mu$ F; short pins 2 and 3 to disable the offset correction loop. Leave J10 unconnected for a higher cutoff frequency. Refer to the MAX3272 / MAX3272A Data Sheet for details.

### Setting the Output Polarity

Jumper J9 sets the output polarity. Short pins 1 (VCC) and 2 for no signal inversion, and short pins 2 and 3 (GND) for an inversion in output polarity.

### Setting the Squelch Function

Jumper J11 controls the squelch function. To enable squelch, short pins 1 (VCC) and 2. To disable, short pins 2 and 3 (GND) or leave unconnected.

### Setting the Output Current

Jumper J13 sets the output current level. For 16mA CML output current, leave this jumper open. For approximately 20mA, short the jumper.

### Setting the LOS Capacitor

Jumper J12 sets the LOS Time Constant Capacitor. To connect a 0.01 $\mu$ F capacitor, short the jumper. For a shorter time constant (about 2 $\mu$ s), leave the jumper open.

### LOS Test Point

Test Point 1 is used to probe the LOS voltage. This pin should indicate high ( $\geq 2.4V$ ) when loss of signal is detected, and indicate low ( $\leq 0.4V$ ) in normal operation.

### LOS Test Point

Test Point 2 is used to probe the  $\overline{\text{LOS}}$  voltage. This pin should indicate low ( $\leq 0.4V$ ) when loss of signal is detected, and indicate high ( $\geq 2.4V$ ) in normal operation.

# MAX3272A Evaluation Kit

Evaluates: MAX3272A

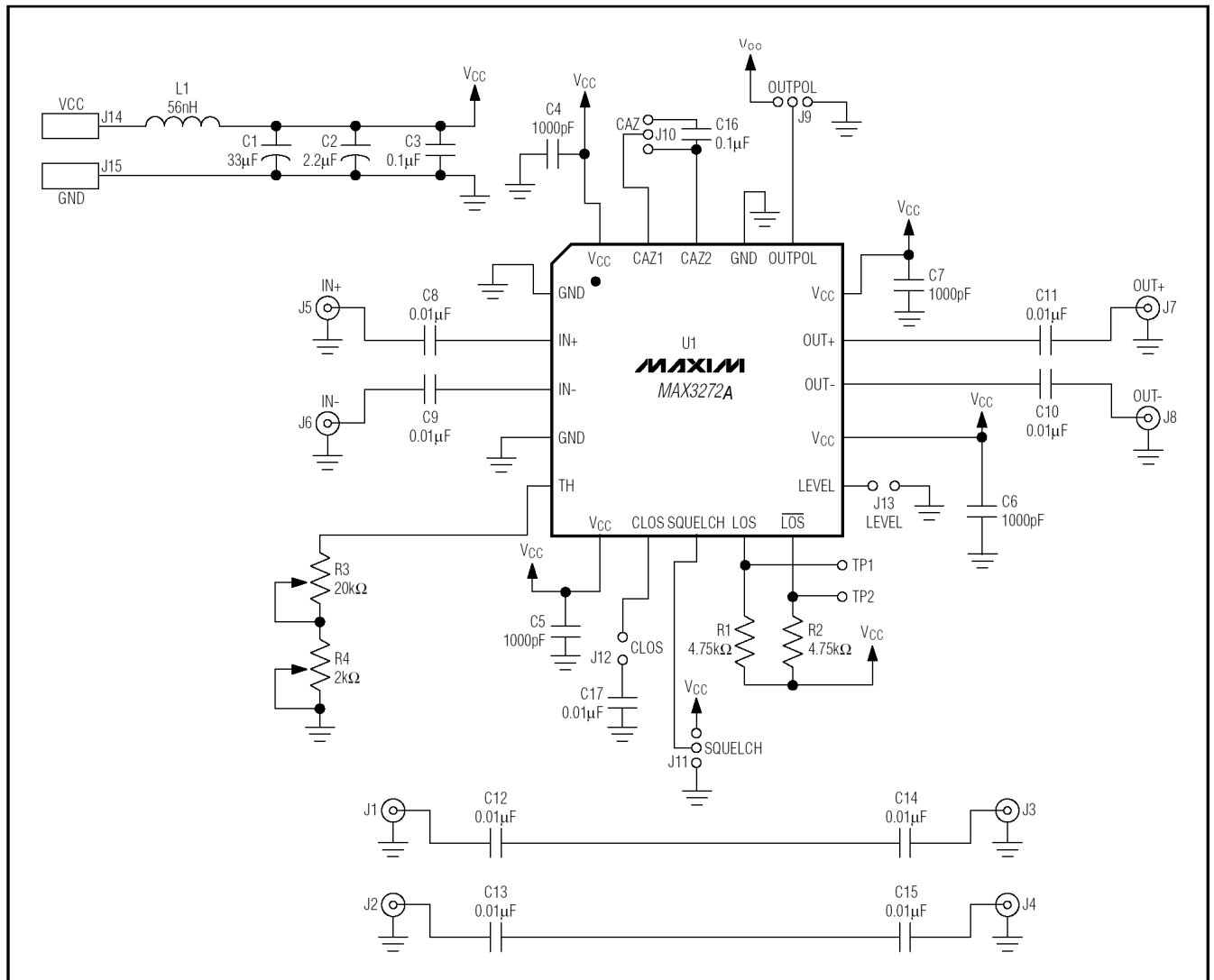

Figure 1. MAX3272A EV Kit Schematic

# MAX3272A Evaluation Kit

Evaluates: MAX3272A

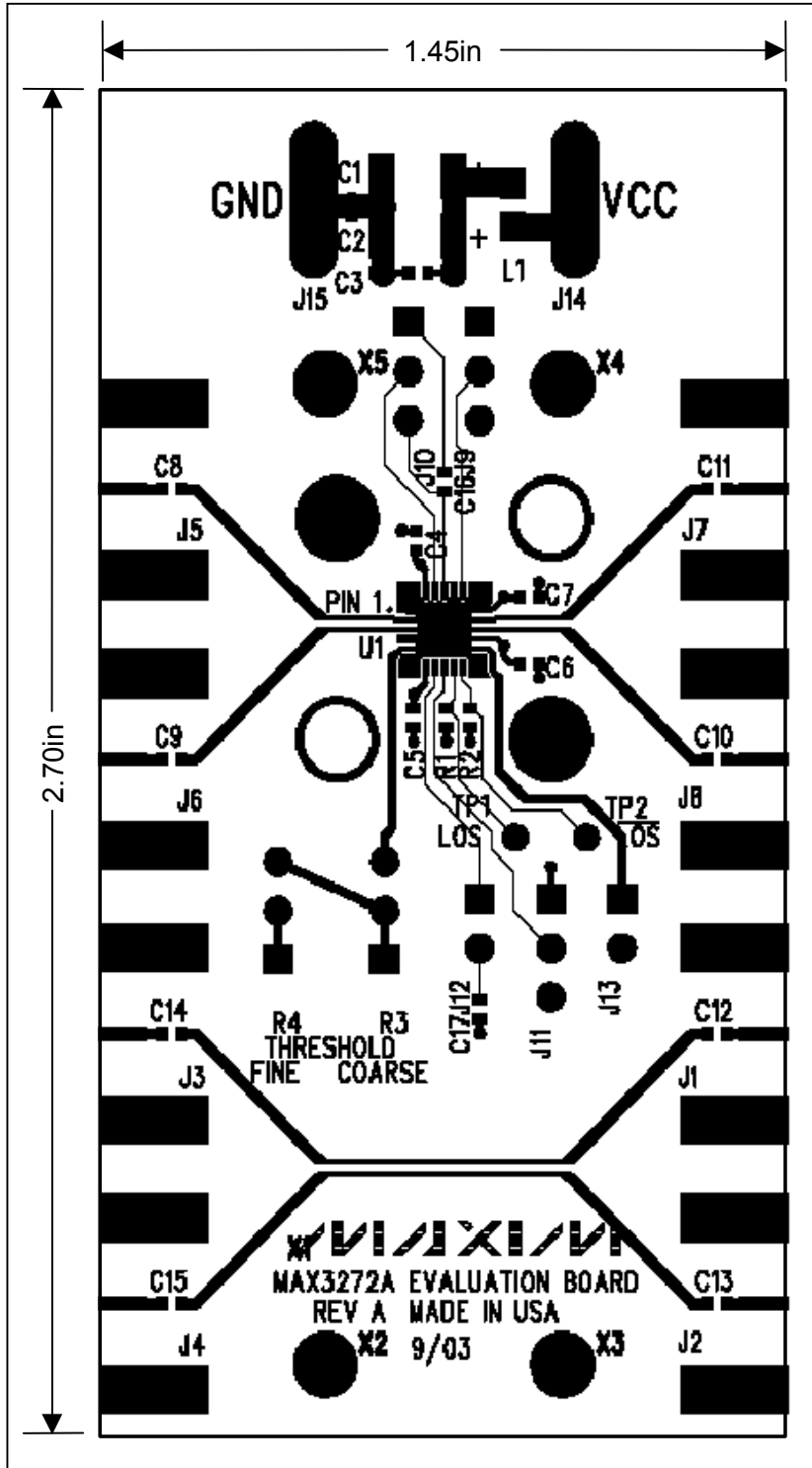

Figure 2. MAX3272A EV Kit Component Placement Guide – Component Side

# MAX3272A Evaluation Kit

Evaluates: MAX3272A

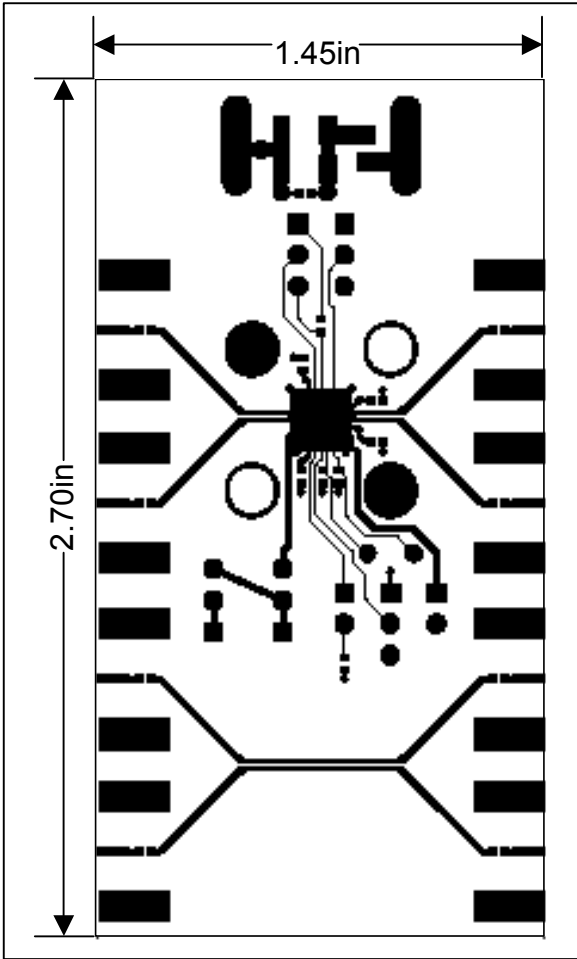

Figure 3. MAX3272A EV Kit PC Board Layout – Component Side

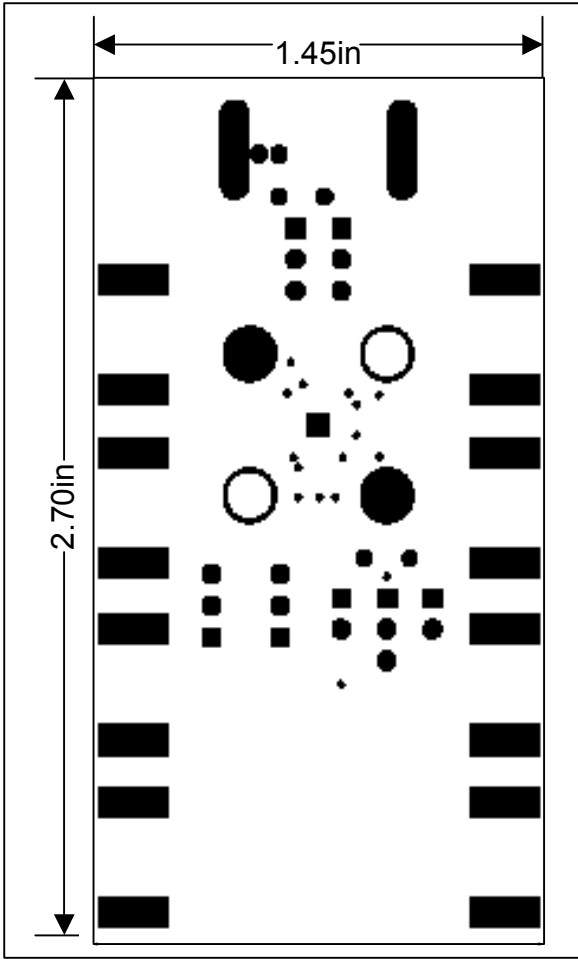

Figure 4. MAX3272A EV Kit PC Board Layout – Solder Side

# MAX3272A Evaluation Kit

**Evaluates: MAX3272A**

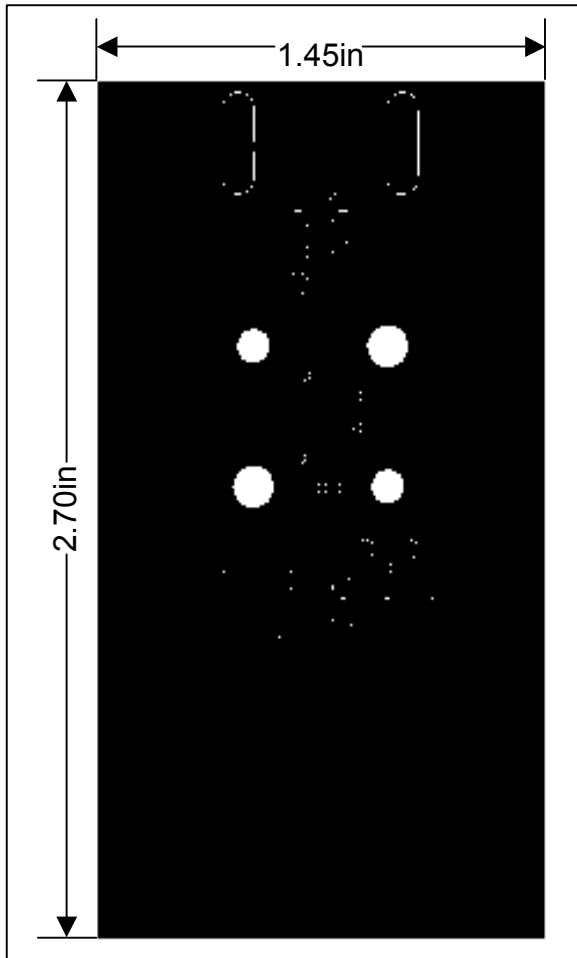

Figure 5. MAX3272A EV Kit PC Board Layout – Ground Plane

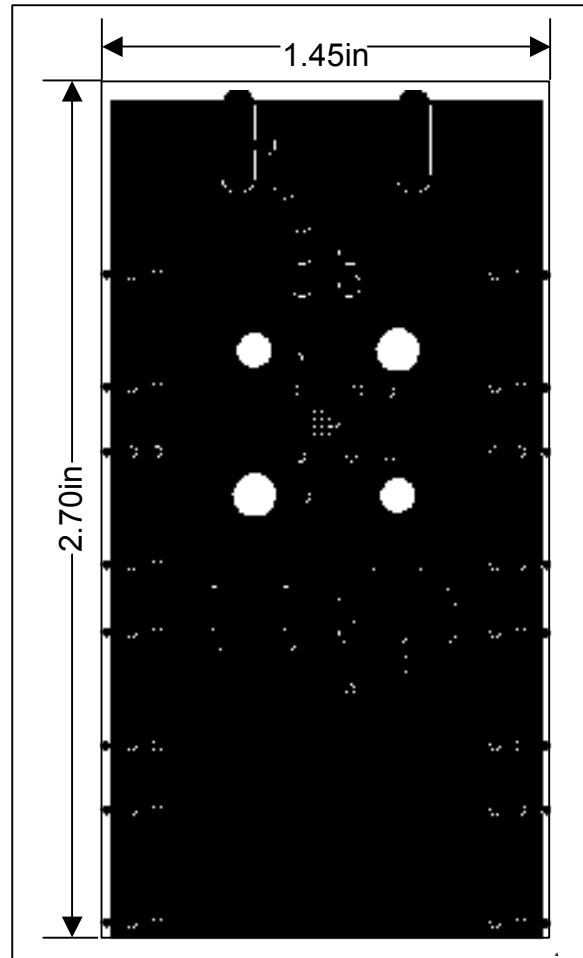

Figure 6. MAX3272A EV Kit PC Board Layout – Power Plane

*Maxim makes no warranty, representation or guarantee regarding the suitability of its products for any particular purpose, nor does Maxim assume any liability arising out of the application or use of any product or circuit and specifically disclaims any and all liability, including without limitation consequential or incidental damages. "Typical" parameters can and do vary in different applications. All operation parameters, including "typicals" must be validated for each customer application by customer's technical experts. Maxim products are not designed, intended or authorized for use as components in systems intended for surgical implant into the body, or other applications intended to support or sustain life, or for any other application in which the failure of the Maxim product could create a situation where personal injury or death may occur.*