

MAXIM

MAX3645 Evaluation Kit

Evaluates: MAX3645

General Description

The MAX3645 evaluation kit (EV kit) simplifies evaluation of the MAX3645 limiting amplifier. The EV kit allows easy programming of the loss-of-signal (LOS) threshold and provides layout options for alternate output terminations.

Component List

DESIGNATION	QTY	DESCRIPTION
C1, C2	2	33 μ F \pm 10% tantalum capacitors AVX TAJB336K010R
C3, C4	2	3.3 μ F \pm 10% ceramic capacitors (0805)
C5–C9, C12, C13	7	0.1 μ F \pm 10% ceramic capacitors Murata GRP155R61A104K
C11	1	1000pF \pm 10% ceramic capacitor Murata GRP155R71H102K
J1, J2, J5, J6	4	SMA connectors (edge mount) EF Johnson 142-0701-801
J3, J4, J9	3	Test points Digi-Key 5000K-ND
JU1	1	2 \times 5-pin header block, 0.1in centers Digi-Key S1012-36-ND
JU2–JU4	3	2-pin headers, 0.1in centers
JU1–JU4	4	Shunts Digi-Key S9000-ND
L1, L2	2	1.2 μ H inductors Coilcraft 1008CS-122XJBC
R1, R2	2	84.5 Ω \pm 1% resistors (0402)
R3	1	5k Ω variable resistor Digi-Key 3296W-1-502-ND
R4	1	100 Ω \pm 1% resistor (0402)
R5	1	1k Ω \pm 1% resistor (0402)
R6	1	2k Ω \pm 1% resistor (0402)
R8, R9	2	49.9 Ω \pm 1% resistors (0402)
R13, R15	2	49.9 Ω \pm 1% resistors (0805)
R19, R21	2	Not installed
SB1	1	Solder bridge, open
TP1–TP3, TP9–TP11	6	Test points Digi-Key 5000K-ND
U1	1	MAX3645ESE 16-pin SOIC (MAX3645ESEEVKIT)
		MAX3645EEEE 16-pin QSOP (MAX3645EEEEVKIT)
None	1	MAX3645ESE EV kit circuit board, Rev A (MAX3645ESEEVKIT)
		MAX3645EEEE EV kit circuit board, Rev A (MAX3645EEEEVKIT)
Z1, Z2	2	0 Ω resistors (0402)

Features

- ◆ Easy +2.97V to +5.5V Electrical Evaluation
- ◆ Fully Assembled and Tested
- ◆ Easy LOS Threshold Programming
- ◆ Designed for 50 Ω Test Interfaces
- ◆ Allows Alternate Output Terminations

Ordering Information

PART	TEMP RANGE	IC PACKAGE
MAX3645ESEEVKIT	-40°C to +85°C	16 SOIC
MAX3645EEEEVKIT	-40°C to +85°C	16 QSOP

Component Suppliers

SUPPLIER	PHONE	FAX
AVX	843-448-9411	843-626-3123
Coilcraft	847-639-6400	847-639-1469
Digi-Key	800-344-4539	218-681-3380
Murata	770-436-1300	770-436-3030

Note: Please indicate that you are using the MAX3645 when ordering from these suppliers.

Quick Start

- 1) Place a shunt on JU3 and remove shunts from JU2 and JU4.
- 2) Set the threshold resistor (R_{TH}) to 100 Ω by placing a shunt at position 4 of JU1.
- 3) Connect a +2V power supply to J3 (V_{CC}), a -1.3V power supply to J9 (V_{EE}), and the power supply ground to J4 (GND).
- 4) Apply a 155Mbps differential signal (10mV_{P-P}) between SMA connectors J1 (DIN+) and J2 (DIN-).
- 5) Connect an oscilloscope with 50 Ω terminations to SMA connectors J5 (DOUT-) and J6 (DOUT+). (To avoid overloading the oscilloscope, use 20dB of attenuation between the outputs and the oscilloscope inputs.)
- 6) Monitor LOS by connecting a voltage meter to TP9.

MAX3645 Evaluation Kit

Detailed Description

The MAX3645 EV kit is a fully assembled and factory tested demonstration board that enables testing of all MAX3645 functions.

Setting the LOS Threshold Resistor

Jumper bank JU1 is used to select the value of the threshold resistor (R_{TH}). Position 1 connects to the potentiometer R3 that can be set to any resistance value between 0Ω and $5k\Omega$. Positions 2–5 provide fixed resistance settings of $2k\Omega$, $1k\Omega$, 100Ω , 0Ω respectively.

Automatic Squelch

Placing a shunt on JU3 enables automatic squelch. This jumper connects the LOS output directly to the DIS input. If the data input signal drops below the LOS assert level the outputs are automatically disabled. When the data input signal returns above the LOS deassert level the outputs are enabled.

DC-Offset Correction

The DC offset correction is disabled when a shunt is on JU2. For normal operation, leave JU2 open.

Data Input Terminations

The EV kit has a 100Ω differential input termination. If the input is driven single-ended, terminate both sides of the input with 50Ω to ground by shorting solder bridge SB1.

PECL Output Terminations

The outputs of the MAX3645 are PECL compatible and any standard DC or AC termination can be used. Figure 1 illustrates typical DC and AC terminations.

When the data outputs are AC-coupled a shunt can be put on JU4 to short V_{EE} to ground. Otherwise JU4 should be left open.

To avoid overloading the oscilloscope, use 20dB of attenuation between the data outputs and the oscilloscope inputs.

MAX3645 Evaluation Kit

Evaluates: MAX3645

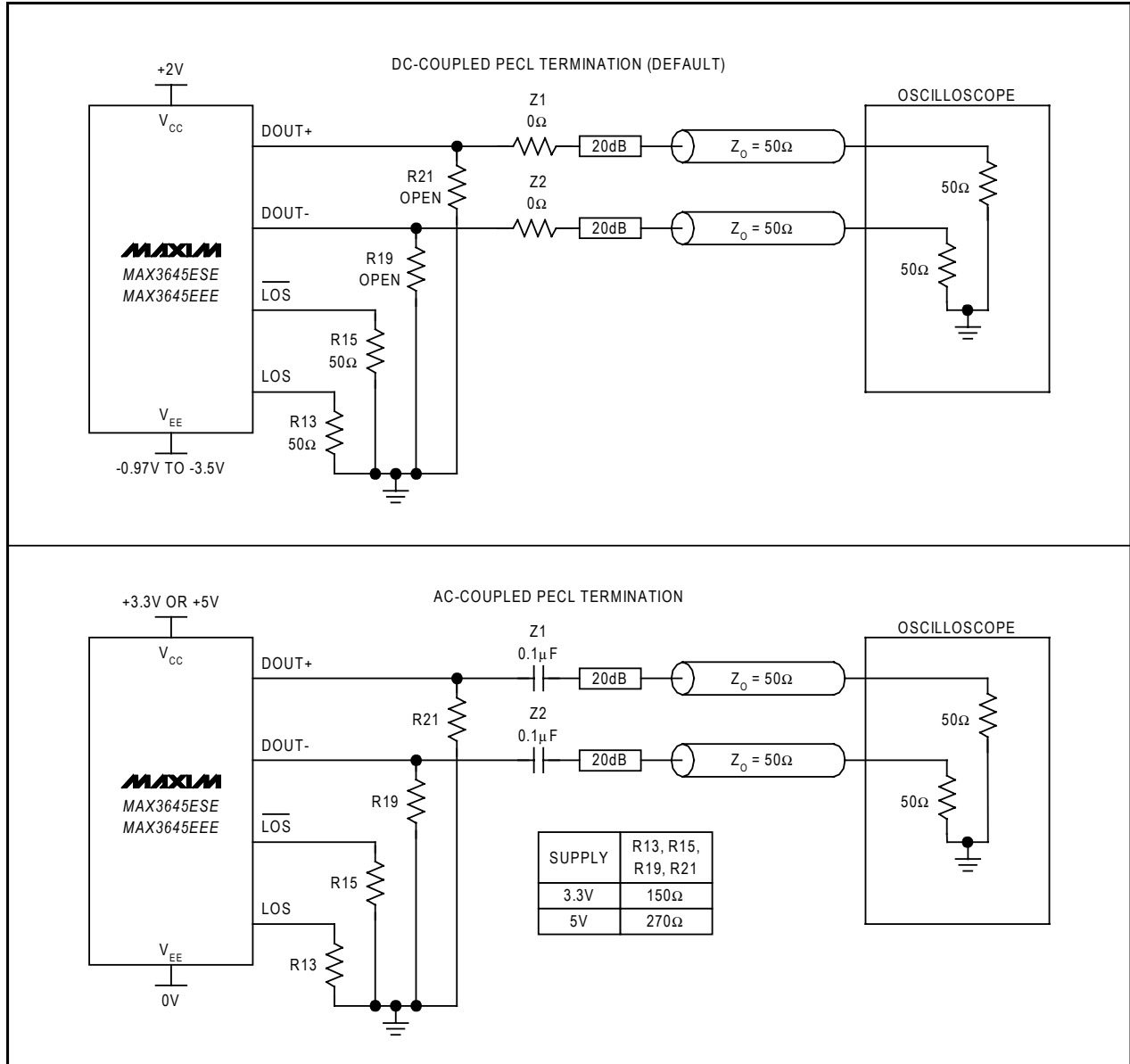

Figure 1. PECL Output Terminations

MAX3645 Evaluation Kit

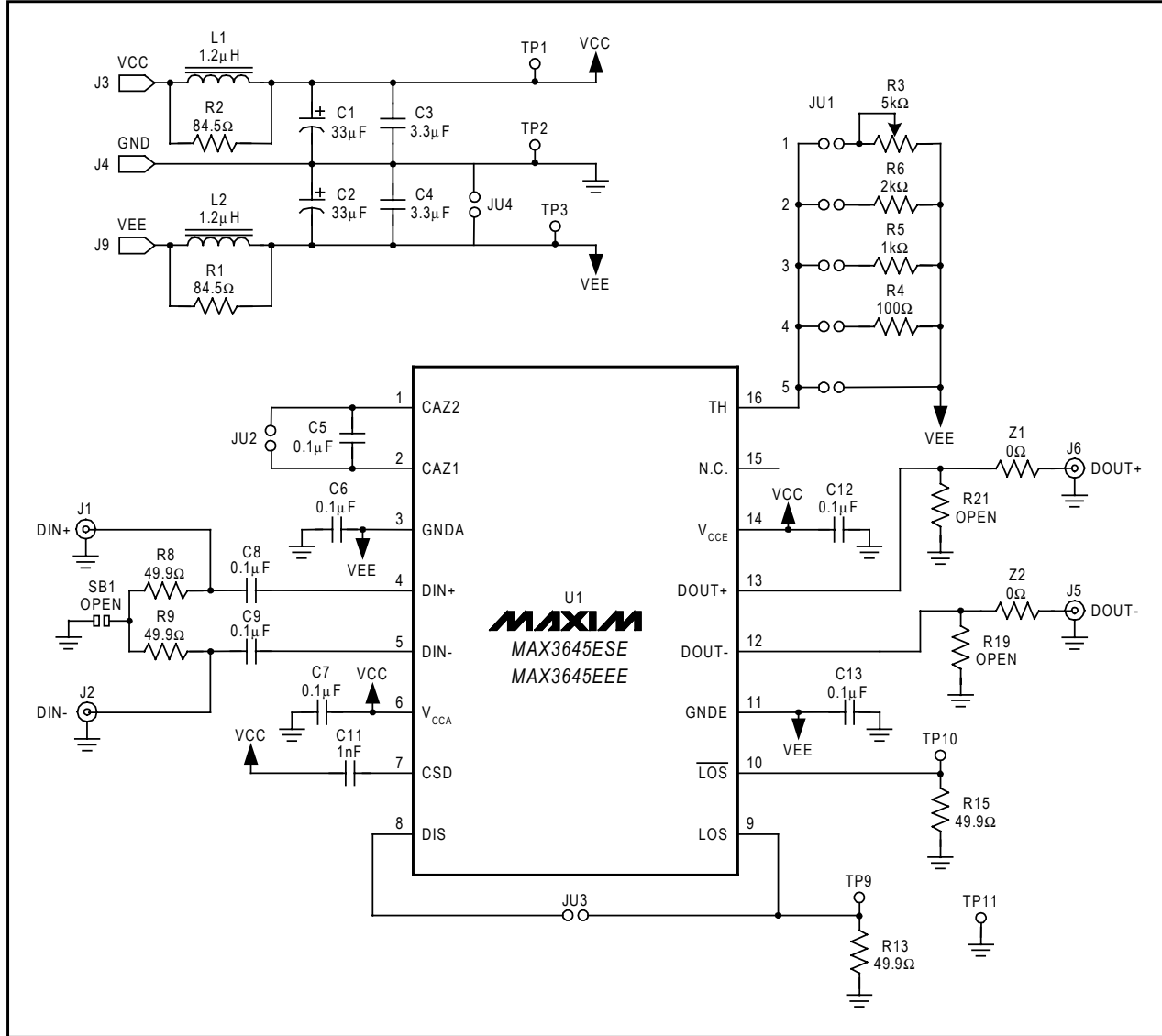

Figure 2. MAX3645 EV Kit Schematic

MAX3645 Evaluation Kit

Evaluates: MAX3645

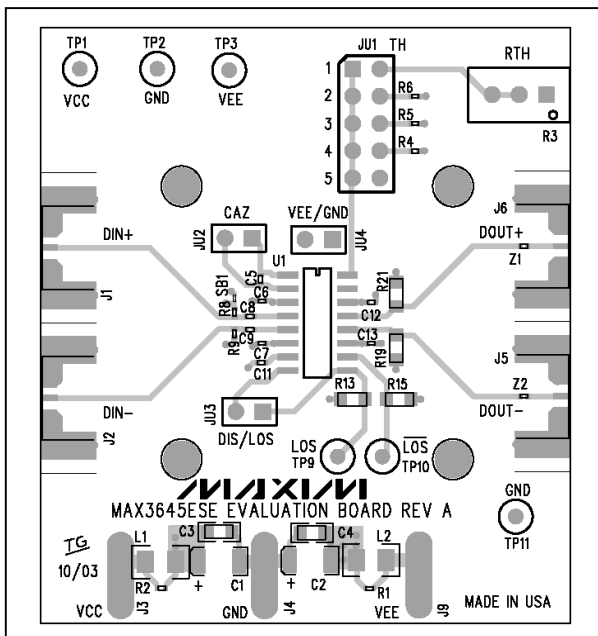

Figure 3. MAX3645ESE EV Kit Component Placement Guide—Component Side

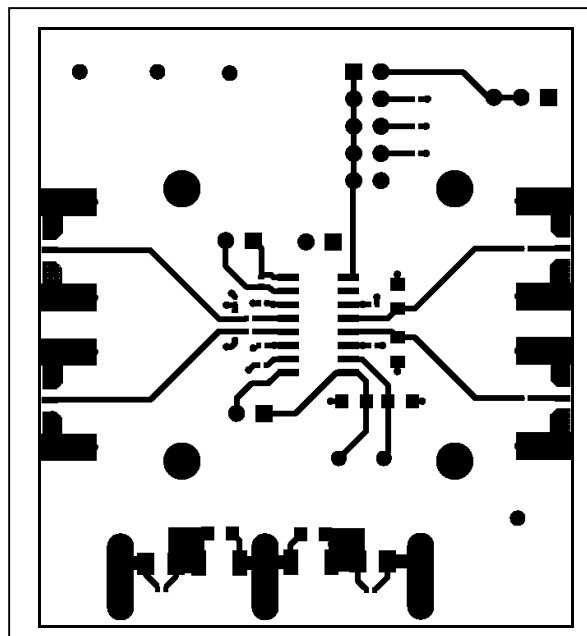

Figure 4. MAX3645ESE EV Kit PC Board Layout—Component Side

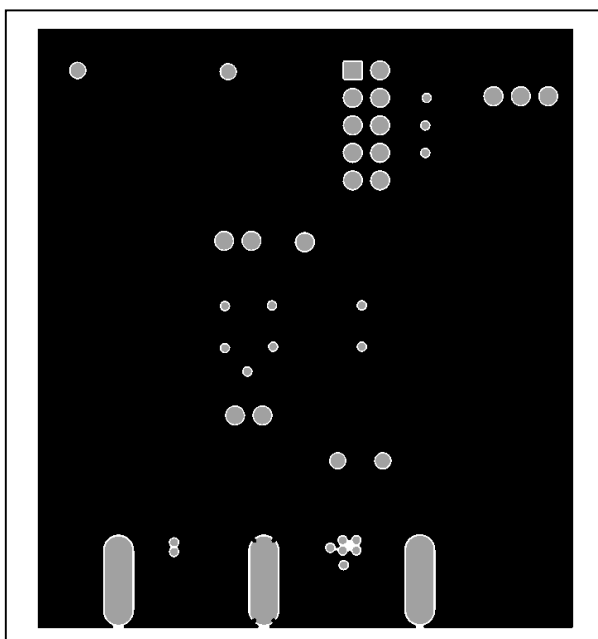

Figure 5. MAX3645ESE EV Kit PC Board Layout—Ground Plane

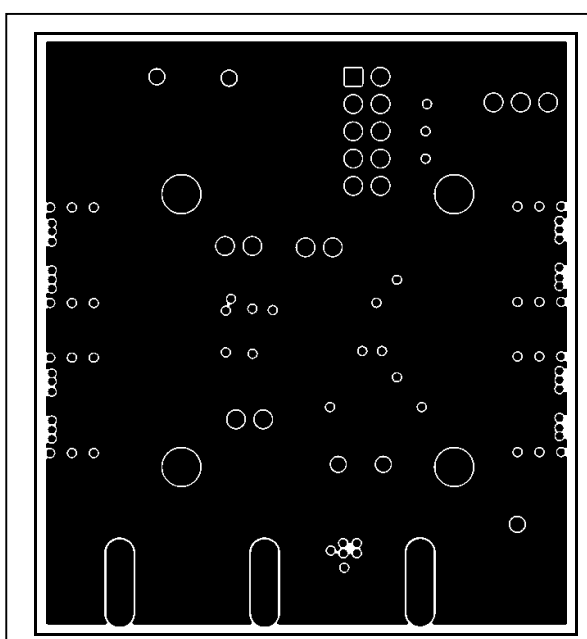

Figure 6. MAX3645ESE EV Kit PC Board Layout—Power Plane

MAX3645 Evaluation Kit

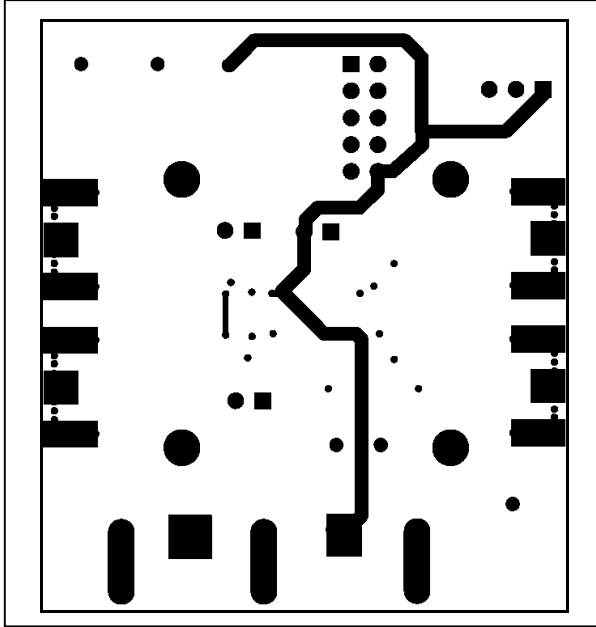

Figure 7. MAX3645ESE EV Kit PC Board Layout—Solder Side

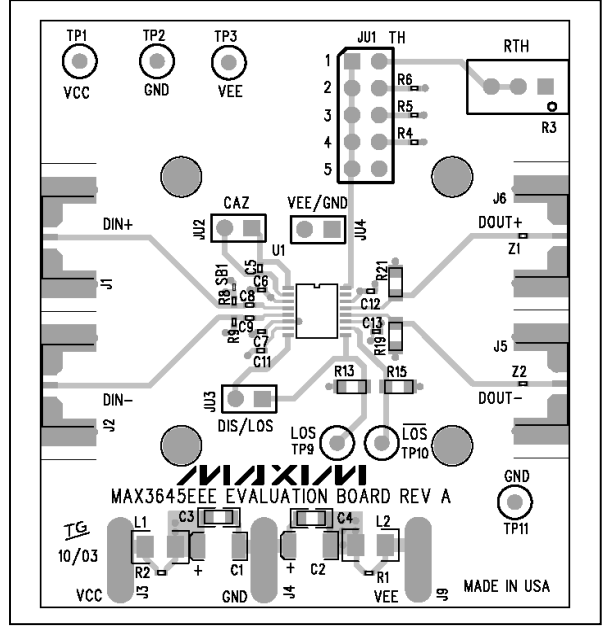

Figure 8. MAX3645EEE EV Kit Component Placement Guide—Component Side

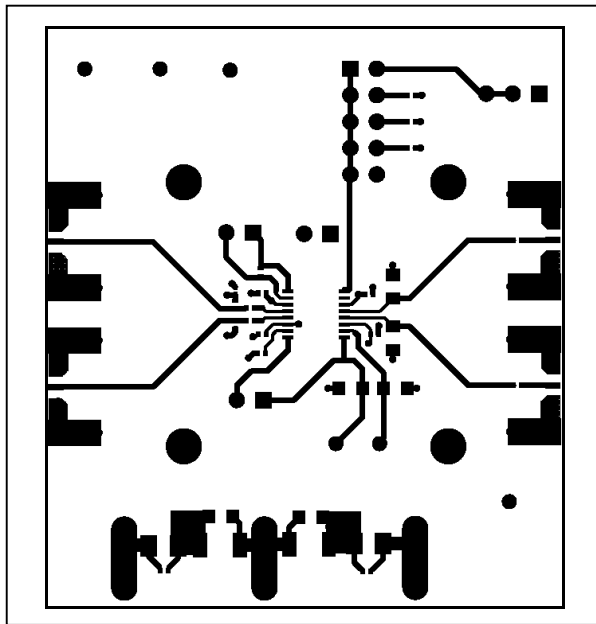

Figure 9. MAX3645EEE EV Kit PC Board Layout—Component Side

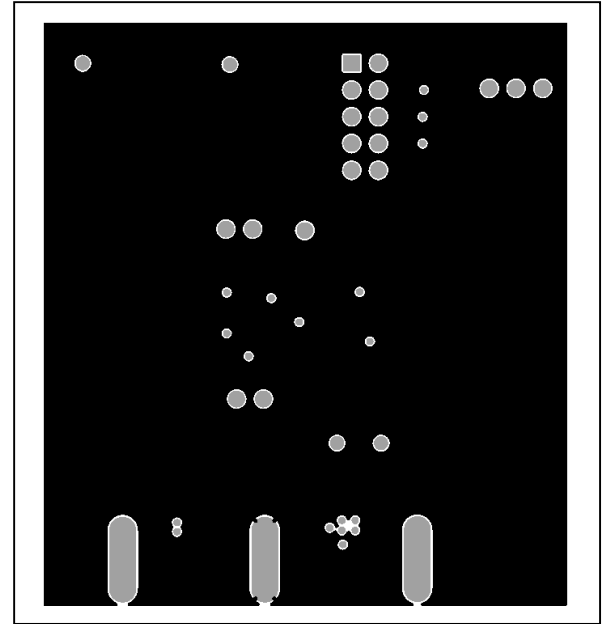

Figure 10. MAX3645EEE EV Kit PC Board Layout—Ground Plane

MAX3645 Evaluation Kit

Evaluates: MAX3645

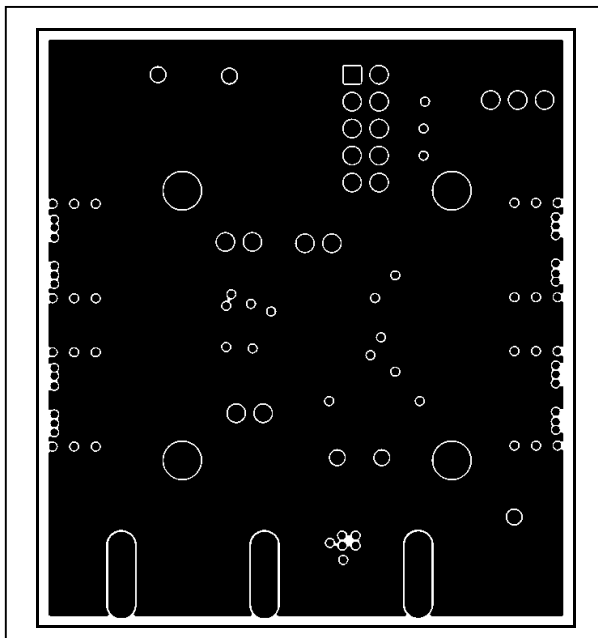

Figure 11. MAX3645EEE EV Kit PC Board Layout—Power Plane

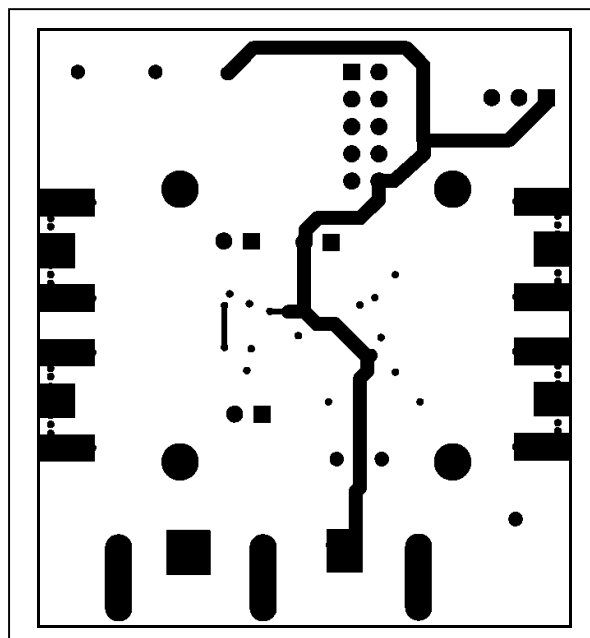

Figure 12. MAX3645EEE EV Kit PC Board Layout—Solder Side

Maxim cannot assume responsibility for use of any circuitry other than circuitry entirely embodied in a Maxim product. No circuit patent licenses are implied. Maxim reserves the right to change the circuitry and specifications without notice at any time.

Maxim Integrated Products, 120 San Gabriel Drive, Sunnyvale, CA 94086 408-737-7600 _____ 7